



Shire of Northam
Heritage, Commerce and Lifestyle

Shire of Northam

Minutes

Ordinary Council Meeting

15 March 2023



DISCLAIMER

In certain circumstances members of the public are not entitled to inspect material, which in the opinion of the Chief Executive Officer is confidential, and relates to a meeting or a part of a meeting that is likely to be closed to members of the public.

No responsibility whatsoever is implied or accepted by the Shire of Northam for any act, omission, statement or intimation occurring during Council or Committee meetings.

The Shire of Northam disclaims any liability for any loss whatsoever and howsoever caused arising out of reliance by any person or legal entity on any such act, omission or statement of intimation occurring during Council or Committee meetings.

Any person or legal entity who acts or fails to act in reliance upon any statement, act or omission made in a Council or Committee meeting does so at that person's or legal entity's own risk.

In particular and without derogating in any way from the broad disclaimer above, in any discussion regarding any planning application or application for a licence, any statement or intimation of approval made by any member or Officer of the Shire of Northam during the course of any meeting is not intended to be and is not taken as notice of approval from the Shire of Northam.

The Shire of Northam advises that anyone who has any application lodged with the Shire of Northam must obtain and should only rely on WRITTEN CONFIRMATION of the outcome of the application and any conditions attaching to the decision made by the Shire of Northam in respect of the application.

The Shire of Northam advises that any plans or documents contained within this agenda may be subject to copyright law provisions (*Copyright Act 1968*, as amended) and that the express permission of the copyright owner(s) should be sought prior to their reproduction. It should be noted that copyright owners are entitled to take legal action against any persons who infringe their copyright. A reproduction of material that is protected by copyright may represent a copyright infringement.

Contents

1	DECLARATION OF OPENING.....	5
2	ACKNOWLEDGEMENT OF COUNTRY	5
3	ATTENDANCE.....	5
3.1	ATTENDEES	5
3.2	APOLOGIES	6
3.3	APPROVED LEAVE OF ABSENCE.....	6
3.4	ABSENT.....	6
4	DISCLOSURE OF INTERESTS.....	6
5	ANNOUNCEMENTS BY THE PRESIDING MEMBER WITHOUT DISCUSSION	8
6	PUBLIC QUESTIONS.....	9
7	RESPONSE TO PREVIOUS PUBLIC QUESTIONS TAKEN ON NOTICE.....	10
8	RECEIVING OF PETITIONS, PRESENTATIONS AND DEPUTATIONS.....	10
8.1	PETITIONS	10
8.2	PRESENTATIONS	10
8.3	DEPUTATIONS	11
9	APPLICATIONS FOR LEAVE OF ABSENCE	11
10	CONFIRMATION OF MINUTES	12
10.1	CONFIRMATION OF MINUTES FROM THE ORDINARY COUNCIL MEETING HELD 15 FEBRUARY 2023.....	12
10.2	NOTES FROM THE COUNCIL FORUM MEETING HELD 08 MARCH 2023 ..	12
10.3	NOTES FROM THE STRATEGIC COUNCIL MEETING HELD 22 FEBRUARY 2023.....	38
11	ITEMS BROUGHT FORWARD FOR THE CONVENIENCE OF THOSE IN THE PUBLIC GALLERY.....	38
12	REPORTS OF COMMITTEE MEETINGS.....	38
12.1	COMMUNITY SAFETY COMMITTEE MEETING HELD ON 14 FEBRUARY 2023	38
12.2	AUDIT AND RISK MANAGEMENT COMMITTEE HELD ON 23 FEBRUARY 2023.....	61
12.3	LOCAL EMERGENCY MANAGEMENT COMMITTEE MEETING HELD ON 02 MARCH 2023	124

13 OFFICER REPORTS.....	153
13.1 CEO'S OFFICE.....	153
13.1.1 2023 Local Government Ordinary Elections	153
13.1.2 Renewal Of Lease For Uniting Church Homes (Juniper) - 63 Wellington Street, Northam.....	159
13.1.3 Request To Operate A Gyrocopter - Northam Airport	164
13.1.4 Review Of Governance Policies	175
13.2 ENGINEERING SERVICES.....	259
13.3 DEVELOPMENT SERVICES	259
13.3.1 Proposed Scheme Amendment 18 - 54 Byfield St, Northam ..	259
13.3.2 Proposed Incidental Use - 366 Horton Road, Woottating	300
13.4 CORPORATE SERVICES.....	393
13.4.1 Accounts & Statements Of Accounts - 1 February 2023 To 28 February 2023	393
13.4.2 Financial Statements For The Period 1 February 2023 To 28 February 2023	453
13.4.3 Budget Review 2022/23.....	472
13.5 COMMUNITY SERVICES	489
13.5.1 Financial Support For The 2023 National Ballooning Championships.....	489
14 MATTERS BEHIND CLOSED DOORS	495
14.1 FINANCIER'S SIDE DEED - NORTHAM COUNTRY CLUB, 15 WOOD DRIVE, NORTHAM.....	495
14.2 CHIEF EXECUTIVE OFFICER REVIEW COMMITTEE MEETING HELD ON 15 FEBRUARY 2023	496
14.3 CHIEF EXECUTIVE OFFICER REVIEW COMMITTEE MEETING HELD ON 08 MARCH 2023	497
15 MOTIONS OF WHICH PREVIOUS NOTICE HAS BEEN GIVEN	498
16 URGENT BUSINESS APPROVED BY DECISION	498
17 DECLARATION OF CLOSURE	498

1 DECLARATION OF OPENING

The Shire President, Cr C R Antonio, declared the meeting open at 5:30 pm.

2 ACKNOWLEDGEMENT OF COUNTRY

The Shire President, Cr C R Antonio, acknowledged the Traditional Owners of the land on which we meet, the Ballardong and Whadjuk people of the Nyoongar nation and paid our respects to Elders, past present and emerging.

3 ATTENDANCE

3.1 ATTENDEES

Council:

Shire President

C R Antonio

Deputy Shire President

M P Ryan

Councillors

D J Galloway

R W Tinetti

A J Mencshelyi

M I Girak

D A Hughes

H J Appleton

Staff:

Chief Executive Officer

J B Whiteaker

Acting Executive Manager Engineering Services

C B Hunt

Acting Executive Manager Development Services

J Jurmann

Executive Manager Corporate Services

C J Young

Executive Manager Community Services

J Metcalf

Governance Coordinator

A C McCall

Governance Officer

T P Van Beek

Gallery:

WA Police

M Glynn (left the meeting at 6:06pm)

Public

B Crum (left the meeting at 6:06pm)

N Willis (left the meeting at 6:06pm)

C Munson (left the meeting at 5:48pm)

S Hart
W Jones (left the meeting at
6:05pm)
K Nieuwoudt (left the meeting
at 5:51pm)

3.2 APOLOGIES

Council:

Councillor

J E G Williams

3.3 APPROVED LEAVE OF ABSENCE

Nil.

3.4 ABSENT

Nil.

4 DISCLOSURE OF INTERESTS

Members should fill in Disclosure of Interest forms for items in which they have a financial, proximity or impartiality interest and forward these to the Presiding Member before the meeting commences.

*As defined in section 5.60A of the Local Government Act 1995, a **financial interest** occurs where a Councillor / Committee Member, or a person with whom the Councillor / Committee Member is closely associated, has a direct or indirect financial interest in the matter. That is, the person stands to make a financial gain or loss from the decision, either now or at some time in the future.*

*As defined in section 5.61 of the Local Government Act 1995, an **indirect financial interest** includes a reference to a financial relationship between that person and another person who requires a Local Government decision in relation to the matter.*

*As defined in section 5.60B of the Local Government Act 1995, a person has a **proximity interest** in a matter if the matter concerns a proposed change to a planning scheme affecting land that adjoins the person's land; or a proposed change to the zoning or use of land that adjoins the person's land; or a proposed development (as defined in section 5.63(5)) of land that adjoins the person's land.*

As defined in 34C of the Local Government (Administration) Regulations 1996, an **impartiality interest** means an interest that could, or could reasonably be perceived to, adversely affect the impartiality of the person having the interest and includes an interest arising from kinship, friendship or membership of an association.

Item Name	Item No.	Name	Type of Interest	Nature of Interest
Request to operate a Gyrocopter – Northam Airport	13.1.3	R W Tinetti	Impartiality	The President and several members of the Northam Aero Club are known to Cr Tinetti.
Request to operate a Gyrocopter – Northam Airport	13.1.3	M I Girak	Impartiality	Some members of the Northam Aero Club are known to Cr Girak

5 ANNOUNCEMENTS BY THE PRESIDING MEMBER WITHOUT DISCUSSION

Visitations and Consultations	
18/02/2023	Northam Tennis Club Men's Doubles Championship Presentation
19/02/2023	Northam Vintage Swap Meet
20/02/2023	Triple M Weekly Radio Interview
23/02/2023	Official Opening of the LiveLighter Aged Care Games - Northam
24/02/2023	Regional Capital Alliance WA Meeting - Online
02/03/2023	Local Emergency Management Committee Meeting - Northam
04/03/2023	WA Country Swimming Pennants - Northam
04/03/2023	Lions Community Markets - Northam
05/03/2023	WA Country Swimming Pennants Closing Ceremony
06/03/2023	Labour Day Holiday
07/03/2023	Triple M Weekly Radio Interview
07/03/2023	Northam Chamber of Commerce and Shire of Northam Meeting
08/03/2023	Northam Women in Business Breakfast guest speaker
08/03/2023	RDA Wheatbelt Committee Presentation
08/03/2023	Wheatbelt Regional Planning Workshop - Northam
13/03/2023	AROC Governance Meeting - Toodyay
14/03/2023	Triple M Weekly Radio Interview
Upcoming Events	
16/03/2023	Shire of Northam Extraordinary Election
17/03/2023	Freshstart Northam Invitation – Farewell and Meeting staff
21/03/2023	Triple M Weekly Radio Interview
23/03/2023	Avon Industrial Park Advisory Board Meeting
28/03/2023	Triple M Weekly Radio Interview
29/03/2023	General Meeting of the District Emergency Management Committee
30/03/2023	Staying in Place Expo - Pingelly
01/04/2023	Lions Community Markets - Northam
02/04/2023	Northam Motorsport Festival Official Morning Tea
02/04/2023	Long Table Lunch – Spencers Brook
04/04/2023	Triple M Weekly Radio Interview
09/04/2023	Easter Sunday
11/04/2023	Triple M Weekly Radio Interview

Operational Matters:

A Local Government extraordinary election will be held on Thursday, the 16th of March 2023 to fill a vacancy in the West Ward for 1 Councillor. Following the close of nominations, electors in the Shire of Northam West Ward local

government electoral roll were sent election packages. Replacement Packages are available from the Shire of Northam, and all completed voting packages must reach the Returning Officer by 6:00 pm on the election day, being Thursday, the 16th of March 2023.

Following advice and consideration, the Shire of Northam remains in a Prohibited Burning Period until the 12th of March 2023 (may be subject to change).

Events Calendar:

The WA Country Swimming Pennants was held over the March Long weekend, 4th and 5th of March. With over 1000 competitors, and an estimated 5000 visitors to the Shire, the event was a great success. Well done to all the organisers, volunteers, competitors, and everyone involved with this event. Country Pennants is the highlight of the regional swimming calendar, with the first event being hosted by Northam back in 1959.

Apart from many local and community events, the next major event is the Northam Motorsport Festival for 2023. Held over the 1st weekend in April, this event, being the 7th anniversary since inception, highlights many of the great offerings our Shire has to show.

Strategic Matters:

Following the launch of our Community Plan in 2022, the Shire continues to communicate to residents and ratepayers what has been asked for. Recent advices published for the public include the Shire of Northam Dashboard and the Complaints report.

6 PUBLIC QUESTIONS

Name:

Martin Glynn - Senior Sergeant, WA Police

Summary of Question 1:

In regard to the CCTV and the Community Safety Committees Crime Prevention Committee, the WA Police would like to maximise the benefit from the Shire's investment and continue to collaborate in particular as it relates to potential Automatic Number Plate Reader (ANPR) system. When will the Shire be reviewing improvements in this program and what will the budget put in be?

Summary of Response 1:

A review is in the process of being finalized and will be presented to the Community Safety & Crime Prevention Committee in the coming months. The WA Police have been consulted and provided input in the current review. At this point there is no specific budget allocated to this item, however there are plans to secure external funding. While this is the case, once the plan is endorsed by Council a financial commitment may be made.

Summary of Question 2:

Could the Councillors share what they feel are the priorities of the Community Safety Committee and where does the Shire see the future endeavors going? i.e. What does the Council see the Community wanting?

Summary of Response 2:

Council priorities are guided by the Community Safety & Crime Prevention Committee. At next committee meeting the focus will be on identifying gaps in the service for youth agencies / groups in the community. The Council have recently adopted the community safety plan in 2022 and that was with the consultation of the community

and outlines Council views on priorities and future plans.

7 RESPONSE TO PREVIOUS PUBLIC QUESTIONS TAKEN ON NOTICE

Nil.

8 RECEIVING OF PETITIONS, PRESENTATIONS AND DEPUTATIONS

8.1 PETITIONS

Nil.

8.2 PRESENTATIONS

Nil.

8.3 DEPUTATIONS

Name:	Corey Munson
Item Name:	13.1.3 - Request to Operate a Gyrocopter - Northam Airport
Summary of Deputation:	<p>Deputation raised comments around:</p> <ul style="list-style-type: none">• Deputation and comments raised against the agenda item during the Council Forum Meeting (08 March 2023)• Previous training and experience of the Pilot, including training with the Northam Aeroclub in light planes.• Clarification that concerns raised about Gyrocopter safety can be corrected by being a good pilot.• Further information on the specific model of Gyrocopter in the request.• Confirmation that Gyrocopters do not technically request a developed airstrip to operate, however not using a developed

strip can result in damage to the aircraft and is costly to fix.

9 APPLICATIONS FOR LEAVE OF ABSENCE

RECOMMENDATION / COUNCIL DECISION

Minute No: C.4676

Moved: Cr D J Galloway

Seconded: Cr M P Ryan

That Council grant Cr A J Mencshelyi leave of absence from 03 April 2023 to 28 April 2023 (inclusive).

CARRIED 8/0

RECOMMENDATION / COUNCIL DECISION

Minute No: C.4677

Moved: Cr A J Mencshelyi

Seconded: Cr M P Ryan

That Council grant Cr H J Appleton leave of absence from 04 April 2023 to 18 April 2023 (inclusive).

CARRIED 8/0

10 CONFIRMATION OF MINUTES

**10.1 CONFIRMATION OF MINUTES FROM THE ORDINARY COUNCIL MEETING
HELD 15 FEBRUARY 2023**

RECOMMENDATION / COUNCIL DECISION

Minute No: C.4678

Moved: Cr D A Hughes

Seconded: Cr A J Mencshelyi

That the minutes of the Ordinary Council meeting held on Wednesday, 15 February 2023 be confirmed as a true and correct record of that meeting.

CARRIED 8/0

10.2 NOTES FROM THE COUNCIL FORUM MEETING HELD 08 MARCH 2023

RECOMMENDATION / COUNCIL DECISION

Minute No: C.4679

Moved: Cr H J Appleton

Seconded: Cr M I Girak

That Council receive the notes from the Council Forum Meeting held on Wednesday, 08 March 2023.

CARRIED 8/0



Shire of Northam
Heritage, Commerce and Lifestyle

Shire of Northam

Notes

Council Forum Meeting

08 March 2023

Council Forum Meeting Notes
08 March 2023



DISCLAIMER

In certain circumstances members of the public are not entitled to inspect material, which in the opinion of the Chief Executive Officer is confidential, and relates to a meeting or a part of a meeting that is likely to be closed to members of the public.

No responsibility whatsoever is implied or accepted by the Shire of Northam for any act, omission, statement or intimation occurring during Council or Committee meetings.

The Shire of Northam disclaims any liability for any loss whatsoever and howsoever caused arising out of reliance by any person or legal entity on any such act, omission or statement of intimation occurring during Council or Committee meetings.

Any person or legal entity who acts or fails to act in reliance upon any statement, act or omission made in a Council or Committee meeting does so at that person's or legal entity's own risk.

In particular and without derogating in any way from the broad disclaimer above, in any discussion regarding any planning application or application for a licence, any statement or intimation of approval made by any member or Officer of the Shire of Northam during the course of any meeting is not intended to be and is not taken as notice of approval from the Shire of Northam.

The Shire of Northam advises that anyone who has any application lodged with the Shire of Northam must obtain and should only rely on WRITTEN CONFIRMATION of the outcome of the application and any conditions attaching to the decision made by the Shire of Northam in respect of the application.

The Shire of Northam advises that any plans or documents contained within this agenda may be subject to copyright law provisions (*Copyright Act 1968*, as amended) and that the express permission of the copyright owner(s) should be sought prior to their reproduction. It should be noted that copyright owners are entitled to take legal action against any persons who infringe their copyright. A reproduction of material that is protected by copyright may represent a copyright infringement.

**Council Forum Meeting Notes
08 March 2023**



Preface

When the Chief Executive Officer approves these Notes for distribution they are in essence "informal notes."

At the next Ordinary Meeting of Council the Notes will be received, subject to any amendments made by the Council. The "Received" Notes are then signed off by the Presiding Person.

Please refer to the Ordinary Council meeting agenda and minutes for further information and details in relation to the matters and items discussed at the Forum meeting.

Unconfirmed Notes

These notes were approved for distribution on 10 March 2023.

A handwritten signature in black ink, appearing to read "J Whiteaker".

**JASON WHITEAKER
CHIEF EXECUTIVE OFFICER**

Received Notes

These notes were received at an Ordinary Meeting of Council held on 15 March 2023.

Signed:
A handwritten signature in blue ink, appearing to be a cursive name.

Note: The Presiding Member at the meeting at which the minutes were confirmed is the person who signs above.



Contents

1	DECLARATION OF OPENING	6
2	ACKNOWLEDGEMENT OF COUNTRY	6
3	ATTENDANCE	6
3.1	ATTENDEES	6
3.2	APOLOGIES	6
3.3	APPROVED LEAVE OF ABSENCE	6
3.4	ABSENT	7
4	DISCLOSURE OF INTERESTS	7
5	ANNOUNCEMENTS BY THE PRESIDING MEMBER WITHOUT DISCUSSION.....	8
6	PUBLIC QUESTIONS	8
7	RESPONSE TO PREVIOUS PUBLIC QUESTIONS TAKEN ON NOTICE	8
8	RECEIVING OF PETITIONS, PRESENTATIONS AND DEPUTATIONS.....	8
8.1	PETITIONS	8
8.2	PRESENTATIONS	8
8.3	DEPUTATIONS.....	8
9	APPLICATIONS FOR LEAVE OF ABSENCE.....	10
10	CONFIRMATION OF MINUTES.....	10
10.1	CONFIRMATION OF MINUTES FROM THE ORDINARY COUNCIL MEETING HELD 15 FEBRUARY 2023	10
10.2	NOTES FROM THE COUNCIL FORUM MEETING HELD 08 MARCH 2023 .	10
10.3	NOTES FROM THE STRATEGIC COUNCIL MEETING HELD 22 FEBRUARY 2023.....	10
11	ITEMS BROUGHT FORWARD FOR THE CONVENIENCE OF THOSE IN THE PUBLIC GALLERY	11
13.1.3	Request to operate a Gyrocopter - Northam Airport.....	11
13.3.1	Proposed Scheme Amendment 18 – 54 Byfield St, Northam ...	13
12	REPORTS OF COMMITTEE MEETINGS	15
12.1	COMMUNITY SAFETY COMMITTEE MEETING HELD ON 14 FEBRUARY 2023	15
12.2	AUDIT AND RISK MANAGEMENT COMMITTEE HELD ON 23 FEBRUARY 2023.....	15

Council Forum Meeting Notes
08 March 2023



12.3 LOCAL EMERGENCY MANAGEMENT COMMITTEE MEETING HELD ON 02 MARCH 2023	16
13 OFFICER REPORTS	16
13.1 CEO'S OFFICE	16
13.1.1 2023 Local Government Ordinary Elections	16
13.1.2 Renewal of Lease for Uniting Church Homes (Juniper) - 63 Wellington Street, Northam	16
13.1.4 Review of Governance Policies	17
13.2 ENGINEERING SERVICES	17
13.3 DEVELOPMENT SERVICES.....	17
13.3.2 Proposed Incidental Use - 366 Horton Road, Woottating.....	17
13.4 CORPORATE SERVICES	18
13.4.1 Accounts & Statements of Accounts - 1 February 2023 to 28 February 2023.....	18
13.4.2 Financial Statements for the period 1 February 2023 to 28 February 2023.....	20
13.4.3 Budget Review 2022/23	20
13.5 COMMUNITY SERVICES	21
13.5.1 Financial support for the 2023 National Ballooning Championships	21
14 MATTERS BEHIND CLOSED DOORS	23
14.1 FINANCIER'S SIDE DEED - NORTHAM COUNTRY CLUB, 15 WOOD DRIVE, NORTHAM	23
14.2 CHIEF EXECUTIVE OFFICER REVIEW COMMITTEE MEETING HELD ON 15 FEBRUARY 2023.....	23
15 MOTIONS OF WHICH PREVIOUS NOTICE HAS BEEN GIVEN	24
16 URGENT BUSINESS APPROVED BY DECISION	24
17 DECLARATION OF CLOSURE.....	24

Council Forum Meeting Notes
08 March 2023



1 DECLARATION OF OPENING

The Shire President, Cr C R Antonio, declared the meeting open at 5:30pm.

2 ACKNOWLEDGEMENT OF COUNTRY

The Shire of Northam would like to acknowledge the Traditional Owners of the land on which we meet, the Ballardong and Whadjuk people of the Nyoongar nation and pay our respects to Elders, past present and emerging.

3 ATTENDANCE

3.1 ATTENDEES

Council:

Shire President
Deputy Shire President
Councillors

C R Antonio
M P Ryan
D J Galloway
R W Tinetti
A J Mencshelyi
M I Girak
J E G Williams
D A Hughes
H J Appleton

Staff:

Chief Executive Officer
Acting Executive Manager Engineering Services
Acting Executive Manager Development Services
Executive Manager Corporate Services
Executive Manager Community Services
Governance Coordinator
Governance Officer

J B Whiteaker
C B Hunt
J Jurmann
C J Young
J Metcalf
A C McCall
T P Van Beek

Gallery:

Public

D Beresford (left the meeting at 6:01pm.)
W Jones (left the meeting at 6:16pm)
R Moller (left the meeting at 6:16pm)

3.2 APOLOGIES

Nil.

3.3 APPROVED LEAVE OF ABSENCE

Nil.



Council Forum Meeting Notes
08 March 2023

3.4 ABSENT

Nil.

4 DISCLOSURE OF INTERESTS

Members should fill in Disclosure of Interest forms for items in which they have a financial, proximity or impartiality interest and forward these to the Presiding Member before the meeting commences.

As defined in section 5.60A of the Local Government Act 1995, a **financial interest** occurs where a Councillor / Committee Member, or a person with whom the Councillor / Committee Member is closely associated, has a direct or indirect financial interest in the matter. That is, the person stands to make a financial gain or loss from the decision, either now or at some time in the future.

As defined in section 5.61 of the Local Government Act 1995, an **indirect financial interest** includes a reference to a financial relationship between that person and another person who requires a Local Government decision in relation to the matter.

As defined in section 5.60B of the Local Government Act 1995, a person has a **proximity interest** in a matter if the matter concerns a proposed change to a planning scheme affecting land that adjoins the person's land; or a proposed change to the zoning or use of land that adjoins the person's land; or a proposed development (as defined in section 5.63(5)) of land that adjoins the person's land.

As defined in 34C of the Local Government (Administration) Regulations 1996, an **impartiality interest** means an interest that could, or could reasonably be perceived to, adversely affect the impartiality of the person having the interest and includes an interest arising from kinship, friendship or membership of an association.

Item Name	Item No.	Name	Type of Interest	Nature of Interest
Request to operate a Gyrocopter – Northam Airport	13.1.3	J E G Williams	Impartiality	Cr Williams' sister & brother-in-law are hangar owners at Northam Airport.
		R W Tinetti	Impartiality	The President and several members of the Northam Aero Club are known to Cr Tinetti.
		M I Girak	Impartiality	Some members of the Northam Aero Club are known to Cr Girak.

Council Forum Meeting Notes
08 March 2023



5 ANNOUNCEMENTS BY THE PRESIDING MEMBER WITHOUT DISCUSSION

Nil.

6 PUBLIC QUESTIONS

Nil.

7 RESPONSE TO PREVIOUS PUBLIC QUESTIONS TAKEN ON NOTICE

Nil.

8 RECEIVING OF PETITIONS, PRESENTATIONS AND DEPUTATIONS

8.1 PETITIONS

Nil.

8.2 PRESENTATIONS

Nil.

8.3 DEPUTATIONS

Name: Denis Beresford.

Agenda Item: 13.1.3 Request to operate a Gyrocopter – Northam Airport.

Summary of Deputation: Raised issues around:

- Previous experience with Gyrocopters operating at Northam Airport.
- Potential for collision between gyrocopters and other aircraft during landing due to not knowing where they are located in the circuit.
- Differences in speed between gyrocopters and light planes.
- Northam Airport being treated as a hub for Gyrocopters on weekends.
- The future of the Airport and how Council should be viewing this as an alternative to Jandakot Airport.
- Alternative options for gyrocopter operators detailing that they do not need a developed airstrip to operate.

(Images below provided as examples of current planes using the Northam Airport, including a crop duster being overhauled at a commercial business based at the Northam Airport).

Council Forum Meeting Notes
08 March 2023

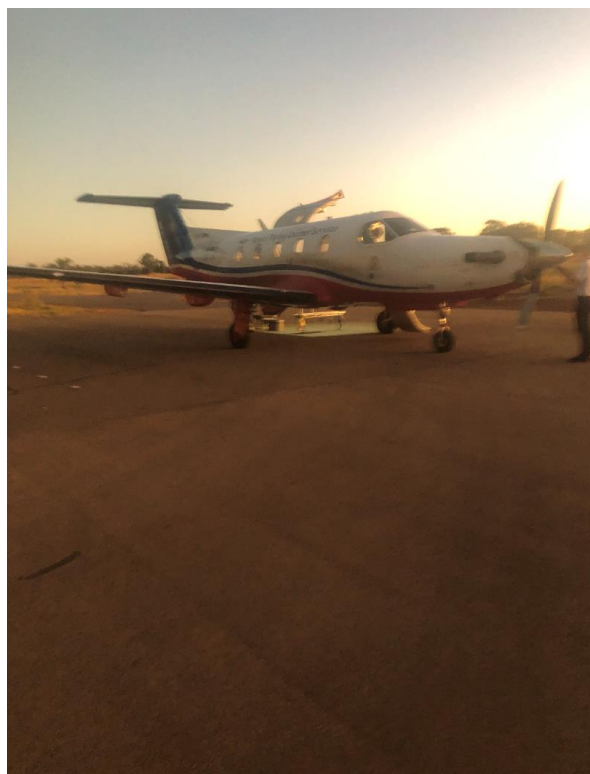



Council Forum Meeting Notes
08 March 2023

Name:	Warren Jones.
Agenda Item:	13.3.1 – Proposed Scheme Amendment 18 – 54 Byford Street, Northam.
Summary of Deputation:	<p>Raised issues around:</p> <ul style="list-style-type: none"> • Developer removing boundary fencing without consultation. • Developer pushing piles of dirt up to boundary causing a fire hazard. • Concerns relating to potential for flooding in the area, especially with new development. • Lack of response from Shire of Northam regarding inquiries and complaints made regarding the development. • Lack of information on plans for small creek/gully running through their property. • Concerns regarding an open drain. <p>Requested the following outcomes:</p> <ul style="list-style-type: none"> • Timeline relating to sub-division development and related works (including open drain) • Response from Shire staff regarding plans for the small creek/gully. • Assistance from Shire staff to rectify removed boundary fence and dirt piles.

9 APPLICATIONS FOR LEAVE OF ABSENCE

Nil.

10 CONFIRMATION OF MINUTES

10.1 CONFIRMATION OF MINUTES FROM THE ORDINARY COUNCIL MEETING HELD 15 FEBRUARY 2023

Nil.

10.2 NOTES FROM THE COUNCIL FORUM MEETING HELD 08 MARCH 2023

Not applicable.

10.3 NOTES FROM THE STRATEGIC COUNCIL MEETING HELD 22 FEBRUARY 2023

Clarification was sought in relation to:

- Statistics on the number of children who will use the bus shelter and if this will be taken into consideration or lead to a change?

The Chief Executive Officer clarified that the note document is

Council Forum Meeting Notes
08 March 2023



accurate in terms of the outcome, and this is an additional query. Staff will identify the statistics and advise at a later date.

11 ITEMS BROUGHT FORWARD FOR THE CONVENIENCE OF THOSE IN THE PUBLIC GALLERY

The Shire President, Cr C R Antonio declared that the following items be brought forward for the convenience of the Public Gallery.

Cr J E G Williams declared an "Impartiality" interest in item 13.1.3 – Request to operate a Gyrocopter – Northam Airport, as Cr Williams' sister and brother-in-law are hangar owners at the Northam Airport.

Cr R W Tinetti declared an "Impartiality" interest in item 13.1.3 – Request to operate a Gyrocopter – Northam Airport, as the President and several members of the Northam Aero Club are known to Cr Tinetti.

Cr M I Girak declared an "Impartiality" interest in item 13.1.3 – Request to operate a Gyrocopter – Northam Airport, as some members of the Aero Club are known to Cr Girak.

13.1.3 Request to operate a Gyrocopter - Northam Airport

Clarification was sought in relation to:

- Does Jandakot Airport allow Gyrocopters?

The Governance Coordinator advised that they do not.

- As the applicant has indicated that the engine used is similar to other light planes, will the engine produce a similar amount of noise?

The Governance Coordinator advised that the applicant has noted that their Gyrocopter is a newer model and would be comparable to other aircrafts. The Chief Executive Officer clarified that we are not trying to mimic the Jandakot airport but are providing an alternative. It was noted that it is the larger airports who tend to have a restriction on gyrocopters.

- Has the recommendation taken into consideration that the planes may not be able to see each other?

The Governance Coordinator advised that this has been considered and triggered the recommendation around mandating the use and carriage of radios to communicate location and descent.

Council Forum Meeting Notes
08 March 2023



- Would the enforcement of use of radios come after becoming certified?

The Governance Coordinator advised that we do not need to be certified in order to enforce the radios as we are within our rights to make it a requirement. We have contacted CASA about pricing to become certified and they have advised that they will not advise pricing until an application is made. The Aero Club (Airport Managers) have indicated that there is no interest at this time with respect to becoming certified.

- Are the current users happy to comply with the requirement to carry radios?

The Governance Coordinator advised that we have not consulted with the current hangar owners, but in correspondence with the Aero Club, who manage the airport, we have been advised that most users will already have radios and therefore the impact is expected to be minimal.

- Have staff contacted the Kalgoorlie-Boulder Airport as a comparison?

The Governance Coordinator advised that we have not spoken to Kalgoorlie-Boulder, the airports that were contacted are listed in the report.

- In regard to the circuit around the airport, does this not go over residential properties?

The Governance Coordinator advised that CASA are the ones who enforce the Standards, however a circuit refers to the landing pattern. (Denis Beresford, from the Northam Aero Club, was invited to provide clarification on a circuit).

- Is there any kind of priority order for planes?

Shire staff were not able to confirm. (Denis Beresford was invited to respond, advising that priority is given to the Royal Flying Doctors, then emergency services, then commercial, then private aircrafts. However, if anyone declares an emergency, they get the priority).

- Permission to fly over residential properties.

The Governance Coordinator clarified this clause was included to address historic issues in relation to this.

Council Forum Meeting Notes
08 March 2023



- Do the larger airports have one airstrip or multiple?

Governance Coordinator advised that most are a single airstrip. The Chief Executive Officer confirmed that Bunbury Airport have one airstrip.

- Will other gyrocopters be able to use the airport?

The Governance Coordinator advised that they need to seek permission. Even if they fly up from Perth, permission would have to be sought which would follow the same process as this application.

- If Council grant permission to one gyrocopter, how can it refuse others?

The Governance Coordinator advised that each application would be assessed on its merits. Officers have recommended that they commit to building a hangar at the airport, others may not be willing to commit to this process.

- Where other hangar owners consulted regarding this?

The Governance Coordinator advised that they were not.

Member of the Public Gallery, Mr D Beresford, left the meeting at 6:01pm.

13.3.1 Proposed Scheme Amendment 18 – 54 Byfield St, Northam

Clarification was sought in relation to:

- Given the flooding issues that have occurred with other subdivisions in the Bakers Hill area, is there any way that during planning we can look at the levels to determine requirements.

The Acting Executive Manager Development Services advised that there are historic drainage issues. It was advised that detailed design and modelling would be required at the next stage of the process which would be assessed by Shire Officers.

- Clarification was provided for the location of the removed fence.
- How much of the sub-division has already been approved?

Acting Executive Manager Development Services advised that the 2 lots on Frankish Road have been approved.

- Is the proposal standard sized blocks for this area?

Council Forum Meeting Notes
08 March 2023



The Acting Executive Manager Development Services advised that the average is 450 square meters. The current coding is 580-666 square meters so the proposal will reduce the lot size by about 100 – 150 square metres.

- What is the zoning on the other side of East Street?

The Acting Executive Manager Development Services advised that it is R30.

- Clarification was provided on the drain/gully.
- What sort of mitigation would be expected?

The Acting Executive Manager Development Services advised that this detail would be determined in the next stage where detailed plans and modelling would be required. It must be demonstrated that the proposal would not worsen the situation. It has been proposed to maintain the open gully.

- Is the situation with flooding worse since the car park has been sealed?

The Acting Executive Manager Development Services cannot say, there are a lot of known hard surfaces in the area.

- Is there any way to have the area surveyed by Water Corporation to confirm that it won't worsen the flooding based on what they are building?

The Acting Executive Manager Engineering Services advised that drainage is a Shire issue, not Water Corporation. We have been looking at facilities up stream to mitigate, however it is not an easy process. Part of the approval process is that they have to prove that they won't make it worse.

- Is there funding to get drainage in that area of town?

Acting Executive Manager Engineering Services advised that there is budget to undertake a drainage assessment in this area. This may provide information on potential improvements to the network.

- Do developers have to put drainage in?

The Acting Executive Manager Development Services advised

Council Forum Meeting Notes
08 March 2023



that this is correct. It will be assessed to ensure that it is managed appropriately.

- Can council mandate that water tanks must be used of these properties?

The Acting Executive Manager Development Services advised they can. The Shire currently require water tanks be used to slow down the water flow.

- Are there requirements for water tanks?

The Acting Executive Manager Development Services advised that there are size specifications and requirements.

- Are they required to put a drainage plan in place for the entire subdivision?

Acting Executive Manager Development Services advised they need to provide this for the entire subdivision.

- Would they be able to maintain the open drain on those blocks and still build?

The Acting Executive Manager Development Services advised that the lot sizes relating to the open drain has already been assessed and approved.

- Regarding NBN in the area, will this be an issue?

The Acting Executive Manager Development Services advised there is no issue, it was just included as an awareness.

Acting Executive Manager Engineering Services and two members of the public gallery, Mr Warren Jones and Ms Rosalie Moller left the meeting at 6:16pm.

12 REPORTS OF COMMITTEE MEETINGS

12.1 COMMUNITY SAFETY COMMITTEE MEETING HELD ON 14 FEBRUARY 2023

Nil

12.2 AUDIT AND RISK MANAGEMENT COMMITTEE HELD ON 23 FEBRUARY 2023

Nil.

Council Forum Meeting Notes
08 March 2023



12.3 LOCAL EMERGENCY MANAGEMENT COMMITTEE MEETING HELD ON 02 MARCH 2023

Minor spelling and grammar adjustments identified, and changes were requested.

13 OFFICER REPORTS

13.1 CEO'S OFFICE

13.1.1 2023 Local Government Ordinary Elections

Clarification was sought in relation to:

- As the Local Government Advisory Board cannot provide a response regarding the ward review does that mean it will stay as is?

The Governance Coordinator advised that the information will be provided to us prior to the 2023 election.

- Did they also provide a quote for 3 vacancies?

The Governance Coordinator advised that they did not as once they accept the ward review there will be a total of 4 vacancies.

Acting Executive Manager Engineering Services returned to the meeting at 6:21pm.

13.1.2 Renewal of Lease for Uniting Church Homes (Juniper) - 63 Wellington Street, Northam

Clarification was sought in relation to:

- Does the Shire own the building in question?

The Governance Coordinator confirmed this is correct.

- As the Delegated Authority was not originally met, will this effect the audit?

The Chief Executive Officer advised that the comment in the report was identifying that the matter was unable to be addressed through delegated authority and hence the item was presented to Council for determination, rather than indicating there was any non-compliance.

Council Forum Meeting Notes
08 March 2023



13.1.4 Review of Governance Policies

It was raised that the report referenced adjustment being made to the Council Members – Continuing Professional Development and Elected Member Leave of Absents policies. These were taken on notice.

Additional Comment

- The following paragraph has been included in the Council Members – Continuing Professional Development policy:

In accordance with Section 5.90A of the Local Government Act 1995, the definition of an event includes conferences. Council policy G 1.2 Attendance at Events – Council Members and the Chief Executive Officer governs attendance at conferences which may contribute to the professional development of an Elected Member.

- The following paragraph has been included in the Council Members Leave of Absence policy:

6. Where the Council Member does not have leave approved in advance for a Council or Committee meeting, the member is to be recorded as an apology for that meeting.

13.2 ENGINEERING SERVICES

Nil.

13.3 DEVELOPMENT SERVICES

13.3.2 Proposed Incidental Use - 366 Horton Road, Wooffating

Clarification was sought in relation to:

- Who polices if it is non-compliant?

The Acting Executive Manager Development Services advised that it would be the Shire's Compliance Officer.

- How big are each of the blocks?

The Acting Executive Manager Development Services advised that they are about 350mm X 350mm X 1m.

- The report states that the blocks will replace the majority of loose and screened gravel, are the proposed blocks incidental to the gravel?

Council Forum Meeting Notes
08 March 2023



The Acting Executive Manager Development Services advised that this is a product from the extractive industry, making it an incidental use.

- Clarification was provided regarding access via Great Eastern Highway.
- In terms of incidental use, when does it stop being incidental?

The Acting Executive Manager Development Services advised that it stops being incidental when the block making becomes the main use and they have to import gravel on site for that purpose.

- Are they allowed to import anything currently?

The Acting Executive Manager Development Services advised they are allowed to import clean fill currently as part of their rehabilitation works.

- Is the private access road, Carter Road, in the Shire of Mundaring?

The Acting Executive Manager Development Services confirmed this is correct.

13.4 CORPORATE SERVICES

13.4.1 Accounts & Statements of Accounts - 1 February 2023 to 28 February 2023

Clarification was sought in relation to:

- Why are we still paying for services from Talis Consultants Pty Ltd?

The Executive Manager Corporate Services advised that Talis Consultants are doing a range of work for the Shire, including for the AGN 962 DREAWA submissions.

Council Forum Meeting Notes
08 March 2023



Reference	Page #	Date	Details Reference	Question	Query By	Answer	Answered By
EFT46327	411		Bunnings	Esky Hybrid Cooler Jug, very expensive what is it??	Cr Tinetti	The order is for 50 Water Bottles (eskys) @ \$19.95 each excluding GST, that are encased with an insulated outer skin that is removable.	Colin
	408		Water Corp, for Wundowie public toilets 22/12/22 - 15/02/23, \$2872.86	Why so much?	Cr Williams	This Meter also is used to water the lawn and garden around the toilets, the timing of the programme was adjusted downwards last month so this bill should be less in future.	Shane
EFT46322	410		Beatum Pty Ltd for 2022 staff Christmas party - \$5308.50	What was this for? And could we please have the total amount paid for the party by the shire?	Cr Williams	1. This was the payment for the Grand Hotel where the Christmas Party was held. 2. This was the total cost of the event, food and drinks, kids entertainment and venue hire where all included in the \$5,308.50, about 100 staff and Councillors attended.	Ian
EFT46327	411		Bunnings for eskies - \$1097.50	I think I saw this was for 50 but what are they for?	Cr Williams	They are 50 Esky Water bottles with removable external insulation, purchased for Depot staff.	Colin
EFT46433	429		Matrix Productions Australia - black corporate wool drape for the citizenship ceremony - \$924.00	What is this for please?	Cr Williams	This was required for the BKB round room so we could block out the kitchen for the ceremony, this gave staff the ability to create more space in the venue by reconfiguring the setup.	Ian
EFT46489	438		Intersectional Linemarkers for Spencer's Brook Rd audible line marking claim one - \$250574.85	Is this plus EFT46554 from page 449 for \$6803.08 the total payment? How much will the shire be liable for?	Cr Williams	1. The total of the payment is \$250,574, 50% retainer refunded 6,803.08 plus the additional 50% of the retainer that will be held for 12 Months. 2. project was fully funded by mains road for total expenditure of \$1,413,692	Chan
EFT46499	439		Main Roads WA for refund of black spot funding for Mitchell Ave - \$5507.70	How did the overpayment occur?	Cr Williams	This was 2/3 funded by Main Roads, the Job came in under budget, as such surplus funds received where refunded, this has been accounted for in the B/review presented to the March OMC.	Chan
EFT46511	441		Regional Physiotherapy... for [same] - \$99.00	- Is this for senior sports funding?	Cr Williams	Yes this was a senior sports Application	David
Credit/card	462		EMCommS credit card payment to JB Hi-Fi for movie for Australia Day - \$19.98	What was done with the movie following the event?	Cr Williams	This got stuck in the DVD player and has been requested to be returned from the supplier, on return it will be used by the Library.	Ian

Council Forum Meeting Notes
08 March 2023



13.4.2 Financial Statements for the period 1 February 2023 to 28 February 2023

Nil.

13.4.3 Budget Review 2022/23

Clarification was sought in relation to:

- Do we usually have workshops regarding the Budget or just a meeting?

The Executive Manager Corporate Services advised that the item is presented directly to the forum and Council meeting, with no workshops.

- In relation to the Operating Expense Accounts first point referring to increases due to termination of long-term employees, was this not already catered for by having a reserve that we could transfer the money from?

The Executive Manager Corporate Services advised that we do have the reserve but in this case, it was not used.

- Will the DREAWA funding have an impact going forward because it took so long to be received?

The Executive Manager Corporate Services advised that the extension will be catered for in the 23/24 budget and the revenue can be adjusted to match the expenditure. This will not impact cashflow.

- In regard to the net result, is this taking into consideration the budget at the end of the year?

The Executive Manager Corporate Services confirmed this is correct. Discrepancies will be reviewed as part of next year's budget process.

- In regard to Council receiving a bridge grant from Western Australian Grants Commission for works on Old York Road bridge, has this been planned in the works?

The Acting Executive Manager Engineering Services advised that this was identified by Main Roads. The grant would be for a refurbishment not a renewal of the bridge.

- Will the revenue for the Old Pool House be carried forward to the next budget?

Council Forum Meeting Notes
08 March 2023



The Executive Manager Corporate Services confirmed this is correct.

13.5 COMMUNITY SERVICES

13.5.1 Financial support for the 2023 National Ballooning Championships

Clarification was sought in relation to:

- Whether the Shire knew that we were going to have to underwrite the event for \$100,000?

The Executive Manager Community Services advised that at the time they presented their budget to Tourism WA there was no shortfall, however costs have increased over the years of postponement. Council has contributed to the ballooning event in the past. For the Nationals Ballooning Event taking place this May the Shire contributed \$40,000. Council officers advised they have recently had a discussion with representatives from Northam Ballooning Event Inc. who are proposing to request a reduced amount prior to the full Council meeting.

- Is this the same event that we have funded someone to pitch for Northam to host overseas?

The Executive Manager Community Services confirmed this is correct, the Shire of Northam supported a representative to make a bid for the event.

- Do we have something in the budget for the event?

The Executive Manager Community Services advised that there is no budget currently as it would be a consideration for 23/24 budget. In relation to the Women's Worlds we have discussed the possibility of utilising smaller activations, such as buskers down the main street, rather than one big activation. We are also taking into consideration the fact that the Northam Agricultural show and the football grand finals are at that time. We have been advised that the international competitors may not be as interested in participating in something like the Glow event. But anything that will occur will come through Council first, there is currently no allocation for the Worlds event.

- Would the Shire normally be paying for the fuel (gas) for competitors?

The Chief Executive Officer advised that it depends on the event. However this is an event cost.

Council Forum Meeting Notes
08 March 2023



- Is there an opportunity to get a gas supplier involved as a sponsor?

The Chief Executive Officer advised that the Shire is not involved in arranging sponsors for the event.

- Is there potential for the cost to be less than \$100,000?

The Executive Manager Community Services confirmed this is correct. We are expecting the cost to reduce to around \$30,000 to \$40,000.

- When the statistics refer to a region, what area does this encompass?

The Executive Manager Community Services advised that it would be the Avon Valley region and surrounding areas. This is just an estimate in numbers provided by WA Tourism based on the last event.

- They have previously sought and gained financial support from Tourism WA, can they go back to them for funding?

The Executive Manager Community Services advised that Tourism WA have paid a small extra payment in relation to the postponement of the event.

- Is there anything that we can give in-kind instead of money?

The Executive Manager Community Services advised this has already been factored into the budget.

- Can we reduce the total contribution?

The Chief Executive Officer advised that the decision is up to Council. The National Ballooning Championship team are trying to move ahead with confidence that the financial support is there.

- Is it possible to see the original application?

The Chief Executive Officer confirmed this.

- In regards to the issues with accommodation for people coming to this event, is the Council offering free camping?

The Executive Manager Community Services advised that we are offering free camping at some ovals, but this is not appropriate accommodation for the competitors.

Council Forum Meeting Notes
08 March 2023



14 MATTERS BEHIND CLOSED DOORS

RECOMMENDATION / MOTION

Minute No: C.4674

Moved: Cr Ryan

Seconded: Cr Mencshelyi

That Council, in accordance with section 11.1(i) of the Shire of Northam Standing Orders Local Law 2018 and Section 5.23 (2) (A) and (C) of the Local Government Act 1995, meet behind closed doors to consider agenda items:

- 14.1 - Financier's Side Deed – Northam Country Club, 15 Wood Drive, Northam – as it related to a contract entered into, or which may be entered into, by the local government and which relates to a matter to be discussed at the meeting.
- 14.2 – Chief Executive Officer Review Committee meeting held on 15 February 2023 – as it is a matter affecting an employee or employees.

CARRIED 9/0

14.1 FINANCIER'S SIDE DEED - NORTHAM COUNTRY CLUB, 15 WOOD DRIVE, NORTHAM

Refer to Confidential Addendum.

14.2 CHIEF EXECUTIVE OFFICER REVIEW COMMITTEE MEETING HELD ON 15 FEBRUARY 2023

Refer to Confidential Addendum.

RECOMMENDATION / MOTION

Minute No: C.4675

Moved: Cr Mencshelyi

Seconded: Cr Galloway

That Council move out from behind closed doors.

CARRIED 9/0

**Council Forum Meeting Notes
08 March 2023**



15 MOTIONS OF WHICH PREVIOUS NOTICE HAS BEEN GIVEN

Nil.

16 URGENT BUSINESS APPROVED BY DECISION

Nil.

17 DECLARATION OF CLOSURE

There being no further business, the Shire President, Cr C R Antonio, declared the meeting closed at 6:55pm.

10.3 NOTES FROM THE STRATEGIC COUNCIL MEETING HELD 22 FEBRUARY 2023

RECOMMENDATION / COUNCIL DECISION

Minute No: C.4680

Moved: Cr M P Ryan

Seconded: Cr M I Girak

That Council receive the notes from the Strategic Council meeting held on Wednesday, 22 February 2023.

CARRIED 8/0

11 ITEMS BROUGHT FORWARD FOR THE CONVENIENCE OF THOSE IN THE PUBLIC GALLERY

The Shire President, Cr C R Antonio, advised that the following agenda items would be brought forward:

- Item 13.1.3 - Request to Operate a Gyrocopter - Northam Airport
- Item 13.3.1 - Proposed Scheme Amendment 18 - 54 Byfield St, Northam

12 REPORTS OF COMMITTEE MEETINGS

12.1 COMMUNITY SAFETY COMMITTEE MEETING HELD ON 14 FEBRUARY 2023

Receipt of Minutes:

RECOMMENDATION / COUNCIL DECISION

Minute No: C.4681

Moved: Cr M P Ryan

Seconded: Cr H J Appleton

That Council receive the minutes from the Community Safety Committee meeting held on 14 February 2023.

CARRIED 8/0

Adoption of Recommendations:

RECOMMENDATION / COUNCIL DECISION

Minute No: C.4682

Moved: Cr M P Ryan

Seconded: Cr D J Galloway

That Council:

- 1. Accept the Minutes of the Shire of Northam Community Safety Committee meeting held Thursday, 15 November 2022 be confirmed as a true and correct record of that meeting.**
- 2. Accepts the update of the Community Safety and Crime Prevention Plan for October – December 2022 as provided.**
- 3. Supports and promotes awareness of 16 Days in WA campaign events and activities in the Shire of Northam from 25 November 2023 – 10 December 2023.**
- 4. Accepts the updates of the Community Safety Committee Working Groups.**

CARRIED 8/0



Shire of Northam
Heritage, Commerce and Lifestyle

Shire of Northam

Minutes

Community Safety Committee

14 February 2023

Community Safety Committee Meeting Minutes
14 February 2023



DISCLAIMER

In certain circumstances members of the public are not entitled to inspect material, which in the opinion of the Chief Executive Officer is confidential and relates to a meeting or a part of a meeting that is likely to be closed to members of the public.

No responsibility whatsoever is implied or accepted by the Shire of Northam for any act, omission, statement or intimation occurring during Council or Committee meetings.

The Shire of Northam disclaims any liability for any loss whatsoever and howsoever caused arising out of reliance by any person or legal entity on any such act, omission or statement of intimation occurring during Council or Committee meetings.

Any person or legal entity who acts or fails to act in reliance upon any statement, act or omission made in a Council or Committee meeting does so at that person's or legal entity's own risk.

In particular and without derogating in any way from the broad disclaimer above, in any discussion regarding any planning application or application for a licence, any statement or intimation of approval made by any member or Officer of the Shire of Northam during the course of any meeting is not intended to be and is not taken as notice of approval from the Shire of Northam.

The Shire of Northam advises that anyone who has any application lodged with the Shire of Northam must obtain and should only rely on WRITTEN CONFIRMATION of the outcome of the application and any conditions attaching to the decision made by the Shire of Northam in respect of the application.

The Shire of Northam advises that any plans or documents contained within this agenda may be subject to copyright law provisions (*Copyright Act 1968*, as amended) and that the express permission of the copyright owner(s) should be sought prior to their reproduction. It should be noted that copyright owners are entitled to take legal action against any persons who infringe their copyright. A reproduction of material that is protected by copyright may represent a copyright infringement.

Community Safety Committee Meeting Minutes
14 February 2023



Contents

1.	DECLARATION OF OPENING.....	4
2.	ACKNOWLEDGEMENT TO COUNTRY.....	4
3.	ATTENDANCE.....	4
3.1	APOLOGIES	4
3.2	APPROVED LEAVE OF ABSENCE.....	5
3.3	ABSENT.....	5
4.	DISCLOSURE OF INTERESTS.....	5
5.	CONFIRMATION OF MINUTES	5
5.1	COMMITTEE MEETING HELD 15 NOVEMBER 2022.....	5
6.	COMMITTEE REPORTS.....	6
6.1	COMMUNITY SAFETY & CRIME PREVENTION UPDATE.....	6
6.2	COMMUNITY SAFETY WORKING GROUP UPDATES.....	12
6.4	AGENCY UPDATES	18
7.	URGENT BUSINESS APPROVED BY PERSON PRESIDING OR BY DECISION.....	20
8.	DATE OF NEXT MEETING.....	20
9.	DECLARATION OF CLOSURE.....	21

UNCONFIRMED

Community Safety Committee Meeting Minutes
14 February 2023



1. DECLARATION OF OPENING

The Presiding member Cr Julie Williams declared the meeting open at 11:04am

2. ACKNOWLEDGEMENT TO COUNTRY

The Shire of Northam would like to acknowledge the Traditional Owners of the land, the Ballardong and Whadjuk people of the Nyoongar nation and pay our respects to Elders, past present and emerging.

3. ATTENDANCE

Committee Members:

Presiding Member	Cr Julie Williams
Northam Police	SSGT Ross Eastman
DLGSC	Kim Sharpe
LDAG	Rose Power
Community Representative	Elizabeth Hoek
Community Representative	Ulo Rumjantsev
Northam PCYC	Jane Atterby
Northam Youth Wellbeing Plan	Jo-Anne Woodruff

Committee Ex-Officio Members:

Executive Manager Community Services	Jo Metcalf
Manager Community Development & Tourism	Jaime Hawkins
Senior Ranger	Kellee Walters
Avon Community Services	
Department of Communities –	
Housing Authority	Christine Frank
Child Protection & Family Support	Rachel Collins

Staff:

Community Services Administration/ Project Officer	Elijah Moorhead
---	-----------------

Guests:

WA Country Health Service – Wheatbelt	Danielle Mactaggart
Wheatbelt District Police Office	Insp. Jason Beesley
Wheatbelt District Police Office	SSGT Martin Glynn

3.1 APOLOGIES

Wundowie Police	SGT Aaron Honey
Bridgeley Church of Christ	Kym Edwards

Community Safety Committee Meeting Minutes
14 February 2023



WA Country Health
Department of Education
Northam Chamber of Commerce
Northam Roadwise Committee

Shani Toki
Sharon Bray
Melanie Jones
Cliff Simpson

3.2 APPROVED LEAVE OF ABSENCE

Nil.

3.3 ABSENT

Nyoongar Cultural Advisory Representative
Chief Executive Officer
Councillor

Donna Moody
Jason Whiteaker
Cr Attila Mencshelyi

4. DISCLOSURE OF INTERESTS

Nil

5. CONFIRMATION OF MINUTES

5.1 COMMITTEE MEETING HELD 15 NOVEMBER 2022

COMMITTEE DECISION

Minute No: 100

**Moved: Ulo Rumjantsev
Seconded: Elizabeth Hoek**

That the minutes of the Shire of Northam Community Safety Committee meeting held Thursday, 15 November 2022 be confirmed as a true and correct record of that meeting.

CARRIED 8/0

DISCUSSION

Elizabeth Hoek suggested that it should be noted in the Committee Decision for Item 6.1 (minute no 096), which update of the plan they have accepted, i.e. July – September 2022. It was recommended that this be added to future agendas and minutes.

Community Safety Committee Meeting Minutes
14 February 2023



6. COMMITTEE REPORTS

6.1 COMMUNITY SAFETY & CRIME PREVENTION UPDATE

File Reference:	1.3.12.1
Reporting Officer:	Jaime Hawkins, Manager Community Development & Tourism
Responsible Officer:	Jo Metcalf, Executive Manager Community Services
Officer Declaration of Interest:	Nil
Voting Requirement:	Simple majority
Press release to be issued:	No

BRIEF

To update the committee on the Community Safety and Crime Prevention Plan actions.

ATTACHMENTS

Nil.

A. BACKGROUND / DETAILS

This Committee Report aligns with the four (4) focus areas of the Community Safety & Crime Prevention Plan 2022 – 2026.

B. CONSIDERATIONS

B.1 Strategic Community / Corporate Business Plan

Outcome 1: A safe community

Objective 1.1: Play our role in promoting a safe and crime free community

B.2 Financial / Resource Implications

There is a budget allocation of \$10,000 for Community Safety Plan Initiatives.

B.3 Legislative Compliance

Nil.

B.4 Policy Implications

Nil.

Community Safety Committee Meeting Minutes
14 February 2023



B.5 Stakeholder Engagement / Consultation

There has been ongoing engagement and consultation with stakeholders of the Community Safety and Crime Prevention Plan.

B.6 Risk Implications

Risk Category	Description	Rating (likelihood x consequence)	Mitigation Action
Financial	Community Safety Initiatives run over budget	Possible (3) x Insignificant (1) = Low (3)	Check budget regularly and check expenditure. Apply for increased budget allocation if likely to require additional funds.
Health & Safety	Crime rates increase & the plan does not improve community safety.	Possible (3) x Minor (2) = Moderate (6)	The Committee & Shire staff work in close partnership with local Police and other agencies to implement targeted strategies to reduce crime & anti-social behaviour.
Reputation	Community safety is an area of public concern. The Community Safety & Crime Prevention Plan is not deemed to improve safety.	Possible (3) x Medium (3) = Moderate (9)	Cross agency Community Safety and Crime committee work together to implement strategies to reduce community crime and anti-social behaviour.
Service Interruption	Nil	Nil	Nil
Compliance	Nil	Nil	Nil
Property	Nil	Nil	Nil
Environment	Nil	Nil	Nil

C. OFFICER'S COMMENT

The Shire of Northam's Community Development Officer to provide an update on recent activities.

Focus Area 1: Building Partnerships & Internal Capacity

Quarterly Shire of Northam Crime Statistics (October - December) presented below

Community Safety Committee Meeting Minutes

14 February 2023



- Monthly figures on the reports of crime within the Shire of Northam boundaries are compiled and supplied to the Shire by WALGA. Data excludes family and domestic assaults.
- Reports of crime for this quarter have remained steady over the past 5 years.
- There was a spike in arson offences in December. Drug offences dropped this quarter compared to the last. Stealing offences were high in October, November, but dropped in December.

Crime Category	Crime Type	Oct-22	Nov-22	Dec-22
Arson	Cause bushfire	2	2	10
Arson	Cause damage by fire	0	2	0
Arson	Other fire related offences	0	0	0
Assault	Non-family	10	9	9
Burglary	Dwelling	8	9	2
Burglary	Non-Dwelling	3	5	1
Deprivation of Liberty	Deprivation of Liberty	0	0	0
Deprivation of Liberty	Kidnapping / Child Stealing	0	0	0
Disorderly Conduct	Disorderly behaviour	0	5	0
Drug Offences	Cultivate or manufacture drugs	0	1	2
Drug Offences	Drug dealing	2	0	1
Drug Offences	Drug possession	5	6	12
Drug Offences	Possession of drug paraphernalia	3	3	8
Drug Offences	Other drug offences	0	0	4
Graffiti	Graffiti	0	1	1
Homicide	Murder	0	0	0
Liquor Offences	Liquor Offences (Licensee)	0	0	0
Liquor Offences	Liquor Offences (other)	0	0	0
Offences Against Animals	Offences Against Animals	0	0	0
Property Damage	Criminal Damage	6	7	7
Property Damage	Damage	14	13	4
Robbery	Business	0	0	0
Robbery	Non-business	0	0	0
Sexual Offences	Historical sexual offences	0	0	0
Sexual Offences	Recent sexual offences	1	1	1
Stealing	From dwelling	5	8	4
Stealing	From motor vehicle (contents or parts)	3	4	
Stealing	From retail premises or place (shoplift)	17	20	5
Stealing	From other premises or place	12	15	7
Stealing of Motor Vehicle	Stealing of Motor Vehicle	1	1	2
Transport Offences	Driving Causing Bodily Harm	0	0	0
Transport Offences	Drunk/Drug Driving	3	0	1
Transport Offences	Driver's Licence Offences	1	1	1
Transport Offences	Fail to stop or give way	0	1	0

Community Safety Committee Meeting Minutes

14 February 2023



Transport Offences	Unsafe Driving	4	0	6
Transport Offences	Vehicle licence offences	0	0	1
Transport Offences	Seatbelt/Helmet Offences	0	0	0
Transport Offences				
TOTAL (No. of counts)		100	114	89

An update to be provided by Police representatives present.

Focus Area 2: Safer Places & Spaces

- Objective 2.2: Actions 1 & 2 – Graffiti incident on the Jackson Harvey, Aerial Playground mural in Gordon Place. Graffiti was reported to Police & was cleaned within 48 hours.
- Objective 2.2: Action 4 – registered as Clean Up Australia Day supporting Council. Will provide tools and assist with removal of rubbish to groups wishing to participate. In discussion with events team to organise a community clean up event. Likely between the Motorsport Festival and the National Ballooning Championships.
- Outstanding actions – meet with Development Services to embed CPTED into planning & development process. Meet with Engineering Services regarding lightening audit to ensure community safety outcomes. These meetings have been scheduled. Any updates will be provided at the next community safety committee meeting.

Focus Area 3: Community Education & Awareness

- Objective 3.1, Action 1 – Continued monthly Community Safety Corner articles appearing in the Northam Advertiser. Topics covered in the articles this quarter are: summer safety & back to school road safety (written by the Roadwise Committee). The March issue is to focus on responsible dog ownership from the Shire Rangers, given recent local concern about this.
- Outstanding action – E-scooter safety article in the Northam Advertiser.
- Action 2 – Liaising with Cliff Simpson from Roadwise to plan a community road safety forum during road safety week (14th – 21st May 2023). Forum to include emergency services. To be further discussed at Item 6.2. A community safety forum will also be arranged for October with a focus topic to be determined.
- Objective 3.2, Action 3 – Neighbours Day is 26 March 2023. Toolkits available through Relationships Australia, which Council will promote.
- Objective 3.3, Actions 1 & 2 - Working with library services who have been proactive in providing education and support for the vulnerable in relation to scams awareness and cyber safety for children. Cyber safety workshop held 7 February to tie in with back to school. Participated in scams awareness week and developed an information stand following the Optus data breach, helping people with what to do if effected.

Community Safety Committee Meeting Minutes

14 February 2023



Focus Area 4: Antisocial Behaviour

- Objective 4.1, Action 2 – On Country Youth at Risk Camp held in December. To be further discussed at Item 6.2
- Action 5 – School holiday activities delivered, including Back to School laser tag event. Collaborations with Northam PCYC, DLGSC, Police, Dept. of Education & the Northam Recreation Centre. To be further discussed at Item 6.2

COMMITTEE DECISION

Minute No: 101

Moved: Ross Eastman

Seconded: Jane Atterby

That Council accepts the update of the Community Safety and Crime Prevention Plan for October – December 2022 as provided.

CARRIED 8/0

DISCUSSION

Kellee Walters Question: why is it that domestic violence isn't included in the WALGA statistical reports?

SSGT Ross Eastman is almost certain that it is on the forward-facing documents that are supplied to WALGA.

Jaime Hawkins will make inquiries and will provide an update at the next meeting.

Update from SSGT Ross Eastman, OIC Northam Police Station:

- 2 locals were charged with 6 out of the 10 arson offences, 1 was charged with a \$1000 fine and the other remains in custody and is progressing through the courts.
- Burglary dropped in December to 2 offences, no-one has been charged in relation to them but is still under investigation. But several people were charged during October & November.
- 60% of all stealing reports have resulted in prosecution. Puts the success down to Operation Heatshield which increases budget to pay overtime and allows the police to increase their presence and availability. Northam Police have implemented a new process in which most shop owners can call the station directly and getting an immediate response. Also issuing a barring notice, followed by trespassing offence and then finally burglary as it carries a higher penalty.

Jo Metcalf question: Is it mainly adults or children?

Community Safety Committee Meeting Minutes
14 February 2023



SSGT Ross Eastman: Combination of both, but mainly adults.

Christine Frank suggested to maybe focus on making food more accessible to limit the stealing of it.

Martin Glynn replied that most of the stealing offences are recidivist offenders and that the barring notices have had a huge impact on reducing all burglary offences. The desire to purchase drugs subsequently leads to the increase of food theft.

Jo Metcalf asked if the police would be involved in the meetings with the Shire's Engineering and Development Services to provide insight and feedback regarding community safety developments such as adding more lighting & Crime Prevention Through Environmental Design (CPTED).

SSGT Ross Eastman agreed that it would be beneficial for police representatives to attend.

Rose Power volunteered to assist in collating the information for the E-scooter article that will be published in the Northam Advertiser.

Community Safety Committee Meeting Minutes

14 February 2023



6.2 COMMUNITY SAFETY WORKING GROUP UPDATES

File Reference:	1.3.12.1
Reporting Officer:	Jaime Hawkins Community Development Officer
Responsible Officer:	Jo Metcalf, Executive Manager Community Services
Officer Declaration of Interest:	Nil
Voting Requirement:	Simple majority
Press release to be issued:	Nil

BRIEF

For the Committee to be provided with updates from the Community Safety Working Groups.

ATTACHMENTS

Nil.

A. BACKGROUND / DETAILS

Objective 1.1 of the Shire of Northam Community Safety & Crime Prevention Plan 2022 – 2026 is to “work with WA Police Force & key stakeholder to share knowledge, resources, plan & implement community safety & crime prevention initiatives”

Actions 4 & 5 of this objective are to:

- Identify relevant existing networking or advisory groups and connect with these to collaborate on activities to target specific issues (for example youth offending).
- Where no key networking or advisory group exists, identify the key stakeholders for the area of concern and establish working groups or partnerships to initiate action.

The following working groups were accepted to work on priority actions of the Community Safety & Crime Prevention Plan 2022 – 2026:

- Youth at risk Working Group
- Wheatbelt Road Safety Alliance
- Community Youth Wellbeing Plan Group

B. CONSIDERATIONS

B.1 Strategic Community / Corporate Business Plan

Outcome 1: A safe community

Community Safety Committee Meeting Minutes
14 February 2023



Objective 1.1: Play our role in promoting a safe and crime free community

B.2 Financial / Resource Implications

There is a budget allocation of \$10,000 for Community Safety Plan Initiatives.

B.3 Legislative Compliance

Nil.

B.4 Policy Implications

Nil.

B.5 Stakeholder Engagement / Consultation

Nil

B.6 Risk Implications

Risk Category	Description	Rating (likelihood x consequence)	Mitigation Action
Financial	Community Safety Initiatives run over budget	Possible (3) x Insignificant (1) = Low (3)	Check budget regularly and check expenditure. Apply for increased budget allocation if likely to require additional funds.
Health & Safety	Crime rates increase & the plan does not improve community safety.	Possible (3) x Minor (2) = Moderate (6)	The Committee & Shire staff work in close partnership with local Police and other agencies to implement targeted strategies to reduce crime & anti-social behaviour.
Reputation	Community safety is an area of public concern. The Community Safety & Crime Prevention Plan is not deemed to improve safety.	Possible (3) x Medium (3) = Moderate (9)	Cross agency Community Safety and Crime committee work together to implement strategies to reduce community crime and anti-social behaviour.
Service Interruption	Nil	Nil	Nil
Compliance	Nil	Nil	Nil

Community Safety Committee Meeting Minutes

14 February 2023



Property	Nil	Nil	Nil
Environment	Nil	Nil	Nil

C. OFFICER'S COMMENT

Youth At Risk

The Youth at Risk Working Group in collaboration with Moorditj Youth coordinated a camp for youth at risk that took place in December at Boshack in Bolgart.

January school holiday activities and back to school initiative.

A further update is to be provided by representatives.

Road Safety

A Day of Action for heavy vehicles was held in November, along with a Wheatbelt Police campaign raising awareness of driver fatigue and inattention

Roadwise have been engaging in further discussion with stakeholders around 30km/hour school zones.

National Road Safety Week 14th – 21st May. Town Teams Turn Your Town Yellow funding available.

A further update is to be provided by representatives.

Community Youth Wellbeing Plan Group

The Northam Youth Wellbeing Plan is currently undergoing a review. The next review meeting is scheduled for 23 March. The focus of the new plan will be determined by the committee based upon local data, and therefore may no longer have a focus on youth. The outcome of the review will be reported at the next Community Safety Committee meeting.

Family & Domestic Violence

At the last meeting held 15 November 2022, the Family & Domestic Violence Working Party from the Human Services Managers Forum was removed as a working group of this committee due to its larger regional focus. It is the Officer's recommendation that a family & domestic violence working group is not a priority of the Community Safety Committee for 2023 and should not be established at this stage. The Committee should continue to support the Youth at Risk Working Group and the Road Safety Alliance and wait for the completion of the review process for the Youth Wellbeing Plan before establishing any new working groups. Whilst it is not a matter directly targeted in the Community Safety & Crime Prevention Plan 2022 -2026, it is acknowledged that family & domestic violence is a serious community safety issue that is often connected to several of the plan's objectives. It is proposed

Community Safety Committee Meeting Minutes

14 February 2023



that an offer be made to the Chair of the Family & Domestic Violence Working Party that the Shire of Northam Community Safety Committee is available if needed to support and contribute to any projects of the working party locally, and that any important information or updates can be shared through this committee.

RECOMMENDATION

That Council accepts the updates of the Community Safety Committee Working Groups.

COMMITTEE DECISION

Minute No: 102

Moved: Jo Woodruff

Seconded: Ulo Rumjantsev

That Council:

- 1. Supports and promotes awareness of 16 Days in WA campaign events and activities in the Shire of Northam from 25 November 2023 – 10 December 2023.**
- 2. Accepts the updates of the Community Safety Committee Working Groups.**

CARRIED 8/0

Rachel Collins joined the meeting at 11:23am

DISCUSSION

Youth at Risk – update provided by Jane Atterby

- The camp at Boshack was a great learning experience and was enjoyed by the youth and elders that attended.
- 13 kids stayed out of the 19 that went. 6 were removed for bad behaviour.
- Looking at changing the name of Youth at Risk to something like Youth Engagement
- During the school holidays PCYC held a pool party after which the police ran games in the Northam Rec-Centre and will look at doing the same again during this year's holidays.
- A blue light disco was held in January with hopes to improve it next time.
- The Back to School Laser Tag was very successful and had about 120-130 kids attend. The schools were in attendance giving out information.
- Backpacks with equipment were given to the schools for those in need and they were distributed wheatbelt wide.
- New Department of Education program called SALS (School of Alternative Learning Settings) in which schools can refer kids with serious

Community Safety Committee Meeting Minutes

14 February 2023



behavioural issues to attend an intense 5-10 week program to modify behaviour and get them back into mainstream learning. The program is for up-to 10 students and targeted for kids' years 7-10. It is being run at PCYC.

Joanne Woodruff requested that Jess Daniels from Holyoake be invited to future Youth at Risk meetings.

Road Safety update

Jaime Hawkins read update received from Cliff Simpson via email:

The Northam RoadWise Committee wrote to Ministers Papalia, Safiotti, Darren West and Mia Davies, Northam Police and Main Roads advocating for a trial of 30km/h school zones in Northam.

Main Roads sent a response to Shire CEO Jason Whiteaker, saying that the legislated speed for a school zone is 40km/h.

I received phone responses from Darren West and Mia Davies' offices.

WALGA RoadWise management received a Ministerial question vis the Road Safety Commission.

The Road Safety Commission expressed interest in a trial. WALGA RoadWise has had conversations with Main Roads Northam and Head Office in Perth. Main Roads are concerned about the precedent this trial might set.

I approached the Education Department via Sharon Bray, who said she'd approach her Director.

I met with Shire CEO and former engineer Scott Patterson; they believe more evidence must be gathered, and the way the matter can be elevated to Council is through the Community Safety Committee.

I discussed this with Mohammad Siddiqui, Regional Manager MRWA. He said this has now reached the Director of Main Roads and there are many implications in this proposal.

At this stage I believe it is too soon to elevate this to Council, more evidence needed and support from Education Department and Police District Office would be helpful.

Cliff Simpson will provide an update at the next community safety committee meeting and if the committee are supportive of a trial, he will make a motion.

Ulo Rumjantsev advised the committee that he sent Cliff Simpson an article regarding Queensland putting speed cameras in school zone. Trialling in 30 school areas and wanting to eventually reduce the school zone speed from 40 to 30 to 20.

Community Safety Committee Meeting Minutes

14 February 2023



SSGT Martin Glynn noted that an update on the Day of Action was provided at last meeting but added that the day was more about educating police on how to engage with heavy haulage contractors vehicles and to send them a message about the importance of compliance.

Youth Wellbeing Plan – update provided by Jo Woodruff

Review meeting was held at the end of November 2022.

- The review of the previous plan was excellent as they achieved a lot of the outcomes outlined in the plan.
- Committee representatives have been asked to bring statistical information and anecdotal data to help develop the priorities of the next plan which will be drafted and discussed at the next meeting in March 2023.
- Jo Woodruff mentioned herself and Jo Drayton believe the current community perception survey is cumbersome and will look to streamline and improve the process.

Family and Domestic Violence

- Jo Woodruff sits on the committee and chairs one of the subgroups and believes she will be able to provide updates when required to keep the Community Safety Committee up to date.

Christine Frank question: is the Shire doing anything for the 16 days in WA violence against women campaign? (25th November – 10th December)

Jo Metcalf – the lights on the suspension bridge and Create 298 office have been programmed to turn orange during the campaign but have no plan to do an event at this stage.

Christine Frank – Department of Communities with Share & Care have started working on their event for the campaign to be located at the Village Green.

Jo Metcalf suggested that for the next financial year – potentially asking for a budget allocation to assist in working with the Community Safety Committee on the event.

Jo Metcalf - the Shire can provide support in the form of social media to increase awareness and suggested the Committee coordinate any event – as the Shire's events team do not have capacity.

Community Safety Committee Meeting Minutes
14 February 2023



6.4 AGENCY UPDATES

File Reference:	1.3.12.1
Reporting Officer:	Jaime Hawkins Community Development Officer
Responsible Officer:	Jo Metcalf, Executive Manager Community Services
Officer Declaration of Interest:	Nil
Voting Requirement:	-
Press release to be issued:	Nil

BRIEF

To provide an opportunity for staff, and external groups/agencies to discuss pertinent matters relating to the safety of the local community.

ATTACHMENTS

Nil

A. BACKGROUND / DETAILS

A benefit of committees such as the Community Safety Committee is the ability for external groups to provide an update on initiatives, challenges and opportunities that the local community is facing, relaxing the burden of reporting such updates during Council meetings.

Relevant external groups and agencies may present pertinent matters of discussion related to the area of community safety & crime prevention, as well as any other programs or activities relating to external groups/agencies.

B. CONSIDERATIONS

B.1 Strategic Community / Corporate Business Plan

Outcome 1: A safe community

Objective 1.1: Play our role in promoting a safe and crime free community

B.2 Financial / Resource Implications

Nil.

Community Safety Committee Meeting Minutes
14 February 2023



B.2 Financial / Resource Implications

Nil.

B.3 Legislative Compliance

Nil.

B.4 Policy Implications

Nil.

B.5 Stakeholder Engagement / Consultation

External groups and agencies represented on the committee are encouraged to provide an update during the committee meetings.

B.6 Risk Implications

Risk Category	Description	Rating (likelihood x consequence)	Mitigation Action
Financial	N/A	N/A	N/A
Health & Safety	N/A	N/A	N/A
Reputation	N/A	N/A	N/A
Service Interruption	N/A	N/A	N/A
Compliance	N/A	N/A	N/A
Property	N/A	N/A	N/A
Environment	N/A	N/A	N/A

C. OFFICER'S COMMENT

N/A

DISCUSSION

DLGSC - Kim Sharpe:

- DLGSC has teamed up with volunteering WA to attract volunteers, identify issues and provide increased opportunities.
- Will be having session all over the Wheatbelt with Northam's being held on the 15th of March. There is a requirement to register for the workshop.

WA Police Wheatbelt District:

SSGT Kim Mead – we are still working on the Men's Respite Centre program to provide male perpetrators with somewhere safe to stay and offer counselling and exit strategies.

SSGT Martin Glynn – you will see an increase in high visibility roadside breath testing in the next 3 months.

Holyoake/Youth Wellbeing - Joanne Woodruff:

Community Safety Committee Meeting Minutes

14 February 2023



Holyoake have Recognise & Respond training scheduled for 4th of April in Moora for full day course and fully funded by the Mental Health Commission.

New drug awareness campaign called Growing Brain that talks about the effects of cannabis consumption on the developing brain with posters and fact sheets available.

Spread campaign is out of market and will look to launch a new campaign in the next couple months.

Volatile Substance Use has a new app in development and Holyoake will make sure members of the committee are sent links to download it upon release.

Ulo would like to see an article on roundabout use in the local paper. Police support the notion of providing more education on indicating through roundabouts to the public.

Shire of Northam Rangers - Kellee Walters

Kellee provided perspective on what the rangers do on a day-to-day basis given the recent incident with the dog attack on the cygnet.

- Rangers have had 118 prosecutions on dog infringements.
- Rangers impounded 100 dogs and 65 cats.
- New social media campaign to highlight the above.
- Rangers have met with the new Police LLC.
- 100 used syringes have been found at the Ag shed pavilion and police have been advised.
- Firebreaks have been inspected for this year.

Cr Julie Williams asked if the stats can be made public.

Jo Metcalf replied that we can and they will be used in the future.

7. URGENT BUSINESS APPROVED BY PERSON PRESIDING OR BY DECISION

Nil.

8. DATE OF NEXT MEETING

11am Tuesday 16 May 2023 at the Northam Recreation Centre.

Community Safety Committee Meeting Minutes
14 February 2023



9. DECLARATION OF CLOSURE

There being no further business, the Presiding Member, Cr Julie Williams declared the meeting closed at 12:09pm.

"I certify that the Minutes of the Community Safety Committee Meeting of held on Tuesday, 14 February 2023 have been confirmed as a true and correct record."

_____ Presiding Member

_____ Date

UNCONFIRMED

12.2 AUDIT AND RISK MANAGEMENT COMMITTEE HELD ON 23 FEBRUARY 2023

Receipt of Minutes:

RECOMMENDATION / COUNCIL DECISION

Minute No: C.4683

Moved: Cr C R Antonio

That Council receive the minutes from the Audit and Risk Management Committee meeting held on 23 February 2023.

CARRIED 8/0

Adoption of Recommendations:

RECOMMENDATION / COUNCIL DECISION

Minute No: C.4684

Moved: Cr C R Antonio

That Council:

1. Accept that the minutes of the Audit & Risk Management Committee meeting held on 16 December 2022 be confirmed as a true and correct record of that meeting.
2. Receive the update as provided in the monthly Compliance Calendar Report.
3. Receive the February 2023 Shire of Northam Risk Register update.
4. Adopt the attached 2022 Audit Compliance Report as required, prior to submission to the Department of Local Government, Sport and Cultural Industries.
5. Receive the update as provided in Attachment 1 in relation to the progress made towards the Regulation 17 Action Plan.
6. Receive the update as provided in Attachment 1 in relation to the progress made towards the Financial Management Systems Review Action Plan.
7. Receive the update as provided in Attachment 1 in relation to the Progress Towards the ICT Strategy Plan.

CARRIED 8/0



Shire of Northam
Heritage, Commerce and Lifestyle

Shire of Northam

Minutes

Audit & Risk Management

Committee Meeting

23 February 2023

Audit & Risk Management Committee Meeting Minutes
23 February 2023



DISCLAIMER

In certain circumstances members of the public are not entitled to inspect material, which in the opinion of the Chief Executive Officer is confidential, and relates to a meeting or a part of a meeting that is likely to be closed to members of the public.

No responsibility whatsoever is implied or accepted by the Shire of Northam for any act, omission, statement or intimation occurring during Council or Committee meetings.

The Shire of Northam disclaims any liability for any loss whatsoever and howsoever caused arising out of reliance by any person or legal entity on any such act, omission or statement of intimation occurring during Council or Committee meetings.

Any person or legal entity who acts or fails to act in reliance upon any statement, act or omission made in a Council or Committee meeting does so at that person's or legal entity's own risk.

In particular and without derogating in any way from the broad disclaimer above, in any discussion regarding any planning application or application for a licence, any statement or intimation of approval made by any member or Officer of the Shire of Northam during the course of any meeting is not intended to be and is not taken as notice of approval from the Shire of Northam.

The Shire of Northam advises that anyone who has any application lodged with the Shire of Northam must obtain and should only rely on WRITTEN CONFIRMATION of the outcome of the application and any conditions attaching to the decision made by the Shire of Northam in respect of the application.

The Shire of Northam advises that any plans or documents contained within this agenda may be subject to copyright law provisions (*Copyright Act 1968*, as amended) and that the express permission of the copyright owner(s) should be sought prior to their reproduction. It should be noted that copyright owners are entitled to take legal action against any persons who infringe their copyright. A reproduction of material that is protected by copyright may represent a copyright infringement.

Audit & Risk Management Committee Meeting Minutes
23 February 2023



Contents

1.	DECLARATION OF OPENING.....	4
2.	ACKNOWLEDGEMENT TO COUNTRY.....	4
3.	ATTENDANCE.....	4
3.1	APOLOGIES.....	4
3.2	APPROVED LEAVE OF ABSENCE.....	4
3.3	ABSENT.....	4
4.	DISCLOSURE OF INTERESTS.....	4
5.	CONFIRMATION OF MINUTES	5
5.1	COMMITTEE MEETING HELD ON 16 DECEMBER 2022.....	5
6.	COMMITTEE REPORTS.....	6
6.1	MONTHLY COMPLIANCE REPORT	6
6.2	RISK REGISTER	19
6.3	RISK REGISTER REVIEW	23
6.4	COMPLIANCE AUDIT RETURN	23
6.5	PROGRESS TOWARDS THE REGULATION 17 REVIEW	47
6.6	PROGRESS TOWARDS THE FINANCIAL MANAGEMENT REVIEW	52
6.7	PROGRESS TOWARDS THE ICT STRATEGY PLAN.....	57
7.	URGENT BUSINESS APPROVED BY DECISION.....	62
8.	DATE OF NEXT MEETING.....	62
9.	DECLARATION OF CLOSURE	62

Audit & Risk Management Committee Meeting Minutes
23 February 2023



1. DECLARATION OF OPENING

The Shire President, Cr C R Antonio, declared the meeting open at 5.03pm.

2. ACKNOWLEDGEMENT TO COUNTRY

The Shire of Northam would like to acknowledge the Traditional Owners of the land on which we meet, the Ballardong and Whadjuk people of the Nyoongar nation and pay our respects to Elders, past, present and emerging.

3. ATTENDANCE

Committee:

Shire President
Councillors

Cr C R Antonio
Cr A J Mencshelyi
Cr H J Appleton

Staff:

Executive Manager Corporate Services
Governance Coordinator
Governance Officer

C J Young
A C McCall
T P Van Beek

3.1 APOLOGIES

Committee:

Deputy President

Cr M P Ryan

Staff:

Chief Executive Officer

J B Whiteaker

3.2 APPROVED LEAVE OF ABSENCE

Nil.

3.3 ABSENT

Nil.

4. DISCLOSURE OF INTERESTS

Nil.

Members should fill in Disclosure of Interest forms for items in which they have a financial, proximity or impartiality interest and forward these to the Presiding Member before the meeting commences.

*As defined in section 5.60A of the Local Government Act 1995, a **financial interest** occurs where a Councillor / Committee Member, or a person with whom the Councillor / Committee Member is closely associated, has a direct*

Audit & Risk Management Committee Meeting Minutes
23 February 2023



or indirect financial interest in the matter. That is, the person stands to make a financial gain or loss from the decision, either now or at some time in the future.

As defined in section 5.61 of the Local Government Act 1995, an **indirect financial** interest includes a reference to a financial relationship between that person and another person who requires a Local Government decision in relation to the matter.

As defined in section 5.60B of the Local Government Act 1995, a person has a **proximity interest** in a matter if the matter concerns a proposed change to a planning scheme affecting land that adjoins the person's land; or a proposed change to the zoning or use of land that adjoins the person's land; or a proposed development (as defined in section 5.63(5)) of land that adjoins the person's land.

As defined in 34C of the Local Government (Administration) Regulations 1996, an **impartiality interest** means an interest that could, or could reasonably be perceived to, adversely affect the impartiality of the person having the interest and includes an interest arising from kinship, friendship or membership of an association.

5. CONFIRMATION OF MINUTES

5.1 COMMITTEE MEETING HELD ON 16 DECEMBER 2022

RECOMMENDATION / COMMITTEE DECISION

Minute No: AU.241

Moved: Cr Appleton

Seconded: Cr Mencshelyi

That the minutes of the Audit & Risk Management Committee meeting held on 16 December 2022 be confirmed as a true and correct record of that meeting.

CARRIED 3/0

Audit & Risk Management Committee Meeting Minutes
23 February 2023



6. COMMITTEE REPORTS

6.1 MONTHLY COMPLIANCE REPORT

File Reference:	1.6.1.6
Reporting Officer:	Alysha McCall, Acting Governance Coordinator
Responsible Officer:	Jason Whiteaker, Chief Executive Officer
Officer Declaration of Interest:	Nil
Voting Requirement:	Simple Majority
Press release to be issued:	No

BRIEF

This report provides Council with an overview of the Shire's monthly compliance activities.

ATTACHMENTS

Attachment 1: Compliance Calendar and Creditors Checklist

A. BACKGROUND / DETAILS

Under the Local Government (Audit) Regulations 1996, a Local Government is required to carry out a Compliance Audit for the period 1 January to 31 December of each year. To ensure compliance and to strengthen the auditing in key areas on a more regular basis, the Shire has implemented a monthly Compliance Calendar where specific activities and statutory requirements are audited internally.

B. CONSIDERATIONS

B.1 Strategic Community / Corporate Business Plan

Performance Area: Performance.

Outcome 12: Excellence in organisational performance and customer service.

Objective 12.1: Maintain a high standard of corporate governance and financial management.

Priority Action 12.1.4: Provide internal auditing capabilities (including providing additional human or financial resources) and publish findings annually.

B.2 Financial / Resource Implications

N/A.

Audit & Risk Management Committee Meeting Minutes
23 February 2023



B.3 Legislative Compliance

There is no legislative requirement to maintain a Compliance Calendar, however it is considered best practice and covers the following Regulations:

- *Local Government (Functions and General) Regulations 1996;*
- *Local Government (Administration) Regulations 1996;*
- *Local Government (Elections) Regulations 1997;*
- *Local Government (Audit) Regulations 1996;*
- *Local Government (Rules of Conduct) Regulations 2007.*

B.4 Policy Implications

Nil.

B.5 Stakeholder Engagement / Consultation

Nil.

B.6 Risk Implications

Risk Category	Description	Rating (consequence x likelihood)	Mitigation Action
Financial	Ability to misuse funds.	Rare (2)x Medium (3) = Low (3)	Compliance calendar assists to ensure compliance
Health Safety	N/A		
Reputation	N/A		
Service Interruption	N/A		
Compliance	Staff not following legislative requirements	Rare (2)x Medium (3) = Low (3)	Compliance calendar assists to ensure compliance
Property	N/A		
Environment	N/A		

B.7 Natural Environment Considerations

N/A

C. OFFICER'S COMMENT

The monthly Compliance Calendar is an effective tool to assist in populating the Annual Compliance Audit Return (CAR) and enhances the Shire's ability to identify and manage issues which may arise during the year, in a timely manner.

Included in the Compliance Calendar is a random audit of Creditors to ensure compliance with the Shire's purchasing policy and the requirements of the *Local Government Act 1995*



2022/23 Compliance Calendar

Month	Item	% Compliance	Non-Compliance
December	Internal Compliance Audit	97%	One (1) non-compliance relating to the Delegated Authority Register not being updated for a multiple cat application.
	Random Creditor Check	90%	EFT for Pavement Management Services is non-compliant due to only 1 quote being obtained with no justification attached to the purchase order. 3 quotes are required when purchases of this value are made.
January	Internal Compliance Audit	94%	Non-compliances relate to: RFT 01 of 2023 - Cemetery Grave Digging lists a closing date of 8 March in Vendor Panel however the register lists this as 8 February 2023. No extension of time has been recorded. BCITF levy not being paid by the required date. BSL not being paid by the required date. Information being provided to the Valuer General by the due date.
	Random Creditor Check	100%	Nil.

RECOMMENDATION / COMMITTEE DECISION

Minute No: AU.242

Moved: Cr Mencshelyi

Seconded: Cr Appleton

That Council receive the update as provided in the monthly Compliance Calendar Report.

CARRIED 3/0

Audit & Risk Management Committee Meeting Minutes
23 February 2023



Clarification was sought in relation to:

- Why the non-compliance for the multiple cat applications in the Delegated Authority Register occurred?
The Governance Coordinator advised that the relevant staff had not been updating the Delegated Authority Register. Since identifying this issue it has been communicated and rectified by staff.
- How did the non-compliance occur in relation to the tender for Pavement Management Services?
The Governance Coordinator advised that as it was a tender the number of quotes received depended on the number of companies who applied for tender. In this instance only one quote was received and a file not should have been completed to justify this, which did not occur. The policy in relation to tenders and quotations will be reviewed in the coming months.
- Did the Community Emergency Services Manager complete their Primary Return in the allotted timeframe?
The Governance Coordinator confirmed that they did.

UNCONFIRMED



Audit & Risk Management Committee Meeting Minutes
23 February 2023

December 2022 – Creditor Check

EFT #	Creditor	Invoice Amount	Invoice Date	Order #	Order Amount	Purchase Order Written	Signing Officer Name	Purchasing Procedure Checklist attached and completed correctly	Date of order prior to date of invoice
EFT45785	MORRIS PEST & WEED CONTROL	\$ 3,615.70	16/11/2022	68473	\$ 3,615.70	10/10/2022	J JURMANN	YES	YES
EFT45812	VENDOR PANEL	\$ 6,836.02	17/11/2022	68442	\$ 6,836.02	6/10/2022	K HOPKINS	YES	YES
EFT45819	AVON WASTE	\$ 4,092.00	21/11/2022	68665	\$ 4,092.00	21/10/2022	J JURMANN	YES	YES
EFT45834	KENNARDS HIRE PTY LTD	\$ 2,550.00	28/11/2022	68949	\$ 5,610.00	10/11/2022	S LEOTTA	YES	YES
EFT45883	BLACKWELL PLUMBING & GAS PTY LTD	\$ 2,398.00	7/12/2022	68925	\$ 2,398.00	9/11/2022	D EMERY	YES	YES
EFT45887	BUNNINGS BUILDING SUPPLIES P/L	\$ 2,062.14	22/11/2022	69013	\$ 2,062.14	16/11/2022	I KEILY	YES	YES
EFT45895	COMBINED TYRES PTY LTD	\$ 1,540.00	31/08/2022	67697	\$ 1,540.00	15/08/2022	K HOPKINS	YES	YES
EFT45901	DCM CARPENTRY & MAINTENANCE	\$ 3,135.00	11/12/2022	69236	\$ 3,135.00	2/12/2022	D EMERY	YES	YES
EFT45911	G.S. BEVERIDGE & L.P.NOTTLE	\$ 7,831.00	1/12/2022	66812	\$ 7,831.00	15/06/2022	K HOPKINS	YES	YES
EFT45939	PAVEMENT MANAGEMENT SERVICES PTY LTD	\$ 85,898.59	29/04/2022	63268	\$ 85,898.59	25/08/2021	C KLEYNHANS	NO	YES



Audit & Risk Management Committee Meeting Minutes
23 February 2023

January 2023 – Creditor Check

EFT #	Creditor	Invoice Amount	Invoice Date	Order #	Order Amount	Purchase Order Written	Signing Officer Name	Purchasing Procedure Checklist attached and completed correctly	Date of order prior to date of invoice
EFT46054	ADVANCED TRAFFIC MANAGEMENT (WA) PTY LTD	\$2,853.13	23/12/2022	69482	\$2,853.13	23/12/2022	S LEOTTA	YES	YES
EFT46065	CCD-ALLIANCE	\$30,204.90	16/08/2022	65156	\$33,561.00	20/01/2022	C YOUNG	YES	YES
EFT46074	DRACO AIR PTY LTD	\$242.00	19/12/2022	69438	\$242.00	16/12/2022	S MOORHEAD	YES	YES
EFT46100	POOLSHOP ONLINE PTY LTD	\$1,715.00	12/12/2022	69048	\$1,715.00	17/11/2022	D JUPP	YES	YES
EFT46115	WCP CIVIL PTY LTD	\$209,029.18	30/11/2022	65826	\$601,400.27	15/03/2022	J WHITEAKER	YES	YES
EFT46137	AVON WASTE	\$40,567.16	16/12/2022	67063	\$990,390.18	1/07/2022	J WHITEAKER	YES	YES
EFT46156	FRONTLINE FIRE & RESCUE EQUIPMENT	\$10,309.20	25/11/2022	69317	\$10,309.20	8/12/2022	J JURMANN	YES	YES
EFT46226	PIZZA JOE'S WOODFIRED PIZZA	\$2,100.00	13/01/2023	69595	\$2,100.00	10/01/2023	I KIELY	YES	YES
EFT46263	DCM CARPENTRY & MAINTENANCE	\$110.00	8/01/2023	69478	\$110.00	22/12/2022	C JUPP	YES	YES
EFT46297	SOUTHERN CROSS AUSTEREO PTY LTD	\$55.00	31/12/2022	68198	\$16,077.60	16/09/2022	V WILLIAMS	YES	YES

Audit & Risk Management Committee Meeting Minutes
23 February 2023



December 2022 – Compliance Calendar

SOURCE	Section	PROCESS OWNER	ACTIVITY DESCRIPTION	COMPLIANCE ACCOUNTABILITY	SCHEDULE	COMMENTS
Local Government Act 1995	S3.59 - Commercial Enterprises	CEO	Have SoN entered into any major trading undertakings, if so has section 3.59 been complied with		Monthly	No.
Local Government Act 1995	S5.16	CEO	Is the delegations register current (ie not more than 12 months old)		Annually -June	Yes.
Local Government Act 1995	S5.67	CEO	Where an elected member disclosed a financial interest, did they leave the meeting and not participate in discussion or decision making on the item		Monthly	Yes. Cr Tinetti declared an interest and left the meeting.
Local Government Act 1995	S5.65 & s5.73	CEO	Were all known elected member and staff disclosures of impartiality made at the Council meeting		Monthly	Yes.
Local Government Act 1995	S5.73 & S103	CEO	Were ALL disclosures recorded in the minutes		Monthly	Yes.
Local Government Act 1995	S5.75	CEO	Have primary returns been lodged within 3 months of elected member start		Annually - January	Not applicable.
Local Government Act 1995	S5.76	CEO	Have all new 'designated' employees completed their primary returns within 3 months of commencement		Monthly	Francesca Lefante due by 12 January 2023. Alex Espey return is due on 8 February 2023. Received Sean Cope's return.
Local Government Act 1995	S5.88	CEO	Is the register of financial interests up to date		Monthly	Yes.
Local Government Act 1995	S5.89	CEO	Have all resigned members and staff returns been removed from the financial interest register		Monthly	Yes. Cr Paul Curtis removed.
Local Government Act 1995	S103	CEO	Is the gift register up to date and on the Council website		Monthly	Yes. Nil declared.
Local Government Act 1995	S3.58 - Disposal of Property	CEO	Did the Council dispose of any property in the month, and if so was s3.58 complied with		Monthly	Yes. Portion of Lot 200 Minson Ave & Portion of Lot 202 Fitzgerald St.
Local Government Act 1995	S5.121 - Minor Breach	EMCS	Has the complaints officer maintained the complaints of a minor breach register and is the online register up to date.		Monthly	Yes. No complaints received.
Local Government Act 1995	S3.57 & F/G Reg 11	EMCS	Have tenders been called for all goods or services in excess of \$250k		Monthly	Yes.
Local Government Act 1995	S3.57 & F/G Reg 14	EMCS	Was state wide public notice given for all tenders		Monthly	Not applicable.
Local Government Act 1995	F/G Reg 16	EMCS	Receiving and opening Tenders completed by two persons, details of tenders to be immediately recorded		Monthly	Yes. Tender 05/2022 opened.
Local Government Act 1995	F/G Reg 18	EMCS	Rejecting and accepting Tenders		Monthly	Nil accepted / rejected.
Local Government Act 1995	F/G Reg 18 (1)	EMCS	Tender to be submitted before close of Tender and submitted to the Shire office		Monthly	Yes.
Local Government Act 1995	F/G Reg 18 (4)	EMCS	Written evaluation of each Tenderer's criteria		Monthly	Yes.
Local Government Act 1995	F/G Reg 17	EMCS	Tender Register to be maintained and available for inspection		Monthly	Yes.
Local Government Act 1995	F/G Reg 19	EMCS	Tenderers to be notified of outcome		Monthly	Not applicable.
Local Government Act 1995	F/G Reg 24AD (2)	EMCS	Statewide Public Notice of the invitation to apply to join a pre-qualified panel		Monthly	Not applicable.
Local Government Act 1995	F/G Reg 24AD (4)	EMCS	Notice to include brief description of goods and services to be supplied by pre-qualified panel		Monthly	Not applicable.
Local Government Act 1995		EMCS	Annual report accepted		31-Dec	Yes.
Local Government Act 1995		Governance	Review meeting attendance		Monthly	Yes.
Local Government Act 1995	s.5.103, s.5.104 Admin.Reg. Part 9 Rules of Conduct Regs.	Governance	Policy Review- Code of Conduct - provide Council report to enable the new council to review and adopt the Code of Conduct		Bi Annually	Review underway.



Audit & Risk Management Committee Meeting Minutes
23 February 2023

	Delegation - B02	EMDS	Buildings - Grant or Refuse Demolition Permit - register completed?	Monthly	Yes. One (1) granted and added to the Delegated Authority Register.
	Delegation - E01	EMES	Temporary Closure of Thoroughfares to vehicles	Monthly	Yes. One (1) closure.
	Delegation - E04	EMES	Crossover Approvals	Monthly	Nil determined.
	Delegation - F02	EMCS	Disposal of Council property	Monthly	Nil.
	Delegation - F04	EMCS	Inviting Tenders	Monthly	Nil.
	Delegation - F05	CEO	Waving of fees	Monthly	Yes.
	Delegation - F06	CEO	Disposing of Property by Lease or Licence	Monthly	Yes. Four (4) disposals, refer to Delegated Authority Register.
	Delegation - R01	EMDS	Approval to keep more than one cat or dog	Monthly	Multiple cat applications not recorded on the register.
		EMCS	Interim Audit	Annually	Carried out from the 25 April 2022 to 29 April 2022.
		EMCS	Accounts presented to Council	Monthly	Yes.
		EMCS	Financial Report to Council	Monthly	Yes.
Local Government Act 1995	FMR r. 51		Annual Report to DLGSC	by 30 Dec	Yes. Sent 16 December 2022.
Reporting	Building Services (Complaint Resolution and Administration) Regulations 2011	Building	Building Services Levy - Payment due by 14th day after the end of the month	Monthly	Yes.
Reporting	Building and Construction Industry Training Fund and Levy Collection Regulations 1991	Building	Building Construction Training Fund Levy - Payment due by 10th day after the end of the month	Monthly	Yes.
	Completed by:	Alysha McCall			
	Position:	Acting Governance Coordinator			
	Date:	17/01/2023			
	Signed:				



Audit & Risk Management Committee Meeting Minutes
23 February 2023

January 2023 – Compliance Calendar

Compliance Area	Compliance Action	Compliance Requirement	Section / Ref	Compliance Frequency	Responsible Officer Position Title	January	January Comments
Code of Conduct	Has the CEO published an up-to-date version of the code of conduct for employees on the local government's website	Local Government Act 1995	s5.104(7)	Monthly	Governance Officer	Yes	
Code of Conduct	Has the CEO prepared and implemented a code of conduct to be observed by employees of the local government in accordance with section 5.51A(1) of the Local Government Act 1995	Local Government Act 1995	s5.51A(1) & (3)	Monthly	Governance Coordinator	Yes	
Commercial Enterprises by Local Governments	Has the local government prepared a business plan for each major trading undertaking that was not exempt?	Local Government Act 1995	s3.59(2)(a) F&G Regs 7,9,10	Monthly	CEO / Executive Managers	Not applicable	
Commercial Enterprises by Local Governments	Has the local government prepared a business plan for each major land transaction that was not exempt	Local Government Act 1995	s3.59(2)(b) F&G Regs 7,8A, 8, 10	Monthly	CEO / Executive Managers	Not applicable	
Commercial Enterprises by Local Governments	Has the local government prepared a business plan before entering into each land transaction that was preparatory to entry into a major land transaction	Local Government Act 1995	s3.59(2)(c) F&G Regs 7,8A, 8,10	Monthly	CEO / Executive Managers	Not applicable	
Commercial Enterprises by Local Governments	Has the local government complied with public notice and publishing requirements for each proposal to commence a major trading undertaking or enter into a major land transaction or a land transaction that is preparatory to a major land transaction	Local Government Act 1995	s3.59(4)	Monthly	CEO / Executive Managers	Not applicable	
Commercial Enterprises by Local Governments	Did the council resolve to proceed with each major land transaction or trading undertaking by absolute majority	Local Government Act 1995	s3.59(5)	Monthly	CEO / Executive Managers	Not applicable	
Delegation of Power / Duty	Were all decisions by the council to amend or revoke a delegation made by absolute majority	Local Government Act 1995	s5.16(3)(b) & s5.45(1)(b)	Monthly	Governance Coordinator	Not applicable	
Delegation of Power / Duty	Did all persons exercising a delegated power or duty under the Act keep, on all occasions, a written record in accordance with Local Government (Administration) Regulations 1996, Regulation 19 Was the Delegated Authority Register updated?	Local Government Act 1995	s5.46(3) Admin Reg 19	Monthly	Governance Coordinator	Yes	
Disclosure of Interest	Where a council member disclosed an interest in a matter and did not have participation approval under sections 5.68 or 5.69 of the Local Government Act 1995, did the council member ensure that they did not remain present to participate in discussion or decision making relating to the matter	Local Government Act 1995	s5.67	Monthly	Governance Coordinator	Yes	
Disclosure of Interest	Were all decisions regarding participation approval, including the extent of participation allowed and, where relevant, the information required the Local Government (Administration) Regulations 1996 regulation 21A, recorded in the minutes of the relevant council or committee meeting	Local Government Act 1995	s5.68(2) & s5.69(5) Admin Reg 21A	Monthly	Governance Officer	Not applicable	
Disclosure of Interest	Were disclosures under section sections 5.65, 5.70 or 5.71A(3) of the Local Government Act 1995 recorded in the minutes of the meeting at which the disclosures were made	Local Government Act 1995	s5.73	Monthly	Governance Officer	Yes	
Disclosure of Interest	Where an employee had an interest in any matter in respect of which the employee provided advice or a report directly to council or a committee, did that person disclose the nature and extent of that interest when giving the advice or report	Local Government Act 1995	s5.70(2) & (3)	Monthly	Governance Coordinator	Yes	
Disclosure of Interest	Where council applied to the Minister to allow the CEO to provide advice or a report to which a disclosure under s5.71A(1) of the Local Government Act 1995 relates, did the application include details of the nature of the interest disclosed and any other information required by the Minister for the purposes of the application	Local Government Act 1995	s5.71A & s5.71B(5)	Monthly	Governance Coordinator	Not applicable	
Disclosure of Interest	Was any decision made by the Minister under subsection 5.71B(6) of the Local Government Act 1995 recorded in the minutes of the council meeting at which the decision was considered	Local Government Act 1995	s5.71B(6) & s5.71B(7)	Monthly	Governance Officer	Not applicable	



Audit & Risk Management Committee Meeting Minutes
23 February 2023

Compliance Area	Compliance Action	Compliance Requirement	Section / Ref	Compliance Frequency	Responsible Officer Position Title	January	January Comments
Disposal of Property	Where the local government disposed of property other than by public auction or tender, did it dispose of the property in accordance with section 3.58(3) of the Local Government Act 1995 (unless section 3.58(5) applies)	Local Government Act 1995	s3.58(3)	Monthly	Governance Coordinator	Not applicable	
Disposal of Property	Where the local government disposed of property under section 3.58(3) of the Local Government Act 1995, did it provide details, as prescribed by section 3.58(4) of the Act, in the required local public notice for each disposal of property	Local Government Act 1995	s3.58(4)	Monthly	Governance Coordinator	Not applicable	
Finance	Was a statement of financial activity reporting on the revenue and expenditure as set out in the annual budget under FM.Reg.22(1)(d) presented at an Ordinary Council meeting within 2-months after the end of the month to which the statement relates.	Local Government Act 1995	s.6.4 FM.Reg.34	Monthly	Senior Accountant	Yes	
Gifts	Did the CEO keep a register of gifts which contained a record of disclosures made under sections 5.87A and 5.87B of the Local Government Act 1995, in the form prescribed in the Local Government (Administration) Regulations 1996, regulation 28A	Local Government Act 1995	s5.89A(1), (2) & (3) Admin Reg 28A	Monthly	Governance Officer	Yes	
Gifts	Did the CEO publish an up-to-date version of the gift register on the local government's website	Local Government Act 1995	s5.89A(5) & (5A)	Monthly	Governance Officer	Yes	
Gifts	When people cease to be a person who is required to make a disclosure under section 5.87A or 5.87B of the Local Government Act 1995, did the CEO remove from the register all records relating to those people	Local Government Act 1995	s5.89A(6)	Monthly	Governance Officer	Yes	
Gifts	Have copies of all records removed from the register under section 5.89A(6) Local Government Act 1995 been kept for a period of at least five years after the person ceases to be a person required to make a disclosure	Local Government Act 1995	s5.89A(7)	Monthly	Governance Officer	Yes	
Gifts	Where a disclosure was made under sections 5.87A or 5.87B of the Local Government Act 1995, were the disclosures made within 10 days after receipt of the gift? Did the disclosure include the information required by section 5.87C of the Act	Local Government Act 1995	s5.87C	Monthly	Governance Officer	Not applicable	
Local Government Employees	Were all CEO and/or senior employee vacancies advertised in accordance with Local Government (Administration) Regulations 1996, regulation 18A	Local Government Act 1995	s5.36(4) & s5.37(3) Admin Reg 18A	Monthly	People & Culture Coordinator	Not applicable	
Local Government Employees	Was all information provided in applications for the position of CEO true and accurate	Local Government Act 1995	Admin Reg 18E	Monthly	People & Culture Coordinator	Not applicable	
Local Government Employees	Was the remuneration and other benefits paid to a CEO on appointment the same remuneration and benefits advertised for the position under section 5.36(4) of the Local Government Act 1995	Local Government Act 1995	Admin Reg 18F	Monthly	People & Culture Coordinator	Not applicable	
Local Government Employees	Did the CEO inform council of each proposal to employ or dismiss senior employee	Local Government Act 1995	s5.37(2)	Monthly	People & Culture Coordinator	Not applicable	
Local Government Employees	Where council rejected a CEO's recommendation to employ or dismiss a senior employee, did it inform the CEO of the reasons for doing so	Local Government Act 1995	s5.37(2)	Monthly	People & Culture Coordinator	Not applicable	
Official Conduct	Has the local government designated an employee to be its complaints officer	Local Government Act 1995	s5.120	Monthly	Executive Manager Corporate Services	Yes	
Official Conduct	Has the complaints officer for the local government maintained a register of complaints which records all complaints that resulted in a finding under section 5.110(2)(a) of the Local Government Act 1995	Local Government Act 1995	s5.121(1) & (2)	Monthly	Executive Manager Corporate Services	Yes	
Official Conduct	Does the complaints register include all information required by section 5.121(2) of the Local Government Act 1995	Local Government Act 1995	s5.121(2)	Monthly	Executive Manager Corporate Services	Yes	
Official Conduct	Has the CEO published an up-to-date version of the register of the complaints on the local government's official website	Local Government Act 1995	s5.121(3)	Monthly	Governance Officer	Yes	



Audit & Risk Management Committee Meeting Minutes
23 February 2023

Compliance Area	Compliance Action	Compliance Requirement	Section / Ref	Compliance Frequency	Responsible Officer Position Title	January	January Comments
Other	Was the below information provided to the Valuer General by the 14th day of each month: • building licenses issued • building license works completed • registered plans and amendments under the Strata Titles Act 1985	Valuation of Land Act 1978	s.37	Monthly	Development Services Support Officer	No	
Other	Building Services Levy - Payment due by 14th day after the end of the month	Building Services (Complaint Resolution and Administration) Regulations 2011	s.94	Monthly	Development Services Support Officer	No	
Other	Building Construction Training Fund Levy - Payment due by 10th day after the end of the month	Building and Construction Industry Training Fund and Levy Collection Act 1990	N/A	Monthly	Development Services Support Officer	No	
Other	Did the CEO publish information on the local government's website in accordance with sections 5.96A(1), (2), (3), and (4) of the Local Government Act 1995	Local Government Act 1995	s5.96A(1), (2), (3) & (4)	Monthly	Governance Officer	Yes	
Primary / Annual Returns	Was a primary return in the prescribed form lodged by all relevant persons within three months of their start day	Local Government Act 1995	s5.75 Admin Reg 22, Form 2	Monthly	Governance Officer	Not applicable	
Primary / Annual Returns	On receipt of a primary or annual return, did the CEO, or the mayor/president, give written acknowledgment of having received the return	Local Government Act 1995	s5.77	Monthly	Governance Officer	Not applicable	
Primary / Annual Returns	Did the CEO keep a register of financial interests which contained the returns lodged under sections 5.75 and 5.76 of the Local Government Act 1995	Local Government Act 1995	s5.88(1) & (2)(a)	Monthly	Governance Officer	Yes	
Primary / Annual Returns	Did the CEO keep a register of financial interests which contained a record of disclosures made under sections 5.65, 5.70, 5.71 and 5.71A of the Local Government Act 1995, in the form prescribed in the Local Government (Administration) Regulations 1996, regulation 28	Local Government Act 1995	s5.88(1) & (2)(b) Admin Reg 28	Monthly	Governance Officer	Yes	
Primary / Annual Returns	When a person ceased to be a person required to lodge a return under sections 5.75 and 5.76 of the Local Government Act 1995, did the CEO remove from the register all returns relating to that person	Local Government Act 1995	s5.88(3)	Monthly	Governance Officer	Yes	
Primary / Annual Returns	Have all returns removed from the register in accordance with section 5.88(3) of the Local Government Act 1995 been kept for a period of at least five years after the person who lodged the return(s) ceased to be a person required to lodge a return	Local Government Act 1995	s5.88(4)	Monthly	Governance Officer	Yes	
Tenders for Providing Goods & Services	Did the local government comply with its current purchasing policy, adopted under the Local Government (Functions and General) Regulations 1996, regulations 11A(1) and (3) in relation to the supply of goods or services where the consideration under the contract was, or was expected to be, \$250,000 or less or worth \$250,000 or less	Local Government Act 1995	F&G Reg 11A(1) & (3)	Monthly	Procurement Coordinator	Yes	
Tenders for Providing Goods & Services	Subject to Local Government (Functions and General) Regulations 1996, regulation 11(2), did the local government invite tenders for all contracts for the supply of goods or services where the consideration under the contract was, or was expected to be, worth more than the consideration stated in regulation 11(1) of the Regulations	Local Government Act 1995	s3.57 F&G Reg 11	Monthly	Procurement Coordinator	Yes	
Tenders for Providing Goods & Services	When regulations 11(1), 12(2) or 13 of the Local Government (Functions and General) Regulations 1996, required tenders to be publicly invited, did the local government invite tenders via Statewide public notice in accordance with Regulation 14(3) and (4)	Local Government Act 1995	F&G Regs 11(1), 12(2), 13, & 14(1), (3), and (4)	Monthly	Procurement Coordinator	Yes	
Tenders for Providing Goods & Services	Did the local government comply with Local Government (Functions and General) Regulations 1996, Regulation 12 when deciding to enter into multiple contracts rather than a single contract	Local Government Act 1995	F&G Reg 12	Monthly	Procurement Coordinator	Not applicable	



Audit & Risk Management Committee Meeting Minutes
23 February 2023

Compliance Area	Compliance Action	Compliance Requirement	Section / Ref	Compliance Frequency	Responsible Officer Position Title	January	January Comments
Tenders for Providing Goods & Services	If the local government sought to vary the information supplied to tenderers, was every reasonable step taken to give each person who sought copies of the tender documents or each acceptable tenderer notice of the variation	Local Government Act 1995	F&G Reg 14(5)	Monthly	Procurement Coordinator	Yes	
Tenders for Providing Goods & Services	Did the local government's procedure for receiving and opening tenders comply with the requirements of Local Government (Functions and General) Regulations 1996, Regulation 15 and 16	Local Government Act 1995	F&G Regs 15 & 16	Monthly	Procurement Coordinator	Not applicable	
Tenders for Providing Goods & Services	Did the information recorded in the local government's tender register comply with the requirements of the Local Government (Functions and General) Regulations 1996, Regulation 17 and did the CEO make the tenders register available for public inspection and publish it on the local government's official website	Local Government Act 1995	F&G Reg 17	Monthly	Procurement Coordinator	No	RFT 01 of 2023 - Cemetery Grave Digging lists a closing date of 8 March in Vendor Panel however the register lists this as 8 February 2023. No extension of time has been recorded.
Tenders for Providing Goods & Services	Did the local government reject any tenders that were not submitted at the place, and within the time, specified in the invitation to tender	Local Government Act 1995	F&G Reg 18(1)	Monthly	Procurement Coordinator	Not applicable	
Tenders for Providing Goods & Services	Were all tenders that were not rejected assessed by the local government via a written evaluation of the extent to which each tender satisfies the criteria for deciding which tender to accept	Local Government Act 1995	F&G Reg 18(4)	Monthly	Procurement Coordinator	Not applicable	
Tenders for Providing Goods & Services	Did the CEO give each tenderer written notice containing particulars of the successful tender or advising that no tender was accepted	Local Government Act 1995	F&G Reg 19	Monthly	Procurement Coordinator	Not applicable	
Tenders for Providing Goods & Services	Did the local government's advertising and expression of interest processes comply with the requirements of the Local Government (Functions and General) Regulations 1996, Regulations 21 and 22	Local Government Act 1995	F&G Regs 21 & 22	Monthly	Procurement Coordinator	Not applicable	
Tenders for Providing Goods & Services	Did the local government reject any expressions of interest that were not submitted at the place, and within the time, specified in the notice or that failed to comply with any other requirement specified in the notice	Local Government Act 1995	F&G Reg 23(1) & (2)	Monthly	Procurement Coordinator	Not applicable	
Tenders for Providing Goods & Services	Were all expressions of interest that were not rejected under the Local Government (Functions and General) Regulations 1996, Regulation 23(1) & (2) assessed by the local government? Did the CEO list each person as an acceptable tenderer	Local Government Act 1995	F&G Reg 23(3) & (4)	Monthly	Procurement Coordinator	Not applicable	
Tenders for Providing Goods & Services	Did the CEO give each person who submitted an expression of interest a notice in writing of the outcome in accordance with Local Government (Functions and General) Regulations 1996, Regulation 24	Local Government Act 1995	F&G Reg 24	Monthly	Procurement Coordinator	Not applicable	
Tenders for Providing Goods & Services	Did the local government invite applicants for a panel of pre-qualified suppliers via Statewide public notice in accordance with Local Government (Functions and General) Regulations 1996, Regulations 24AD(4) and 24AE	Local Government Act 1995	F&G Regs 24AD(2) & (4) and 24AE	Monthly	Procurement Coordinator	Not applicable	
Tenders for Providing Goods & Services	If the local government sought to vary the information supplied to the panel, was every reasonable step taken to give each person who sought detailed information about the proposed panel or each person who submitted an application notice of the variation	Local Government Act 1995	F&G Reg 24AD(6)	Monthly	Procurement Coordinator	Not applicable	
Tenders for Providing Goods & Services	Did the local government's procedure for receiving and opening applications to join a panel of pre-qualified suppliers comply with the requirements of Local Government (Functions and General) Regulations 1996, Regulation 16, as if the reference in that regulation to a tender were a reference to a pre-qualified supplier panel application	Local Government Act 1995	F&G Reg 24AF	Monthly	Procurement Coordinator	Not applicable	
Tenders for Providing Goods & Services	Did the information recorded in the local government's tender register about panels of pre-qualified suppliers comply with the requirements of Local Government (Functions and General) Regulations 1996, Regulation 24AG	Local Government Act 1995	F&G Reg 24AG	Monthly	Procurement Coordinator	Not applicable	



Audit & Risk Management Committee Meeting Minutes
23 February 2023

Compliance Area	Compliance Action	Compliance Requirement	Section / Ref	Compliance Frequency	Responsible Officer Position Title	January	January Comments
Tenders for Providing Goods & Services	Did the local government reject any applications to join a panel of pre-qualified suppliers that were not submitted at the place, and within the time, specified in the invitation for applications	Local Government Act 1995	F&G Reg 24AH(1)	Monthly	Procurement Coordinator	Not applicable	
Tenders for Providing Goods & Services	Were all applications that were not rejected assessed by the local government via a written evaluation of the extent to which each application satisfies the criteria for deciding which application to accept	Local Government Act 1995	F&G Reg 24AH(3)	Monthly	Procurement Coordinator	Not applicable	
Tenders for Providing Goods & Services	Did the CEO send each applicant written notice advising them of the outcome of their application	Local Government Act 1995	F&G Reg 24AI	Monthly	Procurement Coordinator	Not applicable	
						Compliance Items	63
						Items Compliant	59
						Items Non-Compliant	4
						Percentage Compliant	94%
						Auditor:	Alysha McCall
						Auditor Signature:	
						Date Completed:	17/02/2023

UNCONFIRMED

Audit & Risk Management Committee Meeting Minutes
23 February 2023



6.2 RISK REGISTER

File Reference:	8.2.7.1
Reporting Officer:	Alysha McCall, Acting Governance Coordinator
Responsible Officer:	Jason Whiteaker, Chief Executive Officer
Officer Declaration of Interest:	Nil.
Voting Requirement:	Simple Majority
Press release to be issued:	No

BRIEF

To provide Council with information pertaining to the organisational risk register.

ATTACHMENTS

Attachment 1: Overdue/Non-compliant Risks.

A. BACKGROUND / DETAILS

The Shire of Northam have an organisational wide risk register which has been developed over a period of time. Council has been advised previously that the management of risk is an area which has been under developed within the Shire of Northam and an area which was receiving a focus to ensure the Elected Council was aware of the identified risks and treatments strategies in place.

To assist in the effective management of risk the Shire of Northam are using the Promapp system, which allows for recording of organisational risks and the tracking of the associated treatment actions.

B. CONSIDERATIONS

B.1 Strategic Community / Corporate Business Plan

Performance Area: Performance.

Outcome 12: Excellence in organisational performance and customer service.

Objective 12.1: Maintain a high standard of corporate governance and financial management.

Action 12.1.4: Provide internal auditing capabilities (including providing additional human or financial resources) and publish findings annually.

Audit & Risk Management Committee Meeting Minutes
23 February 2023



B.2 Financial / Resource Implications

Council allocates \$27,000 per annum for the Promapp system. Promapp is used for process mapping, risk management and OHS management.

B.3 Legislative Compliance

AS/NZS ISO 31000:2009

B.4 Policy Implications

Council has recently endorsed policy G1.11 – Risk Management.

B.5 Stakeholder Engagement / Consultation

Council was involved in the development of the risk management policy and the past endorsement of the risk management plan.

B.6 Risk Implications

Risk Category	Description	Rating (consequence x likelihood)	Mitigation Action
Financial	Nil.	N/A	N/A
Health & Safety	Nil.	N/A	N/A
Reputation	Negative community perception due to lack of adequate risk management practices within the Shire of Northam	Minor(2) x Possible(3) = Moderate(6)	Per recommendation within this report
Service Interruption	Nil.	N/A	N/A
Compliance	Non-compliance of Australian Standards and legislation due to lack of risk management practices.	Minor(2) x Possible(3) = Moderate(6)	Per recommendation within this report
Property	Nil.	N/A	N/A
Environment	Nil.	N/A	N/A

B.7 Natural Environment Considerations

N/A

C. OFFICER'S COMMENT

As part of the risk management policy Council has established two main performance indicators being;

Audit & Risk Management Committee Meeting Minutes
23 February 2023



1. % of high or extreme risks without mitigation / treatment strategies in place.

Currently all high or extreme risks have mitigation/treatment strategies.

2. % of risk mitigation / treatment strategies over due
Currently have 136 risk mitigation/treatment strategies, of which **1 are overdue (which equates to 0.74%)**.

- MC00107 - Ensure asset management plan financial requirements are included in long term financial plan

Comment – Treatment was complete however was a delay in signing off the risk treatment.

At the Audit & Risk Management Committee Meeting held on 2 June 2022, the Chief Executive Officer advised that the entire register would also be provided to give the Council some context on the entire register, so any perceived gaps in the register could be identified. The committee also indicated that it would like to review the entire risk register, breaking it down in small sections at future Audit & Risk Committee meetings.

RECOMMENDATION / COMMITTEE DECISION

Minute No: AU.243

Moved: Cr Appleton

Seconded: Cr Mencshelyi

That Council receives the February 2023 Shire of Northam Risk Register update.

CARRIED 3/0

Audit & Risk Management Committee Meeting Minutes
23 February 2023



RESIDUAL 3.0 LOW <hr/> INHERENT 10.0 R00054	ENGINEERING SERVICES, SERVICE INTERRUPTION PPOSAMP Service Levels Interruption Identify and budget for assets reaching end of life there will likely be service interruptions with delayed replacement timeframes.	TREATMENT MC00106 Review Asset Management plan every two years.	SIGNOFF(S): Keith Boase DUE DATE: 01 Oct 2024 FREQUENCY: The first Day of every 24 months
	OWNER Keith Boase CREATED 02/12/2020 09:37:11 LIKELIHOOD Almost Certain SEVERITY Minor CONTROL EFFECTIVENESS Strong	TREATMENT MC00107 Ensure asset management plan financial requirements are included in long term financial plan	OVERDUE SIGNOFF(S): Keith Boase DUE DATE: 31 Jan 2023 FREQUENCY: The last Day of every 12 months
		TREATMENT MC00108 Ensure asset management plan financial requirements are included in annual budget	SIGNOFF(S): Keith Boase DUE DATE: 01 Jun 2023 FREQUENCY: The first Day of every 12 months

UNCONFIRMED

Audit & Risk Management Committee Meeting Minutes
23 February 2023



6.3 RISK REGISTER REVIEW

This item was not presented during the meeting.

6.4 COMPLIANCE AUDIT RETURN

File Reference:	1.6.1.6
Reporting Officer:	Alysha McCall, Acting Governance Coordinator
Responsible Officer:	Jason Whiteaker, Chief Executive Officer
Officer Declaration of Interest:	Nil
Voting Requirement:	Simple Majority
Press release to be issued:	No

BRIEF

This report is to provide information to assist Council in the adoption of the 2022 Compliance Audit Return (CAR).

ATTACHMENTS

Attachment 1: Compliance Audit Return 2022

A. BACKGROUND / DETAILS

Under the Local Government (Audit) Regulations 1996, a Local Government is required to carry out a Compliance Audit for the period 1 January to 31 December of each year. The certified return should be submitted to the Director General, Department of Local Government and Regional Development by 31 March each year.

The Compliance Audit Return must be:

1. Presented to Council at a meeting of the Council;
2. Be adopted by the Council; and
3. Recorded in the minutes of the meeting at which it is adopted.

In relation to the year 2022 a copy of the return is to be submitted for Councillor's perusal, comment and adoption prior to 31 March 2023. It is necessary for the Shire President and the Chief Executive Officer to sign off the return as a certified copy.

The 2022 Compliance Audit Return has been completed in house, with the CEO and senior staff reviewing and approving the completed return. The compliance review process provides both the CEO and the Council with an

Audit & Risk Management Committee Meeting Minutes
23 February 2023



additional element of accountability through a check on internal management systems, procedures and record keeping and this demonstrates the Shire's emphasis on improving its good governance, compliance, and best practice.

B. CONSIDERATIONS

B.1 Strategic Community / Corporate Business Plan

Performance Area: Performance.

Outcome 12: Excellence in organisational performance and customer service.

Objective 12.1: Maintain a high standard of corporate governance and financial management.

Priority Action 12.1.4: Provide internal auditing capabilities (including providing additional human or financial resources) and publish findings annually.

B.2 Financial / Resource Implications

Nil.

B.3 Legislative Compliance

Local Government Act 1995;

Local Government (Functions and General) Regulations 1996;

Local Government (Administration) Regulations 1996;

Local Government (Elections) Regulations 1997;

Local Government (Audit) Regulations 1996;

Local Government (Rules of Conduct) Regulations 2007.

B.4 Policy Implications

Nil.

B.5 Stakeholder Engagement / Consultation

All senior staff were asked to review the document and make any comments.

B.6 Risk Implications

Risk Category	Description	Rating (likelihood x consequence)	Mitigation Action
Financial	Nil		
Health & Safety	Nil		
Reputation	Any non-compliance could impact staff and members of the community and may give them a poor	Unlikely (2) x Minor (2) = Low (4)	Put processes in place to mitigate non-compliance

Audit & Risk Management Committee Meeting Minutes
23 February 2023



	reflection of dealing with Council.		
Service Interruption	Nil		
Compliance	Non-compliance with the Local Government Act 1995 and subsidiary legislation.	Low (3) x Medium (3) = Moderate (9)	Adopt the Compliance Audit Return by 31 March. Undertake a monthly internal audit.
Property	Nil		
Environment	Nil		

B.7 Natural Environment Considerations

N/A.

C. OFFICER'S COMMENT

Each year the Shire strives to improve the services it provides to stakeholders both internal and external. The 2022 CAR is a decrease from the previous year's compliance of 100%.

This year there were eleven (11) categories with a total of ninety four (94) questions.

TITLE	NUMBER OF QUESTIONS	PERCENTAGE
Commercial Enterprises	5	100%
Delegation of Power/Duty	13	100%
Disclosure of Interests	21	95%
Disposal of Property	2	50%
Elections	3	100%
Finance	7	100%
Integrated Planning & Reporting	3	100%
Local Government Employees	5	100%
Official Conduct	4	100%
Other	9	89%
Tenders for Goods & Services	22	100%

This year there has been 97% compliance in all categories. These non-compliances relate to:

- Ex-Councillor Paul Curtis did not complete his annual return by the required date.
- Two leases were entered into for the Pop Up Shop which did not meet the disposal requirements of the *Local Government Act 1995*. These

Audit & Risk Management Committee Meeting Minutes
23 February 2023



agreements are now issued as licences to ensure compliance with the *Local Government Act 1995*.

- A local law for the Establishment, Maintenance and Equipment of Bush Fire Brigades which was Gazetted on 21 May 1982. Council approved repealing this local law on 12 February 2004 however this was never published in the Gazette. This local law is not listed on the Shire of Northam website which has resulted in a non-compliance. Officers are currently liaising with the Department of Local Government, Sports and Cultural Industries in relation to the most appropriate action to finalise this repeal process.

RECOMMENDATION / COMMITTEE DECISION

Minute No: AU.244

Moved: Cr Mencshelyi

Seconded: Cr Appleton

That Council adopt the attached 2022 Audit Compliance Report as required, prior to submission to the Department of Local Government, Sport and Cultural Industries.

CARRIED 3/0

Clarification was sought in relation to:

- The non-compliance in regards to the Pop-Up Shop.
The Governance Coordinator advised that it was identified that in providing lease agreements to the individuals leasing the Pop-Up Shop we were non-compliant. Since this was identified it has been rectified and we now offer licence agreements to remain compliant.
- A discussion was held regarding councillors and staff providing annual returns, a spreadsheet will be created/distributed to assist councillors to complete their returns.
- How did the non-compliance under 'other' regarding local laws occur?

The Governance Coordinator advised that it was identified that the Local Law for the Establishment, Maintenance and Equipment of Bush Fire Brigades – Gazetted in 1982 was never repealed and was not listed on the Shire of Northam website. This is in the process of being rectified.



Attachment 1 - Compliance Audit Return 2022

Home (/) / Compliance Audit Return (/CAR/) / Compliance Audit Return Form

Compliance Audit Return Form

Start ✓	Details ✓	Commercial Enterprises ✓	Delegation ✓			
Disclosure of Interest ✓	Disposal of Property ✓	Elections ✓	Finance ✓	IPR ✓		
Employees ✓	Conduct ✓	Other ✓	Tenders ✓	Documents ✓	Review	Finalise

Print

Details

Local Government	Year of Return	Status
Northam, Shire of	2022	Draft
Created By		
Alysha McCall		

Commercial Enterprises by Local Governments

1. Has the local government prepared a business plan for each major trading undertaking that was not exempt in 2022? * Add comments

N/A

2. Has the local government prepared a business plan for each major land transaction that was not exempt in 2022? * Add comments

N/A

Audit & Risk Management Committee Meeting Minutes
23 February 2023



3. Has the local government prepared a business plan before entering into each land transaction that was preparatory to entry into a major land transaction in 2022? * Add comments

N/A

—

4. Has the local government complied with public notice and publishing requirements for each proposal to commence a major trading undertaking or enter into a major land transaction or a land transaction that is preparatory to a major land transaction for 2022? * Add comments

N/A

—

5. During 2022, did the council resolve to proceed with each major land transaction or trading undertaking by absolute majority? * Add comments

N/A

—

Delegation of Power/Duty

1. Were all delegations to committees resolved by absolute majority? * Add comments

Yes

Please enter comments *

Resolved on 15/06/2022.

2. Were all delegations to committees in writing? * Add comments

Yes

Please enter comments *

Terms of Reference

3. Were all delegations to committees within the limits specified in section 5.17 of the Local Government Act 1995? * Add comments

Yes

Audit & Risk Management Committee Meeting Minutes
23 February 2023



—

4. Were all delegations to committees recorded in a register of delegations? * Add comments

Yes

—

5. Has council reviewed delegations to its committees in the 2021/2022 financial year? * Add comments

Yes

Please enter comments *

15/06/2022

6. Did the powers and duties delegated to the CEO exclude those listed in section 5.43 of the Local Government Act 1995? * Add comments

Yes

—

7. Were all delegations to the CEO resolved by an absolute majority? * Add comments

Yes

—

8. Were all delegations to the CEO in writing? * Add comments

Yes

Please enter comments *

Included in minutes and notified via Council's Motion Tracker.

9. Were all delegations by the CEO to any employee in writing? * Add comments

Yes

UNCONFIRMED

Audit & Risk Management Committee Meeting Minutes
23 February 2023



—

10. Were all decisions by the Council to amend or revoke a delegation made by absolute majority? * Add comments

Yes

—

11. Has the CEO kept a register of all delegations made under Division 4 of the Local Government Act 1995 to the CEO and to employees? * Add comments

Yes

—

12. Were all delegations made under Division 4 of the Act reviewed by the delegator at least once during the 2020/2021 financial year? * Add comments

Yes

—

13. Did all persons exercising a delegated power or duty under the Local Government Act 1995 keep, on all occasions, a written record in accordance with Local Government (Administration) Regulations 1996 regulation 19? * Add comments

Yes

Please enter comments *

Maintained within Register or Council's CRM.

Disclosure of Interest

1. Where a council member disclosed an interest in a matter and did not have participation approval under sections 5.68 or 5.69 of the Local Government Act 1995, did the council member ensure that they did not remain present to participate in discussion or decision making relating to the matter? * Add comments

Yes

Audit & Risk Management Committee Meeting Minutes
23 February 2023



—

2. Were all decisions regarding participation approval, including the extent of participation allowed and, where relevant, the information required by the Local Government (Administration) Regulations 1996 regulation 21A, recorded in the minutes of the relevant council or committee meeting? *

Add comments

N/A

—

3. Were disclosures under sections 5.65, 5.70 or 5.71A(3) of the Local Government Act 1995 recorded in the minutes of the meeting at which the disclosures were made? *

Add comments

Yes

—

4. Was a primary return in the prescribed form lodged by all relevant persons within three months of their start day? *

Add comments

Yes

—

5. Was an annual return in the prescribed form lodged by all relevant persons by 31 August 2022? *

Add comments

No

Please enter comments *

Cr Curtis lodged on 01/09/2022.

6. On receipt of a primary or annual return, did the CEO, or the mayor/president, give written acknowledgment of having received the return? *

Add comments

Yes

—

Audit & Risk Management Committee Meeting Minutes
23 February 2023



7. Did the CEO keep a register of financial interests which contained the returns lodged under sections 5.75 and 5.76 of the Local Government Act 1995? * Add comments

Yes

—

8. Did the CEO keep a register of financial interests which contained a record of disclosures made under sections 5.65, 5.70, 5.71 and 5.71A of the Local Government Act 1995, in the form prescribed in the Local Government (Administration) Regulations 1996, regulation 28? * Add comments

Yes

—

9. When a person ceased to be a person required to lodge a return under sections 5.75 and 5.76 of the Local Government Act 1995, did the CEO remove from the register all returns relating to that person? * Add comments

Yes

—

10. Have all returns removed from the register in accordance with section 5.88(3) of the Local Government Act 1995 been kept for a period of at least five years after the person who lodged the return(s) ceased to be a person required to lodge a return? * Add comments

Yes

—

11. Did the CEO keep a register of gifts which contained a record of disclosures made under sections 5.87A and 5.87B of the Local Government Act 1995, in the form prescribed in the Local Government (Administration) Regulations 1996, regulation 28A? * Add comments

Yes

—

Audit & Risk Management Committee Meeting Minutes
23 February 2023



12. Did the CEO publish an up-to-date version of the gift register on the local government's website? * Add comments

Yes

—

13. When people cease to be a person who is required to make a disclosure under section 5.87A or 5.87B of the Local Government Act 1995, did the CEO remove from the register all records relating to those people? * Add comments

N/A

—

14. Have copies of all records removed from the register under section 5.89A(6) Local Government Act 1995 been kept for a period of at least five years after the person ceases to be a person required to make a disclosure? * Add comments

Yes

—

15. Where an employee had an interest in any matter in respect of which the employee provided advice or a report directly to council or a committee, did that person disclose the nature and extent of that interest when giving the advice or report? * Add comments

Yes

—

16. Where council applied to the Minister to allow the CEO to provide advice or a report to which a disclosure under section 5.71A(1) of the Local Government Act 1995 relates, did the application include details of the nature of the interest disclosed and any other information required by the Minister for the purposes of the application? * Add comments

N/A

—

Audit & Risk Management Committee Meeting Minutes
23 February 2023



17. Was any decision made by the Minister under section 5.71B(6) of the Local Government Act 1995, recorded in the minutes of the council meeting at which the decision was considered? * Add comments

N/A

—

18. Did the local government prepare and adopt, by absolute majority, a code of conduct to be observed by council members, committee members and candidates within 3 months of the prescribed model code of conduct coming into operation (3 February 2021)? * Add comments

Yes

Please enter comments *

21/04/2021

19. Did the local government adopt additional requirements in addition to the model code of conduct? If yes, does it comply with section 5.104(3) and (4) of the Local Government Act 1995? * Add comments

N/A

—

20. Has the CEO published an up-to-date version of the code of conduct for council members, committee members and candidates on the local government's website? * Add comments

Yes

—

21. Has the CEO prepared and implemented a code of conduct to be observed by employees of the local government? * Add comments

Yes

—

Has the CEO published an up-to-date version of the code of conduct for employees on the local government's website? *

Yes



Disposal of Property

1. Where the local government disposed of property other than by public auction or tender, did it dispose of the property in accordance with section 3.58(3) of the Local Government Act 1995 (unless section 3.58(5) applies)? *

Add comments

No

Please enter comments *

2 x leases were entered into for a 'pop up' shop between the Shire of Northam and a lessee. The nature of the leases are for a maximum of three months to conduct a 'trial small businesses'. Leases are no longer offered with licence to occupy now preferred which ensures compliance with s3.58.

2. Where the local government disposed of property under section 3.58(3) of the Local Government Act 1995, did it provide details, as prescribed by section 3.58(4), in the required local public notice for each disposal of property? *

Add comments

Yes

—

Elections

1. Did the CEO establish and maintain an electoral gift register and ensure that all disclosure of gifts forms completed by candidates and donors and received by the CEO were placed on the electoral gift register at the time of receipt by the CEO and in a manner that clearly identifies and distinguishes the forms relating to each candidate in accordance with regulation 30G(1) and regulation 30G(2) of the Local Government (Elections) Regulations 1997? *

Add comments

Yes

—

2. Did the CEO remove any disclosure of gifts forms relating to unsuccessful candidates, or successful candidates that completed their term of office, from the electoral gift register, and retain those forms separately for a period of at least two years in accordance with regulation 30G(4) of the Local Government (Elections) Regulations 1997? *

Add comments

N/A

—

Audit & Risk Management Committee Meeting Minutes
23 February 2023



3. Did the CEO publish an up-to-date version of the electoral gift register on the local government's official website in accordance with regulation 30G(5) of the Local Government (Elections) Regulations 1997? *

Add comments

Yes

—

Finance

1. Has the local government established an audit committee and appointed members by absolute majority in accordance with section 7.1A of the Local Government Act 1995? *

Add comments

Yes

Please enter comments *

18/10/2021

2. Where the council delegated to its audit committee any powers or duties under Part 7 of the Local Government Act 1995, did it do so by absolute majority? *

Add comments

Yes

Please enter comments *

15/06/2022

3. Was the auditor's report for the financial year ended 30 June 2022 received by the local government by 31 December 2022? *

Add comments

Yes

Please enter comments *

21/12/2022

4. Where the local government determined that matters raised in the auditor's report prepared under section 7.9(1) of the Local Government Act 1995 required action to be taken, did the local government ensure that appropriate action was undertaken in respect of those matters? *

Add comments

Yes

—

Audit & Risk Management Committee Meeting Minutes
23 February 2023



5. Where matters identified as significant were reported in the auditor's report, did the local government prepare a report that stated what action the local government had taken or intended to take with respect to each of those matters? Was a copy of the report given to the Minister within three months of the audit report being received by the local government? *

Add comments

N/A

—

6. Within 14 days after the local government gave a report to the Minister under section 7.12A(4)(b) of the Local Government Act 1995, did the CEO publish a copy of the report on the local government's official website? *

Add comments

N/A

—

7. Was the auditor's report for the financial year ending 30 June 2022 received by the local government within 30 days of completion of the audit? *

Add comments

Yes

Please enter comments *

Finalised 15/12/2022, report granted on 16/12/2022.

Integrated Planning and Reporting

1. Has the local government adopted by absolute majority a strategic community plan? *

Add comments

Yes

Please provide the adoption date or the date of the most recent review *

15/06/2022

—

2. Has the local government adopted by absolute majority a corporate business plan? *

Add comments

Yes

Audit & Risk Management Committee Meeting Minutes
23 February 2023



Please provide the adoption date or the date of the most recent review *

15/06/2022

—

3. Does the corporate business plan comply with the requirements of Local Government (Administration) Regulations 1996 19DA(2) & (3)? *

Add comments

Yes

—

Local Government Employees

1. Were all CEO and/or senior employee vacancies advertised in accordance with Local Government (Administration) Regulations 1996, regulation 18A? *

Add comments

N/A

—

2. Was all information provided in applications for the position of CEO true and accurate? *

Add comments

N/A

—

3. Was the remuneration and other benefits paid to a CEO on appointment the same remuneration and benefits advertised for the position under section 5.36(4) of the Local Government Act 1995? *

Add comments

N/A

—

4. Did the CEO inform council of each proposal to employ or dismiss senior employee? *

Add comments

N/A

Audit & Risk Management Committee Meeting Minutes
23 February 2023



—

5. Where council rejected a CEO's recommendation to employ or dismiss a senior employee, did it inform the CEO of the reasons for doing so? *

Add comments

N/A

—

Official Conduct

1. Has the local government designated an employee to be its complaints officer? *

Add comments

Yes

Please enter comments *

17/03/2021

2. Has the complaints officer for the local government maintained a register of complaints which records all complaints that resulted in a finding under section 5.110(2)(a) of the Local Government Act 1995? *

Add comments

Yes

—

3. Does the complaints register include all information required by section 5.121(2) of the Local Government Act 1995? *

Add comments

Yes

—

4. Has the CEO published an up-to-date version of the register of the complaints on the local government's official website? *

Add comments

Yes

Audit & Risk Management Committee Meeting Minutes
23 February 2023



—

Other

1. Did the CEO review the appropriateness and effectiveness of the local government's financial management systems and procedures in accordance with the Local Government (Financial Management) Regulations 1996 regulations 5(2)(c) within the three financial years prior to 31 December 2022? Add comments

Yes

Please provide the date of council's resolution to accept the report.
*

21/12/2022

—

2. Did the CEO review the appropriateness and effectiveness of the local government's systems and procedures in relation to risk management, internal control and legislative compliance in accordance with Local Government (Audit) Regulations 1996 regulation 17 within the three financial years prior to 31 December 2022? Add comments

Yes

Please provide the date of council's resolution to accept the report.
*

21/12/2022

—

3. Where a disclosure was made under sections 5.87A or 5.87B of the Local Government Act 1995, were the disclosures made within 10 days after receipt of the gift? Did the disclosure include the information required by section 5.87C of the Act? Add comments

N/A

—

4. Did the local government prepare, adopt by absolute majority and publish an up-to-date version on the local government's website, a policy dealing with the attendance of council members and the CEO at events? Add comments

Yes

Audit & Risk Management Committee Meeting Minutes
23 February 2023



Please enter comments *

18/11/2020

5. Did the CEO publish information on the local government's website in accordance with sections 5.96A(1), (2), (3), and (4) of the Local Government Act 1995?

Add comments

No

Please enter comments *

Establishment, Maintenance and Equipment of Bush Fire Brigades - Gazetted 21/05/1982 was never repealed and not listed on the Shire of Northam website.

6. Did the local government prepare and adopt (by absolute majority) a policy in relation to the continuing professional development of council members?

Add comments

Yes

Please enter comments *

18/11/2020

7. Did the local government prepare a report on the training completed by council members in the 2021/2022 financial year and publish it on the local government's official website by 31 July 2022?

Add comments

Yes

—

8. By 30 September 2022, did the local government submit to its auditor the balanced accounts and annual financial report for the year ending 30 June 2022?

Add comments

Yes

—

9. When adopting the annual budget, did the local government take into account all its expenditure, revenue and income?

Add comments

Yes

—



Tenders for Providing Goods and Services

1. Did the local government comply with its current purchasing policy, adopted under the Local Government (Functions and General) Regulations 1996, regulations 11A(1) and (3) in relation to the supply of goods or services where the consideration under the contract was, or was expected to be, \$250,000 or less or worth \$250,000 or less? *

Add comments

Yes

—

2. Subject to Local Government (Functions and General) Regulations 1996, regulation 11(2), did the local government invite tenders for all contracts for the supply of goods or services where the consideration under the contract was, or was expected to be, worth more than the consideration stated in regulation 11(1) of the Regulations? *

Add comments

Yes

—

3. When regulations 11(1), 12(2) or 13 of the Local Government (Functions and General) Regulations 1996, required tenders to be publicly invited, did the local government invite tenders via Statewide public notice in accordance with Regulation 14(3) and (4)? *

Add comments

Yes

—

4. Did the local government comply with Local Government (Functions and General) Regulations 1996, Regulation 12 when deciding to enter into multiple contracts rather than a single contract? *

Add comments

N/A

—

5. If the local government sought to vary the information supplied to tenderers, was every reasonable step taken to give each person who sought copies of the tender documents or each acceptable tenderer notice of the variation? *

Add comments

Yes

Audit & Risk Management Committee Meeting Minutes
23 February 2023



Please enter comments *

Managed through Vendor Panel.

6. Did the local government's procedure for receiving and opening tenders comply with the requirements of Local Government (Functions and General) Regulations 1996, Regulation 15 and 16? * Add comments

Yes

—

7. Did the information recorded in the local government's tender register comply with the requirements of the Local Government (Functions and General) Regulations 1996, Regulation 17 and did the CEO make the tenders register available for public inspection and publish it on the local government's official website? * Add comments

Yes

—

8. Did the local government reject any tenders that were not submitted at the place, and within the time, specified in the invitation to tender? * Add comments

Yes

—

9. Were all tenders that were not rejected assessed by the local government via a written evaluation of the extent to which each tender satisfies the criteria for deciding which tender to accept? * Add comments

Yes

—

10. Did the CEO give each tenderer written notice containing particulars of the successful tender or advising that no tender was accepted? * Add comments

Yes

—

Audit & Risk Management Committee Meeting Minutes
23 February 2023



11. Did the local government's advertising and expression of interest processes comply with the requirements of the Local Government (Functions and General) Regulations 1996, Regulations 21 and 22? * Add comments

N/A

—

12. Did the local government reject any expressions of interest that were not submitted at the place, and within the time, specified in the notice or that failed to comply with any other requirement specified in the notice? * Add comments

N/A

—

13. Were all expressions of interest that were not rejected under the Local Government (Functions and General) Regulations 1996, Regulation 23(1) & (2) assessed by the local government? Did the CEO list each person as an acceptable tenderer? * Add comments

N/A

—

14. Did the CEO give each person who submitted an expression of interest a notice in writing of the outcome in accordance with Local Government (Functions and General) Regulations 1996, Regulation 24? * Add comments

N/A

—

15. Did the local government invite applicants for a panel of pre-qualified suppliers via Statewide public notice in accordance with Local Government (Functions and General) Regulations 1996, Regulations 24AD(4) and 24AE? * Add comments

N/A

—

Audit & Risk Management Committee Meeting Minutes
23 February 2023



16. If the local government sought to vary the information supplied to the panel, was every reasonable step taken to give each person who sought detailed information about the proposed panel or each person who submitted an application notice of the variation? * Add comments

N/A

—

17. Did the local government's procedure for receiving and opening applications to join a panel of pre-qualified suppliers comply with the requirements of Local Government (Functions and General) Regulations 1996, Regulation 16, as if the reference in that regulation to a tender were a reference to a pre-qualified supplier panel application? * Add comments

N/A

—

18. Did the information recorded in the local government's tender register about panels of pre-qualified suppliers comply with the requirements of Local Government (Functions and General) Regulations 1996, Regulation 24AG? * Add comments

N/A

—

19. Did the local government reject any applications to join a panel of pre-qualified suppliers that were not submitted at the place, and within the time, specified in the invitation for applications? * Add comments

N/A

—

20. Were all applications that were not rejected assessed by the local government via a written evaluation of the extent to which each application satisfies the criteria for deciding which application to accept? * Add comments

N/A

—

Audit & Risk Management Committee Meeting Minutes
23 February 2023



21. Did the CEO send each applicant written notice advising them of the outcome of their application? * Add comments

N/A

22. Where the local government gave regional price preference, did the local government comply with the requirements of Local Government (Functions and General) Regulations 1996, Regulation 24E and 24F? * Add comments

Yes

Documents

[7 days ago](#)
(09/02/2023 2:48 PM)
Alysha McCall

Code of conduct

2021.04.21 CODE OF CONDUCT.pdf (1.41 MB)
(/_entity/annotation/39aae1b6-45a8-ed11-aad1-002248962727/976c0132-2a5b-ed11-9562-00224893390b?t=1676508394017)

[7 days ago](#)
(09/02/2023 2:50 PM)
Alysha McCall

Auditor's Report

2022.12.21 ANNUAL REPORT.pdf (24.06 MB)
(/_entity/annotation/70f33fff-45a8-ed11-aad0-0022481117ad/976c0132-2a5b-ed11-9562-00224893390b?t=1676508394017)

[7 days ago](#)
(09/02/2023 2:50 PM)
Alysha McCall

Strategic & Corporate Plan

2022.06.15 STRATEGIC & CORPORATE PLAN.pdf (3.48 MB) (/_entity/annotation/24b4b50c-46a8-ed11-aad1-002248962727/976c0132-2a5b-ed11-9562-00224893390b?t=1676508394017)

Close Previous Next

Audit & Risk Management Committee Meeting Minutes
23 February 2023



6.5 PROGRESS TOWARDS THE REGULATION 17 REVIEW

File Reference:	8.2.7.1
Reporting Officer:	Alysha McCall, Acting Governance Coordinator
Responsible Officer:	Jason Whiteaker, Chief Executive Officer
Officer Declaration of Interest:	Nil
Voting Requirement:	Simple Majority
Press release to be issued:	No

BRIEF

To provide Council with an update of the progress made towards the Regulation 17 Review Action Plan that was presented to Council at the 21 December 2022 Ordinary Council Meeting for adoption.

This report aims to establish a level of accountability in respect to completing the actions identified through the Regulation 17 Review to ensure that Council's risk management, internal controls and legislative compliance is appropriate and effective.

ATTACHMENTS

Attachment 1: Regulation 17 Review Action Plan.

A. BACKGROUND / DETAILS

Section 17 of the Local Government (Audit) Regulations requires the Chief Executive Officer to review the appropriateness and effectiveness of the Council's systems and procedures as they relate to the following areas;

- Risk management
- Internal controls, and
- Legislative compliance

The Chief Executive Officer carried out the review internally, the attached report is supplied to Council with the findings and recommendations.

A report has then been prepared identifying the findings from the review along with recommendations (if applicable). These findings and recommendation have been developed into an action plan and provided in Attachment 1.

Audit & Risk Management Committee Meeting Minutes
23 February 2023



B. CONSIDERATIONS

B.1 Strategic Community / Corporate Business Plan

Performance Area: Performance.

Outcome 12: Excellence in organisational performance and customer service.

Objective 12.1: Maintain a high standard of corporate governance and financial management.

Priority Action 12.1.4: Provide internal auditing capabilities (including providing additional human or financial resources) and publish findings annually.

B.2 Financial / Resource Implications

Staffing resources are required in order to action the recommendations detailed within the BPR Action Plan.

B.3 Legislative Compliance

Local Government Act 1995 and relevant subsidiary legislation.

B.4 Policy Implications

Nil.

B.5 Stakeholder Engagement / Consultation

Nil.

B.6 Risk Implications

Risk Category	Description	Rating (consequence x likelihood)	Mitigation Action
Financial	Revenue loss to the Shire.	Low (2)	Managed by ensuring good practices
Health & Safety	N/A	N/A	N/A
Reputation	Disruption to current service.	Low (2)	Ensure IT and other services are managed professionally.
Service Interruption	Potential for IT and Administrative disruption	Low (1)	Ensure changes are managed professionally.
Compliance	Not compliant with legislation	Low (2)	Review legislation regularly
Property	N/A	N/A	N/A
Environment	N/A	N/A	N/A

B.7 Natural Environment Considerations

Not applicable.

Audit & Risk Management Committee Meeting Minutes
23 February 2023



C. OFFICER'S COMMENT

This review indicated that the Shire of Northam is proactive in managing risk, internal controls and legislative compliance as well as taking the necessary steps to ensure appropriate risk management, internal controls and legislative compliance policies and practices are in place. Areas for improvement and recommendations have been detailed in Attachment 1 with comments in respect to the progress made towards each of these.

Officers are working towards addressing the recommendations from the review whilst continuing the improvements already underway in order to achieve an optimum levels of risk management, internal controls and legislative compliance into the future. The Action Plan for Review has been provided in Attachment 1 with an update of the progress made towards the recommendations.

Key to table

- Completed** 
- No Action** 
- Underway** 

RECOMMENDATION / COMMITTEE DECISION
<p>Minute No: AU.245</p> <p>Moved: Cr Appleton Seconded: Cr Mencshelyi</p> <p>That Council receive the update as provided in the Attachment 1 in relation to the progress made towards the Regulation 17 Action Plan.</p> <p style="text-align: right;">CARRIED 3/0</p>



Audit & Risk Management Committee Meeting Minutes
23 February 2023

Attachment 1 – Regulation 17 Review Action Plan

Number	Area	Control	Recommendation	Responsible Officer	Progress To Date	Status
1	1. Risk Management	1.1 Reviewing whether the local government has an effective risk management system and that material operating risks to the local government are appropriately considered;	Review Risk Management Policy	Alysha McCall	Proposed to be workshopped with Council on 22 February 2023.	Underway
2	1. Risk Management	1.1 Reviewing whether the local government has an effective risk management system and that material operating risks to the local government are appropriately considered;	Develop a Risk Management Process	Alysha McCall	No progress.	No Action
3	1. Risk Management	1.2 Reviewing whether the local government has a current and effective business continuity plan (including disaster recovery) which is tested from time to time;	Review a Business Continuity Plan	Alysha McCall	No progress.	No Action
4	1. Risk Management	1.2 Reviewing whether the local government has a current and effective business continuity plan (including disaster recovery) which is tested from time to time;	Review the IT Disaster Recovery Plan	Colin Young	No Progress	No Action
5	1. Risk Management	1.2 Reviewing whether the local government has a current and effective business continuity plan (including disaster recovery) which is tested from time to time;	Establish a program to test the Business Continuity Plan and IT Disaster Recovery Plan annually to ensure efficacy.	Alysha McCall, Colin Young	No Progress.	No Action
6	1. Risk Management	1.3 Assessing the internal processes for determining and managing material operating risks in accordance with the local government's identified tolerance for risk, particularly in the following areas: 1.10 Ascertaining whether fraud and misconduct risks have been identified, analysed, evaluated, have an appropriate treatment plan which has been implemented, communicated, monitored and there is regular reporting and ongoing management of fraud and misconduct risks.	Review the Fraud and Corruption Plan prior to June 2023.	Alysha McCall	No progress.	No Action
7	1. Risk Management	1.3 Assessing the internal processes for determining and managing material operating risks in accordance with the local government's identified tolerance for risk, particularly in the following areas;	Develop internal audit framework to include audits on identified risks in the Fraud and Corruption Control Plan.	Alysha McCall	No progress.	No Action
8	1. Risk Management	1.3 Assessing the internal processes for determining and managing material operating risks in accordance with the local government's identified tolerance for risk, particularly in the following areas;	Implement an annual review and sign off for the Code of Conduct for Employees, Volunteers, Contractors and Agency Staff.	Janice Byers		No Action
9	1. Risk Management	1.3 Assessing the internal processes for determining and managing material operating risks in accordance with the local government's identified tolerance for risk, particularly in the following areas;	Provide staff with specific training on fraud controls and conducting investigations.	Janice Byers		No Action
10	1. Risk Management	1.3 Assessing the internal processes for determining and managing material operating risks in accordance with the local government's identified tolerance for risk, particularly in the following areas;	Review ICT Strategy prior to June 2024.	Colin Young, Kunal Sarma	No Progress	No Action
11	1. Risk Management	1.5 Assessing the adequacy of Local Government processes to manage insurable risks and ensure the adequacy of insurance cover, and if applicable, the level of self-insurance;	Implement systems to ensure appropriate insurance is maintained where required by the Shire of Northam for leases and licenses.	Alysha McCall	Documenting within Smartsheet leased properties and the requirements with respect to insurance. Review yet to be undertaken comparing the property insurance register to lease register.	Underway
12	2. Internal Control	2.2 Control of approval of documents, letters and financial records;	Staff to be provided with training/reminder of need to register certain documents whilst limiting access.	Alysha McCall	No Progress	No Action
13	2. Internal Control	2.3 Limit of direct physical access to assets and records;	Store physical lease and licence records in the Records room to ensure records are appropriately administered.	Alysha McCall	No Progress	No Action
14	2. Internal Control	2.8 Comparison of the result of physical cash and inventory counts with accounting records.	Develop process and procedure for offsite stock management.	Kristy Hopkins		No Action
15	3. Legislative Compliance	3.1 Reviewing the annual Compliance Audit Return and reporting to council the results of that review;	Have the Compliance Audit Return (CAR) undertaken independently once in every three years (next due for 2023 period) CAR completed progressively on a monthly basis as part of internal audit process.	Alysha McCall	No progress able to be taken until second quarter of 2023/24.	No Action
16	3. Legislative Compliance	3.2 How management is monitoring the effectiveness of its compliance and making recommendations for change as necessary;	Report non-compliances identified through internal audits to the Executive Management monthly meeting.	Alysha McCall, Tamika Van Beek	Executive Managers Meeting Agenda template (V8) has been updated and uploaded in to Promapps. This version will commence use in March 2023	Completed



Audit & Risk Management Committee Meeting Minutes
23 February 2023

Number	Area	Control	Recommendation	Responsible Officer	Progress To Date	Status
17	3. Legislative Compliance	3.3 Reviewing whether the local government has procedures for it to receive, retain and treat complaints, including confidential and anonymous employee complaints;	Review the Customer Service Charter	Colin Young	No Progress	No Action
18	3. Legislative Compliance	3.3 Reviewing whether the local government has procedures for it to receive, retain and treat complaints, including confidential and anonymous employee complaints;	Review the Manage Complaints Process incorporating the following: a) Translating services being provided where appropriate. b) Special arrangements that may be required for responding to particular client groups. c) Reference to the public interest disclosure and misconduct processes. d) Declaring interests. e) The Ombudsman's Conducting Investigations Guidelines. f) The Ombudsman's Procedural Fairness Guidelines. g) A review process in which the Complaint Handling Officer's decision is reviewed by a suitably experienced colleague/superior before the complaint is finalised. h) An independent internal review process. i) Consideration towards establishing a designated Complaint Handling Officer. j) A system for analysing complaint information to enable continuous improvement.	Alysha McCall, Colin Young	No Progress	No Action
19	3. Legislative Compliance	3.3 Reviewing whether the local government has procedures for it to receive, retain and treat complaints, including confidential and anonymous employee complaints;	Review the information available on the Shire of Northam website incorporating the following: a) Providing clear information that complaints are handled at no charge. b) Providing the information in the form of other languages and incorporating a "Listen" option.	Alysha McCall, Colin Young	No Progress	No Action
20	3. Legislative Compliance	3.3 Reviewing whether the local government has procedures for it to receive, retain and treat complaints, including confidential and anonymous employee complaints;	Include the effectiveness of the complaint handling system within the internal audit framework.	Alysha McCall, Colin Young	No Progress	No Action

Audit & Risk Management Committee Meeting Minutes
23 February 2023



6.6 PROGRESS TOWARDS THE FINANCIAL MANAGEMENT REVIEW

File Reference:	8.2.7.1
Reporting Officer:	Kudzai Matanga, Senior Accountant
Responsible Officer:	Colin Young Executive Manager Corporate Services
Officer Declaration of Interest:	Nil
Voting Requirement:	Simple Majority
Press release to be issued:	No

BRIEF

For the Audit Committee to receive a progress report for the Financial Management System Review report.

ATTACHMENTS

Attachment 1: Financial Management Review Action Plan

A. BACKGROUND / DETAILS

Macri Partners PTY Ltd were engaged to conduct the review for the period 1 July 2021 to 30 April 2022. In accordance with Regulation 5(2)(c) of the *Local Government Financial Management Regulations 1996* Council is required to have a review of its financial system to ensure its appropriateness and effectiveness at least once every three years.

This report is to provide Council with the progress that has been made against the recommendations within the Financial Management Review.

B. CONSIDERATIONS

B.1 Strategic Community / Corporate Business Plan

Theme Area 6: Governance & Leadership.

Outcome 6.3: The Shire of Northam council is a sustainable, responsive, innovative and transparent organisation.

Objective:

- Ensure robust financial management.
- Implement systems and processes which deliver outcomes for our community.
- Maintain a high standard of corporate governance.

B.2 Financial / Resource Implications

Audit & Risk Management Committee Meeting Minutes
23 February 2023



Nil

B.3 Legislative Compliance

Local Government Act (1995) Section 7.12A & Local Government Financial Management Regulations 1996 Regulation 5(2)(c)

B.4 Policy Implications

N/A.

B.5 Stakeholder Engagement / Consultation

Nil.

B.6 Risk Implications

Risk Category	Description	Rating (consequence x likelihood)	Mitigation Action
Financial	Nil	Nil	Nil
Health & Safety	Nil	Nil	Nil
Reputation	Nil	Nil	Nil
Service Interruption	Nil	Nil	Nil
Compliance	Nil	Nil	Nil
Property	Nil	Nil	Nil
Environment	Nil	Nil	Nil

B.7 Natural Environment Considerations

N/A

C. OFFICER'S COMMENT

The Auditor raised a number of findings within the Financial Management Systems Review that need to be addressed to ensure that best practices are being followed by Council. The issues raised are contained in attachment 1. The auditor's report provided recommendations on the best way to resolve the issues and additionally management comments have been put in place as well as actions taken. The level of risk for eight of the issues were considered moderate and five raised were low.

Audit & Risk Management Committee Meeting Minutes
23 February 2023



Key to table of Attachment 1

Completed

No Action

Underway

RECOMMENDATION / COMMITTEE DECISION

Minute No: AU.246

Moved: Cr Appleton

Seconded: Cr Mencshelyi

That Council receive the update as provided in the Attachment 1 in relation to the progress made towards the Financial Management Systems Review Action Plan.

CARRIED 3/0

UNCONFIRMED



Audit & Risk Management Committee Meeting Minutes
23 February 2023

Attachment 1 – Financial Management Review Action Plan

Number	Finding	Recommendation / Solution	Expected Completion	Responsibility	Progress To Date	Status
1	Bank Reconciliations - Bank reconciliations not being dated by reviewer.	1. The date of bank reconciliation review should be documented.	July 2022	Corporate Services / Finance	Monthly bank reconciliations are sent to Accountant for review and the accountant signs and confirms the bank rec.	Completed
2	Investments - Shire does not have a formally established and documented internal control procedures for investments.	1.An Investment Procedural Guideline should be drafted and adopted by the Shire that should be followed by employees to ensure control over investments and also to be compliant with S.19 of the Local Government (Financial Management) Regulations 1996. 2.The Shire should also establish and maintain an investment register indicating the name of the financial institute, amount of the investment, term of the investment and date of maturity.	July 2022	Corporate Services / Finance	1.An investment process has been established and will be added to PROMAPPS 2.An investment register was created and is reported monthly to council and includes the recommended information.	Completed
3	Investment Policy - The Shire's Investment Policy has not been reviewed by the Shire in the 2021 year as required by the policy.	1.The Investment Policy should be reviewed and presented to Council as required by the policy at the earliest and update the policy if required based on the investment objectives of the Shire	February 2023	Corporate Services / Finance	Investment Policy Updated Pending Council Approval. Policy being workshopped on 23/02/23	Underway
4	Investment Policy - The Shire's investment policy F4.3 requires that investments be spread to ensure that no single financial institute holds more than 50% of the Shire's investments.	1.The Shire should look at restructuring its investments at the earliest to comply with the requirements of the investment policy and minimise its exposure to financial risks.	February 2023	Corporate Services / Finance	Investments now meet the guidelines of the policy. Investment policy to be reviewed and workshopped on 23/02/23	Underway
5	Procurement of goods and services - The same staff issued and approved the purchase orders, receipted the goods/services, and also authorised the related supplier invoices.	1.Management should implement appropriate segregation of duties, particularly between authorisation of purchase order and approving relevant supplier invoices.	February 2023	Corporate Services / Procurement	Process edit is pending loading in Promaps where all purchase orders are to be checked for compliance by credit officer. A P.O officer can also be an authoriser for approved authorising thresholds however compliance will be verified by credit officer.	Underway
6	Procurement Policy - Policy allows for minor variations , however the minor variation is not specified.	1.The procurement policy should define a minor variation	February 2023	Corporate Services / Procurement	Procurement policy updated, pending Council adoption. Policy updates to be workshopped 23/02/23.	Underway
7	Credit Cards - Credit card statements had no documentary evidence of review by an officer independent of the cardholder	1.The monthly credit card statements of all credit cardholders should be reviewed by a senior officer independent of the cardholder and the reviewer should initial and date the credit card statement to indicate that the review was done in a timely manner	November 2022	Corporate Services / Finance	Credit cards statements being reviewed by both Senior Finance officer and the accountant. Accountant signs and dates the credit card statement	Completed
8	Creditors - Monthly Creditor reconciliations not dated by reviewer.	1.The reviewer should indicate the date of review on the monthly creditor reconciliations	July 2022	Corporate Services / Finance / Procurement	Monthly Creditor reports and reconciliations reviewed by accountant signed and dated.	Completed
9	Rates - Rate debts outstanding for more than 3 years approximately 29% of the total rates debts outstanding.	1.The recoverability of all long outstanding rate debts should be reviewed by the management and appropriate action be taken to recover them without delay. 2.Also the need to create a provision for doubtful debts in the annual financial report should be reviewed.	December 2022	Corporate Services / Finance	1.Of the current outstanding debt \$340,000 is related to one subdivision that that was held by a now insolvent company Council lawyers are progressing with legal action against the Outstanding debt. 2.The Annual Financial Report currently has a provision for doubtful debts which includes rate debt that is expected to be written off in the next 12 months.	Completed
10	Debtors - 86% of total sundry debtors have been outstanding for more than 90 days	1.The recoverability of all long outstanding sundry debts should be reviewed by the management and appropriate action be taken to recover them without delay. 2.Also the need to create a provision for doubtful debts in the annual financial report should be reviewed	December 2022	Corporate Services / Finance	1.Majority of the then reported Percentage was a capital grant from DFES which came through in June 22. debtors are reviewed monthly and the necessary follow ups are done. Accountant dates and signs of the monthly review. 2.No Action-The Annual Financial Report currently has a provision for doubtful debts	Completed
11	Creditors - Retention money for goods and services paid out tom supplier and the supplier set as a debtor	1.The management should ensure there are adequate controls in place to prevent erroneous payments to suppliers	July 2022	Corporate Services / Procurement	Procedures have been put in place to ensure retentions are withheld correctly	Completed
12	Credit Note Requisitions - Shire does not use a formal credit requisition form to raise credit notes relating to sundry debtors. Instead, credit notes are raised based on email requests from the staff requesting the credit note	1.The Shire should develop and use a formal credit note requisition form to be authorised by the responsible officer when a credit note needs to be raised.	February 2023	Corporate Services / Finance	1.Credit note requisition form created pending approval. 2.Credit note requisition process to be added in pro maps by Feb 23	Underway
13	Cancellation of Receipts - The Shire does not have a formally established and documented internal control procedure for cancellation of receipts.	1.The Shire should develop and use a documented internal control procedural guideline for the benefit of the relevant staff	February 2023	Corporate Services / Finance	Receipt Cancellation procedure documents done and added into promaps by Feb 23	Completed
14	Daily Receipting - There was no documentary evidence of a review of the daily receipting report.	1.The daily receipting report should be reviewed by an officer independent of the receipting function and the evidence of such review should be documented. Any discrepancies should be investigated and rectified without delay	July 2022	Corporate Services / Finance	Receipting batches are reviewed daily, and discrepancies are notified at that point by the Senior Finance Officer. Senior Finance Signs and dates the batches.	Completed



Audit & Risk Management Committee Meeting Minutes
23 February 2023

Number	Finding	Recommendation / Solution	Expected Completion	Responsibility	Progress To Date	Status
15	Front Counter Cash Register - All operators of the front counter cash register use the same password.	1.The management should seek the possibility of introducing different passwords for each operator or introducing documented procedures to minimise the risk of unauthorised or fraudulent transactions occurring.	July 2024	Corporate Services / Finance	Difficult to implement with the current ERP. To be resolved once we migrate to Altus	No Action
16	Payroll - Employee termination payment calculations were not evidenced as being reviewed and approved by a senior staff of the Shire.	1.Recommend that calculations of all termination payments are independently reviewed and the review be evidenced on the calculation sheet and it be retained.	July 2022	Corporate Services / Finance	These are currently being reviewed by both Senior Finance officer and Accountant who both sign and date the calculation sheet.	Completed
17	Payroll - We noted that in 3 out of 6 employee fortnightly payments we tested, there was no deduction authority in two instances and also anomalies were found in the amount deducted in one instance.	1.We recommend that supporting documents in respect of all deductions are retained and also care is taken to ensure that deductions are made in accordance with the deduction authority provided by the employees.	N/A	Corporate Services / Finance	Current procedures have all deduction amounts recorded against personal files.	Completed
18	Payroll - Employee pay slips show penalty as normal hours.	1.We recommend that management investigates this matter and take appropriate measures to rectify the issue.	TBA	Corporate Services / Finance	We hope the move to Altus will resolve this as efforts to get this resolved by IT vision with synergy have been fruitless.	No Action
19	General Journals - The same officer prepares and posts the journal entry without an independent review by a second officer.	1.We recommend that a senior person independent of the preparer reviews and authorises all journal entries before they are processed and evidence of authorisation retained.	July 2022	Corporate Services / Finance	Journals are signed off by either the Accountant, Senior Finance Officer or Exec Manager Corporate services.	Completed
20	General Journals - The Shire does not have a comprehensive documented policy or procedural guideline for general journals.	1.recommend that management develops and implements a comprehensive policy and procedures for the general journal process. The policy should be approved by the Council prior to being implemented.	February 2023	Corporate Services / Finance	More of a procedure guideline to be documented rather than a policy. Journals are done by Finance personnel and currently only the EMCS, Senior Accountant and senior finance officer can post journals. A guideline for journal procedure to be documented however currently the process is one initiates the journal and sends to another officer for authorisation.	Underway
21	Fixed Assets - Currently there is no process of formally documenting the disposal of assets i.e. Asset Disposal Form, and obtaining managements approval prior to disposal of individual assets.	1.We recommend that management introduce an Asset Disposal/Deletion form to formalise the asset disposals/deletions process, which should also be subject to appropriate authorisation.	December 2022	Corporate Services / Finance	Asset disposal form created, and procedure documented and uploaded in pro maps	Completed
22	Fixed Assets Reconciliation - That the monthly fixed asset reconciliations for the months of August 2021 to February 2022 have not been dated by the reviewer and the reconciliations for the months of March and April 2022 were not performed at the time of the review.	1.We recommend that monthly fixed asset reconciliations are performed in a timely manner and reviewed by an officer independent of the preparer and evidence of such review be documented on the reconciliation.	December 2022	Corporate Services / Finance	Fixed assets reconciled monthly by Senior Finance Officer and sent to Accountant for review. Accountant signs and dates.	Completed
23	IT Security Policy - The Shire does not have a formal (IT) Security Policy. Furthermore there is no formal process to review user access rights and privileges in the system to ensure they are in line with the responsibilities of individual staff member's roles/positions.	1.The Shire should develop a formal IT Security Policy and also ensure user access rights are periodically reviewed to ensure they are in line with individual staff roles and responsibilities.	N/A	Corporate Services / ICT	No Action	No Action

Audit & Risk Management Committee Meeting Minutes
23 February 2023



6.7 PROGRESS TOWARDS THE ICT STRATEGY PLAN

File Reference:	1.1.9.1
Reporting Officer:	Kudzai Matanga, A/Executive Manager Corporate Services
Responsible Officer:	Jason Whiteaker, Chief Executive Officer
Officer Declaration of Interest:	Nil
Voting Requirement:	Simple majority
Press release to be issued:	No

BRIEF

To provide Council with an update on the progress made towards the ICT Strategy Plan.

This report aims to establish a level of accountability in respect to completing the actions identified through the audit undertaken by LGIS in 2019 in order to ensure that continuous improvement occurs within the organisation.

ATTACHMENTS

Attachment 1: ICT Strategic Plan Action Plan.

A. BACKGROUND / DETAILS

The Shire of Northam is moving through a significant period of change and development. In recognition of this and the need to ensure that it can continue to meet the aspirations of the community, the Shire of Northam has undertaken to put in place a number of Strategic and Business Plans to deliver short, medium, and long term objectives. The Shire of Northam is providing committed strategic planning and leadership, focused on strengthening our community, providing growth, and diversifying the local economy.

B. CONSIDERATIONS

B.1 Strategic Community / Corporate Business Plan

Theme Area 6 Governance and Leadership

Outcome 1.1: The Shire of Northam is an attractive investment destination for a variety of economic sectors

Objective: Pursue a range of developments in sectors including retirement living, renewable energy, agribusiness, innovation, logistics and aviation; and



Embrace technology as an enabler for development, and lobby for high speed internet connectivity.

B.2 Financial / Resource Implications

To be advised / determined.

B.3 Legislative Compliance

Local Government Act 1995 and relevant subsidiary legislation.

B.4 Policy Implications

N/A

B.5 Stakeholder Engagement / Consultation

Nil

B.6 Risk Implications

Risk Category	Description	Rating (likelihood x consequence)	Mitigation Action
Financial	Lack of investment into ICT	Possible (3) x Medium (3) = Moderate (9)	ICT Strategic / forward planning involving stakeholders to determine needed and desired current and future outcomes that can be budgeted for.
Health & Safety	EOL/less than WHS ideal ICT hardware, RF and prolonged machine noise exposure	Possible (3) x Medium (3) = Moderate (9)	EOL hardware replacement decisions to consider WHS requirements. Suitable placement or enclosures for noisy ICT gear such as servers and switches.
Reputation	Slow take up of new technologies	Likely (4) x Minor (2) = Moderate (8)	ICT Team continuing to engage with Shire stakeholders, 3 rd party vendors, and other councils re: current and emerging technologies and methods of delivering desired services.

B.7 Natural Environment Considerations

N/A

Audit & Risk Management Committee Meeting Minutes
23 February 2023



C. OFFICER'S COMMENT

ICT services are presently provided to approximately 130 full time, part time, and casual employees across the following sites, Administration, Northam depot, Wundowie Depot, Northam library, Wundowie library, Bilya Koort Boodja Cultural centre, Visitor centre, Killara adult day care, Northam aquatic facility, the Wundowie swimming pool, Bush Fire Brigade facilities, as well as to the community and stakeholders. This ICT Strategic Plan establishes a course of action to guide the future development and delivery of ICT services for the Shire of Northam.

Key to table of Attachment 1

Completed
No Action
Underway

<p>RECOMMENDATION / COMMITTEE DECISION</p> <p>Minute No: AU.247</p> <p>Moved: Cr Mencshelyi Seconded: Cr Appleton</p> <p>That Council receives the update as provided in Attachment 1.</p> <p style="text-align: right;">CARRIED 3/0</p>
--

Clarification was sought in relation to:

- Which will occur first the ICT review or the completion of the Altus roll out?
The Executive Manager Corporate Services advised that the ICT review will be completed first. The Altus roll out is expected to have a 10 month timeframe and some of the end modules are not yet completely developed. The Executive Manager Corporate Services also advised that he would arrange for the Business Systems Coordinator, Kunal Sarma, to attend the next Audit & Risk Management Committee meeting and run through the process and ICT strategy.
- Is there potential for the Altus roll out timeframe to push out further than 10 months, as has happened in other councils?
The Executive Manager Corporate Services advised that in the cases of

Audit & Risk Management Committee Meeting Minutes
23 February 2023



other councils it was a staffing issue that caused the timeframe to blow out. A staff member will need to do 1 month of solid work on the Altus roll out and no other tasks, if they are split between their usual daily tasks plus the Altus work then the timeframe will need to extend. When our new Management Accountant starts the Altus roll out will their priority role.

- How long will the transition be and how much pressure will the finance team be under? The Executive Manager Corporate Services advised that a gradual roll out is preferred, but this will be happening in the background. Come July 1st 2023 the whole of the Altus system will be pushed out to the organisation. However, this means that the Budget for 2023/2024 will need to be completed in the old (current) system and transferred over once Altus is online.
- It was noted that the Auditors tender is up this year, The Executive Manager Corporate Services advised that we may do an Audit in late June depending on when the tenders are awarded.

UNCONFIRMED



Audit & Risk Management Committee Meeting Minutes
23 February 2023

Attachment 1 – ICT Strategy Plan Action Plan

Number	Area for Further Development	Recommendation / Action	Timeframe	Responsibility	Progress To Date	Status
1	Governance	ICT decisions and operations within the Shire will be controlled and guided through a formalised ICT Governance framework. This framework will ensure the alignment of ICT activities with business priorities.	2021 / 2026	Corporate Services / ICT	Draft strategic and operations plans developed. SLAs to be determined. February 2022 Update: In early discussions with external provider regarding SLAs. August 2022 Update: No progress. December 2022 Update: No progress.	Underway
2	Emerging Trends and Technologies	ICT policies and procedures need to be current enabling the organisation to conduct considered reviews of emerging technologies and trends, to ensure they meet current and emerging needs of the organisation.	2021 / 2026	Corporate Services / ICT	Acceptable Use and BYOD policies adopted.	Completed
3	Business Systems and Applications	Appropriately managed business systems and applications will help consolidate and streamline business processes.	2021 / 2026	Corporate Services / ICT	Inventory Register established. RFQ re: potential CRM/RMS upgrade/migration from Synergysoft occurring. February 2022 Update: Tenders have been received and staff will be evaluation and expecting to present to the next Audit Committee meeting. May 2022 Update: No progress. August: Staff are expecting to receive an overview of the Altus System within the month, this will then determine the best way forward.	Underway
4	Infrastructure and Technology	ICT has extensive assets and services under management. The best value and maximum benefit from this investment can only be obtained if suitably managed.	2021 / 2026	Corporate Services / ICT	Systems manual to be developed. Network communications infrastructure plan to be developed. February 2022 Update: No progress. May 2022 Update: No progress. August 2022, limited progress made largely around the Shires CCTV infrastructure which is having a needs assessment carried out. December 2022 Update: No progress.	Underway
5	Disaster Recovery	ICT needs to work with the organisation to establish mission critical services and ensure that disaster recovery and business continuity plans meet current and emerging needs	2021 / 2026	Corporate Services / ICT	Adhoc DR / Business Continuity plan in place and partially tested. Data retention plan developed	Completed
6	Security	The threat of cyber security incidents continues to rise. The Shire needs to develop and implement security policies and procedures to meet this increasing threat.	2021 / 2026	Corporate Services / ICT	Ongoing development and training will always be occurring. May 2022 Update: No progress. August 2022, No progress. December 2022 Update: No progress.	Underway
7	Project Management	The effective delivery of ICT projects requires a suitable management framework to be implemented	2022	Corporate Services / ICT	Project Management ICT Procedure to be developed. February 2022 Update: No progress. August 2022 Update: No progress. December 2022 Update: No progress.	No Action

Audit & Risk Management Committee Meeting Minutes
23 February 2023



7. URGENT BUSINESS APPROVED BY DECISION

Nil.

8. DATE OF NEXT MEETING

The next Audit and Risk Management Committee meeting is proposed to be held on 25 May 2023 at 5:00pm. (meeting date may vary depending on interim audit)

9. DECLARATION OF CLOSURE

There being no further business, the Shire President, Cr C R Antonio, declared the meeting closed at 5.50pm.

"I certify that the Minutes of the Audit & Risk Management Committee Meeting held on Friday, 23 February 2023 have been confirmed as a true and correct record."

_____ President

_____ Date

12.3 LOCAL EMERGENCY MANAGEMENT COMMITTEE MEETING HELD ON 02 MARCH 2023

Receipt of Minutes:

RECOMMENDATION / COUNCIL DECISION

Minute No: C.4685

Moved: Cr C R Antonio

That Council receive the minutes from the Local Emergency Management Committee meeting held on 02 March 2023.

CARRIED 8/0

Adoption of Recommendations:

RECOMMENDATION / COUNCIL DECISION

Minute No: C.4686

Moved: Cr C R Antonio

That Council:

1. Adopt the amended Contacts List – Part 8 of the Local Emergency Management Arrangements.
2. Authorise a Committee review by way of a Q & A session with the following Major Events:
 - a. Northam Motorsport Festival (Flying 50)
 - b. Avon Descent
 - c. National Ballooning Championship
 - d. World Woman's Ballooning Championship
3. Request all agencies to review section one (1) of the LEMA, in preparation for a review to occur at the next LEMC meeting.

CARRIED 8/0



Shire of Northam
Heritage, Commerce and Lifestyle

Shire of Northam

Minutes

Local Emergency Management Committee

02 March 2023

Local Emergency Management Committee Meeting Minutes
02 March 2023



DISCLAIMER

In certain circumstances members of the public are not entitled to inspect material, which in the opinion of the Chief Executive Officer is confidential, and relates to a meeting or a part of a meeting that is likely to be closed to members of the public.

No responsibility whatsoever is implied or accepted by the Shire of Northam for any act, omission, statement or intimation occurring during Council or Committee meetings.

The Shire of Northam disclaims any liability for any loss whatsoever and howsoever caused arising out of reliance by any person or legal entity on any such act, omission or statement of intimation occurring during Council or Committee meetings.

Any person or legal entity who acts or fails to act in reliance upon any statement, act or omission made in a Council or Committee meeting does so at that person's or legal entity's own risk.

In particular and without derogating in any way from the broad disclaimer above, in any discussion regarding any planning application or application for a licence, any statement or intimation of approval made by any member or Officer of the Shire of Northam during the course of any meeting is not intended to be and is not taken as notice of approval from the Shire of Northam.

The Shire of Northam advises that anyone who has any application lodged with the Shire of Northam must obtain and should only rely on WRITTEN CONFIRMATION of the outcome of the application and any conditions attaching to the decision made by the Shire of Northam in respect of the application.

The Shire of Northam advises that any plans or documents contained within this agenda may be subject to copyright law provisions (*Copyright Act 1968*, as amended) and that the express permission of the copyright owner(s) should be sought prior to their reproduction. It should be noted that copyright owners are entitled to take legal action against any persons who infringe their copyright. A reproduction of material that is protected by copyright may represent a copyright infringement.

Local Emergency Management Committee Meeting Minutes
02 March 2023



Contents

1.	DECLARATION OF OPENING.....	4
2.	ACKNOWLEDGEMENT TO COUNTRY.....	4
3.	ATTENDANCE.....	4
3.1	APOLOGIES	4
3.2	APPROVED LEAVE OF ABSENCE.....	4
3.3	ABSENT.....	5
4.	DISCLOSURE OF INTERESTS.....	5
5.	CONFIRMATION OF MINUTES	6
5.1	COMMITTEE MEETING HELD ON 01 DECEMBER 2022.....	6
6.	COMMITTEE REPORTS.....	7
6.1	AGENCY REPORTS AND ISG ACTIVATIONS.....	7
6.2	CONTACTS & RESOURCES – LOCAL EMERGENCY MANAGEMENT ARRANGEMENTS.....	19
6.3	LEMA – DISASTER PREPARATION, PREVENTION, RESPONSE & RECOVERY REVIEW	22
6.4	LEMA ONGOING REVIEW.....	25
7.	MOTIONS OF WHICH PREVIOUS NOTICE HAS BEEN GIVEN.....	27
8.	URGENT BUSINESS APPROVED BY DECISION.....	27
9.	SCHEDULED MEETINGS	27
10.	DECLARATION OF CLOSURE	28

Local Emergency Management Committee Meeting Minutes
02 March 2023



1. DECLARATION OF OPENING

The Presiding Member, Cr C R Antonio, declared the meeting open at 3:05pm.

2. ACKNOWLEDGEMENT TO COUNTRY

The Shire of Northam would like to acknowledge the Traditional Owners of the land on which we meet, the Ballardong and Whadjuk people of the Nyoongar nation and pay our respects to Elders, past, present, and emerging.

3. ATTENDANCE

Voting Members:

Presiding Member/Shire of Northam President	Chris Antonio
Proxy for Acting Executive Manager Development Services	Gordon Tester
Community Emergency Services Manager (Executive Officer)	Alex Espey
Dept. of Fire and Emergency Service	Drew Graham
Northam Regional Hospital	Jennifer Lee
Proxy for Local Emergency Coordinator (WA Police)	Martin Glynn

Non-voting Members:

Dept. of Communities - Housing	Christine Frank
Dept. of Education	Shane Wynne
Dept. of Fire and Emergency Service	Ash Smith
Dept. of Health	Margaret Smith
SEMC Secretariat	Yvette Grigg
Water Corporation	Larry Bayley
Governance Officer	Tamika Van Beek

3.1 APOLOGIES

Voting Members:

WA Police, Northam	Ross Eastman
WA Police, Wundowie	Aaron Honey

Non-voting Members:

St John Ambulance	Stew Greenan
Western Power	Chris Battista
Northam Bushfire Brigades (CBFCO)	Chris Marris
Northam State Emergency Service	Cheryl Greenough

3.2 APPROVED LEAVE OF ABSENCE

Nil.

Local Emergency Management Committee Meeting Minutes
02 March 2023



3.3 ABSENT

Voting Members:

Shire of Northam Local Recovery Coordinator	Chadd Hunt
Dept. of Communities – Emergency Services Unit	Jo Spadaccini

Non-voting Members:

Arc Infrastructure	Clinton Lobb
Australian Defence Force	David Wilson
Australian Border Force	Sharan Brown
Dept. Parks and Wildlife – Perth Hills	Sonya Vlaar
Dept. Parks and Wildlife – Wheatbelt	Graeme Keals
Dept. of Primary Industries & Regional Development	Jeff Russell
Fire & Rescue Northam	TBC
Fire & Rescue Wundowie	Jeffrey Roberts
Juniper (Aged Care)	Tony Carter
Main Roads WA Wheatbelt	Gren Putland
Northam Airport	Errol Croft
Public Health Nurse	Anne Foyer
Red Cross	Erin Fuery
Salvation Army	Andrew Lee
SERCO (Yongah Hill)	Geoffrey Pitout
Silver Chain	Dara Sagar
CEO	Jason Whiteaker

4. DISCLOSURE OF INTERESTS

Nil.

Members should fill in Disclosure of Interest forms for items in which they have a financial, proximity or impartiality interest and forward these to the Presiding Member before the meeting commences.

*As defined in section 5.60A of the Local Government Act 1995, a **financial interest** occurs where a Councillor / Committee Member, or a person with whom the Councillor / Committee Member is closely associated, has a direct or indirect financial interest in the matter. That is, the person stands to make a financial gain or loss from the decision, either now or at some time in the future.*

*As defined in section 5.61 of the Local Government Act 1995, an **indirect financial** interest includes a reference to a financial relationship between that person and another person who requires a Local Government decision in relation to the matter.*

Local Emergency Management Committee Meeting Minutes
02 March 2023



As defined in section 5.60B of the Local Government Act 1995, a person has a **proximity interest** in a matter if the matter concerns a proposed change to a planning scheme affecting land that adjoins the person's land; or a proposed change to the zoning or use of land that adjoins the person's land; or a proposed development (as defined in section 5.63(5)) of land that adjoins the person's land.

As defined in 34C of the Local Government (Administration) Regulations 1996, an **impartiality interest** means an interest that could, or could reasonably be perceived to, adversely affect the impartiality of the person having the interest and includes an interest arising from kinship, friendship or membership of an association.

5. CONFIRMATION OF MINUTES

5.1 COMMITTEE MEETING HELD ON 01 DECEMBER 2022

RECOMMENDATION / MOTION

Moved: Alex Espey
Seconded: Ash Smith

That the minutes of the Local Emergency Management Committee meeting held on 01 December 2022 be confirmed as a true and correct record of that meeting.

Reason:

Recommendation not carried due to non-voting committee member seconding the motion.

Local Emergency Management Committee Meeting Minutes
02 March 2023



6. COMMITTEE REPORTS

6.1 AGENCY REPORTS AND ISG ACTIVATIONS

File Reference:	5.1.2.1
Reporting Officer:	Alex Espey, Community Emergency Services Manager
Responsible Officer:	Jacky Jurmann, Acting Executive Manager Development Services
Officer Declaration of Interest:	Nil
Voting Requirement:	Simple
Press release to be issued:	No

BRIEF

For the committee to receive reports from agencies and discuss any issues on any emergencies that occurred since the previous meeting held on 01 December 2022. Agencies listed may include – Shire of Northam Bush Fire Brigades, Northam State Emergency Services, Northam Police, Wundowie Police, Department of Fire and Emergency Services, Department of Communities and Northam Regional Hospital.

ATTACHMENTS

- Attachment 1: DFES, Wheatbelt District Advisor Report: February/March 2023
- Attachment 2: DFES, Emergency Management Health Check: 30/01/2023
- Attachment 3: Department of Communities, District Emergency Services Officer – Wheatbelt Update: February 2023.
- Attachment 4: Department of Communities: Local Emergency Welfare Plan (provided as a separate confidential attachment)

A. BACKGROUND / DETAILS

Monthly reports provided, both in writing and verbally, by various agencies for discussion by the Committee.

B. CONSIDERATIONS

B.1 Strategic Community / Corporate Business Plan

Performance Area: Planet

Outcome: A resilient community

Local Emergency Management Committee Meeting Minutes
02 March 2023



Objective: Build community resilience to cope with natural disasters and emergencies, including pandemics, storms, flooding and fire.

Priority Action: Provide up to date Local Emergency Management Arrangements, including directory of emergency services.

B.2 Financial / Resource Implications

N/A

B.3 Legislative Compliance

N/A

B.4 Policy Implications

N/A

B.5 Stakeholder Engagement / Consultation

Committee provides and identifies stakeholder engagement and consultation requirements.

B.6 Risk Implications

Risk Category	Description	Rating (likelihood x consequence)	Mitigation Action
Financial	N/A	N/A	N/A
Health & Safety	N/A	N/A	N/A
Reputation	N/A	N/A	N/A
Service Interruption	N/A	N/A	N/A
Compliance	N/A	N/A	N/A
Property	N/A	N/A	N/A
Environment	N/A	N/A	N/A

B.7 Natural Environment Considerations

N/A

B. OFFICER'S COMMENT

Committee to discuss any outcomes / recommendations from reports for inclusion in local emergency management arrangements.

Local Emergency Management Committee Meeting Minutes
02 March 2023



RECOMMENDATION

That the Committee note the contents of the agency reports and update contacts list as identified.

Reason:

This recommendation was not considered during this meeting.

Discussions were held in relation to the attachments provided in the report.

- The SEMC Secretariat, Yvette Griggs, provided an overview of the attachments and noted an included list of achievements, recommending the list be used in future Local Emergency Management Committee meetings as an objective to work towards.
- Report from the Dept. of Communities was taken as read in the report as no relevant members were in attendance for discussion.

Committee members in attendance were invited to provide updates for their organisations.

- The Northam Regional Hospital member, Jenny Lee, advised of the outcomes from a recent internal evacuation undertaking and plans for improvement. She also noted that they have identified issues in communication regarding large/high risk upcoming events from the Shire or Northam and other emergency service organisations, leading to the Hospital lacking additional resources needed when these events take place. Further discussion was held regarding this.

Action Item:

- Identify a course of action to close the loop between all organisations regarding upcoming large/high risk events.

Local Emergency Management Committee Meeting Minutes
02 March 2023



Attachment 1 - DFES, Wheatbelt District Advisor Report: February/March 2023



Wheatbelt District Advisor Report February March 2023

LEMA Review

The work on compiling your feedback and developing the new LEMA improvement plan is continuing. The LEMA improvement plan is expected to be finalised by June 2023.

Just a reminder, this in no way affects the legislated requirement for you to review your plan every 5 years, so meanwhile, please ensure your plan is current. If you have any questions please don't hesitate to give me a call.

SEMC Website

A reminder that the SEMC website has changed locations. It has been brought under the WA government banner and is now available under the [WA.gov.au](https://www.wa.gov.au/organisation/state-emergency-management-committee) website at this link:

Western Australian EM Capability Framework (revised) and Local Government EM Capability summary reports.

DFES State Capability Team has undertaken a comprehensive review of the SEMC's Emergency Management Capability Framework. The purpose of the review is to ensure that the framework is consistent with evolving EM best practice and stakeholder needs.

The revised framework is currently out for consultation, closing on Friday 3 March 2023. You can download the draft framework and submit any feedback at this link;

<https://dfes.mysocialpinpoint.com.au/capabilityframework>

LG Capability Summary reports

The summary report of your EM capabilities as reported last year in the Capability Survey was recently sent to all Local Governments. It may be useful to the LEMC in the following ways;

- Informing EM exercising (choosing a capability to exercise)
- Informing LEMA
- Informing LEMC business plans or agendas.
- Informing potential risk treatment options
- Supporting business cases and/or funding applications
- Highlighting areas of success.

New LEMC Handbook and useful tools

The DEMAs across the state have just finished developing a contemporary LEMC handbook to assist local governments in the management of their LEMCs and to assist them as they work to meet their legislative requirements. The guide has a few templates at the back which may also be useful, agenda templates and a Terms of Reference template.

Local Emergency Management Committee Meeting Minutes
02 March 2023



The Handbook is currently out for consultation, you can download the draft document and submit your feedback here;

<https://dfes.mysocialpinpoint.com.au/localemergencymanagementcommitteehandbook>

Keeping LEMC agendas fresh and effective with a focus on resilience, capability, and risk reduction.

A LEMC Health checklist has been developed to assist LGs and LEMC members assess how their LEMC is progressing. *(Please refer to the LEMC Health check list as attached).* The intention is to work on this over a number of years, using a traffic light system to track your progress. Any of the gaps identified would make great discussion or action items for your LEMCs and will assist to build meaningful LEMC agendas.

Some key things you could consider immediately, discuss or even workshop at your LEMC are listed below;

- Have you taken the time to seriously consider your membership? Is it reflective of your community? (Suggestions include emergency services, state agencies, community groups/leaders, representatives of vulnerable groups, welfare/social service groups/non-government organisations, industry and business, essential service providers.)
- To build further resilience to prepare, respond and recovery from emergency events, have you considered developing partnerships for mutual aid or assistance with stakeholders in your area? Examples include neighbouring LGs, agencies, community organisations or industry and business.
- Consider assessing your capability summary report and identifying capability gaps. Discuss with your LEMC and encourage their input to determine if there are any areas of critical vulnerabilities. Encourage their input to advise of any emerging risks that they may know of.
- Do your LEMC members understand your risk profile? Besides bushfires what other hazards and possible impacts should LEMC members be aware of? Review your risk register or list of emergencies likely to occur.

Emergency Management Grants Programme for the next few years

Year	2023-24		2024-25	
	NDRR	AWARE	NDRR	AWARE
Round Open	24 April 2023	16 August 2023	25 April 2024	16 August 2024
Round Close	29 May 2023	20 September 2023	29 May 2024	20 September 2024
Assessment	3 July 2023	24 October 2023	3 July 2024	25 October 2024
Anticipated announcement	September 2023	January 2024	September 2024	January 2025

Local Emergency Management Committee Meeting Minutes
02 March 2023



National Disaster Risk Reduction Package

This is a Commonwealth funding package that has been made available through the National Emergency Management Agency (NEMA). The funding is for nationally significant initiatives that reduce systemic disaster risk at the national level. To be eligible it must have significant national and cross jurisdictional effect, impact and influence. So it is unlikely to suit your needs, but just to keep you informed in case you come across it.

If you have any queries in regard to any of our grant programmes please send through an email to our grants team on semc.grants@dfes.wa.gov.au or call Glen Daniel on 0477 344 822

Calendar of Events – next 6 months

Date	Event	Location	Comment
15 March 2023	NEWROC EM day & Exercise "Our capability and resilience in a Changing climate."	Venue tbc.	Not confirmed
28 March 2023	WEROC EM day & Exercise "Our capability and resilience in a changing climate"	Kellerberrin Recreation Centre	Confirmed #Note includes Narembeen.
29 March 2023	Wheatbelt DEMC	DFES office Northam	
May/June	North-western Wheatbelt LGs EM day & exercise "Our capability and resilience in a changing climate"	Tba	Proposed , not yet organised. #Note: Includes the Shires of Dandaragan, Moora, Dalwallinu, Wongan/Ballidu, Victoria Plains, Gingin and Chittering
21 June 2023	Wheatbelt DEMC	DFES office Northam	

Note: It is intended that the EM days be flexible enough to allow for other LGs outside that area to join if that date/location suits them better.

Yvette Grigg
District Emergency Management Advisor
Wheatbelt/Goldfields Esperance

30th January 2023



Attachment 2 - DFES, Emergency Management Health Check: 30/01/2023

	Key achievements	2022-2023	2023-2024	2024-2025
<p><i>Consider the questions in the tables below to identify any gaps and provide ideas for future LEMC agenda items.</i></p> <p>Planning to ensure preparedness</p>				
1.	Does your Local Government (LEMC) have a current set of SEMC endorsed Local Emergency Management Arrangements (LEMA)?	Complete		
2.	Are contact list and resource details kept current? (Contact details to be updated quarterly, resources at least annually)	In progress		
3.	Does the LEMA contain a local recovery plan?	Not started		
4.	Are the LEMC and the local government (LG) staff aware of who the local recovery coordinator is?			
5.	Has a group of internal LG staff been identified to assist the local recovery coordinator?			
6.	Has the local recovery coordinator and/or support staff as identified received recovery training?			
7.	Have any specific pre-event evacuation plans been considered for any communities at risk, i.e., those with limited access/egress or in high-risk areas?	Not applicable		



LOCAL EMERGENCY MANAGEMENT COMMITTEE HEALTH CHECK

8.	Are efforts made to inform LEMC members and the community of where the possible evacuation centres and/or muster points are?			
9.	Have vulnerable groups within the community been identified in case they require extra care or specific messaging etc. before during and after an emergency?			
10.	Has animal welfare been considered during welfare planning? Has consideration been given to a specific animal welfare plan?			
11.	Do MOUs or agreements for mutual aid exist across LG boundaries and/or with different agencies, community organisations or business partners for resource sharing?			
12.	Has any communication planning been carried out? (With special consideration for power outages and any identified contingencies).			



LOCAL EMERGENCY MANAGEMENT COMMITTEE HEALTH CHECK

	Key achievements	2021-2022	2022-2023	2023-2024
The LEMC is focussed on building resilience				
1.	Do your LEMC members fully understand their role? <ul style="list-style-type: none"> Do you have a "Terms of Reference" and/or an induction package to assist with understanding? 			
2.	Does your LEMC have appropriate membership? <ul style="list-style-type: none"> It should be representative of the local community, the risk profile and demographics Consider the following inclusions; emergency services, state agencies, community leaders, representatives of vulnerable groups, mental as well as physical health services, youth representatives and industry/business groups. 			
3.	Does your LEMC exercise annually? <ul style="list-style-type: none"> Outcomes of these exercises should be reported back to the LEMC for review and actioning 			
4.	Does your LEMC meet regularly? <ul style="list-style-type: none"> Schedules set in place early Times and venues suitable for members. 			
5.	Is it administered professionally with a full agenda? <ul style="list-style-type: none"> Reflective of current issues, outcomes from seasonal or incident reviews and exercises. Inclusive of issues pertaining to resilience building, ie ensuring the community is prepared for and can recovery from an emergency, not just respond to one. 			
6.	Is your LEMC aware of current funding opportunities? <ul style="list-style-type: none"> Consider working with neighbours or other partners to develop joint funding applications that may benefit your region. 			



LOCAL EMERGENCY MANAGEMENT COMMITTEE HEALTH CHECK

7.	Has your LEMC undertaken or begun the risk management process? <ul style="list-style-type: none"> Consider raising community awareness of these risks. The LEMC could discuss and document their current capabilities against these risks. 			
8.	Does your LEMC engage with neighbours to share knowledge and resources?			
Key achievements		2021-2022	2022-2023	2023-2024
Operational awareness and coordination				
1.	Do your LEMC members understand the roles and responsibilities of a Local Emergency Coordinator (LEC) during a major event?			
2.	Do both the LG and LEMC understand their roles and responsibilities in an Incident Support Group (ISG)?			
3.	Is the LG aware of the importance of maintaining situational awareness from the beginning of the event by attending the IMT as an observer and/or the ISG? <ul style="list-style-type: none"> Consider nomination of a LG/agency liaison officer 			
4.	Are the LG and LEMC aware of the contents of the Local Welfare Plan and understand any roles and responsibilities they may have? <ul style="list-style-type: none"> Local Welfare Liaison officer 			
Recovery – Impact Statement, Transition, and preparedness.				
1.	Are the LG and LEMC members aware of the requirements of the Impact Statement and how the transition from response to recovery occurs?			
2.	Are the LG and LEMC members familiar with the recovery plan and aware of their roles in the Local Recovery Coordination Group (LRCC)?			
3.	Are the above requirements in Planning, Operations and Recovery exercised?			

Local Emergency Management Committee Meeting Minutes
02 March 2023



Attachment 3 - Department of Communities, District Emergency Services Officer – Wheatbelt Update: February 2023.



District Emergency Services Officer – Wheatbelt Update: February 2023

In the event of an emergency please call the All Hazards - State On-Call Coordinator on 0418 943 853, this number is manned 24/7. emergencyservices@communities.wa.gov.au. (Not for public distribution)
Meetings, exercise details or information request can be emailed to joanne.spadaccini@communities.wa.gov.au

Name Change

Our Directorate has been changed from the Emergency Services Unit to Emergency Relief and Support. Our responsibilities and contact details remain the same.

Changes to LG and community contacts in the Local Emergency Welfare Plan

A copy of your relevant district LEWP was sent out over the past few months requesting that you verify the LGA's contact details, the details of your evacuation centres and any other contact information in the shire. Any changes received have been amended in the current Local Emergency Welfare Plan which can be tabled at the next meeting.

On going, if there are any changes to the contact numbers or details from those listed on the LEWP, could you please advise any changes to joanne.spadaccini@communities.wa.gov.au

LG Activation Tubs

Communities will be following up with each LG, to ensure everyone has their activation / good to go tubs ready in the event of an activation as confirming numbers of current LG staff who have completed Evacuation Centre training.

Training

Please advise if you would like training conducted for local government staff, this can be an introduction to opening an evacuation centre, to cover the first couple of hours as Communities staff are on route. Happy to work with Shires to ensure little impacts to normal operations. Please e-mail joanne.spadaccini@communities.wa.gov.au to request training. Happy to discuss at any time.

Emergency Relief and Support – All Hazards Update

- **Kimberley Floods** - The Department of Communities (Communities) is providing emergency welfare services to residents impacted by the Kimberley floods. As of 1 February 2023:
 - Communities is operating three Flood Help Centres (Broome, Fitzroy Crossing and Derby).
 - 136 people are in Communities' supported emergency accommodation in Broome and Derby.
 - Since opening the Disaster Relief Hotline on the 11 January 2023 until COB 1 February 2023, Communities has responded to a total of 773 calls.
 - 189 people have been repatriated.
 - 288 people have been assisted to relocate to alternative safe locations.
 - 750 properties spanning 17 remote communities and the Fitzroy Crossing town have had electrical safety assessments completed (or currently underway).
 - Communities is providing rent relief to public housing tenants in Fitzroy Crossing and tenants in impacted remote Aboriginal communities following the floods.
 - Communities is planning medium to long term accommodation options for people whose homes are uninhabitable due to the floods.
- **Bushfires** – At the same time Communities have responded to a number of bushfires requiring Evacuation Centres including:
 - Cervantes (Nambung)
 - Armadale
 - Henderson
 - Albany – Bakers Junction

Local Emergency Management Committee Meeting Minutes
02 March 2023



- Thomson Brook
- Donnybrook Complex
- Donnybrook (Glenn Mervyn)
- Toodyay
- **Strategic Opportunities**
 - Medium to Long term Accommodation – The SEMC has asked Communities to lead a cross-agency working group to prepare an issues paper about Government responsibilities for medium and long-term accommodation following an emergency.
 - State Support Plan – Emergency Relief and Support (formerly Emergency Welfare) – Communities has reviewed the State Support Plan and the State Emergency Management Committee Policy Branch has released it for consultation:
<https://dfes.mysocialpinpoint.com.au/statesupportplanemergencyreliefandsupport/emergencyreliefandsupport/>
 - Community Sector Capability – working with community support organisations to enhance the delivery and coordination of welfare services
 - Disaster Information Support Coordination Centre (DISCC) Guidelines – being reviewed at request of WA Police
 - People at Risk – developing a framework to promote a shared approach to preparedness, response and recovery for people at risk in emergencies
 - Emergency Financial Assistance – review of the State Emergency Financial Assistance initiatives.

If you would like any further information, please call my mobile 0429 102 614 or email joanne.spadaccini@communities.wa.gov.au.

Jo Spadaccini
District Emergency Services Officer - Wheatbelt
Department of Communities - Emergency Services Unit

Local Emergency Management Committee Meeting Minutes
02 March 2023



6.2 CONTACTS & RESOURCES – LOCAL EMERGENCY MANAGEMENT ARRANGEMENTS

File Reference:	5.1.2.4
Reporting Officer:	Alex Espey, Community Emergency Services Manager
Responsible Officer:	Jacky Jurmann, Acting Executive Manager Development Services
Officer Declaration of Interest:	Nil
Voting Requirement:	Simple
Press release to be issued:	No

BRIEF

To review Part 8 of the Local Emergency Management Arrangements.

ATTACHMENTS

Attachment 1: Contact List 2023 (provided as a separate confidential document)

A. BACKGROUND / DETAILS

The contacts list in Part 8 of the LEMA should be reviewed regularly to ensure that it is up to date and available to use in the event of an emergency.

At the previous meeting, members were requested to provide up to date contact details for their relevant agency.

B. CONSIDERATIONS

B.1 Strategic Community / Corporate Business Plan

Performance Area: Planet

Outcome: A resilient community

Objective: Build community resilience to cope with natural disasters and emergencies, including pandemics, storms, flooding and fire.

Priority Action: Provide up to date Local Emergency Management Arrangements, including directory of emergency services.

Local Emergency Management Committee Meeting Minutes
02 March 2023



B.2 Financial / Resource Implications

N/A

B.3 Legislative Compliance

Local Emergency Management Arrangements (LEMA) are developed and reviewed by the Shire as required under Section 41 of the Emergency Management Act 2005 where the local government is to ensure that emergency management arrangements are in place for their local government district.

B.4 Policy Implications

N/A

B.5 Stakeholder Engagement / Consultation

Stakeholder engagement and consultation is carried out as a role of this Committee.

B.6 Risk Implications

Risk Category	Description	Rating (likelihood x consequence)	Mitigation Action
Financial	N/A	N/A	N/A
Health & Safety	N/A	N/A	N/A
Reputation	N/A	N/A	N/A
Service Interruption	Contact list is out of date.	Medium (3) x Possible (3) = Moderate (9)	Regularly review contacts list.
Compliance	N/A	N/A	N/A
Property	N/A	N/A	N/A
Environment	N/A	N/A	N/A

B.7 Natural Environment Considerations

N/A

C. OFFICER'S COMMENT

Updated details are to be provided by Committee members with a new database to be developed, which will include regular updating reminders and be accessible to all members.

Local Emergency Management Committee Meeting Minutes
02 March 2023



RECOMMENDATION / COMMITTEE DECISION

Minute No: LEMC.54

Moved: Jenny Lee

Seconded: Drew Graham

That Council adopt the amended Contacts List – Part 8 of the Local Emergency Management Arrangements.

CARRIED 6/0

Discussion was held regarding this item and clarification was provided on potential modifications to be made to simplify the document and enable regular update requests to be automated and reduce administration required. The Committee decided the updates should occur every 3 months for members and every 6 months for resources. It was also recommended that appropriate membership be checked at each meeting.

Local Emergency Management Committee Meeting Minutes
02 March 2023



6.3 LEMA – DISASTER PREPARATION, PREVENTION, RESPONSE & RECOVERY REVIEW

File Reference:	5.1.2.4
Reporting Officer:	Alex Espey, Community Emergency Services Manager
Responsible Officer:	Jacky Jurmann, Acting Executive Manager Development Services
Officer Declaration of Interest:	Nil
Voting Requirement:	Simple
Press release to be issued:	No

BRIEF

To discuss the most appropriate way to review the Local Emergency Management Arrangements and agency roles and responsibilities.

ATTACHMENTS

Nil

A. BACKGROUND / DETAILS

At the previous Local Emergency Management Committee Meeting it was agreed to review a risk component of the LEMA at each meeting that takes into consideration any upcoming events.

Discussions with the DEMA indicate that it would be more appropriate to review the risks in the context of disasters that may affect a larger proportion of the Northam community.

Considerations include but not limited to, economic, reputational, political, and capability.

B. CONSIDERATIONS

B.1 Strategic Community / Corporate Business Plan

Performance Area: Planet

Outcome: A resilient community

Objective: Build community resilience to cope with natural disasters and emergencies, including pandemics, storms, flooding and fire.

Local Emergency Management Committee Meeting Minutes
02 March 2023



Priority Action: Provide up to date Local Emergency Management Arrangements, including directory of emergency services.

B.2 Financial / Resource Implications

N/A

B.3 Legislative Compliance

Local Emergency Management Arrangements (LEMA) are developed and reviewed by the Shire as required under Section 41 of the Emergency Management Act 2005 where the local government is to ensure that emergency management arrangements are in place for their local government district.

B.4 Policy Implications

N/A

B.5 Stakeholder Engagement / Consultation

Stakeholder engagement and consultation is carried out as a role of this Committee.

B.6 Risk Implications

Risk Category	Description	Rating (likelihood x consequence)	Mitigation Action
Financial	N/A	N/A	N/A
Health & Safety	N/A	N/A	N/A
Reputation	N/A	N/A	N/A
Service Interruption	Arrangements are out of date.	Medium (3) x Possible (3) = Moderate (9)	Regularly review the arrangements.
Compliance	N/A	N/A	N/A
Property	N/A	N/A	N/A
Environment	N/A	N/A	N/A

B.7 Natural Environment Considerations

N/A

C. OFFICER'S COMMENT

It is important for the LEMC to be prepared for a response to a disaster event and that these meetings are utilised to ensure that the arrangements are current and relevant.

Local Emergency Management Committee Meeting Minutes
02 March 2023



RECOMMENDATION / COMMITTEE DECISION

Minute No: LEMC.55

Moved: Jenny Lee

Seconded: Martin Glynn

That Council authorise a Committee review by way of a Q & A session with the following Major Events:

- 1. Northam Motorsport Festival (Flying 50)**
- 2. Avon Descent**
- 3. National Ballooning Championship**
- 4. World Woman's Ballooning Championship**

CARRIED 6/0

Discussion was held in relation to major events that occur in the Shire of Northam, particularly upcoming events for 2023. The Committee came to the decision to hold Q & A sessions with event organisers prior to their event and discuss statistics from previous years and plans for needed emergency support at event. The Committee will look in to holding an Out of Session meeting to discuss the upcoming Ballooning events prior to the next scheduled Local Emergency Management Committee meeting.

Local Emergency Management Committee Meeting Minutes
02 March 2023



6.4 LEMA ONGOING REVIEW

File Reference:	5.1.2.4
Reporting Officer:	Alex Espey, Community Emergency Services Manager
Responsible Officer:	Jacky Jurmann, Acting Executive Manager Development Services
Officer Declaration of Interest:	Nil
Voting Requirement:	Simple
Press release to be issued:	No

BRIEF

The Local Emergency Management Committee are to review the intent and purpose of the committee.

ATTACHMENTS

Nil

A. BACKGROUND / DETAILS

The Shire of Northam would like to introduce a renewed focus on the Local Emergency Management Committee (LEMC) and its intent.

Consideration should be given to the direction and intent of the LEMC by elimination of unnecessary process' and information, and the introduction of absent process' and information through a multi-agency gap analysis.

B. CONSIDERATIONS

B.1 Strategic Community / Corporate Business Plan

Performance Area: Planet

Outcome: A resilient community

Objective: Build community resilience to cope with natural disasters and emergencies, including pandemics, storms, flooding and fire.

Priority Action: Provide up to date Local Emergency Management Arrangements, including directory of emergency services.

B.2 Financial / Resource Implications

N/A

Local Emergency Management Committee Meeting Minutes
02 March 2023



B.3 Legislative Compliance

Local Emergency Management Arrangements (LEMA) are developed and reviewed by the Shire as required under Section 41 of the Emergency Management Act 2005 where the local government is to ensure that emergency management arrangements are in place for their local government district.

B.4 Policy Implications

N/A

B.5 Stakeholder Engagement / Consultation

Stakeholder engagement and consultation is carried out as a role of this Committee.

B.6 Risk Implications

Risk Category	Description	Rating (likelihood x consequence)	Mitigation Action
Financial	N/A	N/A	N/A
Health & Safety	N/A	N/A	N/A
Reputation	N/A	N/A	N/A
Service Interruption	Arrangements are out of date.	Medium (3) x Possible (3) = Moderate (9)	Regularly review the arrangements.
Compliance	N/A	N/A	N/A
Property	N/A	N/A	N/A
Environment	N/A	N/A	N/A

B.7 Natural Environment Considerations

N/A

C. OFFICER'S COMMENT

Review of previous LEMC documents indicate an array of unnecessary or expired information, and the absence of potentially important procedures and information, specifically in relation to the preparation and recovery phases of a major incident.

It is important that the LEMC is prepared to act in the event of an emergency by having an up-to-date LEMA.

Local Emergency Management Committee Meeting Minutes
02 March 2023



RECOMMENDATION / COMMITTEE DECISION

Minute No: LEMC.56

Moved: Alex Espey

Seconded: Martin Glynn

That Council request all agencies to review section one (1) of the LEMA, in preparation for a review to occur at the next LEMC meeting.

CARRIED 6/0

Discussion was held regarding the committees intended purpose, including but not limited to gaining an understanding of each organisation capabilities in emergency situations.

Action Items:

- Provide a refresher at the next meeting to cover:
 - What is a Local Emergency Management Committee?
 - Why is it useful?
 - What should the committee be doing?
- Present a refresher regarding memberships and provide as induction to new members.

7. MOTIONS OF WHICH PREVIOUS NOTICE HAS BEEN GIVEN

Nil.

8. URGENT BUSINESS APPROVED BY DECISION

Nil.

9. SCHEDULED MEETINGS

06 July 2023.

An Out of Session meeting may be held prior to next scheduled meeting to conduct a Q & A meeting with the organisers of the upcoming Ballooning event. The Community Emergency Services Manager, Alex Espey, will organise.

Local Emergency Management Committee Meeting Minutes
02 March 2023



10. DECLARATION OF CLOSURE

There being no further business, the Presiding Member, Cr C R Antonio, declared the meeting closed at 4:12pm.

"I certify that the Minutes of the Local Emergency Management Committee held on Thursday, 02 March 2023 have been confirmed as a true and correct record."

_____ Presiding Member

_____ Date

UNCONFIRMED

13 OFFICER REPORTS

13.1 CEO'S OFFICE

13.1.1 2023 Local Government Ordinary Elections

File Reference:	2.2.1.1
Reporting Officer:	Alysha McCall (Governance Coordinator)
Responsible Officer:	Jason Whiteaker (Chief Executive Officer)
Officer Declaration of Interest:	Nil
Voting Requirement:	Absolute Majority
Press release to be issued:	No

BRIEF

For Council to determine the Electoral Commissioner to be responsible for the 2023 ordinary elections and incorporate these expenses into the 2023/24 Draft Annual Budget.

ATTACHMENTS

1. WA Electoral Commission Cost Estimate [**13.1.1.1** - 3 pages]

A. BACKGROUND / DETAILS

The next local government ordinary elections are being held on 21 October 2023. In preparation for this election, the WA Electoral Commission is seeking information from local governments with respect to whether it wishes them to be responsible for the conduct of the election.

The state government is currently considering local government reforms and as part of this process the method for electing the Shire President has changed to election by the electors rather than election by the Council.

The proposal from the WA Electoral Commission is based on 4 vacancies including the election of the President. The Shire of Northam is currently awaiting the outcome from the Local Government Advisory Board in relation to the Ward and Representation Review which may impact the number of vacancies. Should the decision of Council be supported, this will result in 3 vacancies for the new East ward and the Election of the Shire President.

B. CONSIDERATIONS

B.1 Strategic Community / Corporate Business Plan

Performance Area: Performance.

Outcome 13: A well informed and engaged community.

Objective 13.1: Provide strong, open and accountable leadership and be more visible and relevant for community members.

Priority Action: Nil.

B.2 Financial / Resource Implications

The estimated cost for the 2023 election if conducted as a postal ballot is \$54,000 including GST.

B.3 Legislative Compliance

Local Government Act 1995, section 4.20(4).

B.4 Policy Implications

Nil.

B.5 Stakeholder Engagement / Consultation

Nil.

B.6 Risk Implications

Risk Category	Description	Rating (likelihood x consequence)	Mitigation Action
Financial	Insufficient budget to conduct the Ordinary Elections.		Endorse the quoted amount to be included in the 2023/24 draft budget.
Health & Safety	Nil.		
Reputation	Nil.		
Service Interruption	Nil.		
Compliance	Non-compliance with <i>Local Government Act 1995</i> and subsidiary legislation.		Appoint the Electoral Commissioner to conduct the election in accordance with section 4.20(4) and 4.61(2).
Property	Nil.		
Environment	Nil.		

B.7 Natural Environment Considerations

Nil.

C. OFFICER'S COMMENT

Officers have sought information in relation to when an outcome will be provided for the Ward and Representation Review. The Local Government Advisory Board has outlined that it is not possible to advise when a response will be provided on the Shire's review, however have confirmed that it is currently in process.

RECOMMENDATION / COUNCIL DECISION

Minute No: C.4687

Moved: Cr M P Ryan

Seconded: Cr A J Mencshelyi

That Council:

- 1. Declare, in accordance with section 4.20(4) of the Local Government Act 1995, the Electoral Commissioner to be responsible for the conduct of the 2023 ordinary elections together with any other elections or polls which may be required;**
- 2. Decide, in accordance with section 4.61(2) of the Local Government Act 1995 that the method of conducting the election will be as a postal election;**
- 3. Include \$54,000 including GST in the Draft 2023/24 Annual Budget.**

**BY ABSOLUTE MAJORITY
CARRIED 8/0**

LGE 028

Mr Jason Whiteaker
Chief Executive Officer
Shire of Northam
PO Box 613
NORTHAM WA 6401

Dear Mr Whiteaker

Local Government Ordinary Election: 2023

The next local government ordinary elections are being held on 21 October 2023. While this is still some distance in the future, I have enclosed an estimate for your next ordinary election to assist in your 2023/2024 budget preparations.

The estimated cost for the 2023 election if conducted as a postal ballot is \$54,000 inc GST, which has been based on the following assumptions:

- 8,000 electors
- response rate of approximately 40%
- 4 vacancies
- count to be conducted at the offices of the Shire of Northam
- appointment of a local Returning Officer
- regular Australia Post delivery service to apply for the lodgement of the election packages.

An additional amount of \$1,725 will be incurred if your Council decides to opt for the Australia Post Priority Service for the lodgement of election packages.

179916

The Commission is required by the *Local Government Act* to conduct local government elections on a full cost recovery basis and you should note that this is an estimate only and may vary depending on a range of factors.

Costs not incorporated in this estimate include:

- any legal expenses other than those that are determined to be borne by the Western Australian Electoral Commission incurred as part of an invalidity complaint lodged with the Court of Disputed Returns
- the cost of any casual staff to assist the Returning Officer on election day or night
- any unanticipated costs arising from public health requirements for the COVID-19 pandemic.

As you are aware, the Government is currently considering reforms to the *Local Government Act 1995*, which include how elections are to be conducted. In order to assist with your local government's budget planning, we have included, to the best of our knowledge, costs that will arise from the changes proposed in legislation. For example, if under the amendments your local government will be required to conduct a mayoral/presidential election this has been included.

Some local governments may also note an increase in costs from their 2021 ordinary costs. These include increases arising from inflation in recent years affecting salaries for Returning Officers and other staff, printing and packaging costs as well as the increase in postage announced by Australia Post. Additional costs from the Commission have been included arising from improved processing procedures and additional resources to supplement the Commission's education, complaints management, investigation and legal efforts.

In order for the Commission to be responsible for the conduct of your election, the first step required by the *Local Government Act 1995* is my written agreement to undertake the election.

As such, you may take this letter as my agreement to be responsible for the conduct of the ordinary elections in 2023 for the Shire of Northam in accordance with section 4.20(4) of the *Local Government Act 1995*, together with any other elections or polls that may also be required. My agreement is subject to the proviso that the Shire of Northam also wishes to have the election undertaken by the Western Australian Electoral Commission as a postal election.

In order to achieve this, your council would need to pass the following two motions by absolute majority:

- Declare, in accordance with section 4.20(4) of the *Local Government Act 1995*, the Electoral Commissioner to be responsible for the conduct of the 2023 ordinary elections together with any other elections or polls which may be required
- Decide, in accordance with section 4.61(2) of the *Local Government Act 1995* that the method of conducting the election will be as a postal election.

It would be greatly appreciated if this item was considered at your March council meeting, to enable the Commission to have sufficient time to work with you to effectively conduct the election.

I look forward to conducting this election for the Shire of Northam in anticipation of an affirmative vote by Council. If you have any further queries please contact Shani Wood Director, Election Operations on 9214 0400.

Yours sincerely



Robert Kennedy
ELECTORAL COMMISSIONER

9 February 2023

13.1.2 Renewal of Lease for Uniting Church Homes (Juniper) - 63 Wellington Street, Northam

File Reference:	A12515
Reporting Officer:	Alysha McCall (Governance Coordinator)
Responsible Officer:	Jason Whiteaker (Chief Executive Officer)
Officer Declaration of Interest:	Nil
Voting Requirement:	Simple Majority
Press release to be issued:	No

BRIEF

For Council to renew the lease for 63 Wellington Street, Northam to Uniting Church Homes (Juniper).

ATTACHMENTS

1. Map of Leased Area [13.1.2.1 - 1 page]

A. BACKGROUND / DETAILS

A lease agreement was entered into with Uniting Church Homes in September 2020. Records indicate that this lease was entered into under delegated authority reference F06 – Disposing of Property by Lease or Licence which allows the Chief Executive Officer to approve disposals of property where the below criteria is met:

- (i) The lease being in accordance with the Shire's Leasing Policy (as then applicable);
- (ii) The term of the lease being no greater than twelve (12) years for Northam Airport Hangar Sites and five (5) years for all other property;
- (iii) The rental fee payable being no greater than \$20,000 (plus GST) per annum during the initial year of the lease term; and
- (iv) The area leased being no greater than 1000m².

Upon reviewing the lease to exercise the renewal option, it was identified that this lease did not meet criteria (iv) listed above and as such this item is presented to Council to authorise the renewal of the lease.

At the time of entering into the lease, a valuation was obtained which confirmed the market rent at \$17,300 per annum (GST Exclusive).

B. CONSIDERATIONS

B.1 Strategic Community / Corporate Business Plan

Performance Area: Performance.

Outcome 12: Excellence in organisational performance and customer service.

Objective 12.3: Effectively manage the Shire's assets.

Priority Action 12.3.3: Provide well maintained Shire buildings.

B.2 Financial / Resource Implications

The Shire of Northam entered into the lease for \$17,000 per annum excluding GST. The Shire of Northam currently receives \$19,062.46 per annum in lease fees due to the increases associated with CPI.

B.3 Legislative Compliance

Local Government Act 1995

Local Government (Functions and General) Regulations 1996

30. Dispositions of property excluded from Act s. 3.58

- (b) the land is disposed of to a body, whether incorporated or not —
- (i) the objects of which are of a charitable, benevolent, religious, cultural, educational, recreational, sporting or other like nature; and
 - (ii) the members of which are not entitled or permitted to receive any pecuniary profit from the body's transactions;

This disposal can be treated as exempt under regulation 30 detailed above as:

- The objects of the lease agreement are for benevolent purposes; and
- Uniting Church Homes members are not entitled or permitted to receive any profit from the transactions as a registered not-for-profit and charitable organisation.

B.4 Policy Implications

A 8.5 Management of Council Property Leases

3.0 Subsidised Community Not-For-Profit: Reg 30(2)(b)

3.2 Lessee Responsibilities

3.2.1 Specified annual rent;

3.2.2 Maintenance, cleaning and operational expenses are provided by the Lessee;

3.2.3 Outgoings, utility charges, rates etc are paid by the Lessee

3.2.4 Minor and Major maintenance is managed by the Lessee.

3.2.5 All associated Lease fees are paid by the Lessee.

B.5 Stakeholder Engagement / Consultation

Officers have liaised with Uniting Church Homes who have confirmed that they wish to exercise the renewal option within the lease.

B.6 Risk Implications

Risk Category	Description	Rating (likelihood x consequence)	Mitigation Action
Financial	Loss of revenue from lease fees.	Minor (2) x Possible (3) = Moderate (6)	Renew the lease with Uniting Church Homes.
Health & Safety	Nil.		
Reputation	Nil.		
Service Interruption	Nil.		
Compliance	Non-compliance with disposal requirements within <i>Local Government Act 1995</i> .	Minor (2) x Unlikely (2) = Low (4)	Apply the requirements of the <i>Local Government Act 1995</i> and <i>Local Government (Functions and General) Regulations 1996</i>
Property	Damage to property.	Medium (3) x Possible (3) = Moderate (9)	Ensure appropriate processes are in place to report damage and ensure security of premise. Ensure appropriate insurance is in place.
Environment	Nil.		

B.7 Natural Environment Considerations

Nil.

C. OFFICER'S COMMENT

Nil.

RECOMMENDATION / COUNCIL DECISION

Minute No: C.4688

Moved: Cr D A Hughes

Seconded: Cr R W Tinetti

That Council approve the renewal of lease for 63 Wellington Street, Northam to Uniting Church Homes commencing on 1 May 2023 and terminating on 30 April 2025 in accordance with all covenants and conditions contained, expressed or implied in the Lease.

CARRIED 8/0



Cr R W Tinetti declared an “Impartiality” interest in item 13.1.3 - Request to operate a Gyrocopter – Northam Airport, as the President and several members of the Northam Aero Club are known to Cr Tinetti.

Cr M I Girak declared an “Impartiality” interest in item 13.1.3 – Request to operate a Gyrocopter – Northam Airport, as some members of the Aero Club are known to Cr Girak.

13.1.3 Request to operate a Gyrocopter - Northam Airport

File Reference:	A12838
Reporting Officer:	Alysha McCall (Governance Coordinator)
Responsible Officer:	Jason Whiteaker (Chief Executive Officer)
Officer Declaration of Interest:	Nil
Voting Requirement:	Simple Majority
Press release to be issued:	No

BRIEF

For Council to consider a request to operate a gyrocopter from the Northam Airport.

ATTACHMENTS

1. CONFIDENTIAL REDACTED - Applicant request to operate a Gyrocopter at the Northam Airport [**13.1.3.1** - 3 pages]
2. Correspondence to Northam Aero Club seeking comment on application [**13.1.3.2** - 2 pages]
3. Northam Aero Club Response [**13.1.3.3** - 1 page]
4. CONFIDENTIAL REDACTED - Submission received from Hangar owner [**13.1.3.4** - 2 pages]

A. BACKGROUND / DETAILS

At the Ordinary Council Meeting held on 13 August 2008, Council endorsed the Rules of Operation for the Northam Airport. This restricted gyrocopters from operating at the Northam Airport unless the express permission of the Shire of Northam Council has been granted. Northam Aero Club representatives have indicated that these rules were implemented as a result of a number of complaints received in relation to noise and the low flying nature of these aircrafts.

Minute No C.526

Moved Cr R W Tinetti, Seconded Cr G N Beazley

- 8) **That in recognition of the work undertaken by the NAC in developing the Northam Airport, Council grant it rent free status for the proposed lease of their clubroom and adjoining hanger on site 21 for the term of 15 years, commencing 1 July 2008 subject to the site not being used for any commercially based activity.**
- 9) **That Council present to the NAC, at a suitable function in the NAC clubrooms, a plaque that recognises the contribution made by the NAC to the development of the Northam Airport.**
10. **That Council adopt the 'Northam Airport Rules of Operation' listed in Schedule 12.**
11. **That Council grant FESA rent free status and a rate concession for site 20 due to its use as an emergency water supply for fire fighting.**

**CARRIED 8/0
BY ABSOLUTE MAJORITY VOTE**

SCHEDULE 12

NORTHAM AIRPORT RULES OF OPERATION

The Shire of Northam has appointed the Northam Aero Club Inc as the Managing Body for the Northam Airport.

The Northam Aero Club has appointed a person, approved by Council, who is the designated Airport Manager.

The Airport Manager has the responsibility for making those decisions necessary to manage the day to day operations of the airport.

Every person who enters the Airport site must comply with the following rules.

RULES

1. Any person using or entering the Northam Airport site must at all times comply with any lawful request or direction of the Airport Manager
2. All aircraft using/operating from the Northam Airport shall do so in accordance with Civil Aviation Safety Regulations
3. Night circuits by any aircraft are not permitted after 2100 hrs Western Standard Time (1300 UTC). This rule does not apply to aircraft terminating or originating a night flight in Northam.
4. In order that aircraft noise levels over the town are minimised, left hand circuits are applied to Runway 14. Right hand circuits are applied to Runway 32.

5. The following types of aircraft are not permitted to operate from the Northam Airport unless the express permission of the Northam Shire Council has been granted.
 - a) Gyroplanes CAO 95.12 and CAO 95.12.1
 - b) Weight shift Control aircraft and Powered Parachutes. CAO 95.32
 - c) Parasails and Gyroglides CAO 95.14
6. All aircraft not contained within an approved hangar must be parked in the designated aircraft parking area.
7. Security of any aircraft is at all times the responsibility of the individual owner or operator or Pilot in Command (PIC).
8. Motor vehicle entry to the Airport site must be through the approved entry gate off Withers Street.
9. Motor vehicles (including tugs) entering the Northam Airport site must not proceed beyond the nominated general vehicle parking area unless specific approval has been granted by the Airport Manager.
10. Application for vehicle access to the airport beyond the General Parking area should in the first instance be made to the Airport Manager and may be granted subject to conditions.

Any Vehicle access approval granted is subject to the approved vehicle meeting the safety and licensing regulations applicable to all general road usage.

Where the vehicle is an aircraft tug it shall be certified as safe to use for that purpose by a person competent to do so.
11. Notwithstanding any vehicle access approval granted under Rule 10, vehicles shall not be permitted on the airport runway unless specifically approved to do so by the Airport Manager. Such vehicles must be equipped with suitable flashing warning lights preferably a working air-band radio, and driven by a driver who is trained in or aware of airport safety requirements or be accompanied by a person approved by the Airport Manager.
12. The maximum speed for any motor vehicle on the Northam Airport site is 40 km per hour.
13. Access to the Airport especially airside by persons.
 - 13.1 No person may enter the Northam Airport site other than through the approved entry gate off Withers Street and may not move beyond the General Vehicle Parking area unless accompanied by:
 - (a) A representative of the Shire of Northam; or
 - (b) A representative of the Airport Manager; or
 - (c) A Lessee or the appointed representative of a Lessee of any hangar site at the Airport; or
 - (d) Has been specifically authorised to do so by virtue of being an employee of any Lessee operating a business from a hangar site.

- 13.2 (a) *Notwithstanding sub clause 13.1 where an aircraft lands at the Northam Airport to either pick up or drop off passengers then the Pilot in Command (PIC) of that aircraft will be responsible for the safety of his passengers.*
- (b) *The PIC will escort incoming passengers from his aircraft to the general vehicle parking area or into the care of one of those persons authorised in sub clause 13.1(a) to (c) inclusive.*
- (c) *The PIC will escort outgoing passengers either from the general vehicle parking area to his aircraft or where these passengers are already in the care of a person authorised by sub clause 13.1(a) to (c) inclusive from the care of those persons to his aircraft.*
14. *Only persons authorised by the Airport Manager may enter onto the Northam Airport runway.*
15. *With authority from the Airport Manager access to the Northam airport site is permitted at any time by Emergency Service vehicles or personnel attending to any emergency. Care must be taken not to conflict with aircraft that may be using the Airport.*

A request has been received from a Shire of Northam resident and business owner seeking permission to operate their gyrocopter from the Northam Airport and construct a hangar to enable this to be based on site. The applicant has been involved in aviation for a number of years, including flight training from the Northam Aero Club and then proceeded to learn to fly Gyrocopters in York at WhiteGum Airpark.

WhiteGum Farm is a fully functioning private air park with ultralight and gyrocopter aircraft flying schools. It is the largest, privately owned flight facility in Western Australia, with hangaring facilities for microlight and ultralight aircraft. [A gyrocopter flight video can be viewed here.](#)

B. CONSIDERATIONS

B.1 Strategic Community / Corporate Business Plan

Performance Area: Prosperity.

Outcome 10: An attractive destination for investors, business and visitors; helping to grow the economy and local jobs.

Objective 10.1: Pursue economic growth, innovation and diversification.

Priority Action 10.1.5: Provide upgraded infrastructure at the Northam Airport to provide opportunities for expansion.

B.2 Financial / Resource Implications

Should Council grant permission, Council would receive the below revenue:

- \$990 lease fees (annually);

- \$1,000 approx. Shire rates (annually); and
- \$3,555 lease establishment fee (one off).

The applicant has indicated that they would be able to construct a hangar on site 2, 6 or 11. These sites have been marked as unusable due to the hangar set back requirements of 1.5m from each side (*Local Planning Policy 9 – Northam Airport Development*). This set back limits the width of the hangar to 12m which is unsuitable for most aircrafts as generally a minimum of 15m width is required. This is an advantageous consideration factor as it would allow development on a site that would otherwise not be developed.

CASA 'Certified' airport means that all aircraft must be equipped with radios. As Northam is a CASA 'Non Certified' airport, aircraft radios are not mandatory and as such should permission be granted, a new rule is proposed to mandate the use of radios. This would result in expenditure to update the signage at the Northam Airport and may also result in expenditure for current airport users needing to fit their aircrafts with radios.

Officers explored becoming a CASA 'Certified' airport which would impose additional requirements such as developing an Aerodrome manual, appointing certain persons responsible for aeronautical information and any other conditions determined by CASA. A cost estimate to become a 'certified' airport will not be provided by CASA until an application has been made to become a 'certified' airport.

B.3 Legislative Compliance

The Civil Aviation Regulations 1988 (CAR) and Civil Aviation Safety Regulations 1998 (CASR) are the regulatory controls for aviation safety in Australia. They contain the detailed safety standards that people and organisations must comply with. The CASR are typically grouped around a foundation, such as flight operations.

In Australia, gyrocopters operate under similar CASA regulations as do other recreational aircraft. Under CASA CAO 95.12 & 12.1, gyrocopters are classified as an ultralight with a maximum flying altitude of 500ft Above Ground Level (AGL) unless the pilot holds a specific endorsement. Gyrocopters may also legally operate at a minimum altitude of 300ft AGL and even lower with the permission of the landowner. A standard gyrocopter circuit is executed at 500ft AGL. Other than these differences, gyrocopters operate under the same CASA regulations as other ultralights. Gyrocopter operations are not permitted inside controlled airspace.

B.4 Policy Implications

Airport Masterplan

The Shire of Northam Airport Masterplan was adopted in 2015 and is due for review. More recently developed Airport Masterplans such as the Shire of Dandaragan's (Jurien Bay Airport) examine the trends towards light sports aircrafts identifying that that the future of aviation will change markedly due to the cost benefit of owning and running a light sports aircraft. Types of aircraft that may satisfy these criteria are 3-axis aeroplanes, powered parachutes, weight-shift control aeroplanes (trikes), gliders, balloons, airships and gyroplanes.

B.5 Stakeholder Engagement / Consultation

Officers have sought comment from the Northam Aero Club as Managers of the Northam Airport. No objections were raised in relation to the application subject to the operator adhering to traffic regulations.

Officers have sought information from other regional airports such as Shire of Derby / West Kimberley, Shire of Dandaragan, Shire of Manjimup and the City of Bunbury. All of these airports permit the use of gyrocopters however this has had limited testing at these facilities with the exception of Bunbury.

Gyrocopters have been operating from Bunbury Airport for 20 years. The City of Bunbury have outlined that there was initial opposition from aircraft owners about sharing the airspace with slower moving gyrocopters. This was resolved by having aircraft undertake circuits at 1,000ft with gyrocopters and microlights undertaking circuits at 500ft. All parties now get along well and the City of Bunbury is not aware of any current ill-will between the various users. Bunbury Airport is surrounded by bush areas and Gyrocopters are able to undertake tight circuits which results in them mainly flying over these areas. Aircraft (Cessna's etc.) undertaking circuits fly a wider circuit pattern which results in the flying over residential areas.

It is understood that gyrocopters were initially restricted from operating at the Northam Airport due to the number of complaints received from residents in relation to low flying over residences and noise. No consultation has occurred with the broader community in relation to this matter. The 'Airport Operator' (i.e. Shire of Northam) is responsible for the safe maintenance of the airport. However, the Shire's control of aircraft ceases once the pilot closes the last aircraft door or when the aircraft starts moving under its own power. Complaints about low flying aircraft are dealt with by the Civil Aviation Safety Authority (CASA) rather than the 'airport owner' and similarly aircraft noise complaints are dealt with by Airservices rather than the 'airport owner'. Officers recognise that local

residents may still complain to the Shire of Northam however this is technically not a Local Government issue.

B.6 Risk Implications

Risk Category	Description	Rating (likelihood x consequence)	Mitigation Action
Financial	Loss of revenue from lessees resulting in lack of development at the Northam Airport.	Possible (3) x Medium (3) = Moderate (9)	Actively promote Northam Airport as a destination for recreation aircraft operators.
Health & Safety	Mid-air collision.	Possible (3) x Extreme (5) = High (15)	Mandate the carriage and use of air-band radios to reduce the potential of mid-air collision.
Reputation	Damage to reputation as a result of granting permission to the gyrocopter operator and amending the rules of operation.	Possible (3) x Minor (2) = Moderate (6)	Ensure that Council's decision is communicated to the Northam Aero Club to ensure that the lessees are aware of the updated rules of operation. The Northam Aero Club is responsible for the day-to-day operations of the Northam Airport and oversees the leased portions of land to the lessees.
Service Interruption	Nil.		
Compliance	Nil.		
Property	Nil.		
Environment	Nil.		

B.7 Natural Environment Considerations

Nil.

C. OFFICER'S COMMENT

Officers are of the view that the gyrocopter operating from the Northam Airport can be effectively managed with the appropriate conditions in place.

RECOMMENDATION / COUNCIL DECISION

Minute No: C.4689

Moved: Cr A J Mencshelyi

Seconded: Cr M P Ryan

That Council:

- 1. Grant permission to Corry Munson to operate a gyrocopter (registration No. G1829) from the Northam Airport, subject to the following conditions:
 - a. A lease being entered into for the development of a hangar on site 2, 6 or 11.**
 - b. The operator adhering to the Northam Airport Rules of Operation and Civil Aviation Safety Authority (CASA) traffic regulations and Advisory Circulars.**
 - c. The operator undertaking circuits at 500ft Above Ground Level.**
 - d. The operator undertaking a maximum flying altitude of 500ft Above Ground Level and a minimum flying altitude of 300ft Above ground Level unless the express permission of the landowner has been provided.**
 - e. The operator is prohibited from operating over private residences without express permission from the landowners.**
 - f. This permission may be revoked in the event of non-compliance with the above conditions.****
- 2. Amend the rules of operations to mandate the carriage and use of air-band radios for all users of the Northam Airport.**
- 3. Include a standard entry in the En Route Supplement Australia (ERSA) Facilities (FAC) under Local Traffic Regulations that 'Carriage and use of radio is required by Aerodrome Operator (AD OPR)'.**

CARRIED 8/0

One Member of the gallery, Mr C Munson, left the meeting at 5:48pm.



Errol Croft
President
Northam Aero Club
PO Box 247
NORTHAM WA 6401

Our ref: A12838/O79459
Enquiries: Alysha Mccall

Dear Mr Croft

GYROCOPTER REQUEST NORTHAM AIRPORT

The Shire of Northam has received a request to construct a hangar and operate a gyrocopter at the Northam Airport (Airport). The current rules of operation do not permit this type of aircraft to operate from the Airport unless the express permission of the Shire of Northam has been granted. The Shire of Northam is seeking a formal response from the Northam Aero Club as Managers of the Airport to enable a report to be presented to Council to determine the application.

Please see below information provided by the applicant:

The applicant owns and operates a business in Northam and also resides within the Shire. This application has been made due to the Northam Airports proximity to the applicants home and business, in addition to wanting to use a tarmac runway. The applicant has been involved in aviation for some time, including flight training from the Northam Aero Club but decided on a different avenue than the aircraft type they were training in at Northam. They then proceeded to learn to fly Gyrocopters and was taught in York at Whitegum Airpark.

The applicant believes that the gyrocopter has developed a bad reputation in the early years as many were poorly homebuilt and suffered many crashes due to insufficient pilot training or mechanical failure. The Gyrocopter owned and operated by the applicant is a factory-built aircraft from Italy, these factory-built aircraft are certified in many countries and use the common engines in many small planes including many based in Northam and indeed the world aviation community.

An image of the proposed aircraft (Magni M24 Orion Gyrocopter) is provided below:



ABN 42 826 617 380
395 Fitzgerald Street - PO Box 613, Northam WA 6401
T (08) 9622 6100
E records@northam.wa.gov.au W www.northam.wa.gov.au

The following responses have been provided by the applicant addressing common concerns with respect to this type of aircraft:

Noise

The proposed aircraft uses a common engine which is also used among the majority of light aircraft in Australia which is a factory-built Rotax 914, this is also considerably less noisy than many of the larger commercial aircraft currently being flown from the Northam Airport on a regular basis.

Slower speed and lower flight circuit

This is true to a certain degree but like any safe pilot the applicant has advised that they can adapt their circuit height to suit whatever airport they fly at, aircraft in circuit at Northam operate at 1000ft circuit height and the applicant can do the same to fit in with other aircraft as required, also the applicant can conduct thier flight speed during circuits at 70 knots if required to match the majority of light aircraft until final approach and will land at 55 knots (this speed is similar to most light aircraft coming in to land).

Should permission be granted, a range of conditions are recommended to be imposed, this may include:

- Restrictions on circuit heights: Research among other Airports such as Bunbury indicates that the varying types of aircraft are effectively managed by restricting gyrocopter circuit heights at 500ft and 1,000ft for other aircraft.
- Mandating the carriage and use of air-band radios: This may include becoming a CASA certified airport and/or amending the rules of operation to make the carriage and use of air-band radios mandatory to reduce the potential of mid-air collision.
- Restrictions on low flying over residences: It should be noted that the 'Airport Operator' (i.e. Shire of Northam) is responsible for the safe maintenance of the airport however the Shire's control of the aircraft ceases once the pilot closes the last aircraft door or when the aircraft starts moving under its own power. Although conditions may be placed on the approval, complaints about low flying aircraft are dealt with by CASA rather than the 'airport operator' and similarly aircraft noise complaints are dealt with by Airservices rather than the 'airport operator'.

Please note that it is not the intent to amend the rules of operation to allow gyrocopters to operate from the airport. Any future gyrocopter operators would be required to apply for approval and will be determined by Council on a case-by-case basis.

It would be appreciated if a response can be provided by no later than **17 February 2023**.

Should you have any queries with regard to this matter please contact Mrs Alysha McCall, Acting Governance Coordinator on eaceo@northam.wa.gov.au or (08) 9622 6114.

Yours faithfully



CHADD HUNT
ACTING CHIEF EXECUTIVE OFFICER

CH:AM

27 January 2023

Ordinary Council Meeting Minutes 15 March 2023

Attachment 13.1.3.3

From: Errol Croft <dowref@bigpond.net.au>
Sent: Saturday, 18 February 2023 9:27 AM
To: Alysha McCall <eaceo@northam.wa.gov.au>
Subject: RE: GYROCOPTER REQUEST NORTHAM AIRPORT

Good morning Alysha,

My apologies for not getting back to you sooner. We had our meeting on 5th February and our Secretary was not in attendance, I have put together the Minutes and have included as follows:

- Letter from Alyssa at Shire of Northam advising of application by gyrocopter pilot who is wanting to build hangar at Northam Airfield and asking us for any objections.
Action – Motion by Dave Beech, seconded Trevor Sangston that the Aero Club has no objection in the application subject to adherence of local traffic regulations of the Airfield. CARRIED.

Therefore the Northam Aero Club has no objection to the application subject to adherence of local traffic regulations of the Airfield.

Please contact me if you require further discussion.

Regards,

Errol Croft
PRESIDENT
Northam Aero Club
PH: 0428 880 149 FAX: 08 9629 1754

13.1.4 Review of Governance Policies

File Reference:	2.3.1.2
Reporting Officer:	Alysha McCall (Governance Coordinator)
Responsible Officer:	Jason Whiteaker (Chief Executive Officer)
Officer Declaration of Interest:	Nil
Voting Requirement:	Simple Majority Absolute Majority
Press release to be issued:	No

BRIEF

For Council to review its governance policies.

ATTACHMENTS

1. G 1.1 Council Members - Continuing Professional Development (AMENDED) [**13.1.4.1** - 3 pages]
2. G 1.2 Attendance at Events - Council Members and the CEO (AMENDED) [**13.1.4.2** - 4 pages]
3. G 1.3 Attendance at Events - Chief Executive Officer (REVOKE) [**13.1.4.3** - 3 pages]
4. G 1.4 Code of Conduct for Councillors, Committee Members and Candidates (NO CHANGE) [**13.1.4.4** - 11 pages]
5. G 1.5 Legal Representation for Council Members and Employees (NO CHANGE) [**13.1.4.5** - 6 pages]
6. G 1.6 Approval of annual and long service leave for the CEO and appointment of an A/CEO (AMENDED) [**13.1.4.6** - 4 pages]
7. G 1.7 Senior Employees (NO CHANGE) [**13.1.4.7** - 1 page]
8. G 1.8 Risk Management (NO CHANGE) [**13.1.4.8** - 6 pages]
9. G 1.9 Council Member and Staff Interactions and Requests for Information (AMENDED) [**13.1.4.9** - 3 pages]
10. G 1.10 Communications and Social Media Policy (AMENDED) [**13.1.4.10** - 6 pages]
11. G 1.11 Corporate Uniform - Council Members (NO CHANGE) [**13.1.4.11** - 1 page]
12. G 1.16 Acceptable Use of the Shire's Computing and Communication Resource (AMENDED) [**13.1.4.12** - 2 pages]
13. G 1.17 Acceptable Use of the Shire's Computing and Communication Resources - Staff (REVOKE) [**13.1.4.13** - 2 pages]
14. G 1.19 Public Interest Disclosure (NO CHANGE) [**13.1.4.14** - 2 pages]
15. G 1.20 Organisational Structure (NO CHANGE) [**13.1.4.15** - 2 pages]
16. G. 1.21 Elected Members Leave of Absence (NEW POLICY) [**13.1.4.16** - 2 pages]

17. A 8.3 Records Management (AMENDED) [13.1.4.17 - 3 pages]
18. A 8.4 Complaints Management (AMENDED) [13.1.4.18 - 4 pages]
19. A 8.5 Property Management (Leases and Licences) (AMENDED) [13.1.4.19 - 11 pages]

A. BACKGROUND / DETAILS

An elected member workshop was held on 22 February 2023 to allow detailed discussions and input into Council's existing and proposed governance policies. The following table details the policies to be reviewed and the proposed major changes being presented to Council for consideration.

Policy No.	Policy Title	Comment / Changes
G 1.1	Council Members - Continuing Professional Development	Updated part 2 to align with recently adopted Council Plan.
G 1.2	Attendance at Events - Council Members	Updated to incorporate the CEO. Updated headings to ensure consistency with policy template. This includes adding a scope and merging objective/purpose. Added a section for definitions, distribution of tickets and exemptions.
G 1.3	Attendance at Events - Chief Executive Officer	Revoked and merged with policy G 1.2.
G 1.4	Code of Conduct for Councillors, Committee Members and Candidates	No change as the current Code is consistent with the <i>Local Government (Model Code of Conduct) Regulations 2021</i> .
G 1.5	Legal Representation for Council Members and Employees	No change.
G 1.6	Approval of annual and long service leave for the CEO and appointment of an Acting CEO	Updated to WALGA Policy template.
G 1.7	Senior Employees	No change.
G 1.8	Risk Management	No change.
G 1.9	Council Member and Staff Interactions and Requests for Information	Updated terminology.

		Updated Corporate Business / Strategic Council Plan reference.
G 1.10	Communications and Social Media Policy	Minor formatting and typographical adjustments. Updated methods of communication. Removed COVID-19 group as this is not relevant to social media accounts. Included a comment in relation to any other social media accounts as approved by the CEO.
G 1.11	Corporate Uniform – Council Members	No change.
G 1.12	No Smoking	
G 1.13	Alcohol Consumption	
G 1.14	Gratuity, Gifts and Departing Employees	
G 1.16	Acceptable Use of the Shire's Computing and Communication Resource - Council Members	Changed terminology to ICT. Moved scope from policy to scope. Added additional items to prohibited use. Expanded on consequences for non-compliance with this policy, i.e. may result in disciplinary action.
G 1.17	Acceptable Use of the Shire's Computing and Communication Resources - Staff	Revoke as the policy detail has been included in the code of conduct for staff.
G 1.18	Credit Card Use	
G 1.19	Public Interest Disclosure	No change.
G 1.20	Organisational Structure	No change.
G TBC	Elected Members Leave of Absence	New policy as requested at the Strategic Council Meeting held on 23 November 2022.
A 8.3	Records Management	Updated legislation reference and related Shire documents.
A 8.4	Complaints Management System Policy	Added a scope. Included principles of complaint management to align with Ombudsman WA

		and that a process be developed to meet the principles within the policy.
A 8.5	Management of Council Property Leases	Major review.
A 8.6	Consent to Consume Liquor in or on a Council Property (Public Place)	No change.

B. CONSIDERATIONS

B.1 Strategic Community / Corporate Business Plan

Performance Area: Performance.

Outcome 12: Excellence in organisational performance and customer service.

Objective 12.1: Maintain a high standard of corporate governance and financial management.

Priority Action: Nil.

Performance Area: Performance.

Outcome 12: Excellence in organisational performance and customer service.

Objective 12.2: Be an innovative and efficient organisation that provides outstanding customer services.

Priority Action: Nil.

B.2 Financial / Resource Implications

Nil.

B.3 Legislative Compliance

Various policies are required by the Local Government Act 1995, including:

- 5.90A - Policy for attendance at events
- 5.50 - Payments to employees in addition to contract or award (gratuity & gifts)
- 5.103 - Codes of conduct
- 5.128 – Continuing professional development

B.4 Policy Implications

Various.

B.5 Stakeholder Engagement / Consultation

A workshop was held with Elected Members on 22 February 2023.

The following items were discussed:

- G1.1 - Council Members - Continuing Professional Development
 - A reference to be included for conferences to better link this with policy G 1.2 – Attendance at Events. This has been included in the draft policy.
- G1.2 – Attendance at Events - Council Members and the Chief Executive Officer
 - Inclusion of events held by Local Government Professionals as an approved event. This has been included in the draft policy.
 - Expenses relating to spouses are to be reimbursed to the local government. This has been included in the draft policy.
 - The approval process for attending non-approved events for the Shire President. The new policy details that these will be approved by the Deputy President. Upon undertaking further research, many local governments allow the Chief Executive Officer to approve the Presidents attendance and the President approves Councillors and the Chief Executive Officers attendance. This update has been made in the draft policy.
 - Including a section for reporting to Council where expenses are applicable for attendance at an event. This has been included in the draft policy.
 - Including that any event where flights are associated with the attendance and are paid by the local government is a non-approved event. This has been included in the draft policy.
- G 1.6 - Approval of annual and long service leave for the CEO and appointment of an Acting CEO
 - Removing reference to the line of succession in the event that the CEO is unavailable or unable to make the decision to appoint an Acting CEO. This has been included in the draft policy.
 - It was queried whether appointing a CEO must be undertaken by simple or absolute majority. This has been confirmed as requiring a decision by absolute majority.
 - Whether the clause reference under 2(b) is for the Act. This has been updated to reference the correct clause within the policy.
- G 1.9 - Council Member and Staff Interactions and Requests for Information
 - It was requested that the terminology referring to Council Members include Committee Members to ensure consistency. This has been included in the draft policy.
- G 1.10 - Communications and Social Media Policy
 - Where it referenced the Shire's social media accounts, it was requested to include a comment in relation to any other accounts approved by the Chief Executive Officer. This has been included in the draft policy.
- G 1.16 - Acceptable Use of the Shire's Computing and Communication Resource - Council Members

- Clarification was sought in relation to accessing data, a server or an account for any purpose other than conducting Shire business, even if the Elected Member has authorised access. This relates to accessing *Shire* data, servers or accounts for any other purpose than conducting Shire business. The word 'Shire' has been added to ensure that it relates to Shire data, servers and accounts.
- Discussion was held in relation to non-compliances with this policy and wording to be reviewed. This has been updated in the draft policy to reference disciplinary action in accordance with Council's Code of Conduct.
- Elected Members Leave of Absence (new policy)
 - Clarification was sought in relation to whether Council can not pay Elected Members when long period of leave are granted. It was advised that as Council set an annual fee as opposed to a meeting fee it is not believed that a portion of the annual fee cannot be withheld. This has been confirmed by the Department of Local Government.
 - Discussion was held around developing a leave of absence form to ensure all requirements are captured. This could be included on the Councillor Portal. Officers confirmed that this will be developed once the policy has been adopted by Council.
 - Clarification was sought in relation to whether a clause can be included requiring leave to be approved in advance (i.e. leave cannot be approved at a meeting for which the leave relates). This has been included in the draft policy.
- A 8.4 - Complaints Management System Policy
 - Minor typographical adjustments were identified and corrected.
- A 8.5 – Property Management (Leases and Licences)
 - Clarification was sought in relation to the reason for the Northam Memorial Hall being excluded from the section relating to community halls. This hall has a Deed of Agreement in place whereby it is managed by a Board of Management that comprises of members from the Shire and the various users of the facility. This Deed is in place to comply with the conditions which applied to the sale of land in 1975 to the Shire of Northam from the Returned & Services League WA Branch. The current Deed of Agreement does not have an expiry date and is current until terminated upon agreement of all parties.

B.6 Risk Implications

Risk Category	Description	Rating (likelihood x consequence)	Mitigation Action
Financial	N/A		

Health & Safety	N/A		
Reputation	Council not viewed as being transparent as a result of inadequate policies	Possible (3) x Minor (2) = Moderate (6)	Adopt policies as per recommendation. Publish policy manual on Council website
Service Interruption	N/A		
Compliance	Non-compliance with LG Act requirements	Possible (3) x Minor (2) = Moderate (6)	Adopt policies referenced in section B.3 of officer report
Property	N/A		
Environment	N/A		

B.7 Natural Environment Considerations

Nil.

C. OFFICER'S COMMENT

Nil.

RECOMMENDATION / COUNCIL DECISION

Minute No: C.4690

Moved: Cr H J Appleton

Seconded: Cr D J Galloway

That Council:

- 1. Adopts the following polices as amended and authorises the Chief Executive Officer to make the necessary adjustments to the Shire of Northam Policy Manual:**
 - a. G 1.9 Council Member and Staff Interactions and Requests for Information;**
 - b. G 1.10 Communications and Social Media Policy;**
 - c. G 1.16 Acceptable Use of the Shire's Computing and Communication Resource - Council Members;**
 - d. G 1.21 Elected Members Leave of Absence**
 - e. A 8.3 Records Management**
 - f. A 8.4 Complaints Management**
 - g. A 8.5 Property Management (Leases and Licences)**
- 2. Revoke policy G 1.17 Acceptable Use of the Shire's Computing and Communication Resources - Staff**

CARRIED 8/0

RECOMMENDATION / COUNCIL DECISION

Minute No: C.4691

Moved: Cr M P Ryan

Seconded: Cr A J Mencshelyi

That Council:

- 1. Adopts the following polices as amended and authorises the Chief Executive Officer to make administrative adjustments to the Shire of Northam Policy Manual:**
 - G 1.1 Council Members - Continuing Professional Development**
 - G 1.2 Attendance at Events - Council Members and the Chief Executive Officer**
 - G 1.6 Approval of annual and long service leave for the CEO and appointment of an Acting CEO**
- 2. Revoke Policy G 1.3 Attendance at Events – Chief Executive Officer.**

**BY ABSOLUTE MAJORITY
CARRIED 8/0**



GOVERNANCE

G 1.1 Council Members - Continuing Professional Development

<i>Responsible Department</i>	Chief Executive Officer
<i>Resolution Number</i>	TBC
<i>Resolution Date</i>	TBC
<i>Next Scheduled Review</i>	2024
<i>Related Shire Documents</i>	
<i>Related Legislation</i>	<i>Local Government Act 1995 s5.128</i>

OBJECTIVE

The *Local Government Act 1995* requires all Council Members to undertake compulsory training within 12 months of being elected. The Shire of Northam is required under the *Local Government Act 1995* to adopt and report on compulsory training and continuing professional development for Council Members of the Shire of Northam.

SCOPE

This policy applies to Council Members of the Shire of Northam (Shire).

POLICY

The Policy consists of three parts which have distinct obligations.

'Part 1: Mandatory Council Member Training' sets out the legislative requirements that newly elected Council Members must undertake Compulsory Council Member Training. Newly elected Council Members who complete the Compulsory Council Member Training are deemed to have met their Continuing Professional Development (CPD) requirements under Part 2 for the first two years of their term.

'Part 2: Continuing Professional Development' requires Council Members to undertake CPD as determined by Council. This applies to all Council Members. However, newly elected Council Members who undertake the Compulsory Council Member Training under Part 1 are deemed to have met their Continuing Professional Development requirements for the first two years of their term.

'Part 3: Reporting' sets out the reporting requirements under the *Local Government Act 1995*.



Part 1 Mandatory Council Member Training

Council Members of the Shire of Northam have significant and complex roles that require a diverse skillset.

All Council Members elected to Council following the 2019 election are required under the *Local Government Act 1995* to complete the Council Member Essentials Course, unless they meet limited exemptions. The training is valid for five years so a Council Member is only required to undertake the training at every second election. The course must be completed within 12 months of appointment to Council.

1.1 Cost of Training

The Council Member Essentials Course will be sourced by the Shire of Northam at no cost to Council Members.

Part 2 Continuing Professional Development

Continuing Professional Development (CPD) opportunities will be provided to the Shire of Northam Council Members.

The opportunities will be in line with the strategic direction of the Shire of Northam:

- People;
- Planet;
- Place;
- Prosperity; and
- Performance.

Elected Members may attend professional development opportunities of their choice that supports their role as an Elected Member. Professional development can take several forms including formal qualifications, short-courses, seminars and conferences. Training paid for in accordance with this policy must have benefit to Council, the Shire and the community.

In accordance with Section 5.90A of the *Local Government Act 1995*, the definition of an event includes conferences. Council policy G 1.2 Attendance at Events – Council Members and the Chief Executive Officer governs attendance at conferences which may contribute to the professional development of an Elected Member.

2.1 CPD Hours

Each Council Member elected after 2019 must complete 10 CPD hours every two years from ordinary election to ordinary election.

The Shire of Northam will organise training sessions that meet the intent of the policy where all Council Members are invited to attend to meet their obligations as a Council group at the Shire of Northam.



Shire of Northam Policy Manual (Section I)
Policy
G 1.1 Council Member Continuing Professional Development

All training will be funded by the Shire of Northam at no cost to Council Members.

Part 3 Reporting

The Shire of Northam is required to report annually on completed training. Completed training must be published on the Shire of Northam website for that financial year. This will include the Council Member Essentials Course and any continuing professional development undertaken by Council Members.



GOVERNANCE

G 1.2 Attendance at Events - Council Members and the Chief Executive Officer

<i>Responsible Department</i>	Chief Executive Officer
<i>Resolution Number</i>	TBC
<i>Resolution Date</i>	TBC
<i>Next Scheduled Review</i>	2025
<i>Related Shire Documents</i>	
<i>Related Legislation</i>	Local Government Act 1995 s5.90A Local Government (Administration) Regulations 1996

OBJECTIVE

The Shire of Northam is required under the Local Government Act 1995 (the Act) to adopt a policy to govern the attendance at events for Elected Members and the Chief Executive Officer. The purpose of this policy is to outline the process associated with attendance at an event in accordance with section 5.90A of the Act.

Attendance at an event in accordance with this policy will exclude the gift holder from the requirement to disclose an interest if the ticket is above \$300 and the donor has a matter before council. Any gift received that is less than \$300 (either one gift or cumulative over 12 months from the same donor) also does not need to be disclosed as an interest. Where the value of the ticket exceeds \$300, receipt of the gift will still be required under the gift register provisions.

SCOPE

This policy applies to Elected Members and the Chief Executive Officer of the Shire of Northam (the Shire).

POLICY

In accordance with Section 5.90A of the *Local Government Act 1995* an event is defined as:

- (a) a concert;
- (b) a conference;
- (c) a function;
- (d) a sporting event; or



(e) an occasion of a kind prescribed for the purposes of this definition.

Elected Members and the Chief Executive Officer attend events to fulfil their leadership role in the community. Elected Members and/or the Chief Executive Officer may receive tickets or invitations to attend events to represent the Shire. The event may be a paid event or a ticket/invitation may be gifted in kind.

1. Pre-Approved Events

In order to meet the policy requirements, tickets and invitations to events must be received by the Shire.

The Shire approves attendance at the events listed in Appendix A by Elected Members and the Chief Executive Officer.

All Elected Members and the Chief Executive Officer are entitled to attend pre-approved events. If there is a fee associated with a pre-approved event, the fee will be paid for by the Shire out of the Shire's budget (either beforehand or by way of reimbursement), unless the event is a conference which is dealt with under clause 4 of this policy.

If there are more Elected Members than tickets provided then the President shall allocate the tickets.

2. Approval Process

Where an invitation is received to an event that is not pre-approved, it may be submitted for approval no later than three business days prior to the event for approval as follows:

- Events for the President will be approved by the Chief Executive Officer;
- Events for Councillors, the Deputy President and the Chief Executive Officer will be approved by the President.

Considerations for approval of the event include:

- Any justification provided by the applicant when the event is submitted for approval;
- The benefit to the Shire of the person attending;
- Alignment to the Shire's Strategic Objectives; and
- The number of Shire representatives already approved to attend.

Where an Elected Member or Chief Executive Officer have an event approved through this process and there is a fee associated with the event, then the cost of the event will be paid out of the Shire's budget (either beforehand or by way of reimbursement), unless the event is a conference which is dealt with under clause 4 of this policy.



Where partners of an Elected Member or Chief Executive Officer attend an event, any ticket for that person, if paid by the local government, must be reimbursed by the Elected Member or Chief Executive Officer unless expressly authorised by Council.

3. Non-Approved Events

Any event that is not pre-approved, is not submitted through an approval process, or is received personally is considered a non-approved event.

If the event is a free event to the public then no action is required.

If the event is ticketed and the Elected Member or Chief Executive Officer pays the full ticketed price and does not seek reimbursement then no action is required.

If the event is ticketed and the Elected Member or Chief Executive Officer pays a discounted rate or is provided with a free ticket then the recipient must disclose receipt of the tickets (and any other associated hospitality) within 10 days.

Any event where flights are associated with the attendance and are to be paid by the local government is a non-approved event.

4. Conferences

The Shire supports Elected Members and the Chief Executive Officer in attending conferences. Conferences encourage development and networking opportunities. Council policy Council Members - Continuing Professional Development governs conference entitlements.

5. Dispute Resolution

Any disputes under this policy are to be resolved by the President.

6. Reporting

Where attendance at an event is paid by the local government, the Council Member or Chief Executive Officer must report to Council on the benefit of attending the event.

APPENDIX A – Events Authorised in Advance (subject to available budgets)

- a. Advocacy lobbying or ministerial briefings
- b. Meetings of clubs or organisations within the Shire of Northam
- c. Any free event held within the Shire of Northam
- d. West Australian-based local government events (such as WA Local Government Week)



*Shire of Northam Policy Manual (Section I)
Policy
G 1.2 Attendance at Events – Council Members and the Chief
Executive Officer*

- e. Events hosted by clubs or not-for-profit organisations within the Shire of Northam to which the Council Member has been officially invited
- f. Shire of Northam hosted events, ceremonies and functions
- g. Local Community art exhibitions
- h. Shire of Northam local cultural events/festivals
- i. Events run by a local, state or federal government
- j. Events run by schools and universities within the Shire of Northam
- k. Opening or launch of an event or facility within the Shire of Northam
- l. Events where President or Chief Executive Officer representation has been formally requested
- m. Major professional bodies associated with local government at a local, state and federal level
- n. Events hosted by Local Government Professionals
- o. Events hosted by Regional Capitals Alliance Western Australia (subject to available budget)

The above events are excluded where flights are associated with the attendance and are to be paid by the local government.

APPENDIX B – Specific Event Approvals

Event	Date of Event if known	Approved attendee	Approved local government contribution	Date of Council resolution



Shire of Northam Policy Manual (Section I)
Policy

G 1.3 Attendance by the Chief Executive Officer at Events

GOVERNANCE

G 1.3 Attendance by the Chief Executive Officer at Events

<i>Responsible Department</i>	Chief Executive Officer
<i>Resolution Number</i>	C.4081
<i>Resolution Date</i>	18/11/2020
<i>Next Scheduled Review</i>	2022
<i>Related Shire Documents</i>	
<i>Related Legislation</i>	Local Government Act 1995 s5.90A

OBJECTIVE

To establish standards for the attendance of the Chief Executive Officer at both intrastate and interstate conferences and the reimbursement of expenses incurred during those attendances (as required by section 5.90A of the *Local Government Act 1995*).

PURPOSE

This policy addresses attendance at any events, including concerts, conferences, functions or sporting events, whether free of charge, part of a sponsorship agreement, or paid by the local government. The purpose of the policy is to provide transparency about the attendance at events of the Chief Executive Officer (CEO).

Attendance at an event in accordance with this policy will exclude the gift holder from the requirement to disclose an interest if the ticket is above \$300 and the donor has a matter before Council. Any gift received that is less than \$300 (either one gift or cumulative over 12 months from the same donor) also does not need to be disclosed as an interest. Receipt of the gift will still be required under the gift register provisions.

LEGISLATION

Local Government Act 1995 - 5.90A, policy for attendance at events, defines an event as being:

- (a) a concert;
- (b) a conference;
- (c) a function;
- (d) a sporting event; or
- (e) an occasion of a kind prescribed for the purposes of this definition.



PROVISION OF TICKETS TO EVENTS

1. Invitations

- a. All invitations or offers of tickets for the CEO to attend an event should be in writing and addressed to the Shire of Northam
- b. Any invitation or offer of tickets not addressed to the Shire of Northam is not captured by this policy and must be disclosed in accordance with the gift and interest provisions in the Act
- c. A list of events and attendees authorised by the local government in advance of the event is at Appendix A.

2. Approval of attendance

- a. The Chief Executive Officer is approved to attend and local, state or national conference in accordance with his/her current contract of employment
- b. In making a decision on attendance at an event, Council will consider:
 - i. who is providing the invitation or ticket to the event
 - ii. the location of the event in relation to the local government (within the district or out of the district)
 - iii. the role of the CEO when attending the event (participant, observer, presenter) and the value of their contribution
 - iv. whether the event is sponsored by the local government
 - v. the benefit of local government representation at the event
 - vi. the number of invitations / tickets received, and
 - vii. the cost to attend the event, including the cost of the ticket (or estimated value of the event per invitation) and any other expenses such as travel and accommodation.
- c. Decisions to attend events in accordance with this policy will be made by simple majority of Council and in accordance with any authorisation provided in this policy.

3. Payments in respect of attendance

- a. Where an invitation or ticket to an event is provided free of charge, the local government may contribute to appropriate expenses for attendance, such as travel and accommodation, for events outside the district if Council determine attendance to be of public value.
- b. any events where a member of the public is required to pay, unless previously approved and listed in Appendix A, Council will determine whether it is in the best interests of the local government for the CEO or another officer to attend on behalf of Council.
- c. If the council determines that a CEO should attend a paid event, the local government will pay the cost of attendance and reasonable expenses, such as travel and accommodation.
- d. Where partners of an authorised local government representative attend an event, any tickets for that person, if paid for by the local government,



must be reimbursed by the representative unless expressly authorised by Council.

APPENDIX A – Events Authorised in Advance (subject to available budgets)

- a. Advocacy lobbying or ministerial briefings
- b. Meetings of clubs or organisations within the Shire of Northam
- c. Any free event held within the Shire of Northam
- d. West Australian-based local government events
- e. Events hosted by clubs or not-for-profit organisations within the Shire of Northam to which the Chief Executive Officer has been officially invited
- f. Shire of Northam hosted events, ceremonies and functions
- g. Local Community art exhibitions
- h. Shire of Northam local cultural events/festivals
- i. Events run by a local, state or federal government
- j. Events run by schools and universities within the Shire of Northam
- k. Major professional bodies associated with local government at a local, state and national level
- l. Opening or launch of an event or facility within the Shire of Northam

APPENDIX B – Specific Event Approvals

Event	Date of Event if known	Approved attendee	Approved local government contribution	Date of Council resolution



Shire of Northam Policy Manual (Section I)
Policy
G 1.4 Code of Conduct for Councillors, Committee Members and
Candidates

GOVERNANCE)

G 1.4 Code of Conduct for Councillors, Committee Members and Candidates

<i>Responsible Department</i>	CEO Office
<i>Resolution Number</i>	C.4200
<i>Resolution Date</i>	21/04/2021
<i>Next Scheduled Review</i>	2023
<i>Related Shire Documents</i>	Nil
<i>Related Legislation</i>	Local Government (Model Code of Conduct) Regulations 2021

OBJECTIVE

SCOPE

Council Members, Committee Members and Candidates.

POLICY

Division 1 – Preliminary provisions

1. Citation

This is the Shire of Northam's Code of Conduct for Council Members, Committee Members and Candidates.

2. Terms used

(1) In this code —

Act means the Local Government Act 1995;

candidate means a candidate for election as a council member;

complaint means a complaint made under clause 11(1);

publish includes to publish on a social media platform.

(2) Other terms used in this code that are also used in the Act have the same meaning as they have in the Act, unless the contrary intention appears.



Division 2 – General principles

3. Overview of Division

This Division sets out general principles to guide the behaviour of council members, committee members and candidates.

4. Personal Integrity

(1) A council member, committee member or candidate should —

- (a) act with reasonable care and diligence; and
- (b) act with honesty and integrity; and
- (c) act lawfully; and
- (d) identify and appropriately manage any conflict of interest. It is the individual responsibility of members and candidates to disclose any conflicts and ensure that they are managed appropriately to comply with the Model Code and serve their community as expected by the local electors.; and
- (e) avoid damage to the reputation of the local government.

(2) A council member or committee member should —

- (a) act in accordance with the trust placed in council members and committee members; and
- (b) participate in decision-making in an honest, fair, impartial and timely manner; and
- (c) actively seek out and engage in training and development opportunities to improve the performance of their role; and
- (d) attend and participate in briefings, workshops and training sessions provided or arranged by the local government in relation to the performance of their role.

5. Relationship with others

(1) A council member, committee member or candidate should —

- (a) treat others with respect, courtesy and fairness; and
- (b) respect and value diversity in the community.



*Shire of Northam Policy Manual (Section I)
Policy
G 1.4 Code of Conduct for Councillors, Committee Members and
Candidates*

- (2) A council member or committee member should maintain and contribute to a harmonious, safe and productive work environment.

6. Accountability

A council member or committee member should —

- (a) base decisions on relevant and factually correct information; and
- (b) make decisions on merit, in the public interest and in accordance with statutory obligations and principles of good governance and procedural fairness; and
- (c) read all agenda papers given to them in relation to council or committee meetings; and
- (d) be open and accountable to, and represent, the community in the district.

Division 3 – Behaviour

7. Overview of Division

This Division sets out —

- (a) requirements relating to the behaviour of council members, committee members and candidates; and
- (b) the mechanism for dealing with alleged breaches of those requirements.

8. Personal integrity

(1) A council member, committee member or candidate —

- (a) must ensure that their use of social media and other forms of communication complies with this code; and
- (b) must only publish material that is factually correct.

(2) A council member or committee member —

- (a) must not be impaired by alcohol or drugs in the performance of their official duties; and
- (b) must comply with all policies, procedures and resolutions of the local government.

9. Relationship with others

A council member, committee member or candidate —



Shire of Northam Policy Manual (Section 1)
Policy
G 1.4 Code of Conduct for Councillors, Committee Members and
Candidates

- (a) must not bully or harass another person in any way; and
- (b) must deal with the media in a positive and appropriate manner and in accordance with any relevant policy of the local government; and
- (c) must not use offensive or derogatory language when referring to another person; and
- (d) must not disparage the character of another council member, committee member or candidate or a local government employee in connection with the performance of their official duties; and
- (e) must not impute dishonest or unethical motives to another council member, committee member or candidate or a local government employee in connection with the performance of their official duties.

10. Council or committee meetings

When attending a council or committee meeting, a council member, committee member or candidate —

- (a) must not act in an abusive or threatening manner towards another person; and
- (b) must not make a statement that the member or candidate knows, or could reasonably be expected to know, is false or misleading; and
- (c) must not repeatedly disrupt the meeting; and
- (d) must comply with any requirements of a local law of the local government relating to the procedures and conduct of council or committee meetings; and
- (e) must comply with any direction given by the person presiding at the meeting; and
- (f) must immediately cease to engage in any conduct that has been ruled out of order by the person presiding at the meeting.

11. Complaint about alleged breach

- (1) A person may make a complaint, in accordance with subclause (2), alleging a breach of a requirement set out in this Division.
- (2) A complaint must be made —



- (a) in writing in the form approved by the local government; and
 - (b) to a person authorised under subclause (3); and
 - (c) within 1 month after the occurrence of the alleged breach.
- (3) The local government must, in writing, authorise 1 or more persons to receive complaints and withdrawals of complaints.

12. Dealing with complaint

- (1) After considering a complaint, the local government must, unless it dismisses the complaint under clause 13 or the complaint is withdrawn under clause 14(1), make a finding as to whether the alleged breach the subject of the complaint has occurred.
- (2) Before making a finding in relation to the complaint, the local government must give the person to whom the complaint relates a reasonable opportunity to be heard.
- (3) A finding that the alleged breach has occurred must be based on evidence from which it may be concluded that it is more likely that the breach occurred than that it did not occur.
- (4) If the local government makes a finding that the alleged breach has occurred, the local government may —
 - (a) take no further action; or
 - (b) prepare and implement a plan to address the behaviour of the person to whom the complaint relates.
- (5) When preparing a plan under subclause (4)(b), the local government must consult with the person to whom the complaint relates.
- (6) A plan under subclause (4)(b) may include a requirement for the person to whom the complaint relates to do 1 or more of the following —
 - (a) engage in mediation;
 - (b) undertake counselling;
 - (c) undertake training;
 - (d) take other action the local government considers appropriate.



- (7) If the local government makes a finding in relation to the complaint, the local government must give the complainant, and the person to whom the complaint relates, written notice of —
- (a) its finding and the reasons for its finding; and
 - (b) if its finding is that the alleged breach has occurred — its decision under subclause (4).

13. Dismissal of complaint

- (1) The local government must dismiss a complaint if it is satisfied that —
- (a) the behaviour to which the complaint relates occurred at a council or committee meeting; and
 - (b) either —
 - (i) the behaviour was dealt with by the person presiding at the meeting; or
 - (ii) the person responsible for the behaviour has taken remedial action in accordance with a local law of the local government that deals with meeting procedures.
- (2) If the local government dismisses a complaint, the local government must give the complainant, and the person to whom the complaint relates, written notice of its decision and the reasons for its decision.

14. Withdrawal of complaint

- (1) A complainant may withdraw their complaint at any time before the local government makes a finding in relation to the complaint.
- (2) The withdrawal of a complaint must be —
- (a) in writing; and
 - (b) given to a person authorised under clause 11(3).

15. Other provisions about complaints

- (1) A complaint about an alleged breach by a candidate cannot be dealt with by the local government unless the candidate has been elected as a council member.



- (2) The procedure for dealing with complaints may be determined by the local government to the extent that it is not provided for in this Division.

Division 4 – Rules of conduct

Notes for this Division:

1. Under section 5.105(1) of the Act a council member commits a minor breach if the council member contravenes a rule of conduct. This extends to the contravention of a rule of conduct that occurred when the council member was a candidate.
2. A minor breach is dealt with by a standards panel under section 5.110 of the Act.

16. Overview of Division

- (1) This Division sets out rules of conduct for council members and candidates.
- (2) A reference in this Division to a council member includes a council member when acting as a committee member.

17. Misuse of local government resources

- (1) In this clause —

electoral purpose means the purpose of persuading electors to vote in a particular way at an election, referendum or other poll held under the Act, the Electoral Act 1907 or the Commonwealth Electoral Act 1918;

resources of a local government includes —

- (a) local government property; and
 - (b) services provided, or paid for, by a local government.
- (2) A council member must not, directly or indirectly, use the resources of a local government for an electoral purpose or other purpose unless authorised under the Act, or by the local government or the CEO, to use the resources for that purpose.

18. Securing personal advantage or disadvantaging others

- (1) A council member must not make improper use of their office —
- (a) to gain, directly or indirectly, an advantage for the council member or any other person; or



(b) to cause detriment to the local government or any other person.

- (2) Subclause (1) does not apply to conduct that contravenes section 5.93 of the Act or The Criminal Code section 83.

19. Prohibition against involvement in administration

- (1) A council member must not undertake a task that contributes to the administration of the local government unless authorised by the local government or the CEO to undertake that task.
- (2) Subclause (1) does not apply to anything that a council member does as part of the deliberations at a council or committee meeting.

20. Relationship with local government employees

- (1) In this clause —

local government employee means a person —

- (a) employed by a local government under section 5.36(1) of the Act; or
- (b) engaged by a local government under a contract for services.

- (2) A council member or candidate must not —

- (a) direct or attempt to direct a local government employee to do or not to do anything in their capacity as a local government employee; or
- (b) attempt to influence, by means of a threat or the promise of a reward, the conduct of a local government employee in their capacity as a local government employee; or
- (c) act in an abusive or threatening manner towards a local government employee.

- (3) Subclause (2)(a) does not apply to anything that a council member does as part of the deliberations at a council or committee meeting.

- (4) If a council member or candidate, in their capacity as a council member or candidate, is attending a council or committee meeting or other organised event (for example, a briefing or workshop), the council member or candidate must not orally, in writing or by any other means —

- (a) make a statement that a local government employee is incompetent or dishonest; or
- (b) use an offensive or objectionable expression when referring to a local government employee.



- (5) Subclause (4)(a) does not apply to conduct that is unlawful under The Criminal Code Chapter XXXV.

21. Disclosure of information

- (1) In this clause —
closed meeting means a council or committee meeting, or a part of a council or committee meeting, that is closed to members of the public under section 5.23(2) of the Act;

confidential document means a document marked by the CEO, or by a person authorised by the CEO, to clearly show that the information in the document is not to be disclosed;

document includes a part of a document;

non-confidential document means a document that is not a confidential document.

- (2) A council member must not disclose information that the council member —
- (a) derived from a confidential document; or
 - (b) acquired at a closed meeting other than information derived from a non-confidential document.
- (3) Subclause (2) does not prevent a council member from disclosing information —
- (a) at a closed meeting; or
 - (b) to the extent specified by the council and subject to such other conditions as the council determines; or
 - (c) that is already in the public domain; or
 - (d) to an officer of the Department; or
 - (e) to the Minister; or
 - (f) to a legal practitioner for the purpose of obtaining legal advice; or
 - (g) if the disclosure is required or permitted by law.

22. Disclosure of interests

- (1) In this clause —



Shire of Northam Policy Manual (Section I)
Policy
G 1.4 Code of Conduct for Councillors, Committee Members and
Candidates

interest —

- (a) means an interest that could, or could reasonably be perceived to, adversely affect the impartiality of the person having the interest; and
 - (b) includes an interest arising from kinship, friendship or membership of an association.
- (2) A council member who has an interest in any matter to be discussed at a council or committee meeting attended by the council member must disclose the nature of the interest —
- (a) in a written notice given to the CEO before the meeting; or
 - (b) at the meeting immediately before the matter is discussed.
- (3) Subclause (2) does not apply to an interest referred to in section 5.60 of the Act.
- (4) Subclause (2) does not apply if a council member fails to disclose an interest because the council member did not know —
- (a) that they had an interest in the matter; or
 - (b) that the matter in which they had an interest would be discussed at the meeting and the council member disclosed the interest as soon as possible after the discussion began.
- (5) If, under subclause (2)(a), a council member discloses an interest in a written notice given to the CEO before a meeting, then —
- (a) before the meeting the CEO must cause the notice to be given to the person who is to preside at the meeting; and
 - (b) at the meeting the person presiding must bring the notice and its contents to the attention of the persons present immediately before any matter to which the disclosure relates is discussed.
- (6) Subclause (7) applies in relation to an interest if —
- (a) under subclause (2)(b) or (4)(b) the interest is disclosed at a meeting; or
 - (b) under subclause (5)(b) notice of the interest is brought to the attention of the persons present at a meeting.
- (7) The nature of the interest must be recorded in the minutes of the meeting.



*Shire of Northam Policy Manual (Section I)
Policy
G 1.4 Code of Conduct for Councillors, Committee Members and
Candidates*

23. Compliance with plan requirement

If a plan under clause 12(4)(b) in relation to a council member includes a requirement referred to in clause 12(6), the council member must comply with the requirement.

24. Further Information

Further advice and information regarding this Code can be obtained from the Chief Executive Officer.



GOVERNANCE

G 1.5 Legal Representation for Council Members and Employees

<i>Responsible Department</i>	Chief Executive Officer
<i>Resolution Number</i>	C.4052
<i>Resolution Date</i>	21/10/2020
<i>Next Scheduled Review</i>	2022
<i>Related Shire Documents</i>	
<i>Related Legislation</i>	Local Government Act 1995 Legal Representation for Council Members and Employees Guideline No. 14, April 2006 – Department of Local Government and Regional Development

OBJECTIVE

To provide a clear framework under which financial assistance will be provided to Council Members and employees for legal services in connection with their roles.

SCOPE

Applies to all Council Members and employees.

POLICY

1. Definitions

Approved lawyer is to be –

- (a) A 'certified practitioner' under the Legal Profession Act 2008;
- (b) from a law firm on the Shire panel of legal service providers, relevant, unless Council considers that this is not appropriate –for example where there is or may be a conflict of interest or insufficient expertise; and
- (c) Approved in writing by Council or the Chief Executive Officer under delegated authority.

Council Member or employee means a current or former Commissioner, elected member, non-elected member of a Council committee or employee of the Shire.



Legal proceedings may be civil, criminal or investigative.

Legal representation is the provision of legal services, to or on behalf of an Council Member or employee, by an approved lawyer that are in respect of –

- (a) a matter or matters arising from the performance of the functions of an Council Member or employee; and
- (b) legal proceedings involving the Council Member or employee that have been, or may be commenced.

Legal representation costs are the costs, including fees and disbursements, properly incurred in providing legal representation.

Legal services includes advice, representation or documentation that is provided by an approved lawyer.

Payment by the Shire of legal representation costs may be either by –

- (a) a direct payment to the approved lawyer (or the relevant firm); or
- (b) a reimbursement to the council member or employee.

2. Payment Criteria

The Shire of Northam may approve the legal representation costs of a Council Member or employee if the following criteria is satisfied:

- (a) The legal representation costs must relate to a matter that arises from the performance, by the Council Member or employee, of his or her functions;
- (b) The legal representation cost must be in respect of legal proceedings that have been, or may be commenced;
- (c) In performing his or her functions, to which the legal representation relates, the Council Member or employee must have acted in good faith, and must not have acted unlawfully or in a way that constitutes improper conduct; and
- (d) The legal representation costs do not relate to a matter that is of a personal or private nature.

3. Examples of Legal Representation Costs that May be Approved

- 3.1 If the criteria in clause 2 of this policy are satisfied, the Shire may approve the payment of legal representation costs –



- (a) where proceedings are brought against a Council Member or employee in connection with his or her functions – for example, an action for defamation or negligence arising out of a decision made or action taken by the Council Member or employee; or
- (b) to enable proceedings to be commenced and/or maintained by an Council Member or employee to permit him or her to carry out his or her functions - for example where a Council Member or employee seeks to take action to obtain a restraining order against a person using threatening behaviour to the Council Member or employee; or
- (c) where exceptional circumstances are involved – for example, where a person or organisation is lessening the confidence of the community in the local government by publicly making adverse personal comments about Council Members or employees.

3.2 The Shire will not approve, unless under exceptional circumstances, the payment of legal representation costs for a defamation action, or a negligence action, instituted by a Council Member or employee.

4. Application For Payment

- 4.1 A Council Member or employee who seeks assistance under this policy is to make an application(s), in writing to the Chief Executive Officer.
- 4.2 The written application for payment of legal representation costs is to give details of –
 - (a) The matter for which legal representation is sought;
 - (b) How that matter relates to the functions of the Council Member or employee making the application;
 - (c) The lawyer (or law firm) who is to be asked to provide the legal representation;
 - (d) The nature of legal representation to be sought (such as advice, representation in court, preparation of a document);
 - (e) An estimated cost of the legal representation; and
 - (f) Why it is in the interests of the Shire for payment to be made.
- 4.3 The application is to contain a declaration by the applicant that he or she has acted in good faith, and has not acted unlawfully or in a way that constitutes improper conduct in relation to the matter to which the application relates.



Shire of Northam Policy Manual (Section I)
Policy
G 1.5 Legal Representation for Council Members and Employees

- 4.4 As far as possible the application is to be made before commencement of the legal representation to which the application relates.
- 4.5 The application is to be accompanied by a signed written statement by the applicant that he or she –
- (a) has read, and understands, the terms of this Policy;
 - (b) acknowledges that any approval of legal representation costs is conditional on the repayment provisions of Clause 8 and any other conditions to which the approval is subject; and
 - (c) undertakes to repay to the Shire any legal representation costs in accordance with the provisions of Clause 8.
- 4.6 In relation to clause 4.5(c), when a person is to be in receipt of such monies the person should sign a document which requires repayment of that money to the local government as may be required by the Shire and the terms of the Policy.
- 4.7 An application is also to be accompanied by a report prepared by the Chief Executive Officer or where the Chief Executive Officer is the applicant by an appropriate employee.

5. Legal Representation Costs – Limit

- 5.1 Council in approving an application in accordance with this policy shall set a limit on the costs to be paid based on the estimated costs in the application.
- 5.2 A Council Member or employee may make a further application to Council in respect of the same matter.

6. Council's Powers

- 6.1 Council may –
- (a) refuse;
 - (b) grant; or
 - (c) grant subject to conditions,
- an application for payment of legal representation costs.
- 6.2 Conditions under clause 6.1 may include, but are not restricted to, a financial limit and/or a requirement to enter into a formal agreement,



including a security agreement, relating to the payment, and repayment, of legal representation costs.

- 6.3 In assessing an application, Council may have regard to any insurance benefits that may be available to the applicant under the Shire's Council Members or employees insurance policy or its equivalent.
- 6.4 Council may at any time revoke or vary an approval or any conditions of approval, for the payment of legal representation costs.
- 6.5 Council may, subject to clause 6.6, determine that a Council Member or employee whose application for legal representation costs has been approved has, in respect of the matter for which legal representation costs were approved –
 - (a) not acted in good faith, or has acted unlawfully or in a way that constitutes improper conduct; or
 - (b) given false or misleading information in respect of the application.
- 6.6 A determination under clause 6.5 may be made by Council only on the basis of, and consistent with, the findings of a court, tribunal or inquiry.
- 6.7 Where Council makes a determination under clause 6.5, the legal representation costs paid by the Shire are to be repaid by the Council Member or employee in accordance with section 8.

7. Delegation to Chief Executive Officer

- 7.1 In cases where a delay in the approval of an application will be detrimental to the legal rights of the applicant the Chief Executive Officer may exercise, on behalf of Council, any of the powers of Council under clause 6.1 and 6.2, to a maximum of \$10,000 in respect of each application.
- 7.2 An application approved by the Chief Executive Officer under clause 6.1, is to be submitted to the next ordinary meeting of Council. Council may exercise any of its powers under this policy, including its powers under clause 6.4.

8. Repayment of Legal Representation Costs

- 8.1 A Council Member or employee whose legal representation costs have been paid by the Shire is to repay the Shire –
 - (a) all or part of those costs – in accordance with a determination by Council under clause 6.7;
 - (b) as much of those costs as are available to be paid by way of set-off – where the Council Member or employee receives monies paid for



Shire of Northam Policy Manual (Section I)
Policy
G 1.5 Legal Representation for Council Members and Employees

costs, damages, or settlement, in respect of the matter for which the Shire paid the legal representation costs.

- 8.2 The Shire may take action in a court of competent jurisdiction to recover any monies due to it under this policy.



Shire of Northam Policy Manual (Section I)
Policy

G 1.6 Approval of annual & long service leave for the CEO and
appointment of an Acting CEO

GOVERNANCE

G 1.6 Approval of annual & long service leave for the CEO and appointment of an Acting CEO

<i>Responsible Department</i>	Chief Executive Officer
<i>Resolution Number</i>	TBC
<i>Resolution Date</i>	TBC
<i>Next Scheduled Review</i>	2024
<i>Related Shire Documents</i>	
<i>Related Legislation</i>	S5.36, 5.39C, 5.40 Local Government Act 1995

OBJECTIVE

To establish policy, in accordance with Section 5.39C of the Local Government Act 1995 ('the Act'), that details the Shire of Northam's processes for appointing an Acting or Temporary Chief Executive Officer (CEO) for periods of less than 12 months of planned or unplanned leave or an interim vacancy in the substantive office.

SCOPE

This policy applies to the statutory position of Chief Executive Officer (CEO) of the Shire of Northam.

POLICY

1. Definitions:

- (1) **Acting CEO** means a person employed or appointed to fulfil the statutory position of CEO during a period where the substantive CEO remains employed, but is on planned or unplanned leave.
- (2) **Temporary CEO** means a person employed or appointed to fulfil the statutory position of CEO for the period of time between the end of the substantive CEO's employment and the appointment and commencement of a newly appointed substantive CEO.

2. Approval of Annual & Long Service Leave

The Shire of Northam Council approves the taking of leave by the Chief Executive Officer and the appointment of an Acting Chief Executive Officer for a period not exceeding six (6) weeks, in accordance with the following parameters:

CEO-POLICY-05 G 1.6 Approval of annual and long service leave for the CEO and
appointment of an Acting CEO_V2

Page 1 of 4



*Shire of Northam Policy Manual (Section I)
Policy*

*G 1.6 Approval of annual & long service leave for the CEO and
appointment of an Acting CEO*

1. The Shire President, or in his/her absence the Deputy Shire President, authorise all annual and long service leave to be taken by the Chief Executive Officer, so long as the period of leave does not exceed 6 weeks.

3. Acting and Temporary CEO Requirements and Qualification

- (1) When the CEO is on planned or unplanned leave, or the CEO's employment with the Local Government has ended, an Acting or Temporary CEO is to be appointed in accordance with this Policy to fulfil the functions of CEO as detailed in Section 5.41 of the *Local Government Act 1995*, and other duties as set out in the Act and associated Regulations.
- (2) Through this policy and in accordance with section 5.36(2)(a) of the Act, the Council determines that employees appointed to the substantive position(s) of Executive Manager/s are considered suitably qualified to perform the role of Acting or Temporary CEO.
- (3) A person appointed to act in the position of Executive Manager/s is not included in the determination set out in Clause 3 (2).

4. Appoint Acting CEO – Planned and unplanned leave for periods up to 6 weeks

- (1) The CEO is authorised to appoint the Executive Manager/s in writing as Acting CEO, where the CEO is on planned or unplanned leave for periods not exceeding 6 weeks, subject to the CEO's consideration of the Executive Manager/s performance, availability, operational requirements and where appropriate, the equitable access to the professional development opportunity.
- (2) The CEO must appoint an Acting CEO for any leave periods greater than 5 days and less than 6 weeks.
- (3) The CEO is to immediately advise all Council Members when and for what period of time the Executive Manager/s is appointed as Acting CEO.
- (5) Council may, by resolution, extend an Acting CEO period under subclause (4) beyond 6 weeks if the substantive CEO remains unavailable or unable to perform their functions and duties.

5. Appoint Acting CEO for extended leave periods greater than 6 weeks but less than 12 months.

- (1) This clause applies to the following periods of extended leave:
 - a. Substantive CEO's Extended Planned Leave which may include accumulated annual leave, long service leave or personal leave; and



*Shire of Northam Policy Manual (Section I)
Policy*

*G 1.6 Approval of annual & long service leave for the CEO and
appointment of an Acting CEO*

- b. Substantive CEO's Extended Unplanned Leave which may include any disruption to the substantive CEO's ability to continuously perform their functions and duties.
- (2) The Council will, by resolution, appoint an Acting CEO for periods greater than 6 weeks but less than 12 months, as follows:
- a. Appoint one employee, or multiple employees for separate defined periods, as Acting CEO to ensure the CEO position is filled continuously for the period of extended leave; or
 - b. Conduct an external recruitment process in accordance with clause 6(1)(c).
- (3) The President (or in their absence the Deputy President) will liaise with the CEO, or in their unplanned absence the People and Culture Coordinator to coordinate Council reports and resolutions necessary to facilitate an Acting CEO appointment.
- (4) Subject to Council's resolution, the President (or in their absence the Deputy President) will execute in writing the Acting CEO appointment with administrative assistance from the People and Culture Coordinator.

6. Appoint Temporary CEO – Substantive Vacancy

- (1) In the event that the substantive CEO's employment with the Shire of Northam is ending, the Council when determining to appoint a Temporary CEO may either:
- a. by resolution, appoint an Executive Manager/s as the Temporary CEO for the period of time until the substantive CEO has been recruited and commences their employment with the Local Government; or
 - b. by resolution, appoint **an Executive Manager/s** as the interim Temporary CEO for the period of time until an external recruitment process for a Temporary CEO can be completed; or
 - c. following an external recruitment process in accordance with the principles of merit and equity prescribed in section 5.40 of the Act, appoint a Temporary CEO for the period of time until the substantive CEO has been recruited and commences employment with the Local Government.
- (2) The President (or in their absence the Deputy President) will liaise with the People and Culture Coordinator to coordinate Council reports and resolutions necessary to facilitate a Temporary CEO appointment.
- (3) The President (or in their absence the Deputy President) is authorised to execute in writing the appointment of a Temporary CEO in accordance with



*Shire of Northam Policy Manual (Section I)
Policy
G 1.6 Approval of annual & long service leave for the CEO and
appointment of an Acting CEO*

Councils resolution/s, with administrative assistance from the People and Culture Coordinator.

7. Remuneration and conditions of Acting or Temporary CEO

- (1) Unless Council otherwise resolves, an employee appointed as Acting CEO shall be remunerated at no less than 85% of the cash component only of the substantive CEO's total reward package.
- (2) Council will determine by resolution, the remuneration and benefits to be offered to a Temporary CEO when entering into a contract in accordance with the requirements of Sections 5.39(1) and (2)(a) of the Act.
- (3) Subject to relevant advice, the Council retains the right to terminate or change, by resolution, any Acting or Temporary CEO appointment.



GOVERNANCE

G 1.7 Senior Employees

<i>Responsible Department</i>	Chief Executive Officer
<i>Resolution Number</i>	C.4052
<i>Resolution Date</i>	21/10/2020
<i>Next Scheduled Review</i>	2022
<i>Related Shire Documents</i>	
<i>Related Legislation</i>	S5.37 Local Government Act 1995

OBJECTIVE

To comply with the provisions of the *Local Government Act 1995* towards designated Senior Officers.

SCOPE

Applies to the Chief Executive Officer.

POLICY

In accordance with Section 5.37 of the *Local Government Act 1995*, the Shire of Northam has no designated "Senior Employees", other than the Chief Executive Officer.



GOVERNANCE

G 1.8 Risk Management

<i>Responsible Department</i>	Chief Executive Officer
<i>Resolution Number</i>	C.4052
<i>Resolution Date</i>	21/10/2020
<i>Next Scheduled Review</i>	2022
<i>Related Shire Documents</i>	
<i>Related Legislation</i>	AS/NZS ISO 31000:2009

OBJECTIVE

As a local government, the Shire of Northam has exposure to a range of risks that, if unmanaged, may have an adverse impact on the achievement of organisational objectives.

The Shire will implement an enterprise-wide risk management framework and systems to identify and manage potential risks to minimise adverse outcomes. The policy intent is to build a risk-mature environment where Council, management and employees take responsibility for risk management through systemic practices to:

- Safeguard the Shire people, assets, property, environment, reputation, finances and information;
- Promote an environment where risk management principles and practices are the tools to the achievement of organisational goals; and
- Provide the resources required to minimise adverse reaction to risks.

SCOPE

Organisational wide.

POLICY

The Shire of Northam is committed to managing risk in accordance with the principles, framework and guidelines detailed in *AS/NZS ISO 31000:2009* and will:

- Implement an Enterprise Risk Management Framework and Plan;
- Identify strategic, operational and project risks using systematic tools and based on the level of risk ensure effective Risk Treatment Plans are in place to minimise such risks;



- Ensure any item with a risk ranking of greater than 10, categorised as either a high or extreme risk and is apparent to be ongoing, be listed on the Shire's Risk Register;
- Align risk management systems and processes with current strategic and operational planning processes;
- Implement a range of risk management key performance indicators to monitor responsibility and accountability

Report, Monitor and Review

In accordance with Local Government (Audit) Regulations 1996, regular reporting of systems and procedures in relation to risk management will be submitted to the Shire's Audit and Risk Management Committee, and that committee will have the Shire's Risk Register as a standing agenda item.

Performance of Shire of Northam risk management will be measured against:

- % of High or Extreme Risks without mitigation strategies in place
 - Reported quarterly to Audit and Risk Management Committee
- % of risk mitigation strategies overdue
 - Reported quarterly to Audit and Risk Management Committee

Risk Criteria and Evaluation

Risk criteria also needs to be defined to evaluate the significance of risk. Factors to be considered include the following:

- The nature and types of causes and consequences that can occur and how they will be measured;
- How likelihood will be defined;
- The timeframe (s) of the likelihood and/or consequence (s);
- How the level of risk is to be determined;
- The views of stakeholders; and
- The level at which risk becomes acceptable or tolerable

Risk evaluation always involves the assessment of the likelihood (chance of something happening) and consequence (outcome of an event affecting objectives) of an event.



Risk Assessment Tool

Measures of Consequence

Level Description	Financial Impacts	Health & Safety	Reputation	Service Interruption	Compliance	Property	Environment
Insignificant (1)	<\$10,000	Medical type injuries	Unsubstantiated, low impact, low profile, or no news item	No material service interruption	No noticeable regulatory or statutory impact	Inconsequential damage.	Contained, reversible impact managed by on site response
Minor (2)	\$10,001 - \$25,000	Lost Time Injury <30 days	Low impact, low news item	Short term temporary interruption – backlog cleared < 1 day	Some temporary non compliances	Localised damage rectified by routine internal procedures	Contained, reversible impact managed by internal response
Medium (3)	\$25,001 - \$250,000	Lost time Injury >30 Days	Substantiated, public embarrassment, moderate impact, moderate news profile	Medium term temporary interruption – backlog cleared by additional resources < 1 week	Short term non-compliance but with significant regulatory requirements imposed	Localised damage requiring external resources to rectify	Contained, reversible impact managed by external agencies
High (4)	\$250,001 - \$650,000	Long term disability / multiple injuries	Substantiated, public embarrassment, high impact news profile, third party actions	Prolonged interruption of services – additional resources; performance affected < 1 month	Non-compliance results in termination of services or imposed penalties	Significant damage requiring internal & external resources to rectify	Uncontained, reversible impact managed by a coordinated response from external agencies
Extreme (5)	> \$650,000	Death or permanent disablement	Substantiated, public embarrassment, very high multiple impacts, high, widespread multiple news profile, third party actions	Indeterminate prolonged interruption of services – non-performance > 1 month	Non-compliance results in litigation, criminal charges or significant damages or penalties	Extensive damage requiring prolonged period of restitution. Complete loss of plant, equipment & building	Uncontained, irreversible impact



As defined by the Australian Standard, consequence is the outcome of an event affecting corporate objectives. The above identifies outcomes in seven main categories: health and safety; financial impact; service interruption; compliance; reputation; property; and environment. A level of 1 - 5 is applied based on the severity of the outcome, ranging from insignificant to catastrophic. Combined with measures of likelihood, measures of consequence form the evaluation of risks in the risk matrix (see below).

Measures of Likelihood

Description	Examples	Frequency
Almost Certain (5)	The event is expected to occur	More than once per year
Likely (4)	The event will probably occur	At least once per year
Possible (3)	The event could occur	At least once in five years
Unlikely (2)	The event could occur but probably won't	At least once in ten years
Rare (1)	The event is not expected to occur	Less than once in 20 years

Measures of likelihood form part of the risk matrix to determine the 'risk rank' and the 'level of risk'.

A level of 1 – 5 is applied based on the likelihood of an event occurring, ranging from rare to almost certain. The likelihood can be determined objectively or subjectively, qualitatively or quantitatively, and described using general terms or mathematically such as probability or a frequency over a given time period.

Risk Appetite

Risk appetite is the amount of risk exposure, or potential adverse impact from an event, that the Shire of Northam is willing to accept in pursuit of its objectives. Once the risk appetite threshold has been breached, risk management controls and actions are required to bring the exposure level back within the accepted range.

The Shire of Northam has a level of risk appetite that it tolerates, consisting of low, medium, high and extreme risks, as detailed in the below table:

Risk rating	Minimum treatment required	Description
Extreme	Reject and avoid or mitigate	Immediate action required in consultation with Chief Executive Officer of Executive Manager to either avoid the risk entirely or to reduce the risk to a low, medium or high rating. Council decision, or at a minimum advice, required



Shire of Northam Planning Policy Manual (Section I)
Policy
G 1.8 Risk Management

High risk	Accept and mitigate	These risks need to be mitigated with actions as required and managers need to be assigned these risks
Medium risk	Accept	Manage by specific monitoring or response procedures
Low risk	Accept	Manage by routine procedures



Risk Matrix

Consequence / Likelihood	Insignificant (1)	Minor (2)	Medium (3)	Major (4)	Extreme (5)
Almost Certain (5)	Moderate (5)	High (10)	High (15)	Extreme (20)	Extreme (25)
Likely (4)	Low (4)	Moderate (8)	High (12)	High (16)	Extreme (20)
Possible (3)	Low (3)	Moderate (6)	Moderate (9)	High (12)	High (15)
Unlikely (2)	Low (2)	Low (4)	Moderate (6)	Moderate (8)	High (10)
Rare (1)	Low (1)	Low (2)	Low (3)	Low (4)	Moderate (5)

The risk matrix will determine a risk ranking and level of risk based on the measurement of the likelihood and consequence of a particular event. Any event with a risk ranking of 'high' or 'extreme' will be recorded in the Shire's Risk Register and reported to the Audit and Risk Management Committee on a periodic basis. These events require regular monitoring and risk treatment actions which may involve the following:

- Avoiding the risk by deciding not to start or continue with the activity that gives rise to the risk;
- Accepting risk in order to pursue an opportunity;
- Removing the risk source;
- Changing the likelihood;
- Changing the consequences;
- Sharing the risk with another party or parties (including contracts and risk financing); and
- Retaining the risk by informed decision

Risk treatments that deal with negative consequences are sometimes referred to as risk mitigation, risk elimination, risk prevention and risk reduction. Risk treatments will be particularly important where existing controls are deemed to be inadequate.

Sources of Risk Identification

- Identified organisational risks
- Various plans and strategies (refer to the Corporate Business Plan for a list of Council-endorsed plans)
- Major projects
- Council agenda items



Shire of Northam Policy Manual (Section I)
Policy
G 1.9 Council and Committee Member and Staff Interactions and
Requests for Information

GOVERNANCE

G 1.9 Council and Committee Member and Staff Interactions and Requests for Information

<i>Responsible Department</i>	CEO Office
<i>Resolution Number</i>	TBC
<i>Resolution Date</i>	TBC
<i>Next Scheduled Review</i>	2024/25
<i>Related Shire Documents</i>	Policy G 1.4 Code of Conduct for Councillors, Committee Members & Candidates Corporate Business Plan Strategic Community Plan
<i>Related Legislation</i>	<i>Local Government Act 1995, Part 5, Division 7</i> <i>and</i> <i>Freedom of Information Act 1992.</i>

OBJECTIVE

To provide guidance to Council Members or members of a committee of the Shire of Northam in relation to the process for seeking information from records and staff.

SCOPE

Elected Members have access to certain documents over and above the rights of the general public which are provided for in Section 5.94 of the *Local Government Act 1995*.

Specific additional rights to access of information by Council Members or members of a committee are provided in Section 5.92 of the *Local Government Act 1995* and granted in order to enable a Council Member and/or member of a committee to discharge adequately the functions of their elected office.

The *Local Government Act 1995* stipulates that Council Member or members of a committee may only seek such information from Shire records and files in the pursuit of Shire business. Council Members/members of a committee are not to use information for their own or another person's purpose, benefit or detriment, unconnected with Shire activities.

The policy also provides guidelines on meeting with Council staff.



Shire of Northam Policy Manual (Section I)
Policy
G 1.9 Council and Committee Member and Staff Interactions and
Requests for Information

Definitions

Council Member: means a serving elected member of Council of the Shire of Northam.

Committee Member: means a member of the public appointed by the local government to an endorsed committee of Council

Local Government: means the local government known as the Shire of Northam

Staff: means an employee of the Shire of Northam.

POLICY

Policy Statement

The Chief Executive Officer will ensure that Council Members/Committee Members are provided with access to documents, information and staff, which in the Chief Executive Officer's view are required to enable Council Members/Committee Members to fulfil their functions and/or duties.

Council Members/Committee Members must have the approval of the Chief Executive Officer, or relevant Executive Manager, to meet with staff in relation to Council business.

In the event a Council Member/Committee Member forms a view that they require access to additional documents, information or staff not already specifically provided, the following guidelines are to be adhered to;

- Council Members/Committee Members wishing to obtain information on a Council matter or wishing to arrange a meeting with Shire staff, relating to the business of the Shire, must seek the approval of the Chief Executive Officer.
- Where research may be required to satisfy the Council Member's enquiry, it is preferable that the Council Member/Committee Members give appropriate advance notice of their requirements. Council Members/Committee Members with such a request should put their request in writing and forward it to the Chief Executive Officer or the appropriate Executive Manager.
- The Chief Executive Officer or Executive Manager is to ascertain from the Council Members/Committee Members seeking access to such information the precise nature of the request, the information being sought, and the reason why the information is requested. If the request establishes motivation outside the general guidelines of assisting the Council Members/Committee Members in the proper discharge of their responsibilities, the Chief Executive Officer may refuse such a request, in accordance with division 7 of the *Local Government Act 1995* and part 7 of the *Local government (Administration) Regulations 1996*.
- If the request for information complies with the intent of this policy and the prevailing legislation, however it places an unreasonable demand on staff time and resources so as to render the research reasonably disruptive to the administration, the Chief Executive Officer may refuse to comply with the request.



Shire of Northam Policy Manual (Section I)
Policy
G 1.9 Council and Committee Member and Staff Interactions and
Requests for Information

- Following any such refusal by the Chief Executive Officer to provide information, if the Council Member/Committee Members still wishes to pursue access to the information, the Council Member/Committee Members is entitled to:
 - Lodge an application under the *Freedom of Information Act 1992*: and/or
 - Present a Notice of Motion to an ordinary meeting of Council, requesting that Council consider directing the Chief Executive Officer to provide the specifically requested information. Council will then make a determination as to whether to approve access to the specifically identified information based on:
 - An explanation provided by the Chief Executive Officer for not providing the requested information, and;
 - The appropriate provisions of the *Local Government Act 1995* and *Local Government (Administration) Regulations 1996*.

Financial/Budget Implications

The examination of any such information requested is to be at the Shire Administration Centre, located at 395 Fitzgerald Street, Northam during reasonable times, such as normal office hours, and is to be free of charge, unless obtained under provisions of the *Freedom of Information Act 1992*.

The original form/source of the information cannot be removed for examination, however photocopies may be taken subject to the payment of appropriate fees and charges as set by Council.

Conformity with Strategic Community / Corporate Business Plan

Performance Area: Performance.

Objective 13.1: Provide strong, open and accountable leadership and be more visible and relevant for community members.



GOVERNANCE

G 1.10 Communications and Social Media Policy

<i>Responsible Department</i>	CEO Office
<i>Resolution Number</i>	TBC
<i>Resolution Date</i>	TBC
<i>Next Scheduled Review</i>	2024/25
<i>Related Shire Documents</i>	Shire of Northam Standing Orders Local Law.
<i>Related Legislation</i>	State Records Act 2000 - SRC Standard 8 – Managing Digital Information.

OBJECTIVE

This policy establishes protocols for the Shire of Northam’s official communications with our community to ensure the Shire of Northam is professionally and accurately represented and to maximise a positive public perception of the Shire of Northam.

SCOPE

This policy applies to:

1. Communications initiated or responded to by Shire of Northam staff with our community; and
2. Council Members when making comment in either their Shire of Northam role or in a personal capacity.

POLICY

1. Official Communications

The purposes of the Shire of Northam’s official communications include:

- Sharing information required by law to be publicly available.
- Sharing information that is of interest and benefit to the community.
- Promoting Shire of Northam events and services.
- Promoting public notices and community consultation / engagement opportunities.
- Answering questions and responding to requests for information relevant to the role of the Shire of Northam



- Receiving and responding to community feedback, ideas, comments, compliments and complaints

The Shire of Northam's official communications will be consistent with relevant legislation, policies, standards and the positions adopted by Council. Our communications will always be respectful and professional.

The Shire of Northam will use a combination of different communication modes to suit the type of information to be communicated and the requirements of the community or specific audience, including:

- Website;
 - Advertising and promotional materials;
 - Media releases prepared for the Shire President and/or Chief Executive Officer, to promote specific Shire of Northam positions;
 - Social media; and
- Community newsletters, letter drops and other modes of communication undertaken by the Shire's administration at the discretion of the Chief Executive Officer.

2. Speaking on behalf of the Shire of Northam

The Shire President is the official spokesperson for the Shire of Northam and may represent the Shire in official communications, including: speeches, comment, print, electronic and social media. [s.2.8(1)(d) of the Local Government Act 1995]

Where the Shire President is unavailable, the Deputy Shire President may act as the spokesperson. [s.2.9 and s.5.34 of the Local Government Act 1995]

The Chief Executive Officer may speak on behalf of the Shire of Northam, where authorised to do so by the Shire President. [s.5.41(f) of the Local Government Act 1995]

The provisions of the *Local Government Act 1995* essentially direct that only the Shire President, or the Chief Executive Officer if authorised, may speak on behalf of the local government. It is respectful and courteous to the office of the Shire President to refrain from commenting publicly, particularly on recent decisions or contemporary issues, until such time as the Shire President has had opportunity to speak on behalf of the Shire of Northam. Council Members commenting publicly are able to do so in accordance with Section 7 of this policy and once the Shire President has had the opportunity to speak on behalf of the Shire (if applicable). Reference should be made to reports within Council agenda/minutes to ascertain whether an official media release will be issued for a particular matter prior to commenting publicly.

Communications by Council Members and employees, whether undertaken in an authorised official capacity or as a personal communication, must not:

- bring the Shire of Northam into disrepute;
- compromise the person's effectiveness in their role with the Shire;



- imply the Shire's endorsement of personal views;
- imply the Council Member or employee is speaking on behalf of the Shire, unless authorised to do so; or
- disclose, without authorisation, confidential information.

Social media accounts or unsecured website forums must not be used to transact meetings which relate to the official business of the Shire of Northam.

Council Member communications must comply with the Code of Conduct and the *Local Government (Rules of Conduct) Regulations 2007*.

3. Responding to Media Enquiries

All enquiries from the media for an official Shire of Northam comment, whether made to an individual Council Member or Employee, must be directed to the Chief Executive Officer or a person authorised by the Chief Executive Officer.

Information will be coordinated to support the Shire President or Chief Executive Officer (where authorised) to make an official response on behalf of the Shire of Northam.

Council Members may make comments to the media in a personal capacity – refer to clause 7.1 below.

4. Website

The Shire of Northam will maintain an official website, as our community's on-line resource to access to the Shire's official communications.

5. Social Media

The Shire of Northam uses social media to facilitate interactive information sharing and to provide responsive feedback to our community. Social media will not, however, be used by the Shire to communicate or respond to matters that are complex or relate to a person's or entity's private affairs.

The Shire of Northam maintains the following social media accounts:

- Shire of Northam Instagram: www.instagram.com/shireofnortham
- Shire of Northam Facebook: www.facebook.com/shireofnortham/
- Visit Northam Facebook: www.facebook.com/visitnortham
- Visit Northam Instagram: www.instagram.com/visitnortham
- Libraries Facebook: www.facebook.com/northamlibrary
- Rec Centre Facebook: www.facebook.com/northamrecreationcentre
- Pools Facebook:
www.facebook.com/search/top/?q=shire%20of%20northam%20aquatics
- Shire YouTube:
https://www.youtube.com/channel/UC39z1LW_yJoHgX27vOnKOow



- Bilya Koort Boodja – Centre for Nyoongar Culture and Environmental Knowledge: www.facebook.com/bkbcentre
- BKB Instagram: www.instagram.com/bilyakoortboodja
- Chief Executive Officer - Twitter

In addition to any other social media accounts approved by the Chief Executive Officer.

The Shire of Northam may also post and contribute to social media hosted by others, so as to ensure that the Shire's strategic objectives are appropriately represented and promoted.

The Shire actively seeks ideas, questions and feedback from our community, however we expect participants to behave in a respectful manner. The Shire of Northam will moderate its social media accounts to address and where necessary delete content deemed to be:

- Offensive, abusive, defamatory, objectionable, inaccurate, false or misleading;
- Promotional, soliciting or commercial in nature;
- Unlawful or incites others to break the law;
- Information which may compromise individual or community safety or security;
- Repetitive material copied and pasted or duplicated;
- Content that promotes or opposes any person campaigning for election to Council, appointment to official office, or any ballot;
- Content that violates intellectual property rights or the legal ownership of interests or another party; and
- Any other inappropriate content or comments at the discretion of the Shire

Where a third party contributor to a Shire of Northam's social media account is identified as posting content which is deleted in accordance with the above, the Shire may at its complete discretion block that contributor for a specific period of time or permanently.

5.1 Shire President Social Media Official Accounts

The Shire of Northam supports the Shire President in using official social media account/s to assist the Shire President in fulfilling their role under section 2.8 of the *Local Government Act 1995*, to speak on behalf of the local government. The content will be administered and moderated in accordance with this policy.

These official Shire of Northam accounts must not be used by the Shire President for personal communications.

5.2 Use of Social Media in Emergency Management and Response

The Shire of Northam will use the following channels to communicate and advise our community regarding Emergency Management:



- Shire website;
- Social media;
- Media releases or media statements;
- Community newsletter including email newsletters;
- SMS messaging; and
- Letter drops and other modes of communications at the discretion of the CEO.

6. Record Keeping and Freedom of Information

Official communications undertaken on behalf of the Shire of Northam, including on the Shire's social media accounts and third party social media accounts, must be created and retained as local government records in accordance with the Shire's Record Keeping Plan and the *State Records Act 2000*. These records are also subject to the *Freedom of Information Act 1992*.

Council Member communications that relate to their role as a Council Member are subject to the requirements of the Shire's Record Keeping Plan and the *State Records Act 2000*. Council Members are responsible for transferring these records to the Shire's administration. Council Member records are also subject to the *Freedom of Information Act 1992*.

7. Personal Communications by Council Members

Personal communications and statements made privately; in conversation, written, recorded emailed, texted or posted in personal social media, have the potential to be made public, whether intended or not.

On the basis that personal or private communications may be shared or become public at some point in the future, Council Members should ensure that their personal or private communications do not breach the requirements of this policy, the Code of Conduct and the *Local Government (Rules of Conduct) Regulations 2007*.

8. Elected Member Statements on Shire Matters

A Council Member may choose to make a personal statement publicly on a matter related to the business of the Shire of Northam.

Any public statement made by a Council Member, whether made in a personal capacity or in their local government representative capacity, must:

1. Clearly state that the comment or content is a personal view only, which does not necessarily represent the views of Shire of Northam.
2. Be made with reasonable care and diligence;
3. Be lawful, including avoiding contravention of; copyright, defamation, discrimination or harassment laws;
4. Be factually correct;



Shire of Northam Policy Manual (Section I)
Policy
G 1.10 Communications and Social Media Policy

5. Avoid damage to the reputation of the local government;
6. Not reflect adversely on a decision of Council;
7. Not reflect adversely on the character or actions of another Council Member or employee;
8. Maintain a respectful and positive tone and not use offensive or objectionable expressions in reference to any Council Member, employee or community member.

A Council Member who is approached by the media for a personal statement may request the assistance of the CEO.

Comments which become public and which breach this policy, the Code of Conduct or the *Local Government (Rules of Conduct) Regulations 2007*, may constitute a minor breach of the *Local Government Act 1995* and may be referred for investigation.



GOVERNANCE

G 1.11 Corporate Uniform – Council Members

<i>Responsible Department</i>	Chief Executive Officer
<i>Resolution Number</i>	C.4052
<i>Resolution Date</i>	21/10/2020
<i>Next Scheduled Review</i>	2022
<i>Related Shire Documents</i>	
<i>Related Legislation</i>	

OBJECTIVE

To encourage and provide assistance to Council Members to wear the corporate uniform.

SCOPE

Applies to all Council Members.

POLICY

The Shire will provide an allowance for Councillors, to the value of \$200 annually (not accumulative) for the purchase of corporate apparel.



Shire of Northam Policy Manual (Section I)
Policy
G 1.16 Acceptable Use of the Shire's Computing & Communication
Resource – Council Members

GOVERNANCE

G 1.16 Acceptable Use of Information Communication Technology (ICT) Resources – Council Members

<i>Responsible Department</i>	Chief Executive Officer
<i>Resolution Number</i>	C.4052
<i>Resolution Date</i>	21/10/2020
<i>Next Scheduled Review</i>	2022
<i>Related Shire Documents</i>	
<i>Related Legislation</i>	

OBJECTIVE

The purpose of this policy is to explain the acceptable use of the Shire's ICT resources and to inform about the consequences of misuse.

SCOPE

This policy applies to all Shire of Northam Council Members that have access to or use of Shire of Northam ICT resources. These persons are expected to comply with this policy.

POLICY

Introduction

All network equipment, email and internet accounts maintained in the Shire of Northam's computing systems are the sole property of the Shire of Northam. The Shire records all internet usage and has the right to monitor the email account or internet browser of any user for legitimate business reasons including compliance with this policy, compliance with any applicable laws and where there is reasonable suspicion of activities that may not conform to this policy.

General Obligations

This policy sets out the minimum acceptable behaviour for the use of the Shire's computing and communication facilities. There is a reasonable expectation that the parties included in the scope of this policy will act professionally and use these resources responsibly according to this policy.



*Shire of Northam Policy Manual (Section I)
Policy
G 1.16 Acceptable Use of the Shire's Computing & Communication
Resource – Council Members*

Reasonable Personal Use

Council Members are permitted personal use of the Shire of Northam provided information technology equipment. This personal use shall not result in loss of Council Member productivity, interference with official duties or incur additional expense to the Shire.

In all cases use must be reasonable as this use is a privilege, not a right.

Conditions of Use

The following uses of the Shire of Northam's computing or communication resources are prohibited:

- To store, transmit, publish, communicate, display, distribute or post material that is defamatory, offensive, abusive, indecent, menacing, unwanted or otherwise unlawful or unauthorised or that violates any law.
- To visit websites containing objectionable or criminal material.
- To use internet enabled activities such as gambling, conducting a business or conducting illegal activities.
- To knowingly transmit a computer virus or other malicious computer program
- To disclose private or confidential information of another.
- The uploading or downloading of commercial software, games, music videos, or other intellectual property in violation of its copyright.
- Accessing Shire data, a server or an account for any purpose other than conducting Shire business, even if the Elected Member has authorised access.
- Revealing account passwords to others or allowing use of their account by others. This includes family and other household members.

Non-compliance with this policy may result in disciplinary action in accordance with G 1.4 Code of Conduct for Councillors, Committee Members and Candidates, removal of access or legal action.



Shire of Northam Policy Manual (Section I)
Policy
G 1.17 Acceptable Use of the Shire's Computing & Communication
Resources – Council Staff

GOVERNANCE

G 1.17 Acceptable Use of the Shire's Computing & Communication Resources – Council Staff

<i>Responsible Department</i>	Chief Executive Officer
<i>Resolution Number</i>	C.4052
<i>Resolution Date</i>	21/10/2020
<i>Next Scheduled Review</i>	2022
<i>Related Shire Documents</i>	Various staff terms of appointment
<i>Related Legislation</i>	

OBJECTIVE

The purpose of this policy is to explain the acceptable use of the Shire's computer and communication resources.

SCOPE

All Council staff.

POLICY

Introduction

All network equipment, email and internet accounts maintained in the Shire of Northam's computing systems are the sole property of the Shire of Northam. The Shire records all internet usage and has the right to monitor the email account or internet browser of any user for legitimate business reasons including compliance with this policy, compliance with any applicable laws and where there is reasonable suspicion of activities that may not conform to this policy.

Scope

This policy applies to all Shire of Northam employees and volunteers that have access to or use of Shire of Northam computing and communication resources. These persons are expected to comply with this policy.



Shire of Northam Policy Manual (Section I)
Policy
G 1.17 Acceptable Use of the Shire's Computing & Communication Resources – Council Staff

General Obligations

This policy sets out the minimum acceptable behaviour for the use of the Shire's computing and communication facilities. There is a reasonable expectation that the parties included in the scope of this policy will act professionally and use these resources responsibly according to this policy.

Reasonable Personal Use

Council staff are permitted minimal additional personal use of the Shire of Northam provided information technology equipment. This personal use shall not result in loss of employee productivity, interference with official duties or incur other than minimal additional expense to the Shire. Examples of minimal additional personal use include making a few photocopies, using a computer printer to print a few pages of material, making occasional brief personal phone calls, infrequently sending personal email messages or limited use of the internet for personal reasons.

Council staff who are provided with mobile phones, tablets or laptops are granted the same minimal additional personal use, unless they receive written approval from the Chief Executive Officer for the minimal use to be granted to full private use. In the case of the Chief Executive Officer written approval will be provided by the Shire President.

In all cases use must be reasonable as this use is a privilege, not a right.

Conditions of Use

The following uses of the Shire of Northam's computing or communication resources are prohibited:

- To store, transmit, publish, communicate, display, distribute or post material that is defamatory, offensive, abusive, indecent, menacing, unwanted or otherwise unlawful or unauthorised or that violates any law
- To visit websites containing objectionable or criminal material
- To use internet enabled activities such as gambling, conducting a business or conducting illegal activities
- To knowingly transmit a computer virus or other malicious computer program
- To disclose private or confidential information of another
- The uploading or downloading of commercial software, games, music videos, or other intellectual property in violation of its copyright

Non-compliance with this policy may result in removal or accessor legal action.



GOVERNANCE

G 1.19 Public Interest Disclosure

<i>Responsible Department</i>	Governance
<i>Resolution Number</i>	C.4242
<i>Resolution Date</i>	16/06/2021
<i>Next Scheduled Review</i>	2022/23
<i>Related Shire Documents</i>	
<i>Related Legislation</i>	<p>Local Government Act 1995 Public Interest Disclosure Act 2003 Corruption Crime and Misconduct Act 2003 Standing Orders Local Law 2018 Public Sector Commission Code of Conduct Australian Standard for Whistle Blower Protection (AS8004:2003)</p>

OBJECTIVE

The Shire of Northam will receive disclosures of public interest information in accordance with the provisions of the Public Interest Disclosure Act 2003

SCOPE

This policy applies to:

1. all staff; and
2. elected members, who may need to lodge a Public Interest Disclosure (PID).

POLICY

The Shire of Northam does not tolerate corrupt or other improper conduct including mismanagement of public resources in the exercise of the public functions of the Shire of Northam and its elected members, officers, employees and contractors.

The Shire of Northam is committed to the aims and objectives of the *Public Interest Disclosure Act 2003* (PID Act). The Shire recognises the value and importance of contributions of employees to enhance administrative and management practices and strongly supports disclosures being made by employees as to corrupt or other improper conduct.

As a proper authority, the Shire of Northam is responsible for:

- receiving disclosures;
- investigating disclosures;



Shire of Northam Policy Manual (Section I)
Policy
G 1.19 Public Interest Disclosure

- taking appropriate action; and
- reporting.

The Shire of Northam will take all reasonable steps to provide protection to employees who make such disclosures from any detrimental action in reprisal for the making of a public interest disclosure.

The Shire of Northam does not tolerate any of its officers, employees or contractors engaging in acts of victimisation or reprisal against those who make public interest disclosures.

The persons responsible for receiving disclosures of public interest information designated under s. 23(1)(a) of the PID Act will abide by the *PID Code of conduct and integrity* in performing their duties.

The Shire of Northam is also committed to responding to the disclosure thoroughly and impartially and will treat all people in the disclosure process fairly, including those who may be the subject of a disclosure.

These internal procedures are accessible to all employees and contractors. Copies are available from the designated person appointed as Public Interest Disclosure (PID) Officer and will be kept on Promapp.

<https://au.promapp.com/shireofnortham/Process/Minimode/Permalink/E2JXaSCOV5POvhrJ7hAJfS>



Shire of Northam Planning Policy Manual (Section I)
Policy
G 1.20 Organisational Structure Policy

GOVERNANCE

G 1.20 Organisational Structure

<i>Responsible Department</i>	CEO Office
<i>Resolution Number</i>	C.4236
<i>Resolution Date</i>	16/06/2021
<i>Next Scheduled Review</i>	2022/23
<i>Related Shire Documents</i>	
<i>Related Legislation</i>	Local Government Act 1995, section 5.2

OBJECTIVE

To provide guidance to the Council and the Chief Executive Officer concerning the Organisational Structure for the Shire's administration, including the management of functional responsibilities and the allocation and management resources within the structure

SCOPE

The Policy applies across the organisation.

POLICY

1. Determination of Organisational Structure

In accordance with the Local Government Act 1995 Section 5.2, Council determines that the organisational structure of the Shire of Northam shall be:



Shire of Northam Planning Policy Manual (Section I)
Policy
G 1.20 Organisational Structure Policy

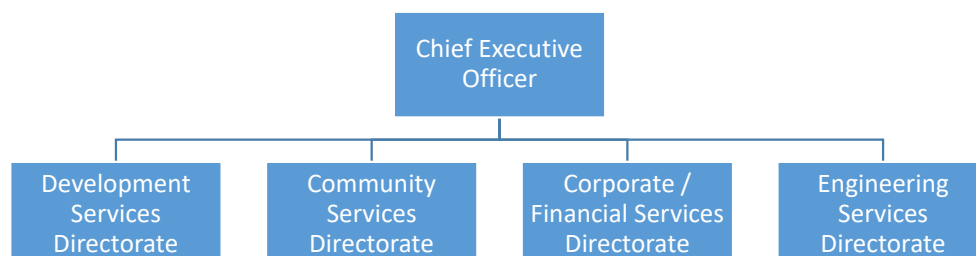

a) Determining Organisational Sub-Structure

To ensure the efficient, effective, and orderly administration of the Shire, the Chief Executive Officer shall, within established budget parameters, determine:

- i. the operational responsibilities of each of the Directorates and the subsequent substructure sections within the respective Directorates to fulfil these responsibilities; and
- ii. the sub-structure of each Section including the number of full-time equivalent positions required to ensure the efficient and effective delivery of operational outcomes.

b) Council's Satisfaction with Organisational Structure

If the Council is not satisfied that an appropriate structure exists, the Council may, by resolution, request the CEO to review the structure.

c) Corporate Plan Reporting

The Annual Corporate Business Plan of the Shire of Northam will provide a detailed organisational structure. The Corporate Business Plan will clearly indicate any changes in staff numbers over previous years, by Directorate.



GOVERNANCE

G 1.X Council Members Leave of Absence

<i>Responsible Department</i>	CEO Office
<i>Resolution Number</i>	TBC
<i>Resolution Date</i>	TBC
<i>Next Scheduled Review</i>	2024/25
<i>Related Shire Documents</i>	Nil
<i>Related Legislation</i>	<i>Local Government Act 1995, Section 2.25</i>

OBJECTIVE

To provide guidance and criteria for Council Members to include in applications for leave of absence from attending to Council related duties and responsibilities, pursuant to Section 2.25 of the *Local Government Act 1995*.

SCOPE

This policy applies to all Shire of Northam Council Members.

POLICY

1. Applications by Council Members for formal Leave of Absence from Council commitments are to be provided in writing to the CEO.
2. Applications are required to include the following information, as a minimum:
 - 2.1 Period of Leave sought (dates from beginning to end).
 - 2.2 Reason for Absence (e.g. Holiday, Health, Work Related).
 - 2.3 Expected number of Ordinary Council Meetings held during applicable period of leave.
 - 2.4 Any Meetings, Briefings or other functions conducted by the Shire during the requested period of leave which the member expressly wishes to attend.
3. Any application for a period of leave will be presented to a Council Meeting for consideration, as soon as practicable, to ensure the matter is dealt with in a timely manner.
4. All applications will be subject to an officer recommendation which addresses whether:
 - 4.1 The application conforms with the requirements of (1) and (2) above.

G.X Elected Members Leave of Absence



Shire of Northam Planning Policy Manual (Section I)
Policy
G 1.X Council Members Leave of Absence

- 4.2 The details and reasons provided in the application are considered valid.
5. The Council Member is expected to be absent from all Shire related commitments during the applicable period, including Ordinary Council Meetings, except for those to which the Council Member has already notified their attendance in advance.
6. Where the Council Member does not have leave approved in advance for a Council or Committee meeting, the member is to be recorded as an apology for that meeting.



ADMINISTRATION

A 8.3 Records Management

<i>Responsible Department</i>	CEO Office
<i>Resolution Number</i>	TBC
<i>Resolution Date</i>	TBC
<i>Next Scheduled Review</i>	2024
<i>Related Shire Documents</i>	Record Keeping Plan Policy G 1.9 Council Member and Staff Interactions and Requests for Information
<i>Related Legislation</i>	State Records Act 2000 Criminal Code Act 1913 Corruption and Crime Commission Act 2003 Electronic Transactions Act 2011 Evidence Act 1906 Financial Management Act 2006 Freedom of Information Act 1992 Interpretation Act 1984 Limitations Act 2005 Local Government Act 1995 State Records Commission: Principles and Standards Australian Standard on Records Management: AS ISO 15489

OBJECTIVE

To define the principles that underpin the Shire's record keeping function and the roles and responsibilities of those individuals who manage or perform record keeping processes on behalf of the Shire.

The Policy and its associated Plans and Procedures establish a framework for the reliable and systematic management of Shire records in accordance with legislative requirements and best practice standards.

SCOPE

This policy applies to all government records created or received by a Shire of Northam employee, contractor or Council Member, or an organisation performing outsourced services on behalf of the Shire of Northam, regardless of their physical format, storage location or date of creation.



POLICY

Custodianship of Records

The Shire of Northam recognises its records as a government owned asset and will ensure that they are managed as such. Ownership and proprietary interest of records created or collected during the course of business (including those from outsourced bodies or contractors) is vested in the Shire of Northam.

Roles and Responsibilities

- (a) **Council Members:** All Council Members are to create, collect and retain records relating to their role as a Council Member for the Shire of Northam in a manner commensurate with legislation and the Shire's policies and procedures for record keeping. Originals or copies thereof shall be delivered to the Chief Executive Officer for recording and safe keeping by the Shire of Northam. Party political and personal records of Council Members are exempt.
- (b) **Chief Executive Officer:** The Chief Executive Officer is to ensure that an organisational system for the capture and management of records is maintained that is compliant with legislative requirements and best practice standards.
- (c) **Managers:** All Managers are to ensure record keeping policy and procedures are known and adhered to in their area of responsibility.
- (d) **All Staff:** All staff (including contractors) are to create, collect and retain records relating to Shire of Northam business activities they perform. They are to identify significant and ephemeral records, ensure significant records are captured into the Record Keeping System and that all records are handled in a manner commensurate with legislation and the Shire's policies and procedures for record keeping.

Creation of Records

All Council Members, staff and contractors will create full and accurate records, in the appropriate format, of the Shire's business decisions and transactions to meet all legislative, business, administrative, financial, evidential and historical requirements.

Capture and Control of Records

All records created and received in the course of Shire of Northam business are to be captured at the point of creation, regardless of format, with required metadata (naming conventions as per the Document Control in Promapp), into appropriate record keeping and business systems that are managed in accordance with sound record keeping principles.

Security and Protection of Records

All records are to be categorised as to their level of sensitivity and adequately secured and protected from violation, unauthorised access or destruction, and kept in accordance with necessary retrieval, preservation and storage requirements.



Access to Records

Access to the Shire's records by staff and contractors will be in accordance with designated access and security classifications. Access to the Shire's records by the general public will be in accordance with the *Freedom of Information Act 1992* and Shire policy. Access to the Shire's records by Council Members will be via the Chief Executive Officer in accordance with the *Local Government Act 1995* and Policy G 1.9 Council Member and Staff Interactions and Requests for Information.

Appraisal, Retention & Disposal of Records

All records kept by the Shire will be disposed of in accordance with the General Disposal Authority for Local Government Records, produced by the State Records Office of Western Australia in 1999.



ADMINISTRATION

A 8.4 Complaints Management

<i>Responsible Department</i>	Executive Manager Corporate Services
<i>Resolution Number</i>	TBC
<i>Resolution Date</i>	TBC
<i>Next Scheduled Review</i>	2024/25
<i>Related Shire Documents</i>	Customer Service Charter Record Keeping Plan Policy G 1.4 Code of Conduct for Councillors, Committee Members and Candidates Policy G 1.15 Code of Conduct – Employees, Volunteers, Contractors and Agency Staff Policy G 1.19 Public Interest Disclosure Policy A 8.3 Records Management
<i>Related Legislation</i>	Local Government Act 1995 State Records Act 2000 Freedom of Information Act 1992 Australian Standard Guidelines for complaints management in organisations (ISO:10002:2022)

OBJECTIVE

The objectives of the Complaints Management Policy (policy) are to:

1. Ensure complaints are managed in accordance with best practice as outlined by the Australian Standard for Complaints Management ISO 10002:2022 – Guidelines for complaint management in organisations, and the Western Australian (WA) Ombudsman Guidelines on Complaint Handling;
2. Ensure that the complaints received by the Shire of Northam (the Shire) are managed effectively and fairly from the time of receipt through to a satisfactory resolution or final determination of the matter; and
3. Support a culture of continuous improvement, by valuing the opportunity to identify business improvements and increase the levels of satisfaction with the delivery of services.

This policy is underpinned by a Complaints Management Framework.

SCOPE

This policy applies to all complaints received from customers relating to:



- A Shire service, process, product, policy, event or facility.
- The services provided by the Chief Executive Officer (CEO), a Shire employee, volunteer, contractor, Council Member or committee member.
- A third party under the jurisdiction of the Shire.

This policy does not apply to:

- Employment or behavioural/conduct of Shire employees or CEO – refer to Policy G 1.15 Code of Conduct – Employees, Volunteers, Contractors and Agency Staff.
- Behavioural/conduct related complaints regarding volunteers or contractors– refer to Policy G 1.15 Code of Conduct – Employees, Volunteers, Contractors and Agency Staff.
- Behavioural/conduct of Council Members, Committee Members or Candidates – refer to Policy G 1.4 Code of Conduct for Councillors, Committee Members and Candidates.
- Public Interest Disclosure – Refer to Policy G 1.19 Public Interest Disclosure.

POLICY

1. Definitions

Shire means Shire of Northam.

Complaint means any “Expression of dissatisfaction made to or about an organisation, related to its products, services, staff or the handling of a complaint, where a response or resolution is explicitly or implicitly expected or legally required” (ISO 10002:2022).

A complaint is not:

- The initial requests for a service or action by the Shire (unless there was inaction or an unsatisfactory response to the initial request for service).
- Feedback on a service where there is not an issue to be resolved or does not necessitate action by the Shire.
- Feedback obtained during stakeholder and community engagement processes
- Requests for information or explanations of policies, procedures or decisions of Council
- Reports of damaged, faulty infrastructure or a hazard
- Reports concerning neighbours or neighbouring property
- The lodging of an appeal or an objection in accordance with policy or procedure
- A petition
- A civil dispute between private individuals
- Made on social media or letters to the editor
- Matters regarding State or Federal Government or matters not within the Shire's jurisdiction.

Complaints Management Framework refers to the policies, procedures, processes, practices, staff and systems involved in the managing of complaints across the Shire.



Customer refers to a person who is accessing the Shire's services, facilities, policies, products, programs or events.

2. Principles of complaint management

The following complaints management principles apply:

- a. Complaints are people focused, transparent and accessible to all:
 - i. **People Focus:** the Shire will be proactive in listening and responding to complaints, treating all people with respect, and actively involving them in the complaints process as far as practicable and appropriate.
 - ii. **Visible & Transparent:** the Shire will actively publicise information about how and where to complain and make it easy to understand what to expect.
 - iii. **Accessible:** the Shire will ensure that our complaint handling process is accessible and easy to use for all our customers.
- b. Complaints are managed in an efficient, fair and equitable manner:
 - i. **Responsive:** the Shire will respond to all complaints as quickly as possible and endeavour to regularly communicate and inform parties involved.
 - ii. **Objective and Fair:** the Shire will review all complaints in an equitable, fair and unbiased manner using evidence submitted by both the complainant and officers.
 - iii. **Equality and Privacy:** the Shire will be consistent and ethical in our treatment of complaints and customers involved.
- c. Complaints are managed in a supported manner:
 - i. **Conduct:** the Shire will work together to resolve problems respectfully and cooperatively and as far as practical maintain the confidentiality of all parties.
 - ii. **Empowerment:** the Shire will continually work to improve the complaint management process to meet operational needs and the expectations of customers, including providing support to vulnerable people, people with disability, indigenous people, young people and culturally and linguistically diverse people.
 - iii. **Facilitate:** the Shire will work together to reach a solution that provides the best outcome for all parties wherever practical and actively communicate with all involved
- d. Complaints are used as an opportunity to improve services:
 - i. **Accountability:** the Shire will ensure that our staff are aware of and accountable for complaints.
 - ii. **Learning:** the Shire will respond to and learn from complaints with the intention to continually improve our services
 - iii. **Prevention:** the Shire will effectively report on and analyse complaints to identify trends and endeavour to minimise the escalation of complaints.



*Shire of Northam Policy Manual (Section I)
Policy
A 8.4 Complaints Management*

The Shire will maintain a complaints management process as part of its Complaints Management Framework to ensure that the above principles are applied for the management of all complaints.



ADMINISTRATION

A 8.5 Property Management (Leases and Licences)

<i>Responsible Department</i>	Corporate Services
<i>Resolution Number</i>	TBC
<i>Resolution Date</i>	TBC
<i>Next Scheduled Review</i>	2024/25
<i>Related Shire Documents</i>	
<i>Related Legislation</i>	Local Government Act 1995 s3.58 Local Government Act 1995 s9.49A(2)&(4) Local Government (Functions and General) Regulations 1996 Reg 30(2)(b)

OBJECTIVE

To provide principles to ensure that all requests to lease or licence Shire of Northam owned, managed or controlled property, including Crown land, are dealt with in a fair, equitable, and where possible, a consistent manner.

To minimise the risk to the Shire of Northam and to maximise the overall return to the community for Shire of Northam assets.

To ensure compliance with the Local Government Act 1995 and any other relevant laws, and consistency with Shire of Northam policies.

SCOPE

The Policy applies to the leasing and licensing of all property owned, managed or controlled by the Shire of Northam, including Crown land.

POLICY

The Shire of Northam as legal owner of Property may from time to time choose to enter into a Lease or Licence agreement with a third party. The disposal of land is covered under the Local Government Act 1995 and the Local Government (Functions and General) Regulations 1996.

The Shire of Northam also manages some Reserves which are available for leasing and licensing purposes for specific periods and purposes as set by the Crown.



This Policy recognises the variety and diversity of leases and licences and seeks to ensure that all lessees/licensees and prospective lessees/licensees have an understanding of the underlying elements of this Policy.

All requests for a lease or licence will be determined:

- in a fair, transparent, and where possible, consistent way; and
- in a manner that complies with statutory principles and policy.

The Shire of Northam will always seek to comply with the following principles in dealing with property, bearing in mind that variation may be required given the varying nature of each property and lessee/licensee and the current state of the leasing and licencing market.

The Shire of Northam reserves its right to exercise its discretion in all circumstances and remains bound by all applicable Laws and Regulations.

1. Type of Agreement

- 1.1 A Lease will be entered into where the intention is to grant exclusive possession of the property or part of the property.
- 1.2 A Licence will be entered into where the intention is to grant non- exclusive possession of the property or part of the property.

2. Term

- 2.1 As a general principle, a new lease will be limited to a maximum of a five (5) year term and any option to renew will be limited to no more than a five (5) year term. Council may consider longer terms where Council is of the opinion that there is benefit or merit for providing a longer lease term.
- 2.2 The maximum tenure of a Lease or Licence granted by the Shire on Crown land will be consistent with the term of the management order including any further term option/s.
- 2.3 The term will depend on many factors, including but not limited to:
 - 2.3.1 The needs of Council and Council Plan objectives.
 - 2.3.2 The needs of the community.
 - 2.3.3 The Lessee.
 - 2.3.4 The Business.
 - 2.3.5 The ongoing need for the property or the provided use.
 - 2.3.6 Substantial contributions to capital or structural works by the lessee.
 - 2.3.7 The sustainability of the lessee.
 - 2.3.8 The sustainability of the property.



- 2.3.9 The Management Order for the Property (if Crown land) and the requirements of the Minister for Lands.
- 2.3.10 The current state of the leasing and licencing market.

3. Planning, Consent & Approvals

- 3.1 Planning Approval (if required) must be obtained from the Shire as the local planning authority prior to a lease or licence being entered into.
- 3.2 Where the Shire manages Crown land, grant of the lease or licence and each renewal, if any, will be conditional on Minister for Lands approval.
- 3.3 The lessee or licensee is solely responsible for obtaining all approvals, licenses and authorities necessary to conduct the proposed activities on any premises. The Shire makes no representation that a premises or property is suitable for any activity, whether permitted or otherwise.

4. Sub-letting

- 4.1 A Lessee or Licensee must not sub-Lease, sub-Licence or part with possession of Property that is the subject of a Lease or Licence without the Shire's prior written consent. The Lessee will be required to prove the suitability of a sub-Lessee/sub-Licensee.
- 4.2 Sub-Leases and sub-Licences must be consistent with the head Lease or Licence purpose. If the purpose is inconsistent, a variation to the head Lease or Licence will be required to accommodate the sub-Lease or sub-Licence purpose.
- 4.3 If sub-Leasing or sub-Licensing Shire managed buildings, the Lessee or Licensee cannot charge a rent for the sublet area that is pro-rata higher than the rent payable under the head Lease or Licence.
- 4.4 If sub-Leasing or sub-Licensing buildings constructed by the Lessee on Shire owned and or Shire managed land, the Lessee can determine the sub-Lease or sub-Licence rental provided that the Shire is satisfied that such rental is reasonable and in line with the capital investment in the property.

5. Assignment

- 5.1 A Lessee or Licensee must not assign a Lease or Licence without the Shire's prior written consent, which may be withheld in the Shire's absolute discretion. Assignors continue to be liable for the remainder term of the Lease and will be required to prove suitability of an assignee.

6. Variations



6.1 The Shire will consider variation requests on a case-by-case basis. All requests must be receiving in writing with appropriate justification.

7. Vacant Property

7.1 Unless extenuating circumstances are deemed by the Shire to apply, the Shire will conduct an Expression of Interest (EOI) process to determine a suitable Lessee for vacant Shire Property.

7.2 The decision to conduct an EOI process will be based on factors including but not limited to:

- a. The size of the Property
- b. The location of Property
- c. The value of Property
- d. The expected rental return
- e. The likelihood of multiple interested users
- f. Ensure the Lessee delivers specific services
- g. Allow for innovative or flexible solutions for the property

8. Essential Terms

8.1 Community Lease or Licence to manage community halls (excluding Northam Memorial Hall)	
Initial Term	Five (5) years
Option	Five (5) years (at the Shire's discretion)
Responsibilities of Tenant	<ol style="list-style-type: none"> a. Lessees or Licensees must agree with Council to manage the Property on behalf of the community and to offer a service to the community that provides a net benefit. b. Lessees or Licensees will be responsible for minor maintenance obligations. <ol style="list-style-type: none"> a. The Lessee or Licensee will be responsible for the cost of repair of any internal damage, vandalism, corrective maintenance or damage to external doors, glass windows, security lighting and any other external facility through misuse by a club representative or member. The Shire may carry out any corrective works and recoup the full cost from the Lessee or Licensee. b. The Lessee or Licensee will be responsible for keeping the building clean and tidy at levels predetermined within the agreement. c. The Lessee or Licensee will not incur any costs for property damage excluding contents occasioned by



Shire of Northam Policy Manual (Section I)
Policy
A 8.5 Management of Council Property Leases

	<p>fire, fusion, explosion, lightning, civil commotion, storm, tempest, or earthquake.</p> <p>d. The Lessee or Licensee agree to meet with the Shire representatives on an annual basis to carry out a property inspection to determine the extent to which the Lessee or Licensee have met their lease/licence obligation and to consider any specified building maintenance schedules for the following twelve month period within the Shire's budget parameters.</p>
Responsibilities of the Shire	<p>a. The Shire will assist in maintaining the facility for the benefit of the community, with the Community Group as manager;</p> <p>b. The Shire will cover the cost of building insurance and the lease preparation fee.</p> <p>c. The Shire through the Council's annual budget process will provide a maximum amount of \$1,000 per annum, towards the maintenance of the special floor surface in the sports arena section of the Bakers Hill Recreation Centre.</p>
Outgoings payable by tenant	<p>The Lessee or Licensee will not be responsible for Shire land rates but will be responsible for all other charges and taxes levied against the Property, including but not limited to water, sewerage, waste disposal, telephone, gas and electricity.</p>
Tenancy Fee	<p>\$1.00 per annum to reflect the community contribution of the group.</p>

8.2 Community Lease or Licence	
Initial Term	Five (5) years
Option	Five (5) years (at the Shire's discretion)
Responsibilities of Tenant	<p>a. Lessees or Licensees must agree with Council to manage the Property on behalf of the community and to offer a service to the community that provides a net benefit.</p> <p>b. Lessees or Licensees will be responsible for minor maintenance obligations.</p> <p>c. The Lessee or Licensee will be responsible for the cost of repair of any internal damage, vandalism, corrective maintenance or damage to external doors, glass windows, security lighting and any other external facility through misuse by a club representative, member or guest. The Shire may carry out any corrective works and recoup the full cost from the Lessee or Licensee.</p>



Shire of Northam Policy Manual (Section I)
Policy
A 8.5 Management of Council Property Leases

	<p>d. The Lessee or Licensee will be responsible for keeping the building clean and tidy at levels predetermined within the agreement.</p> <p>e. The Lessee or Licensee will not incur any costs for property damage excluding contents occasioned by fire, fusion, explosion, lightning, civil commotion, storm, tempest, or earthquake.</p> <p>f. The Lessee or Licensee agree to meet with the Shire representatives on an annual basis to carry out a property inspection to determine the extent to which the Lessee or Licensee have met their lease/licence obligation and to consider any specified building maintenance schedules for the following twelve month period within the Shire's budget parameters.</p>
Responsibilities of the Shire	<p>a. The Shire will insure the Property at replacement value and pass on the cost to the Lessee or Licensee as the Tenancy Fee.</p> <p>b. The Shire will be responsible for any electrical wiring or structural repairs/improvements in accordance with levels determined within its budget forecast. In the case of the Lessee or Licensee who leases a Council building and obtains approval to carry out extensions, alterations and/or additions, Council will insure the improvements as part of its insurance portfolio at replacement value.</p>
Outgoings payable by tenant	<p>a. The Lessee or Licensee will not be responsible for Shire land rates but will be responsible for all other charges and taxes levied against the Property, including but not limited to water, sewerage, waste disposal, telephone, gas and electricity.</p> <p>b. Lessees or Licensees will be responsible for the full cost of the lease document preparation, registration and other costs associated with the execution of the agreement.</p> <p>c. The Lessee or Licensee will be responsible for contents insurance for their contents, and also hold public liability for their activities and workers compensation insurance for their employees (if applicable).</p>
Tenancy Fee	An amount equivalent to the cost of building insurance to be reviewed annually.

8.3 Commercial Lease or Licence / Subsidised Community Lease or Licence	
Initial Term	Five (5) years
Option	Five (5) years (at the Shire's discretion)



Shire of Northam Policy Manual (Section I)
Policy
A 8.5 Management of Council Property Leases

Responsibilities of Tenant	<p>a. Cost of repair for any internal damage, vandalism, corrective maintenance or damage to external doors, glass windows, security lighting and any other external facility through misuse by a member of staff, representative or guest. The Shire may carry out any corrective works and recoup the full cost from the Lessee or Licensee.</p> <p>b. In the case of Lessee or Licensee obtaining approval to carry out extensions, alterations and/or additions, Council will insure the improvements as part of its insurance portfolio at replacement value.</p>
Responsibilities of the Shire	<p>a. The Shire will insure the Property at replacement value and perform any structural repairs, improvements and maintenance in accordance with the level stipulated in the agreement.</p>
Outgoings payable by tenant	<p>a. All outgoings including rates, charges and taxes levied against the Property, including but not limited to water, sewerage, waste disposal, telephone, gas and electricity.</p> <p>b. Insurance premiums for the Property as recovered by the Shire. The Lessee will reimburse the Shire for any excess in respect of any claim.</p> <p>c. The Lessee or Licensee will be responsible to meet the full cost of the document preparation, registration and other costs associated with the execution of the agreement.</p> <p>d. The Lessee or Licensee will be responsible for contents insurance for their contents, and also hold public liability for their activities and workers compensation insurance for their employees (if applicable).</p>
Tenancy Fee	<p>a. The tenancy fee will be consistent with market valuation and be subject to rent reviews on the anniversary date. The costs of obtaining a Market Valuation (provided by a licensed Property Valuer appointed by the Shire) for the initial Lease or Licence rental assessment and during the term of the Lease or Licence will be paid by the Lessee.</p> <p>b. The Shire recognises that partnerships can be entered into for the benefit of the local community and acknowledges the adopted lease or licence rent will be determined on a case by case basis taking into consideration:</p> <ol style="list-style-type: none"> i. Land contribution; ii. Building cost contribution; iii. State or Federal legislation; and iv. Level of benefit to local community.



8.4 Airport Hangar Lease or Licence	
Initial Term	All agreements will have a common expiry and the term will be determined based upon the current common expiry.
Option	Five (5) years unless otherwise determined to ensure common expiry is achieved.
Responsibilities of Tenant	<ul style="list-style-type: none"> a. All improvements, repairs and maintenance to the Property are the sole responsibility of the Lessee or Licensee. b. The Lessee or Licensee will be responsible for lodging a development application for new hangars. A Lease or Licence will not be entered into until approval has been granted. c. To comply with all lawful requirements of the Civil Aviation, Safety Authority or other body or department regulating and relating to the flying of aircrafts and to comply with all Acts of Parliament and regulations relating thereto.
Responsibilities of the Shire	<ul style="list-style-type: none"> a. The Shire of Northam will appoint a manager who will be responsible for the day-to-day operations of the Northam Airport.
Outgoings payable by tenant	<ul style="list-style-type: none"> a. All outgoings including rates, charges and taxes levied against the Property, including but not limited to water, sewerage, waste disposal, telephone, gas and electricity. b. The Lessee or Licensee will be responsible to meet the full cost of the document preparation, registration and other costs associated with the execution of the agreement. c. The Lessee or Licensee will be responsible to contribute to the full cost of any previous improvements to the Airport by way of a levy proportioned to the cost of the work by a once-off lease establishment fee or transfer fee as set in the Shire of Northam Fees and Charges. d. Building and contents insurance and also hold current public liability insurance and worker compensation (if applicable).
Tenancy Fee	\$5.50 per square metre for recreational hangar sites and \$6.00 per square metre for commercial hangar site.

8.5 Pop Up Shop Lease or Licence	
Initial Term	Three (3) months



Option	A further option of three (3) months may be granted should a subsequent tenant not be identified.
Responsibilities of Tenant	<ul style="list-style-type: none"> a. Not to do anything or permit anything to be done to or in the Premises which is a nuisance or annoyance to the Licensor or the occupier of any adjoining or neighbouring premises; b. The Lessee or Licensee will be responsible for keeping the building clean and tidy at levels predetermined within the agreement. c. Not make or permit to be made any alterations or additions whatsoever in or to the Premises or any part thereof without first obtaining the written consent of the Shire. d. Maintain opening hours of not less than five (5) days each week which days must include weekends and such other days where there are events to be held in Northam.
Responsibilities of the Shire	a. The Shire will be responsible for any minor maintenance and structural repairs/improvements in accordance with levels determined within its budget forecast.
Outgoings payable by tenant	a. Contents insurance, public liability insurance and worker compensation insurance (if applicable).
Tenancy Fee	As determined by the Shire of Northam based on the average cost of outgoings.

DEFINITIONS

In this policy, the following definitions apply:

Act	The Local Government Act 1995 as amended.
Shire	Shire of Northam
Commercial Lease or Licence	In this Policy, a legally binding agreement, relating to all Leases other than a Community Lease or a Subsidised Community Lease.
Community Based not-for-profit Lease or Licence	A legally binding agreement granted to a community, sporting or recreation associations or other non-government organisations that provides a service or activity for the benefit of the community and does not operate for the profit, personal gain or other benefit of its members or third parties and which applies all proceeds from its activities to the organisation's purposes.
Consumer Price Index	The weighted average cost of a standard basket of retail goods expressed in relation to a base period for Perth (All groups).
Crown Land	Land owned by the Crown and vested in the Shire of Northam through the granting of a Management Order.



Delegated Authority	In accordance with the provisions of Section 5.42 of the Local Government Act 1995, Council may delegate authority to the Chief Executive Officer to exercise certain powers or duties to enable the continued working of Council without the necessity for reporting to an Ordinary Council Meeting. Delegated Authority Reference F06 relates to the authority granted by Council for disposing of property by lease or licence.
Incorporated	A group of people who are recognised as a legal entity, separate from individual members as defined under the Associations Incorporation Act (1987).
Lease	A legally binding agreement by which one party (Lessor) in consideration of rent, grants exclusive use and possession of real Property to a third party (Lessee) for a specified purpose and term. A Lease creates an interest in the Property.
Lease or Licence Variation	The addition, removal or change of one or more of the Lease or Licence provisions.
Lessee	An authorised third party that has entered into a Lease or Licence with the Shire of Northam for the use of Shire of Northam owned or managed real Property and pays rent to occupy the Property (and where the context permits includes a Licensee).
Lessor	The Shire of Northam being the owner or management body of Property with power to Lease or Licence to a third party (Lessee).
Licence	Permits a person to occupy Property, or part thereof on particular conditions. The main feature that distinguishes a Licence from a Lease is that a Licence does not permit exclusive use of the Property, and may be used by others. A Licence does not create an interest in the Property.
Licensee	A person that holds an approved Licence. For the purpose of this document (where context permits) a Licensee will also be referred to as "Lessee".
Management Order	An authorisation provided by the Crown giving the Shire of Northam both the power and authority to manage a parcel of land on behalf of the Crown.
Market Valuation	A valuation determined by a licensed Valuer registered with the Australian Property Institute taking into consideration a range of factors to determine the current market rental value of a Property.
Minimum Rate	The rate set annually by Council in its absolute discretion as the minimum rate chargeable for rateable Property.
Planning Scheme Consent	Local Planning Approval requirement if proposing to change a land use, develop or use any land including the erection, construction or alteration of any building, excavation or other works on any land.
Property	The Property that is subject to or intended to be subject to a Lease or Licence.



Shire of Northam Policy Manual (Section I)
Policy
A 8.5 Management of Council Property Leases

Regulations	Local Government (Functions and General) Regulations 1996.
Reserve	A defined area of land belonging to the Crown which has been vested in the Shire of Northam by way of a Management Order.
Subsidised Community Lease or Licence	A legally binding agreement granted to a not-for-profit entity delivering a community social service with the assistance of a Commonwealth or State Government operating grant and/or qualify for charitable status under the Charities Act 2013 (Cth).

13.2 ENGINEERING SERVICES

Nil.

13.3 DEVELOPMENT SERVICES

13.3.1 Proposed Scheme Amendment 18 - 54 Byfield St, Northam

File Reference:	3.1.10.18 / A10217
Reporting Officer:	Jacky Jurmann (Acting Executive Manager Development Services)
Responsible Officer:	Jacky Jurmann (Acting Executive Manager Development Services)
Officer Declaration of Interest:	Nil
Voting Requirement:	Simple Majority
Press release to be issued:	No

BRIEF

Council at its Ordinary Meeting held on 16 November 2022 resolved to initiate Scheme Amendment 18 to recode Lot 100 (No. 54) Byfield Street, Northam from R15 to R20 and amend the scheme map accordingly.

The amendment has been advertised in accordance with the provisions of the *Planning and Development (Local Planning Schemes) Regulations 2015* and a number of submissions have been received in response.

The purpose of this Report is for Council to consider formally adopting the scheme amendment.

ATTACHMENTS

1. Scheme Amendment Document - S A 18 [**13.3.1.1** - 33 pages]
2. EPA Notice of Decision [**13.3.1.2** - 2 pages]
3. Schedule of Submissions SA18 PUBLIC [**13.3.1.3** - 1 page]
4. CONFIDENTIAL REDACTED - Schedule & Submissions CONFIDENTIAL [**13.3.1.4** - 19 pages]

A. BACKGROUND / DETAILS

Background

The subject property is located on the corner of Byfield and East Streets, is vacant and has a residential coding of R15.

As indicated in the Scheme Amendment document, two subdivision approvals (refs: 155540 and 162419) have been granted by the Western Australian Planning Commission to create 43 residential lots plus 1 residue lot, in conjunction with lots 105, 106 and 107 Frankish Road, utilising the existing coding.

Details

It is proposed to recode Lot 100 to R20 to be consistent with the other lots in the development to facilitate a potential lot yield of 16 lots, when compared to 10 lots under the current coding.

Table 1 of the State Planning Policy 7.3 – Residential Design Codes Volume 1 stipulates lot size using density codes, known as R-Codes. The R15 R-Code has a minimum lot size of 580m² with an average lot size of 666m²; and the R20 R-Code has a minimum lot size of 350m² with an average lot size of 450m². A copy of the R-Codes Table is attached to this Report (Attachment 2).

If the scheme amendment is approved, the subdivision layout will be revised as depicted in Annexure 2 of the Scheme Amendment document (Attachment 1) that will increase lot yield providing additional lots for the local residential market.

B. CONSIDERATIONS

B.1 Strategic Community / Corporate Business Plan

Performance Area: Place.

Outcome 7: Urban and rural communities are sensibly planned and developed.

Objective 7.1: Provide sufficient land and development opportunities to enable local communities to grow.

Priority Action 7.1.5: Facilitate infill development in local towns via the Local Planning Scheme.

B.2 Financial / Resource Implications

The application and advertising fees will be borne by the Applicant.

B.3 Legislative Compliance

Planning and Development (Local Planning Schemes) Regulations 2015 Section 75 of the *Planning and Development Act 2005* (the Act) gives a local government the power to amend its local planning scheme. The procedure for preparing and adopting an amendment is provided for by the *Planning and Development (Local Planning Schemes) Regulations 2015* (the Regulations).

Should Council resolve to initiate the amendment (Reg. 35(1)), it must specify whether, in its opinion, the amendment is a complex, standard or basic amendment (Reg. 35(2)(a)). Council's resolution must also include an explanation of the reason for Council forming that opinion (Reg. 35(2)(b)), which is discussed in Officer's Comments below.

Following initiation, the amendment was referred to the Environmental Protection Authority (EPA) for its consideration under section 48A of the *Environmental Protection Act 1986*. The EPA determined not assess the proposal. Refer to Attachment 2 for a copy of the EPA's correspondence.

The amendment was then advertised in accordance with Reg. 47(3) and Reg. 76A as outlined in Consultation section and the submissions have been considered.

The amendment is now presented to Council for final adoption without modification for endorsement prior to requesting approval from the Western Australian Planning Commission.

B.4 Policy Implications

There are no policy implications for the Shire in relation to the recommendations of this Report.

B.5 Stakeholder Engagement / Consultation

The amendment was advertised to the community, nearby landowners and relevant government agencies for a minimum period of 42 days in accordance with the provisions of the Regulations.

Advertising included direct mail and email notifications with the documents made available for viewing on the Shire's website. A hard copy was also available on request.

Eight (8) submissions were received in response to the advertising – 7 from government agencies and 1 from an adjoining landowner. The issues raised in the submissions have been considered as detailed in the Schedule of Submissions (refer to Attachment 3).

B.6 Risk Implications

Risk Category	Description	Rating (likelihood x consequence)	Mitigation Action
Financial	Nil	Nil	Nil
Health & Safety	Nil	Nil	Nil
Reputation	Nil	Nil	Nil
Service Interruption	Nil	Nil	Nil

Compliance	Not following due process.	Minor (2) x Low (4) = Unlikely (2)	Ensure the process is correctly followed.
Property	Nil	Nil	Nil
Environment	Nil	Nil	Nil

B.7 Natural Environment Considerations

There are no natural environment considerations associated with this proposal.

C. OFFICER'S COMMENT

The issues raised in the submission have been considered and it is the Officer's recommendation that the proposal be endorsed without modification.

As indicated in the Schedule of Submissions, the issues raised by the adjoining landowners can be addressed at the time of subdivision, which is the normal timing to address such issues.

It is standard practice to require developers to maintain pre-development stormwater runoff flows to ensure that there are no impacts on downstream neighbours.

The re-coding of the lot is consistent with the other lots in the development area and will facilitate an additional potential 16 lots that will in turn provide an additional 16 dwellings located in a central location in the Northam townsite.

The amended subdivision layout (refer Concept Plan in Attachment 1) resulting from approval of the scheme amendment is also an improvement when compared to the original proposal.

If Council resolves to endorse the scheme amendment for approval, it will be forwarded to the WAPC for final approval.

RECOMMENDATION / COUNCIL DECISION

Minute No: C.4692

Moved: Cr A J Mencshelyi

Seconded: Cr H J Appleton

That Council SUPPORTS Amendment 18 to Shire of Northam Local Planning Scheme No. 6 without modification, pursuant to Regulation 50(3) of the Planning and Development (Local Planning Schemes) Regulations 2015, included in Attachment 1, for submission to the Western Australian Planning Commission.

CARRIED 8/0

One member of the gallery, Mr K Nieuwoudt, left the meeting at 5:51 pm

PLANNING AND DEVELOPMENT ACT 2005
RESOLUTION DECIDING TO AMEND A TOWN PLANNING SCHEME
SHIRE OF NORTHAM
LOCAL PLANNING SCHEME No. 6

RESOLVED THAT Council in pursuance of Section 75 of the Planning and Development Act 2005, amend the above Local Planning Scheme by:

1. Recoding Lot 100 (#54) Byfield Street, Northam to "Residential R20".
2. Amend the Scheme Map, accordingly.

Dated this 16th day of November 20²²...

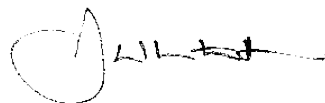

.....
CHIEF EXECUTIVE OFFICER

File No:.....
Part of Agenda:.....

MINISTER FOR PLANNING

PROPOSAL TO AMEND A SCHEME

1. *LOCAL AUTHORITY:* Shire of Northam

 2. *DESCRIPTION OF LOCAL PLANNING SCHEME:* Local Planning Scheme No. 6

 3. *TYPE OF SCHEME:* District Zoning Scheme

 4. *SERIAL No. OF AMENDMENT:* Amendment No. 18

 5. *PROPOSAL:* Recoding of Lot 100 (#54) Byfield Street, Northam from "Residential R15" to "Residential R20"
-

SCHEME AMENDMENT REPORT

Proposed Scheme Amendment No. 18

Recoding from "Residential R15" to "Residential R20"

Lot 100 (#54) Byfield Street, Northam

Shire of Northam Local Planning Scheme No. 6 (LPS6)

Proposed Scheme Amendment No. 18

Recoding from "Residential R15" to "Residential R20"

Part Lot 100 (#54) Byfield Street, Northam

Shire of Northam Local Planning Scheme No. 6 (LPS6)

Prepared by:

Akron Pty Ltd

61 Old York Road
NORTHAM WA 6401

T: 1300 125 766

E: kobus.nieuwoudt@akron.com.au

Prepared for:

Yilgarn Property Pty Ltd

Urban Planning Specialist:

Job Number:

Version / Date:

Kobus Nieuwoudt

TP005

Final Version / 14 October 2022

Contents

1.0	EXECUTIVE SUMMARY	1
2.0	INTRODUCTION	2
3.0	LOCATION & SITE DETAILS.....	3
4.0	SCHEME AMENDMENT PROPOSAL	5
4.1	<i>Amendment Specifications.....</i>	<i>5</i>
4.2	<i>Rationale in Support of Amendment</i>	<i>5</i>
4.3	<i>Concept Plan.....</i>	<i>5</i>
5.0	STRATEGIC & STATUTORY FRAMEWORK	6
5.1	<i>Local Planning Context.....</i>	<i>6</i>
5.1.1	<i>Local Planning Scheme No. 6</i>	<i>6</i>
5.1.2	<i>Shire of Northam Local Planning Strategy.....</i>	<i>7</i>
5.2	<i>State Planning Context</i>	<i>7</i>
5.2.1	<i>State Planning Policies.....</i>	<i>7</i>
5.2.2	<i>Development Control Policies.....</i>	<i>8</i>
5.3	<i>Other Planning Considerations</i>	<i>10</i>
5.3.1	<i>Utility Services.....</i>	<i>10</i>
5.3.2	<i>Roads</i>	<i>10</i>
6.0	CONCLUSION	11

Annexures

Annexure 1:	Certificate of Title
Annexure 2:	Concept Plan
Annexure 3:	Approved Plan of Subdivision Lots 100, 105 & 107
Annexure 4:	Approved Plan of Subdivision Lot 106 & Remnant Portion of Lot

PAGE LEFT BLANK INTENTIONALLY

1.0 EXECUTIVE SUMMARY

The purpose of this Scheme Amendment to the Shire of Northam Local Planning Scheme No. 6 (LPS6) is to recode Lot 100 (#54) Byfield Street in Northam (the subject land) from "Residential R15" to "Residential R20".

Akron, on behalf of the landowner (Yilgarn Property), seeks Council Approval to recode the subject land to facilitate the property being developed in conjunction with Lot 105 (1 Frankish Road), Lot 106 (3 Frankish Road) and Lot 107 (5 Frankish Road) in Northam, also owned by Yilgarn Property.

Akron's justification in support of the Scheme Amendment is summarised as follows:

- The proposal accords with the relevant State Planning and Development Control Policies of the Western Australian Planning Commission (WAPC);
- The subject land is contained in *Shire of Northam Local Planning Strategy 2013* as being suitable for increased residential development; and
- The subject land is located immediately adjacent to other Residential R20 coded land to the south, and opposite Residential R30 coded land to the west.

Akron therefore seeks the Council of the Shire of Northam's favourable consideration of the proposed Scheme Amendment.

For the purposes of the *Planning and Development (Local Planning Schemes) Regulations 2015*, the proposed Scheme Amendment is a 'Standard' Scheme Amendment as the proposal is consistent with a local planning strategy for the scheme that has been endorsed by the WAPC.

2.0 INTRODUCTION

Akron Pty Ltd acts for the landowner of Lot 100 (#54) Byfield Street, Northam and lodges this request on their behalf, seeking the Council of the Shire of Northam's support for a Scheme Amendment for the recoding of the site from "Residential R15" to "Residential R20".

The proposed Scheme Amendment seeks to increase residential development opportunities on the subject site in a manner similar to nearby and adjacent land in accordance with the current local town planning framework.

The Shire of Northam Administration's assessment on this proposal is sought and following a supportive report to the Council of the Shire of Northam for initiation, the formal Scheme Amendment documents and further information (if required) will be provided.

3.0 LOCATION & SITE DETAILS

The subject land is described on Certificate of Title Volume 1589, Folio 297. (Refer **Annexure 1 – Certificate of Title**).

The registered proprietor of the subject land is outlined in the table below:

Land Description	Registered Proprietor	Volume	Folio	Size
LOT 100 ON PLAN 13407	YILGARN PROPERTY PTY LTD OF PO BOX 910 NORTHAM	1589	297	8,838m ²

Lot 100 (#54 Byfield Street in Northam) is located on the corner of East Street and Byfield Street in Northam (refer **Figure 1 – Location Plan**).

Figure 1: Location Plan (Source: DPLH, PlanWA)



Lot 100 is currently zoned “Residential R15” by LPS6.

The subject site slopes down from south to north.

The land characteristics of the site include limited remnant vegetation and access to urban infrastructure services.

The subject land has been approved by the WAPC for subdivision with Lot 105, 106 and 107 Frankish Road. The approved plan of subdivision for Lot 100 currently

includes a proposed access road and yields 12 lots ranging from 581m² to 794m² in size.

The subject land has the following locational attributes:

- The land is located close to existing and developing urban areas of Northam and is adjacent to existing "Residential R20", "Residential R2.5" and "Residential R30" coded land;
- The land will have access to all urban infrastructure services;
- The land is approximately 4 minutes' drive from major shopping centre facilities in Northam CBD and less than a minute's drive from the nearest school;
- The land has no environmental issues which cannot be addressed, and which might otherwise, prevent further development; and
- The land is intended to be developed together with adjoining 'R20'-coded land (Lots 105, 106 and 107 Frankish Road).

4.0 SCHEME AMENDMENT PROPOSAL

4.1 Amendment Specifications

Proposed Scheme Amendment No. 18 to LPS6 seeks to recode Lot 100 on Plan 13407 (#54) Byfield Street, Northam from 'Residential R15' to "Residential R20".

4.2 Rationale in Support of Amendment

In circa 2017, the WAPC granted approval to subdivide Lot 100 (#54) Byfield Street, Lot 105 (#1) and Lot 107 (#5) Frankish Road as depicted on the attached Plan of Subdivision included at **Annexure 3 – Approved Plan of Subdivision Lots 100, 105 & 107**, as part of a single development. More recently, the WAPC also approved subdivision of Lot 106 (#3) Frankish Road and Part Lot 107 (#5) Frankish Road (refer **Annexure 4 – Approved Plan of Subdivision Lot 106 & Remnant Portion of Lot 107**, also forming part of the same subdivision.

The proposed recoding of Lot 100 will bring it into consistency with the current R20 density code of Lots 105, 106 and 107. At R20 density code, Lot 100 could potentially yield up to 16 lots ranging between 413m² to 610m², including a public access road.

The proposed recoding of Lot 100 will further increase residential development capacity and reduce the need for the long-term provision of new 'Residential' zoned land. This principle is supported by the Shire of Northam's Local Planning Strategy.

Further rationale in support of the proposed Scheme Amendment is outlined in response to the various Planning requirements associated with the site, outlined and detailed in Section 5.0 of the Scheme Amendment Report.

4.3 Concept Plan

The proposed Scheme Amendment will enable a resultant subdivision/development which is depicted in the attached Concept Plan included at **Annexure 2**.

The Concept Plan identifies a layout for the lot, which will be developed in stages at R20 density code in conjunction with Lot 105 to the south, including Lot 106 and Lot 107 to the south-east.

5.0 STRATEGIC & STATUTORY FRAMEWORK

5.1 Local Planning Context

5.1.1 Local Planning Scheme No. 6

The subject land is zoned "Residential R15" by Shire of Northam Local Planning Scheme No. 6 (LPS6).

Clause 4.2 of LPS6 will apply to the recoded land, as it deals with the Residential Design Codes (R Codes). In accordance with subclause 4.2.2, the development of land in LPS6 for any of the residential purposes dealt with by the R Codes (unless otherwise provided for in LPS6), is to conform with the provisions of those Codes.

The land is not affected by any of the Special Control Areas contained in Part 5 of LPS6.

The site is located directly adjacent to land that is coded R20 to the south, land coded R2.5 to the east, and land coded R30 west of East Street. Refer LPS6 Zoning Map Extract at **Figure 2** below.

Figure 2: LPS6 Zoning Map Extract



The objectives of the Residential Zone (subclause 3.2.1 of LPS6) are to –

- *Provide for residential development at a range of densities with a variety of housing types to meet the needs of all sectors of the community through application of the Residential Design Codes.*
- *Maintain and enhance the residential character and amenity of the zone.*

5.1.2 Shire of Northam Local Planning Strategy 2013

The Shire of Northam Local Planning Strategy 2013 depicts the subject land as existing urban land in Northam Townsite.

The Vision/Objective for Housing under the LPS (cl. 2.2.3) is, *“to ensure a sufficient supply of suitably zoned and serviced residential land in established settlements to accommodate future housing growth and to provide for housing choice and variety in neighbourhoods with a community identity and high levels of affordability, accessibility, safety, sustainability and visual amenity.”*

With respect to Northam Townsite, the LPS also highlights the potential for increases in density of low-density residential areas, which will further increase residential development capacity and reduce the need for the long-term provision of new ‘Residential’ zoned land.

The proposed Scheme Amendment is also consistent with the set Strategies for Housing in the LPS given the proposed Scheme Amendment –

- encourages the take up of existing residential land in the Northam Townsite prior to proceeding with new land releases;
- directs new housing development to the Northam Townsite;
- will provide for development which take advantage of existing services in the immediate area; and
- will provide for additional housing types in a central location.

5.2 State Planning Context

5.2.1 State Planning Policies

State Planning Policy 7.3 – Residential Design Codes Volume 1

The purpose of the R-Codes is to provide a comprehensive basis for the control of residential development throughout Western Australia.

The general objectives of the R-Codes Volume 1 are to –

- provide residential development of an appropriate design for the intended residential purpose, density, context of place and scheme objectives;
- encourage design consideration of the social, environmental and economic opportunities possible from new housing and an appropriate response to local amenity and place;
- encourage design which considers and respects heritage and local culture; and
- to facilitate residential development which offers future residents the opportunities for better living choices and affordability.

The proposed Scheme Amendment accords with the general objectives of the R-Codes Volume 1.

5.2.2 Development Control Policies

Development Control Policy 2.2– Residential Subdivision (DCP 2.2)

The objectives of DCP 2.2 are to –

- establish a consistent and coordinated approach to the creation of residential lots throughout Western Australia;
- adopt criteria for residential lots which will ensure that each lot has a suitable level of amenity, services and access; and
- to facilitate the supply of residential lots in regular shapes and size ranges that reflect the statutory provisions of local planning schemes – including the R-Codes, the availability of reticulated sewerage, electricity and water and the need for frontage to public streets for access.

The proposed Scheme Amendment accords with the abovementioned objectives.

The 'General Requirements' of the 'Policy Measures' at subclause 4.1.1 of DCP 2.2 indicate that applications for the subdivision of land into residential lots will be assessed against –

- criteria set out in clause 4.1.3 of DCP 2.2;

- the context of the general subdivision requirements of DCP 1.1 – *Subdivision of Land – General Principles*;
- state and local planning frameworks, including Liveable Neighbourhoods; and
- water sensitive urban design principles.

In response to these general requirements, the following is provided with respect to Lot 100 –

- all new development sites or lots created on the land will be capable of development in accordance with the R-Codes, read with subclause 4.3.2 in LPS6;
- any new proposed lots and any new development to be created on the land will take into account the topography of the site and include appropriate stormwater drainage systems as required;
- any new proposed lots and any new development to be created on the land will link with the existing pedestrian footpath network; and
- the development is located close to Northam CBD, an existing school and public open space.

The proposed recoding of the subject land from R15 density code to R20 density code, therefore, accords with the General Requirements outlined under subclause 4.1.1 of DCP 2.2.

5.3 Other Planning Considerations

5.3.1 Utility Services

The subject land will be provided with telecommunications, a reticulated power supply, scheme water and sewer services.

5.3.2 Roads

The site has frontage to East Street to the west, and Byfield Street to the north. These roads are under the maintenance, care, and control of the Shire of Northam.

6.0 CONCLUSION

Given the proposed Scheme Amendment is consistent with the objectives of *Shire of Northam Local Planning Strategy 2013* and accords with the Western Australian Planning Commission's relevant State Planning and Development Control Policies, it is requested that the Council of the Shire of Northam initiates proposed Scheme Amendment No. 18 to Shire of Northam Local Planning Scheme No. 6 to recode Lot 100 (#54) Byfield Street, Northam from "Residential R15" to "Residential R20".

ANNEXURES

ANNEXURE 1

Certificate of Title

WESTERN



AUSTRALIA

REGISTER NUMBER 100/P13407	
DUPLICATE EDITION 4	DATE DUPLICATE ISSUED 17/12/2015

RECORD OF CERTIFICATE OF TITLE
UNDER THE TRANSFER OF LAND ACT 1893

VOLUME **1589** FOLIO **297**

The person described in the first schedule is the registered proprietor of an estate in fee simple in the land described below subject to the reservations, conditions and depth limit contained in the original grant (if a grant issued) and to the limitations, interests, encumbrances and notifications shown in the second schedule.

BGRoberts
REGISTRAR OF TITLES



LAND DESCRIPTION:

LOT 100 ON PLAN 13407

REGISTERED PROPRIETOR:
(FIRST SCHEDULE)

YILGARN PROPERTY PTY LTD OF PO BOX 910 NORTHAM

(T N202930) REGISTERED 15/12/2015

LIMITATIONS, INTERESTS, ENCUMBRANCES AND NOTIFICATIONS:
(SECOND SCHEDULE)

Warning: A current search of the sketch of the land should be obtained where detail of position, dimensions or area of the lot is required.
* Any entries preceded by an asterisk may not appear on the current edition of the duplicate certificate of title.
Lot as described in the land description may be a lot or location.

-----END OF CERTIFICATE OF TITLE-----

STATEMENTS:

The statements set out below are not intended to be nor should they be relied on as substitutes for inspection of the land and the relevant documents or for local government, legal, surveying or other professional advice.

SKETCH OF LAND: 1589-297 (100/P13407)
PREVIOUS TITLE: 1589-296
PROPERTY STREET ADDRESS: 54 BYFIELD ST, NORTHAM.
LOCAL GOVERNMENT AUTHORITY: SHIRE OF NORTHAM

ANNEXURE 2

Concept Plan



ANNEXURE 3
Approved Plan of Subdivision Lots 100,
105 & 107

Attachment 3 - Attached plan

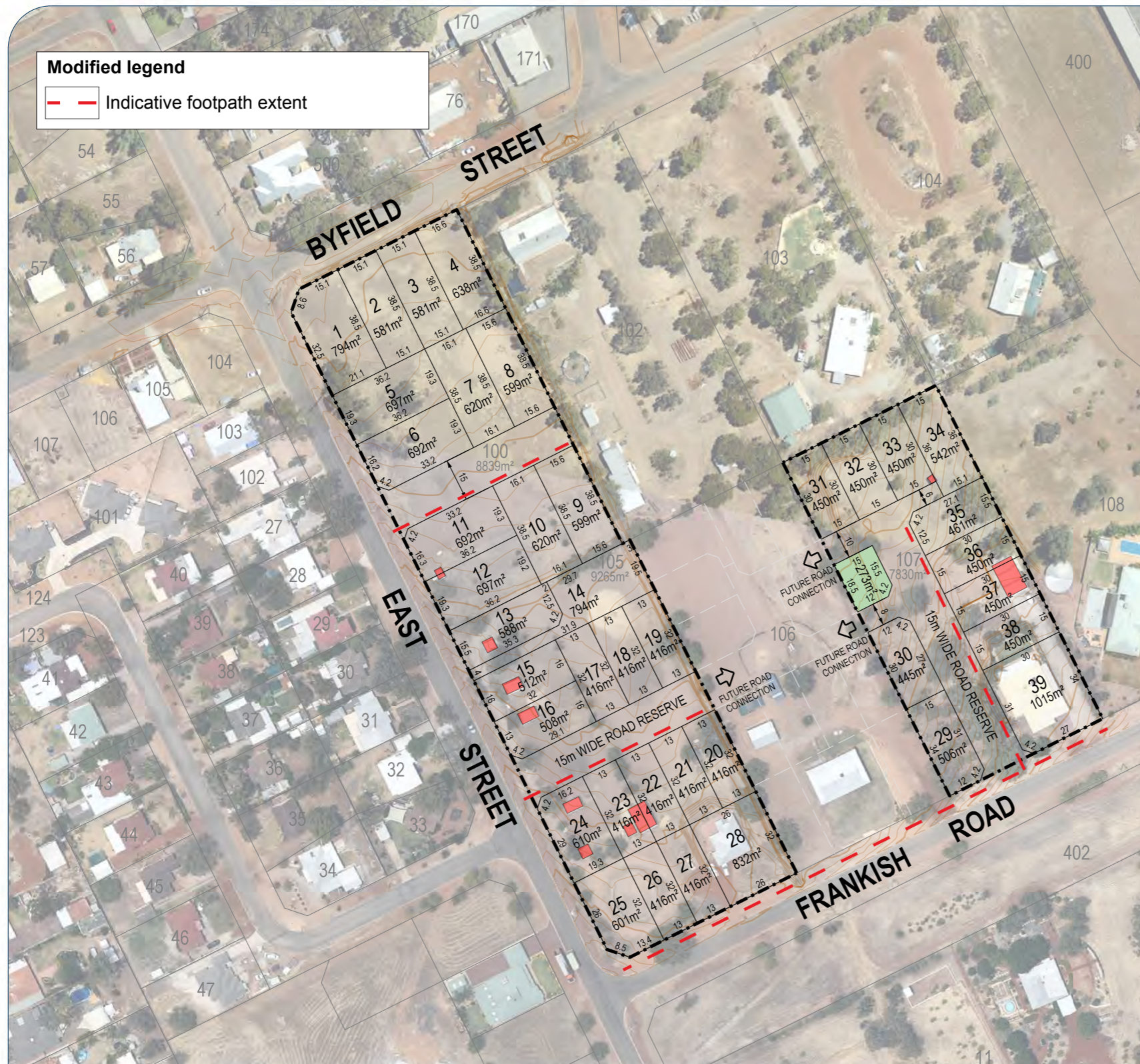

Modified legend
— — Indicative footpath extent

LEGEND

- EXISTING CADASTRE
- EXISTING MAJOR CONTOURS - 1m INTERVALS
- EXISTING MINOR CONTOURS - 0.2m INTERVALS
- ▭ SUBJECT LAND
- PROPOSED CADASTRE
- ▭ PUBLIC OPEN SPACE
- CONCEPTUAL FUTURE CADASTRE
- ▭ BUILDINGS TO BE DEMOLISHED

LOT YIELD TABLE

Size	LOT YIELD		LOT AREA		
	No. Lots	% Total Lots	Average Size	% of Total Area	Area
320m ² - 449m ²	10	25.64%	418m ²	19.33%	4189m ²
450m ² - 499m ²	7	17.95%	451m ²	14.59%	3161m ²
500m ² - 549m ²	4	10.26%	517m ²	9.54%	2068m ²
550m ² - 599m ²	3	7.69%	583m ²	8.08%	1750m ²
600m ² - 699m ²	11	28.21%	642m ²	32.61%	7065m ²
700m ² - 799m ²	2	5.13%	794m ²	7.33%	1588m ²
800m ² - 899m ²	1	2.56%	832m ²	3.84%	832m ²
1000m ² - 1499m ²	1	2.56%	1015m ²	4.68%	1015m ²
Total Number of Lots	39				

Minimum Lot Size 416m²
Maximum Lot Size 1015m²

Average Lot Size 555m²
Total Lot Area 21668m²

**DEPARTMENT OF PLANNING, LANDS
AND HERITAGE**

DATE	FILE
15-Nov-2017	155540

calibre
CONSULTING
 Calibre Consulting (Aust) Pty Ltd
 Unit 5, 53 Victoria Street
 Bunbury WA 6230
 Ph 08 9791 4411
 www.calibreconsulting.co
Copyright: This document is and shall remain the property of Calibre Consulting (Aust) Pty Ltd.

SUBDIVISION PLAN
 Lots 100, 105 and 107 East Street, Northam

Plan No: 17-001244P-SU-01C
 Date: 15.11.2017
 Rev: C
 Scale: A1 @1:750, A3 @ 1:1500
 Co-ords: Local Grid
 Aerial: Nearmap

This plan has been prepared for planning purposes. Areas, contours and dimensions shown are subject to survey.

ANNEXURE 4
***Approved Plan of Subdivision Lot 106 &
Remnant Portion of Lot 107***

DEPARTMENT OF PLANNING, LANDS AND HERITAGE	
DATE	FILE
30-May-2022	162419

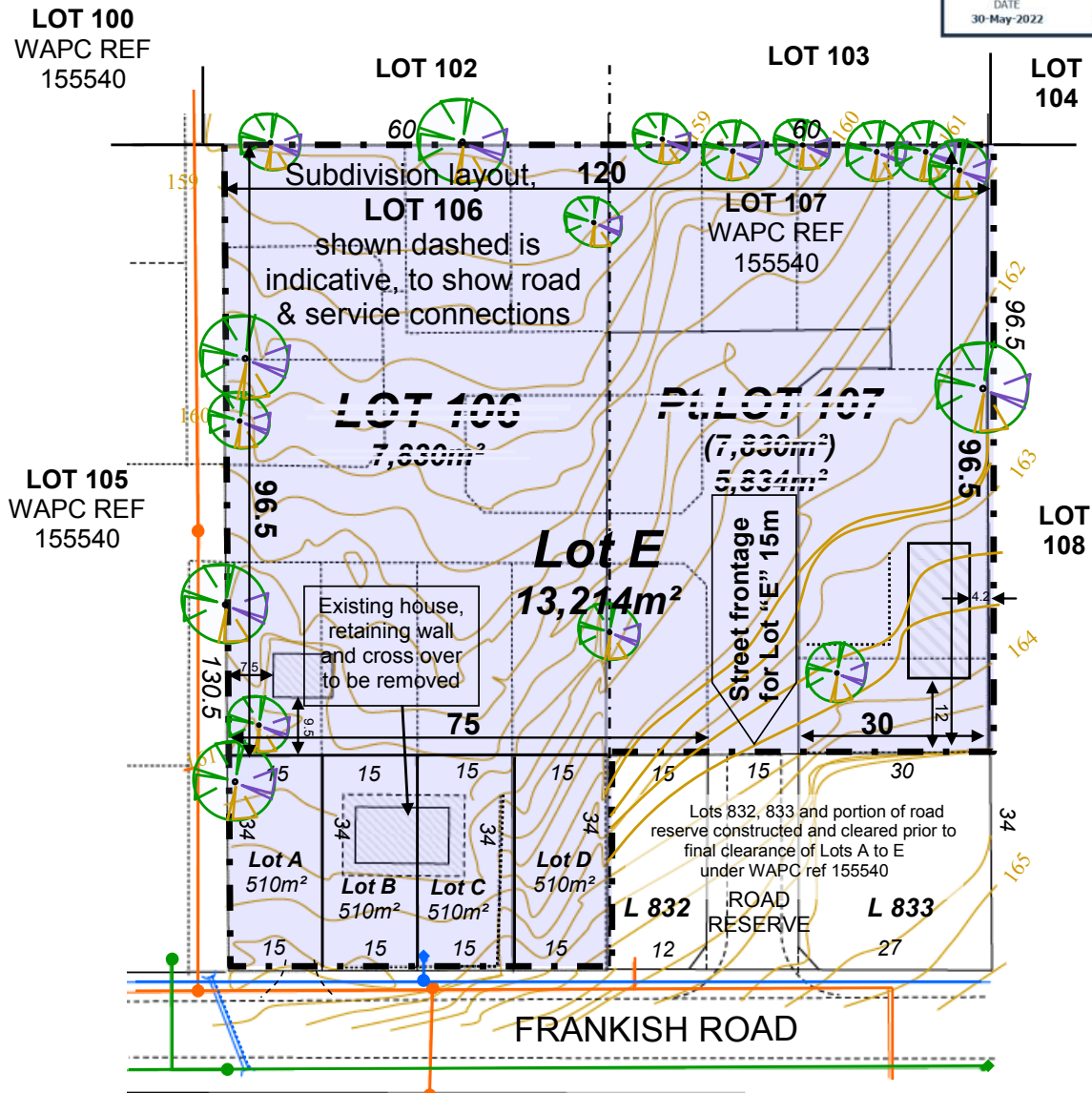

LEGEND

- Sewer
- Water
- Electricity
- Drainage
- Retaining wall
- Contours
- Existing Structures
- Trees

Portion of Lot 107, showing Lots 832, 833 and Road reserve is subject of lodgement of plan of survey for first stage of subdivision WAPC ref 155540, due for clearance in September 2022.
Parent Lots
Lot 106 on PLAN 13407 C/T 1589-387
Lot 107 on PLAN 13407 C/T 1589-388

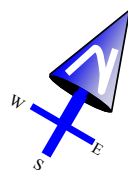

SCALE 1:1000 @ A4

PROJECT NAME & CLIENT		Subdivision of Lot 106 and amalgamation of remnant portion with Pt 107 Frankish Rd for YILGARN			
ADDRESS		Lots 106 & 107 (#3&5) Frankish Rd NORTHAM			
JOB REF	238 FN	SK #	SUB stg 2.1	DRWN	dst
PO BOX 890 Fremantle 6959 david@networkppd.com.au +61 417 943 744					

SCHEME AMENDMENT MAPS

SHIRE OF NORTHAM LOCAL PLANNING SCHEME NO. 6
PROPOSED SCHEME AMENDMENT NO. 18

SCHEME MAP

EXISTING ZONING

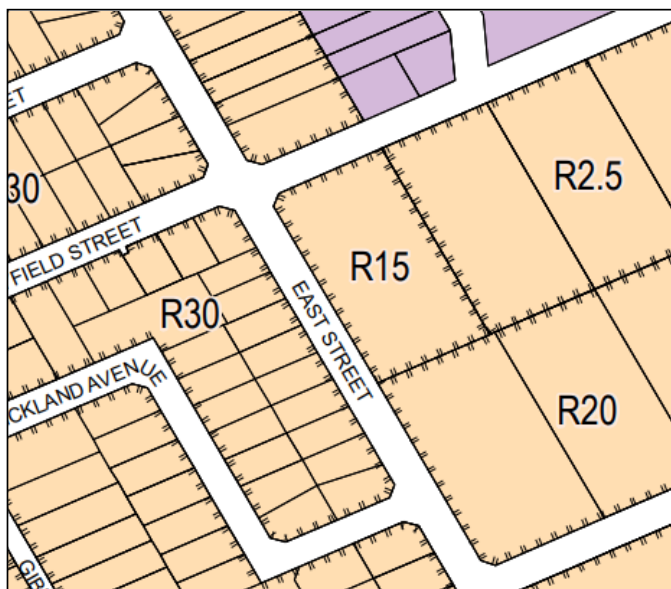

LOCAL SCHEME ZONES

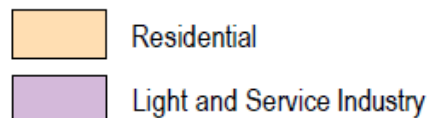

PROPOSED ZONING



SCHEME AMENDMENT DOCUMENTS

PLANNING AND DEVELOPMENT ACT 2005
SHIRE OF NORTHAM
LOCAL PLANNING SCHEME No. 6
AMENDMENT No. 18

The Council of the Shire of Northam under and by virtue of the powers conferred upon it in that behalf by the Planning and Development Act 2005, hereby amends the above Local Planning Scheme by:

1. Recoding Lot 100 (#54) Byfield Street, Northam to "Residential R20".
2. Amend the Scheme Map, accordingly.

ADOPTION

Adopted by resolution of the Council of the Shire of Northam at the Meeting of the Council held on the day of 20.....

.....
SHIRE PRESIDENT

.....
CHIEF EXECUTIVE OFFICER

FINAL APPROVAL

ADOPTED for Final Approval by resolution of the Shire of Northam at the Meeting of the Council held on the day of 20..... and the Common Seal of the Shire of Northam was hereunto affixed by the authority of a resolution of the Council in the presence of:

.....
SHIRE PRESIDENT

.....
CHIEF EXECUTIVE OFFICER

Recommended/Submitted for Final Approval

.....
**DELEGATED UNDER S.16 OF
THE PD ACT 2005**

Date

Final Approval granted

.....
MINISTER FOR PLANNING

Date





Environmental Protection Authority

Mr Jason Whiteaker
Chief Executive Officer
Shire of Northam
PO Box 613
NORTHAM WA 6401

Our Ref: APP-0000160
Enquiries: Liz Stewart, 6364 6468
Email: Liz.Stewart@dwer.wa.gov.au

Dear Mr Whiteaker

DECISION UNDER SECTION 48A(1)(a)
Environmental Protection Act 1986

SCHEME	Shire of Northam Local Planning Scheme 6 Amendment 18
LOCATION	Lot 100 (No. 54) Byfield Street, Northam
RESPONSIBLE AUTHORITY	Shire of Northam
DECISION	Referral Examined, Preliminary Investigations and Inquiries Conducted. Scheme Amendment Not to be Assessed Under Part IV of the EP Act. No Advice Given. (Not Appealable)

Thank you for referring the above scheme to the Environmental Protection Authority (EPA).

After consideration of the information provided by you, the EPA considers that the proposed scheme should not be assessed under Part IV Division 3 of the *Environmental Protection Act 1986* (EP Act) and that it is not necessary to provide any advice or recommendations. I have attached a copy of the Chair's determination of the scheme.

Please note the following:

- For the purposes of Part IV of the EP Act, the scheme is defined as an assessed scheme. In relation to the implementation of the scheme, please note the requirements of Part IV Division 4 of the EP Act.
- There is no appeal right in respect of the EPA's decision to not assess the scheme.

Prime House, 8 Davidson Terrace Joondalup, Western Australia 6027.
Postal Address: Locked Bag 10, Joondalup DC, Western Australia 6919.

Telephone: (08) 6364 7000 | Facsimile: (08) 6364 7001 | Email: info.epa@dwer.wa.gov.au

A copy of the Chair's determination will be made available to the public via the EPA website.

Yours sincerely

A handwritten signature in blue ink, appearing to read 'MAT TONTS', with a stylized flourish extending to the right.

Prof. Matthew Tonts
Chair of the Environmental Protection Authority

13 December 2022

Encl. Chair's Determination

SCHEDULE OF SUBMISSIONS

SCHEME AMENDMENT 18 – LOT 100 (54) BYFIELD STREET, NORTHAM

No.	Submitter	Summary of Submission (full copies attached)	Applicant's Response	Officer's Comment
1.	Department of Education	The Department has no in principle objections to the proposed amendment.	Noted.	Noted.
2.	Department Water & Environmental Regulation	The Department of Water and Environmental Regulation has assessed the above referral and has no comments to provide.	Noted.	Noted.
3.	Western Power	Unfortunately requests for general comments, feedback and approval for proposals can't be provided for without application and the investigation and dialogue that allows.	Noted.	Noted. Refer to Western Power Clearance Zone map (attached to this Schedule), which indicates that there are no impacts.
4.	Department of Mines, Industry Regulation & Safety	The Department of Mines, Industry Regulation and Safety (DMIRS) has determined that this proposal raises no significant issues with respect to mineral and petroleum resources, geothermal energy, and basic raw materials.	Noted.	Noted.
5.	Telstra	Please be advised that Telstra has no objections to the Proposed Standard Scheme Amendment No. 18. Please note that another telecommunications carrier has assets within the area of concern.	Noted.	Noted. Dial Before You Dig enquiry lodged and indicates that the NBN has infrastructure (plan attached to this Schedule) along the Byfield Street frontage that may affect works in that area.
6.	Neighbouring landowners	<p>Objects to proposal due to proposal resulting in an increase of lots within development area.</p> <p>Objects to increase in hard surfaces.</p> <p>Application fails to address or contemplate requirement to retain and manage water runoff; need to construct suitable drains and pollution traps; and natural hydrological regime.</p> <p>Concerns are heightened because of careless and unstructured approach taken with works completed to date, including ongoing degradation of boundary with Lot 100; failure to remediate disturbance of current underground services; high level of risk created by failing to replace boundary fence after works; and refusal to follow due process when dealing with neighbours.</p> <p>Specific objections relate to impact on Jones Brook drainage system; lack of easement over Lot 102; Jones Brook is on private property; and proposed open drain on boundary of Lots 100 and 102 encroaching 3m inside Lot 102.</p> <p>Concerns about the impacts of the development on Lots 102 and 103.</p>	<p>We note the objectors' concerns regarding the effect of stormwater runoff (emanating from Jones Brook) on their property. However, it is, in our opinion, not a relevant consideration in the context of the Scheme Amendment proposal.</p> <p>Stormwater drainage for new subdivisions is generally considered and addressed at the subdivision stage (including at the subdivision clearance stage) where engineering drawings and specifications are to be submitted and approved, and the works executed in accordance with the approved engineering drawings and specifications.</p>	<p>Whilst the Officer considers the concerns regarding drainage issues are valid, as indicated by the Applicant, drainage is an issue that is assessed during the subdivision application stage, and any consequent development and building applications.</p> <p>Officers are confident that the drainage issues can be addressed through the preparation, assessment, and approval of detailed drainage plans, which will need to be based on the standard practice of requiring the post-development flows to meet pre-development flows.</p> <p>Any easements can also be required at this stage of the development.</p> <p>The other issues, such as fencing and neighbour liaison, raised in the submission are private issues that need to be resolved between the two parties.</p>
7.	Water Corporation	Thank you for your correspondence of 3 January 2023 inviting comments on the above rezoning. The Water Corporation has no objections to the proposal.	Noted.	Noted.

13.3.2 Proposed Incidental Use - 366 Horton Road, Woottating

Address:	Lot M1822 (No. 366) Horton Road, Woottating
Owner:	Gravel Pty Ltd
Applicant:	Owner
File Reference:	P23000 / A1271
Reporting Officer:	Jacky Jurmann (Acting Executive Manager Development Services)
Responsible Officer:	Jacky Jurmann (Acting Executive Manager Development Services)
Officer Declaration of Interest:	Nil
Voting Requirement:	Simple Majority
Press release to be issued:	No

BRIEF

An application has been received to obtain development to carry out block making activities incidental to the approved use of the site as an extractive industry.

In accordance with the Shire's Delegated Authority (P03), the application is being presented to Council for determination.

ATTACHMENTS

1. Application Documents [**13.3.2.1** - 83 pages]
2. Location Plan [**13.3.2.2** - 1 page]
3. Extractive Industry Plan [**13.3.2.3** - 1 page]
4. Statutory Assessment [**13.3.2.4** - 3 pages]

A. BACKGROUND / DETAILS

Location

The site is located on M1822 (No. 366) Horton Road, Woottating and has an area of 40.5748 hectares. Refer to the Location Plan attached to this Report (Attachment 2).

Stage 1 of the extractive industry is located on the front western portion of the lot with Stage 2 occupying the remainder of the property except for the environmentally sensitive areas.

The property is zoned Rural and is located on the western boundary of the Northam local government area adjacent to the Purearth Composting Facility and the BGC Voyager II Quarry.

Previous Approvals

20/12/2012 – Condition development approval (ref: P1608) was granted for an extractive industry for the extraction area identified as Stage 1. Refer to the Extractive Industry Plan attached to this Report (Attachment 3).

19/08/2020 – DWER granted a Licence to permit screening of gravel associated with the approved extractive industry. The threshold of the Licence is 55,000 tonnes per year.

20/08/2022 – Council conditionally approved Stage 2 of the extractive industry (Minute No: C.4440). Refer to the Extractive Industry Plan attached to this Report (Attachment 2).

Proposal

To develop an incidental block making operation from the gravel extracted on site to supply to wholesale markets, such as landscaping supplies and local trades for building retaining walls, etc.

It is intended that the sale of the blocks will replace the majority of extracted and screened bulk gravel sales from the site's extraction activities with a proposed product split of 98% block products and 2% bulk gravel product. Noting that no retail sales from the site are proposed.

Details of the block making machine are provided in the Operational Environmental Management Plan on page 23. The typical block and size to be produced will be 1000 x 350 x 350mm and the production rate will average about 2500 blocks produced per week allowing time for curing and space for product storage.

The block making activities will be incidental to the approved extractive industry operations conducted under the existing development approvals and licences.

B. CONSIDERATIONS

B.1 Strategic Community / Corporate Business Plan

Performance Area: Performance.

Outcome 13: A well informed and engaged community.

Objective 13.1: Provide strong, open and accountable leadership and be more visible and relevant for community members.

Priority Action: Nil.

B.2 Financial / Resource Implications

There are no financial implications associated with the proposal. The relevant application fee has been paid by the Applicant.

B.3 Legislative Compliance

The application has been assessed in accordance with the provisions of the Planning and Development Act 2005, Regulations and Northam Local Planning Scheme No. 6. Refer to the Statutory Assessment attached to this Report (Attachment 4).

B.4 Policy Implications

There are no policy implications associated with this Report.

B.5 Stakeholder Engagement / Consultation

Incidental uses do not require advertising under the provisions of the Planning and Development (Local Planning Schemes) Regulations 2015 and Local Planning Policy No 20 – Advertising of Planning Proposals.

B.6 Risk Implications

Risk Category	Description	Rating (likelihood x consequence)	Mitigation Action
Financial	N/a	N/a	N/a
Health & Safety	N/a	N/a	N/a
Reputation	N/a	N/a	N/a
Service Interruption	N/a	N/a	N/a
Compliance	Non-compliance with any conditions of approval.	Medium (3) x Possible (3) = Moderate (9)	Continuous monitoring of conditions to ensure compliance.
Property	N/a	N/a	N/a
Environment	N/a	N/a	N/a

B.7 Natural Environment Considerations

There are no additional natural environment considerations applicable to this proposal that have not been considered in the Statutory Assessment.

C. OFFICER'S COMMENT

The main issues associated with the proposal as identified in the Statutory Assessment relate to potential noise, dust and traffic generation.

Information has been provided in the Applicant's OEMP (Attachment 1) that provides an assessment of these issues and the proposed mitigation measures,

which together with conditions of approval are adequate to manage any potential impacts.

RECOMMENDATION / COUNCIL DECISION

Minute No: C.4693

Moved: Cr M P Ryan

Seconded: Cr A J Mencshelyi

That Council:

Approve the development application (ref: P23000) to conduct an incidental use (block making) to the approval Industry – Extractive at Lot M1822 (No. 366) Horton Road, Woottating, subject to the following conditions:

- 1. The development hereby approved must substantially commence within two (2) years from the date of determination.**
- 2. All development must be carried out in accordance with the approved plans [and drawings] as listed below:
 - a. Site Plan (No. A1.01) dated 10/01/2023;**
 - b. Operational Environmental Management Plan dated 21/12/2022; and**
 - c. Works Plan dated 13/01/2023.****

In the event of an inconsistency between the approved plans and a requirement of the conditions set out below, the requirement of the conditions shall prevail.

- 3. The block making shall be incidental to the predominant use of the site as an extractive industry. No retail sales are permitted.**
- 4. This approval does not amend the previous development approval (ref: P21082 issued on 28/04/2022). The conditions remain valid and continue to have effect unless there is an inconsistency, the conditions of this approval shall prevail.**
- 5. Hours of operation of the block making activities are limited to Monday to Friday 7:00 am to 6:00 pm and Saturdays 7:00 am to 12 noon. No works are permitted outside these hours or on public holidays without the prior approval of the local government.**
- 6. At all times during carrying out of the development all works and construction activities must be undertaken so as to avoid noise, vibration and dust nuisance to occupiers of land in the vicinity to the satisfaction of the local government.**
- 7. Vehicular access to and from the extractive industry hereby permitted shall be via the Great Eastern Highway only. There is to be no direct vehicular access from the Great Southern Highway to the extractive industry hereby permitted.**
- 8. All car parking/loading areas, and vehicle access and circulation areas are to be maintained and available for car parking/loading,**

and vehicle access and circulation on an ongoing basis to the satisfaction of the local government.

9. The applicant must implement the recommendations contained in the Bushfire Management Plan prepared by Bushfire Protection Australia dated 09/07/2020 and approved by the local government for the duration of the development.
10. Prior to occupation or use of the development, the approved stormwater management measures shall be implemented and thereafter maintained to the satisfaction of the local government.
11. Should any complaints be received (e.g., noise or vibration), the Applicant shall employ suitably qualified personnel to prepare an assessment to recommend mitigation strategies, which shall be submitted to the local government for approval prior to implementation.
12. Existing trees shall be retained unless specifically identified for removal on the approved plans.
13. All wastes shall be stored within a designated bin enclosure and shall be collected from the site by a private contractor at the cost of the owner/ occupier.

CARRIED 8/0



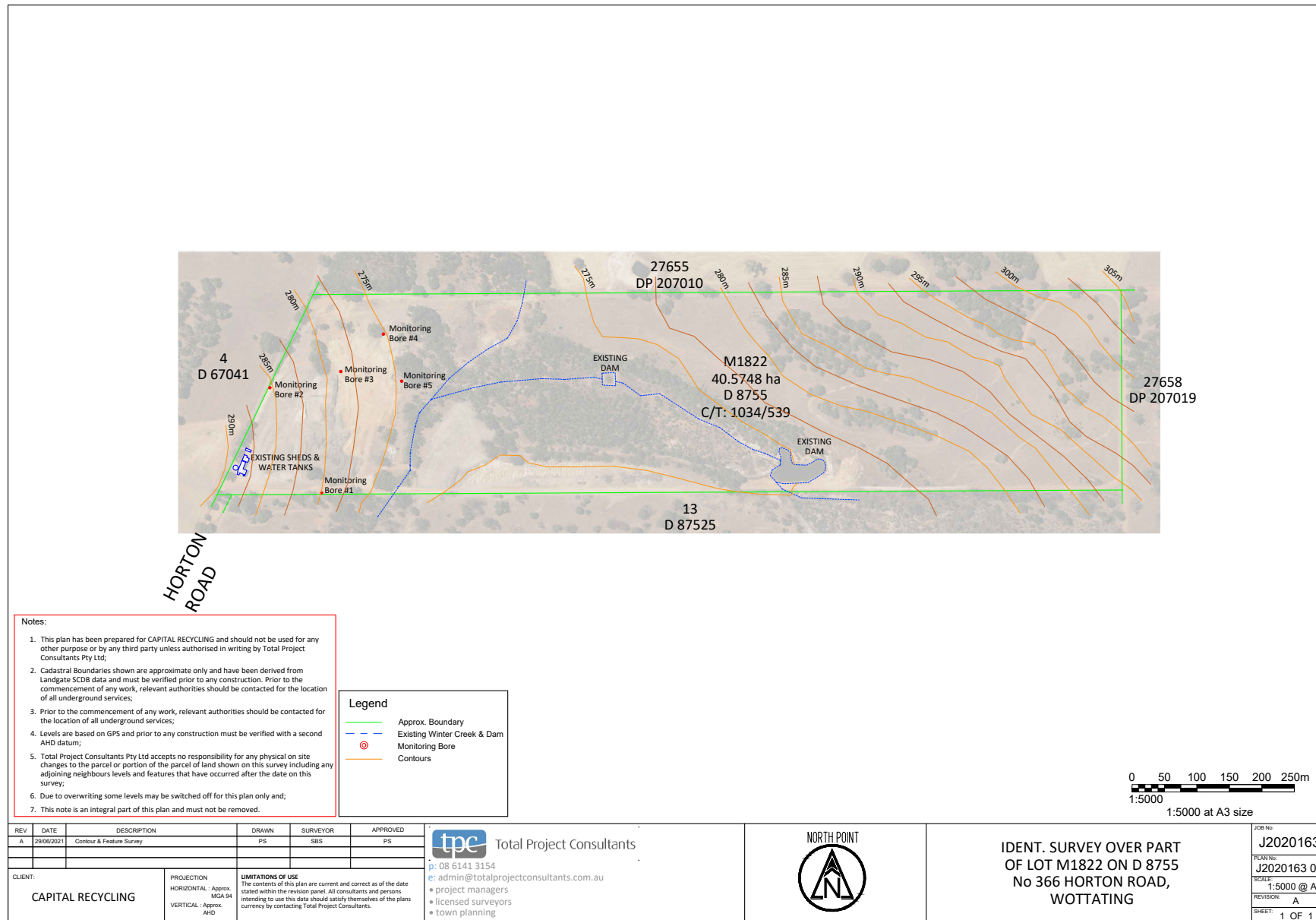



- Notes:**
1. This plan has been prepared for CAPITAL RECYCLING and should not be used for any other purpose or by any third party unless authorised in writing by Total Project Consultants Pty Ltd.
 2. Cadastral Boundaries shown are approximate only and have been derived from Landgate SCDB data and must be verified prior to any construction. Prior to the commencement of any work, relevant authorities should be contacted for the location of all underground services.
 3. Prior to the commencement of any work, relevant authorities should be contacted for the location of all underground services.
 4. Levels are based on GPS and prior to any construction must be verified with a second AHJD datum.
 5. Total Project Consultants Pty Ltd accepts no responsibility for any physical on site changes to the parcel or portion of the parcel of land shown on this survey including any adjoining neighbours levels and features that have occurred after the date on this survey.
 6. Due to overwriting some levels may be switched off for this plan only and;
 7. This note is an integral part of this plan and must not be removed.

NOTE: EXISTING BOUNDARY DIMENSIONS AND LOT AREAS TAKEN FROM LANDGATE RECORD D 8755

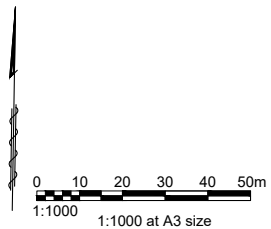

REV	DATE	DESCRIPTION	DRAWN	SURVEYOR	APPROVED
A	15/12/2022	Contour & Feature Survey	PS	SBS	SBS

CLIENT:	PROJECTION	LIMITATIONS OF USE The contents of this plan are current and correct as of the date stated within the revision panel. All consultants and persons intending to use this data should satisfy themselves of the plans currency by contacting Total Project Consultants.
	HORIZONTAL: Approx. MGA 94 VERTICAL: Approx. AHJD	

Total Project Consultants p: 08 6141 3154 e: admin@totalprojectconsultants.com.au • project managers • licensed surveyors • town planning	CONTOUR & FEATURE SURVEY OVER PART OF LOT M1822 ON D 8755 No 366 HORTON ROAD, WOOTTATING	JOB No: J2020163 PLAN No: J2020163 11 SCALE: 1:1000 @ A3 REVISION: A SHEET: 1 OF 1
--	---	--

F44 | Block Making Machine | Coote Finlay

The Finlay F44 is the most dynamic, fully automated machine anywhere in the world.

[Download Brochure](#)

The Finlay F44 range of Mobile Block Machines are Iconic, apart from being the worlds most versatile mobile block machine, they are highly sought after and instantly recognisable. The F44 range has undergone a complete overhaul, with a more refined and modern appearance coupled with new levels of power and economy which is setting the standards for performance. The F44 is always original with its distinctive profile but now features advanced technology with cutting edge developments borne from decades of experience with unbeatable pedigree. This new generation of the F44 mobile block making machine is here with a completely updated electrical control system that is designed to provide minimal downtime with maximum production. The King of mobile block making machinery is becoming a Legend.

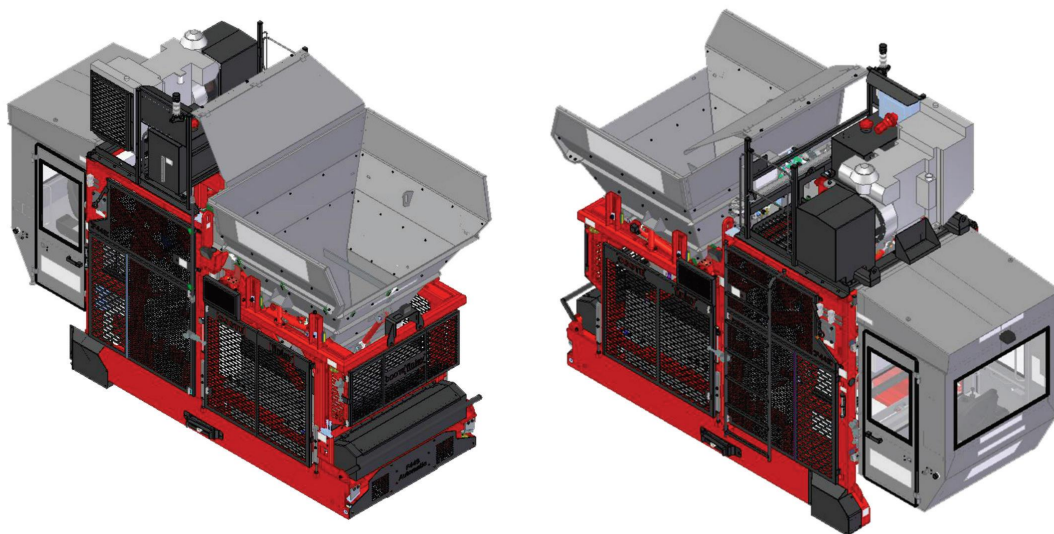

F44 Specification

<https://cootefinlay.com/products/block-making-equipment/f44-block-making-machine/>

1/3

F44 | Block Making Machine | Coote Finlay

Controls	Fully Automatic (Pre-programmed)	
Engine	Emissions compliant engine complete with "deep sea" engine/generator management system	
Touchscreen PLC controls system	Included	
In Row steering	Automatic	
Hard-wired remote control unit	Included	
Tamper head quick release system	Included	
Unique easy-fit mould box	Included	
Maximum mould area	1160mm x 916mm	
Cycle time	25 – 30 seconds depending on application	
http	190mm – 450mm	achine/

F44 | Block Making Machine | Cooto Finlay

Product height range

Safety guards all round with captive key locking system

Included

Hopper capacity

2.5m³ max

Mould Vibrators

Included



<https://cootefinlay.com/products/block-making-equipment/f44-block-making-machine/>

3/3

Sami T2, T3 and T4 - Batchcrete International

Applications

- The Sami range of mobile batch plants are designed for storage and controlled extraction of aggregates.
- The Sami mobile batching plant has a small footprint and is ideal for the batching of materials for concrete production, batching of road base materials or for the controlled dispatch of mining waste used as paste fill.
- With capabilities of lifting aggregates up to 3.4 metres, the Sami is ideal for loading agitator trucks.

Capabilities

- The Sami range are notable for their small dimensions and changeable geometric configuration which emphasize the benefits of compactness, allowing transportation of the machine by standard trailers.
- Four hydraulic legs can be fitted as an accessory, enabling the machine to be loaded and unloaded when empty without the need for crane. During transport the legs retract into the frame of the machine. During the positioning phase they open out allowing the vehicle to drive away or move back under the machine.
- The load cells and digital display instruments control the quantity of materials stored and extracted.
- The automatic display shows the net weight of materials in the bins and the extraction of products are automatic. At the same time on-board systems provide constant tallies of remaining materials on board.
- Sami's digital instruments can memorise up to 99 dosage formulas for the products in the bins. These formulas can also be modified with ease.

Features and benefits

- The Sami Batching system consists of 2, 3 or 4 bin options, each with a capacity of 4.5m³.
- The machine features a conveyor belt specially shaped for lifting aggregates up to heights of about 3.4m.
- The conveyor belt features sides and cleats which provide horizontal transportation along the first section and a 65 degree incline along the second section. The two belts are connected to make the machine more compact and easier to transport.
- Using a hydraulic system, the conveyor belt can be adjusted closer to the bins in order to reduce space whilst in storage or transport mode.
- 2 -4 hopper configuration dependent on model
- Total storage between 16m³ to 32m³ dependent on model
- Theoretical production 45m³ per hour.
- Plant weight between 5500kg to 7500kg dependant on mode
- Installed power 10kW to 16kW dependant on model
- Power absorption 5.5kW
- Three phase voltage 380 V, 50Hz



<https://batchcrete.net.au/product/sami-t2-t3-and-t4/>

1/1

Summary Development Approval Application 366 Horton Road, Woottating

Gravel Pit Pty Ltd

18 January 2023



Issue V0

Summary

January 18, 2023

CONTENTS

Contents	i
PROJECT Summary	1
Gravel Extraction	2
Production Rate	2
Operational Hours	2
Staffing	2
Zoning	3
Incidental Use	3
Overview of Works	4

Tables & Figures

Table 1: Gravel extraction for Stage 1 and Stage 2	2
Table 2: Gravel extraction for block and bulk sales	2
Table 3: Details of Works Plan	4
Table 4: Construction and equipment details	4
Figure 1: Site Infrastructure, operations and DWER Prescribed Premises boundary	1
Figure 2: Location and proposed block making operations on site	5

Summary

January 18, 2023

PROJECT SUMMARY

Gravel Pit Pty Ltd (Gravel Pit) propose to develop a block making operation at their site located at 366 Horton Road, Woottating. Blocks are proposed to be supplied wholesale to markets including landscape supplies and to local trades for building of retaining walls etc. Predominantly regional market outlets, within approximately 70-kilometre radius of the site, are to be targeted including supply to the Northam, York, Mundaring areas and some eastern suburbs of Perth (closer to Great Eastern Highway). Sale of blocks will replace the majority of extracted and screened bulk gravel sales from the site's extraction activities.

Blocks will not be sold retail and the site will not be open to the general public, wholesale or commercial customers to collect blocks directly from site. Blocks will be delivered to respective customers by Gravel Pit or it's appointed contractor.

The block making will be incidental to the current gravel extraction activities conducted under Extractive Industry Licences (EILs) issued by the Shire of Northam (ref: A1271/EI12001/OPA9442 and A1271/EI21003/OPA13998).

Both EILs are current for Stage 1 and Stage 2, and the site is a Prescribed Premises licensed by the Department of Water and Environmental Regulation (DWER) for Category 12 – Screening etc. of material (ref: L9251/2020/1). Figure 1 shows Stages 1 and 2, and the Prescribed Premises boundary.

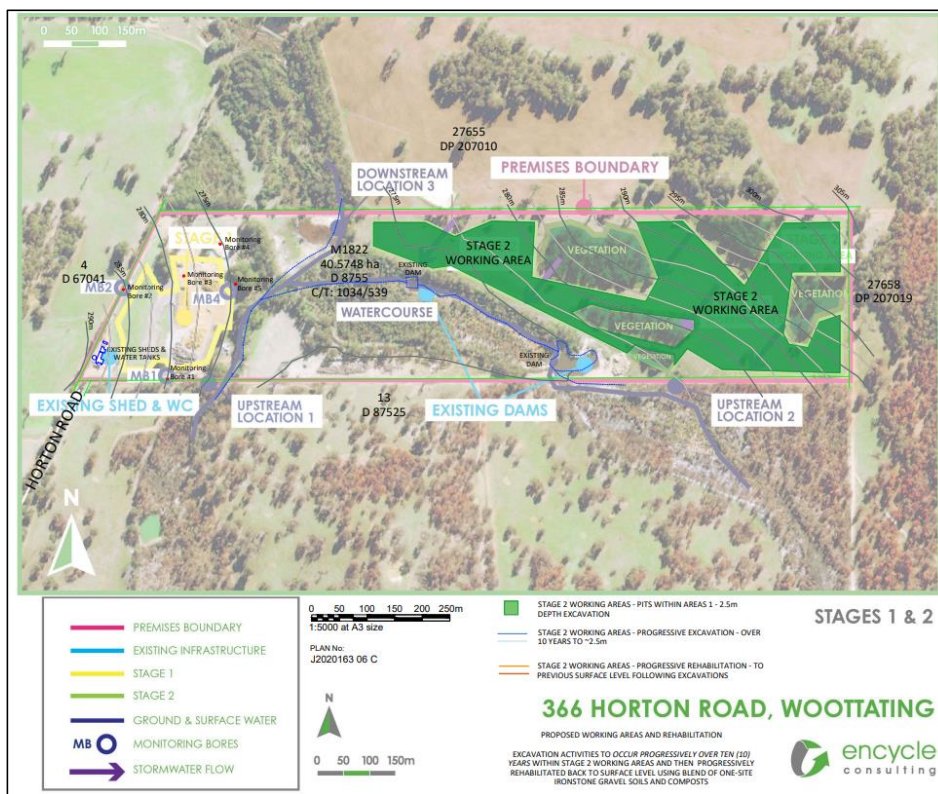

Figure 1: Site Infrastructure, operations and DWER Prescribed Premises boundary

Prepared by eva environmental

Summary

January 18, 2023

Gravel Extraction

It is proposed that sales of blocks will replace the majority of sale of bulk, loose and screened gravel from the site. The proposed product split is 98% block products and 2% bulk gravel product.

The amount of gravel extracted to date and screened for bulk sales is shown in Table 1. The proposed amount of extracted gravel for block and bulk sales is shown in Table 2.

Table 1: Gravel extraction for Stage 1 and Stage 2

Stage	Area (m ²)	Projected extraction volume (m ³) Loose	Projected extraction weight (t)*	Amount extracted to date (t)
Stage 1	29,100	72,750	94,575	41,028
Stage 2	76,000	152,000	197,600	7,000

Table 2: Proposed gravel extraction for block and bulk sales

Stage	Projected amount to be extracted (t)	Projected use for blockmaking (t)	Projected use for bulk, loose, screened gravel (t)
Stage 1	53,547	52,476	1,071
Stage 2	190,600	186,788	3,812

Production Rate

The typical block and size to be produced will be 1000 x 350 x 350mm and production rate will average about 2500 blocks produced per week allowing time for curing and space for product storage.

Operational Hours

Operational hours of between 7am and 5pm, for block making, will be maintained at the site. Allowing time for maintenance and cleaning, production hours are expected to be about 8 hours / day.

Staffing

The same number of site personnel will be employed as for the gravel extraction and bulk sales operation i.e. 3 to 4 persons.

Summary

January 18, 2023

Zoning

Under the Shire of Northam 'Local Planning Scheme No 6' (July 2013)¹, the site is zoning and use of land is "Rural".

The predominant use of the land is gravel extraction and screening of gravel under relevant Shire EILs, Development Approvals (DAs) and DWER Prescribed Premises licencing. This predominant use is provided for under extractive industries under the "Rural" zoning.

Incidental Use

The proposed block making facility is considered an incidental use as it does not change the predominant use of the land, which is extractive industries. The block making operation is consolidating extracted gravel and making blocks for wholesale and replacing sale of extracted, loose gravel.

The block making activity is to be located and confined to an area in the south west corner of Stage 1 of the site, in proximity to existing infrastructure and the site entrance / exit. The block making facility comprises a small footprint of a 2,700m² concrete hardstand encompassing the area for housing of equipment for block manufacture and dry mix plant for the mixing area. Two stormwater catchment basins are to be constructed comprising a total of 630m². Rehabilitated areas of this Stage 1 south west corner (approx. 8-10,000m²) will be further compacted with gravel extracted from site for product storage, vehicles access, vehicle and equipment movement. The proposed facility and footprint are presented in accompanying file 'J221036_DA_B current 230113' and shown in Figure 2.

The block making will operate on a wholesale supply basis with block products delivered to customers by Gravel Pit or it's appointed contractor. Delivery of block products will replace delivery of bulk gravel. Significant increases in vehicle volumes / movement are not expected with traffic movements predicted to be similar as for bulk sales, that is, 20 movements per day (during a campaign of 3-4 weeks).

Gravel Pit are to purchase a pre-owned Finlay F44 block making machine. The block making machine is not a significant piece of equipment with large throughput volumes. Predicted noise levels around the machine up to 1 m are 96 dB² with levels dissipating beyond this (similar for a diesel skid steer). The dry mix plant is electric. It is not expected that the block making machine and dry mix plant would significantly contribute to cumulative noise levels from the site.

Refer to the Works Plan submitted in conjunction with the DA 'Gravel Pit DA Works Plan v1' for details on management of site works and potential emissions.

The block making operations will be conducted in line with the site Operational Environmental Management Plan (OEMP) updated to include block making and submitted as supporting information to this DA.

¹ Available: <https://www.northam.wa.gov.au/Assets/Documents/Document-Centre/Local-Planning-Scheme-No.6/2013-Local-Planning-Scheme-No-6-TEXT.pdf>

² Refer Attachment A-Finlay F44 specs

Summary

January 18, 2023

Overview of Works

The work overview, construction and equipment details are provided in Table 3 and Table 4. A detailed Works Plan is submitted in conjunction with the DA 'Gravel Pit DA Works Plan v1' and detailed site plan 'J221036_DA_B current 230113'.

Table 3: Details of Works Plan

Detail	Description / Information
Approval sought	Development approval application
Local Government	Shire of Northam
Project	Construction a concrete 2500m ² hardstand, 2 x 315m ² drainage basin/soaks, upgrade to ablutions block, and installation of a dry mix plant and block machine (Finlay F44 block machine)
Address	366 Horton Road, Woottating
Proponent	Gravel Pit Pty Ltd
Designer	Building Lines
Work hours	7am to 5pm, Monday to Friday
Timeframe	Start mid-January, completion by end February
No. workers	Four (4)
Facilities	Use of existing onsite amenities
Plant & equipment	Loader, Excavator, Skid steer / Bobcat, Water tanker, Concrete tanker / mixer, Grader
Contact	David Markham, david@capitalperth.com.au

Table 4: Construction and equipment details

Construction / equipment	Description / Information
Concrete hardstand	Construction of 2500m ² concrete hardstand for housing of equipment and manufacturing of blocks.
Mixing hardstand	Construction of 207m ² concrete hardstand for mixing area, adjacent to manufacturing area.
Dry mix plant	Installation of dry mix plant. Gravel Pit have purchased a pre-owned Sami T3 plant. Refer to J221036_DA_B current 230113 for details of the plant.
Stormwater catchment	Construction of 2 x 315m ² drainage basins / soaks to capture water runoff from the hardstand areas. Soaks will prevent any runoff and dust impacts from the hardstand to the watercourse.
Compacted gravel areas	Areas for loading of blocks onto trucks and for screening of gravel to be compacted. Note all hardstand areas listed are to be installed where gravel extraction and rehabilitation has already been completed.
Ablutions	Refer to J221036_DA_B current 230113 for details of upgrade / modification to ablutions.
Block making equipment	Gravel Pit have purchased a pre-owned Finlay F44 Gaul block machine, specifications of which are shown in the accompanying 'Gravel Pit DA Works Plan v1' and file J221036_DA_B current 230113.

Summary

January 18, 2023

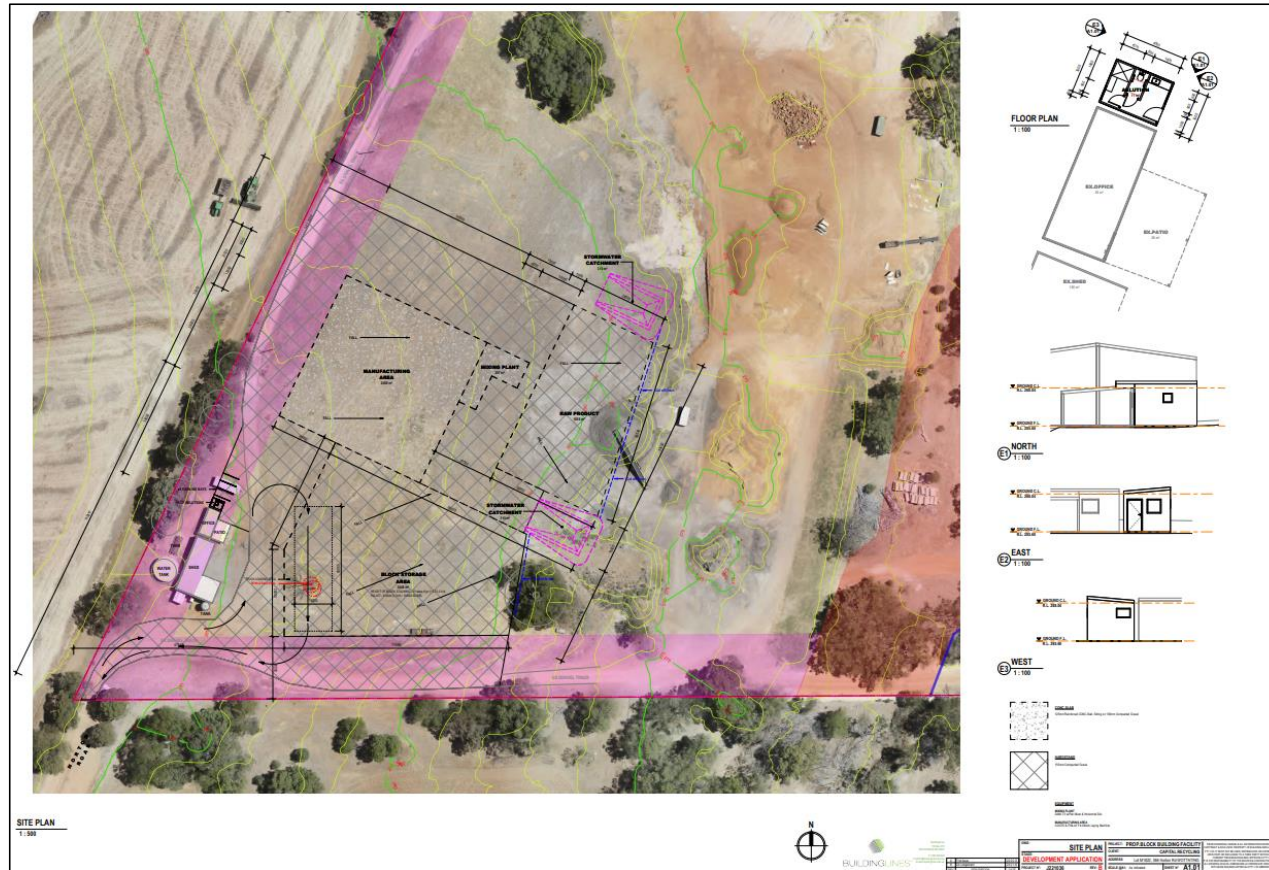

Figure 2: Location and proposed block making operations on site

Prepared by eva environmental

Works Plan Development Approval Application 366 Horton Road, Woottating

Gravel Pit Pty Ltd

19 January 2023



Issue V1

Works Plan

January 19, 2023

CONTENTS

Contents	i
1. PROJECT.....	1
1.1 Summary	1
1.2 Scope	2
1.3 Contacts.....	2
1.4 Zoning, Approvals and Operations.....	3
Incidental Use	4
1.5 Gravel Extraction	4
2. Site Characteristics	5
2.1 Site Location.....	5
2.2 Geology & Climatic Conditions	5
2.3 Receptors.....	6
3. Description of Works.....	7
3.1 Block making machine.....	9
Noise emissions	10
3.2 Dry Mix Plant.....	11
Noise emissions	11
3.3 Production rates, Staffing & Operational Hours	11
4. Site Works.....	12
4.1 Inductions.....	12
4.2 Contractor/s	12
4.3 Emergency Contacts	12
4.4 Site Access	13
5. Management Measures.....	14
5.1 Work Safety.....	14
5.2 Dust.....	14
5.3 Noise	15
5.4 Stormwater.....	15
5.5 Construction water	15
5.6 Construction Waste.....	16
5.7 Rehabilitation	16

i

Works Plan

January 19, 2023

5.8 Traffic.....	16
Operations.....	17

Tables & Figures

Table 1: Gravel extraction for Stage 1 and Stage 2	4
Table 2: Gravel extraction for block and bulk sales	4
Table 3: Details of Works Plan.....	7
Table 4: Construction and equipment details.....	7
Figure 1: Site Infrastructure, operations and DWER Prescribed Premises boundary.....	3
Figure 2: 366 Horton Road site location map.....	5
Figure 3: Average wind speed and rainfall for site locality	6
Figure 4: Receptors in a 5 kms radius to the Premises boundary	6
Figure 5: Location and proposed block making operations on site.....	8
Figure 6: Finlay block machine specifications	9
Figure 7: Noise levels at 1 m around block making machine.....	10
Figure 7: Access to site for contractors.....	13
Figure 8: Vehicle path for product collections	13
Figure 9: Extract of lease agreement on 'use of land' for Carter Road	18

Works Plan

January 19, 2023

1. PROJECT

1.1 Summary

Gravel Pit Pty Ltd (Gravel Pit) propose to develop a block making operation at their site located at 366 Horton Road, Woottating. Blocks are proposed to be supplied wholesale to markets including landscape supplies and to local trades for building of retaining walls etc. Predominantly regional market outlets, within approximately 70-kilometre radius of the site, are to be targeted including supply to the Northam, York, Mundaring areas and some eastern suburbs of Perth (closer to Great Eastern Highway).

Blocks will not be sold retail and the site will not be open to the general public, wholesale or commercial customers to collect blocks directly from site. Blocks will be delivered to respective customers by Gravel Pit or it's appointed contractor.

The block making activity is to be located and confined an area in the south west corner of the site, in proximity to existing infrastructure and the site entrance / exit. The block making facility comprises a small footprint of a 2,700m² concrete hardstand encompassing the area for housing of equipment for block manufacture and dry mix plant for the mixing area. Two stormwater catchment basins are to be constructed comprising a total of 630m². Rehabilitated areas of this Stage 1 south west corner (approx. 8-10,000m²) will be further compacted with gravel extracted from site for product storage, vehicles access, vehicle and equipment movement. The proposed facility and footprint are presented in accompanying file 'J221036_DA_B current 230113'.

Under the Shire of Northam 'Local Planning Scheme No 6' (July 2013)¹, the site zoning and use of land is "Rural". Gravel extraction activities are conducted at the site under Extractive Industry Licences (EILs) issued by the Shire of Northam (ref: A1271/EI12001/OPA9442 and A1271/EI21003/OPA13998). The site is a Prescribed Premises licensed by the Department of Water and Environmental Regulation (DWER) for Category 12 – Screening etc. of material (ref: L9251/2020/1).

The predominant use of the land is gravel extraction and screening of gravel is conducted under relevant Shire EILs, Development Approvals (DAs) and DWER Prescribed Premises licencing. The block making will be incidental to the current gravel extraction activities as it does not change the predominant use of the land, which is extractive industries.

Sale of blocks will replace the majority of sale of bulk, loose and screened gravel from the site. The proposed product split is 98% block products and 2% bulk gravel product.

The block making will operate on a wholesale supply basis with block products delivered to customers by Gravel Pit or it's appointed contractor. Delivery of block products will replace delivery of bulk gravel. Significant increases in vehicles volumes / movement are not expected with traffic movements predicted to be similar as for bulk sales, that is, up to 20 movements per day (during a campaign of 3-4 weeks).

Gravel Pit are to purchase a pre-owned Finlay F44 block making machine. The block making machine is not a significant piece of equipment with large throughput volumes. Predicted noise

¹ Available: <https://www.northam.wa.gov.au/Assets/Documents/Document-Centre/Local-Planning-Scheme-No.6/2013-Local-Planning-Scheme-No-6-TEXT.pdf>

Works Plan

January 19, 2023

levels around the machine up to 1 m are 96 dB² with levels dissipating beyond this. This is similar levels to a diesel skid steer. The dry mix plant is electric. It is not expected that the block making and dry mix would significantly contribute to cumulative noise levels.

A separate summary document is provided as accompanying documentation to the DA 'Gravel Pit DA Summary v0'.

The block making operations will be conducted in line with the site Operational Environmental Management Plan (OEMP) updated to include block making and submitted as supporting information to this DA.

1.2 Scope

This Works Plan describes construction and modification works for the proposed block making operations at 366 Horton Road, Woottating. This Works Plan is submitted to the Shire of Northam in support of Gravel Pit Pty Ltd application for Development Approval for the block making operations.

Development Approval (DA) is being sought for:

- Construction of a 2,500m² concrete hardstand
- Construction of two soaks, of 315m² each, to capture water runoff from the hardstand
- Installation of a dry mix mixing plant
- Modifications to site ablutions block
- Operation of a mobile block making machine.

Gravel Pit have engaged Building Lines to design the proposed block making operations, and eva environmental to conduct an environmental assessment and assist develop mitigation measures for any potential impacts of the construction works.

This Works Plan should be read in conjunction with the DA application form, the DA summary document, the site Operational Environmental Management Plan (OEMP) and Building Lines proposed construction plans (refer J221036_DA_B current 230113).

1.3 Contacts

Details of site contacts are:

- Ray Gullotto, Director, Gravel Pit Pty Ltd, ray@capitalperth.com.au
- David Markham, Director, Gravel Pit Pty Ltd, david@capitalperth.com.au

² Refer Attachment A-Finlay F44 specs

Works Plan

January 19, 2023

1.4 Zoning, Approvals and Operations

Under the Shire of Northam 'Local Planning Scheme No 6' (July 2013)³, the site zoning and use of land is "Rural". Under this zoning, the predominant use of the land is gravel extraction.

The block making will be incidental to the current gravel extraction activities conducted under Extractive Industry Licences (EILs) issued by the Shire of Northam (ref: A1271/EI12001/OPA9442 and A1271/EI21003/OPA13998).

Both EILs are current for Stage 1 and Stage 2, and the site is a Prescribed Premises licensed by the Department of Water and Environmental Regulation (DWER) for Category 12 – Screening etc. of material (ref: L9251/2020/1). Figure 1 shows Stages 1 and 2, and the Prescribed Premises boundary.

DWER were contacted to discuss any licence requirements for the proposed block making operations. Given that there are no concrete or cement additives required in the block making process, and no refracting in a furnace, kiln etc., it would be unlikely trigger assessment through a works approval or licence amendment application⁴.

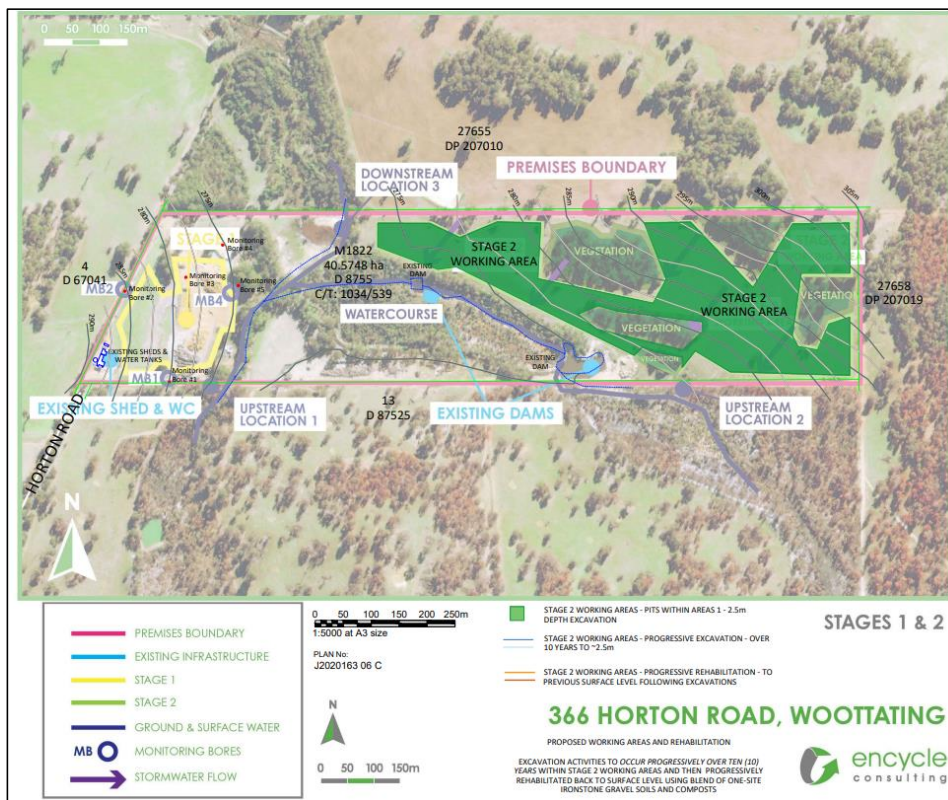

Figure 1: Site Infrastructure, operations and DWER Prescribed Premises boundary

³ Available: <https://www.northam.wa.gov.au/Assets/Documents/Document-Centre/Local-Planning-Scheme-No.6/2013-Local-Planning-Scheme-No-6-TEXT.pdf>

⁴ Email from DWER to eva environmental, dated 29 November 2022

Works Plan

January 19, 2023

Incidental Use

The proposed block making facility is considered an incidental use as it does not change the predominant use of the land, which is extractive industries. The block making operation is consolidating extracted gravel and making blocks for sale and replacing sale of extracted, loose gravel.

The block making will operate on a wholesale supply basis with block products delivered to customers by Gravel Pit or its appointed contractor. Delivery of block products will replace delivery of bulk gravel. Significant increases in vehicles volumes / movement are not expected with traffic movements predicted to be similar as for bulk sales, that is, up to 20 movements per day (during a campaign of 3-4 weeks).

Gravel Pit are to purchase a pre-owned Finlay F44 block making machine. The block making machine is not a significant piece of equipment with large throughput volumes. Predicted noise levels around the machine up to 1 m are 96 dB⁵ with levels dissipating beyond this. The dry mix plant is electric. It is not expected that the block making or dry mix plant would significantly contribute to cumulative noise levels from the site.

The production rate is estimated at 2500 per week (during a campaign basis of 3 – 4 weeks). Operational hours are to be 7am to 5pm and the number of staff will remain the same as for the gravel extraction and bulk sales operation at 3-4 personnel.

1.5 Gravel Extraction

It is proposed that sales of blocks will replace the majority of sale of bulk, loose and screened gravel from the site. The proposed product split is 98% block products and 2% bulk gravel product.

The amount of gravel extracted to date and screened for bulk sales is shown in Table 1. The proposed amount of extracted gravel for block and bulk sales is shown in Table 2.

Table 1: Gravel extraction for Stage 1 and Stage 2

Stage	Area (m ²)	Projected extraction volume (m ³) Loose	Projected extraction weight (t)*	Amount extracted to date (t)
Stage 1	29,100	72,750	94,575	41,028
Stage 2	76,000	152,000	197,600	7,000

Table 2: Gravel extraction for block and bulk sales

Stage	Projected amount to be extracted (t)	Projected use for blockmaking (t)	Projected use for bulk, loose, screened gravel (t)
Stage 1	53,547	52,476	1,071
Stage 2	190,600	186,788	3,812

⁵ Refer Attachment A-Finlay F44 specs

Works Plan

January 19, 2023

2. SITE CHARACTERISTICS

Site characteristics relevant to the block making DA are outlined below. The OEMP developed for the extraction and screening activities, and the proposed block making activities provides further detail on site characteristics, receptors and management of potential emission from operational activities.

2.1 Site Location

The site is located on Lot M1822, 366 Horton Road, Woottating in the Shire of Northam.

It is approximately 55 kms east of Perth and access is via the Great Eastern Highway and via the private Carter Road (Figure 2) with agreed private access.

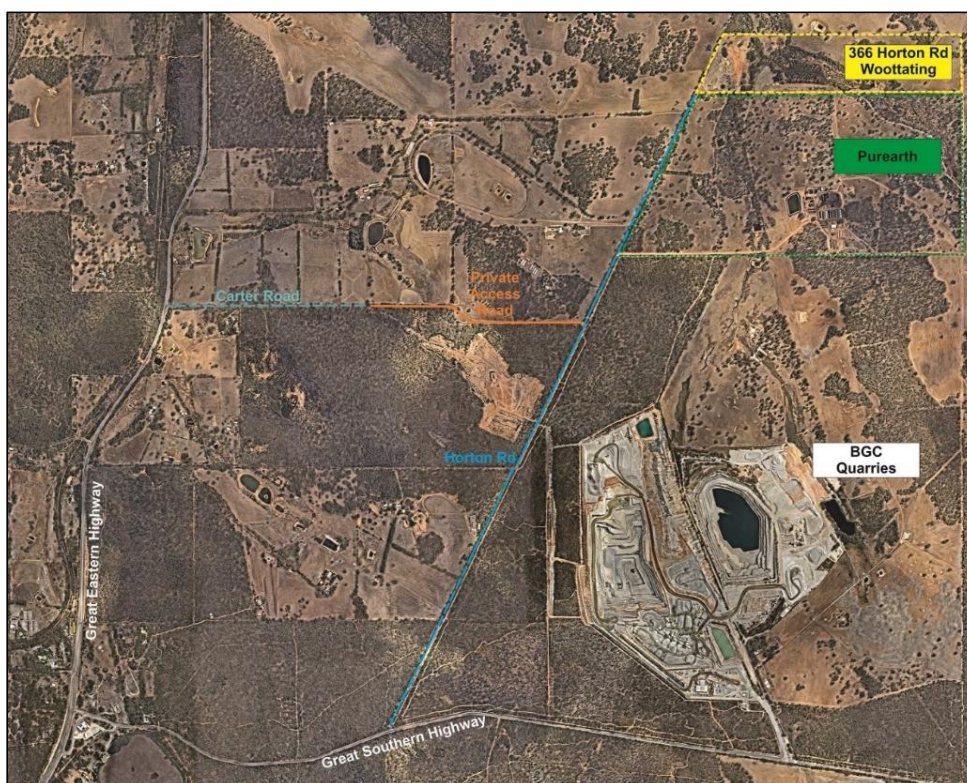

Figure 2: 366 Horton Road site location map

2.2 Geology & Climatic Conditions

The site is raised at the west and east boundaries with a valley running approximately south to north through the lot 300 m away from the western boundary. The geology of the area was mapped by the Geological Survey of Western Australia and is recorded as being underlain by granite and laterite deposit entering from the south west boundary.

Prepared by eva environmental

5

Works Plan

January 19, 2023

The site consists of lateritic gravelly soils of the Darling Plateau. Underlying this layer is granite and laterite deposits. The site also contains a narrow shallow valley floor of fluvial origin and a surface of planation and lateritic uplands of denudational origins. The small creek bed contained within the lot is a minor non-perennial waterbody and is called Wooroloo Brook.

The climatic conditions have been reviewed based on data from the Bureau of Meteorology Bakers Hill weather station, accessed in December 2022. Discussion with Gravel Pit's Director from observation on site indicates that winds are predominantly east to south-east in the mornings switching to south-west in the afternoons. In cooler months, winds tend to be from westerly or northerly directions.

The mean rainfall, from data from years 1964 to 2019 shows that rainfall is higher over the months May to August with the highest levels being in July.

Statistics	Jan	Feb	Mar	Apr	May	Jun	Jul	Aug	Sep	Oct	Nov	Dec	Annual	Years	
Temperature															
Mean maximum temperature (°C)	31.8	31.7	28.5	23.5	19.2	16.0	15.1	15.6	17.5	21.7	25.6	29.9	23.0	21	1965 1985
Mean minimum temperature (°C)	15.7	16.1	14.6	12.3	9.4	7.6	6.6	6.4	7.0	8.9	11.2	14.0	10.8	20	1965 1985
Rainfall															
Mean rainfall (mm)	20.5	15.6	18.8	30.3	69.1	102.8	110.4	88.7	62.2	33.4	19.8	11.3	597.2	38	1964 2019
Decile 5 (median) rainfall (mm)	3.6	6.1	12.4	27.3	63.1	100.8	102.7	85.7	58.5	31.9	13.3	5.4	593.4	52	1964 2019
Mean number of days of rain ≥ 1 mm	1.6	1.6	1.9	4.2	7.3	10.2	11.1	10.2	8.2	4.9	3.1	1.8	66.1	52	1964 2019
Other daily elements															
Mean daily sunshine (hours)	11.1	10.0	9.2	7.1	6.2	5.0	5.4	6.4	7.3	9.0	10.0	10.9	8.1	20	1966 1985
Mean number of clear days															
Mean number of cloudy days															
9 am conditions															
Mean 9am temperature (°C)	22.5	22.1	20.0	16.7	13.4	11.1	10.0	10.5	12.3	15.4	18.4	21.5	16.2	21	1965 1985
Mean 9am relative humidity (%)	57	61	63	71	79	85	86	85	79	69	63	57	71	14	1965 1985
Mean 9am wind speed (km/h)	20.1	20.9	19.1	14.7	12.1	10.6	10.8	13.0	15.6	18.3	19.4	18.0	16.0	20	1965 1985

Figure 3: Average wind speed and rainfall for site locality

2.3 Receptors

The site is surrounded by rural properties used for cropping, sheep or cattle grazing with the closest residential receptor 830 m south west of the site, refer Figure 4 and OEMP.

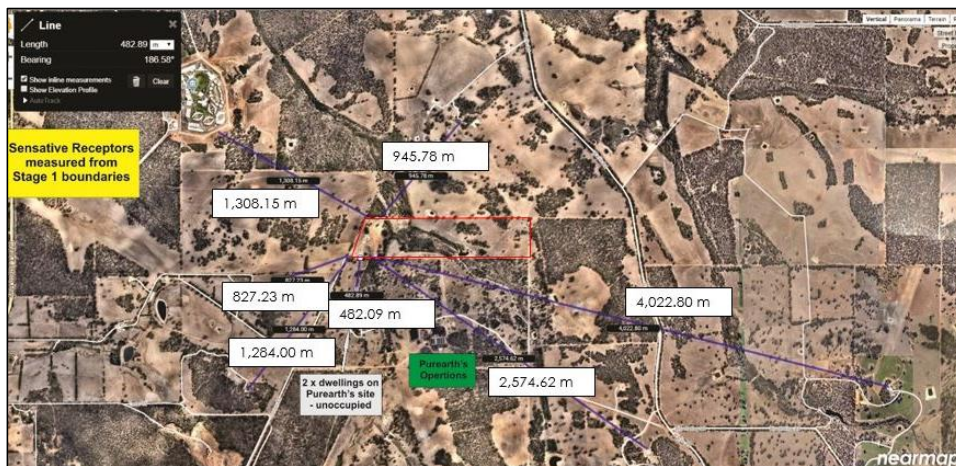

Figure 4: Receptors in a 5 kms radius to the Premises boundary

Prepared by eva environmental

Works Plan

January 19, 2023

3. DESCRIPTION OF WORKS

Details of the DA being sought are provided in Table 3 and Table 4 with the proposed activities shown on Figure 5.

Table 3: Details of Works Plan

Detail	Description / Information
Approval sought	Development approval application
Local Government	Shire of Northam
Project	Construction a concrete 2500m ² hardstand, 2 x 315m ² drainage basin/soaks, upgrade to ablutions block, and installation of a dry mix plant and block machine (Finlay F44 block machine)
Address	366 Horton Road, Woottating
Proponent	Gravel Pit Pty Ltd
Designer	Building Lines
Work hours	7am to 5pm, Monday to Friday
Timeframe	Start mid-January, completion by end February
No. workers	Four (4)
Facilities	Use of existing onsite amenities
Plant & equipment	Loader, Excavator, Skid steer / Bobcat, Water tanker, Concrete tanker / mixer, Grader
Contact	David Markham, david@capitalperth.com.au

Table 4: Construction and equipment details

Construction / equipment	Description / Information
Concrete hardstand	Construction of 2500m ² concrete hardstand for housing of equipment and manufacturing of blocks.
Mixing hardstand	Construction of 207m ² concrete hardstand for mixing area, adjacent to manufacturing area.
Dry mix plant	Installation of dry mix plant. Gravel Pit have purchased a pre-owned Sami T3 plant. Refer to J221036_DA_B current 230113 for details of the plant.
Stormwater catchment	Construction of 2 x 315m ² drainage basins / soaks to capture water runoff from the hardstand areas. Soaks will prevent any runoff and dust impacts from the hardstand to the watercourse.
Compacted gravel areas	Areas for loading of blocks onto trucks and for screening of gravel to be compacted. Note all hardstand areas listed are to be installed where gravel extraction and rehabilitation has already been completed.
Ablutions	Refer to J221036_DA_B current 230113 for details of upgrade / modification to ablutions.
Block making equipment	Gravel Pit have purchased a pre-owned Finlay F44 Gaul block machine, specifications of which are shown in Figure 6 and in accompanying file J221036_DA_B current 230113.

Works Plan

January 19, 2023

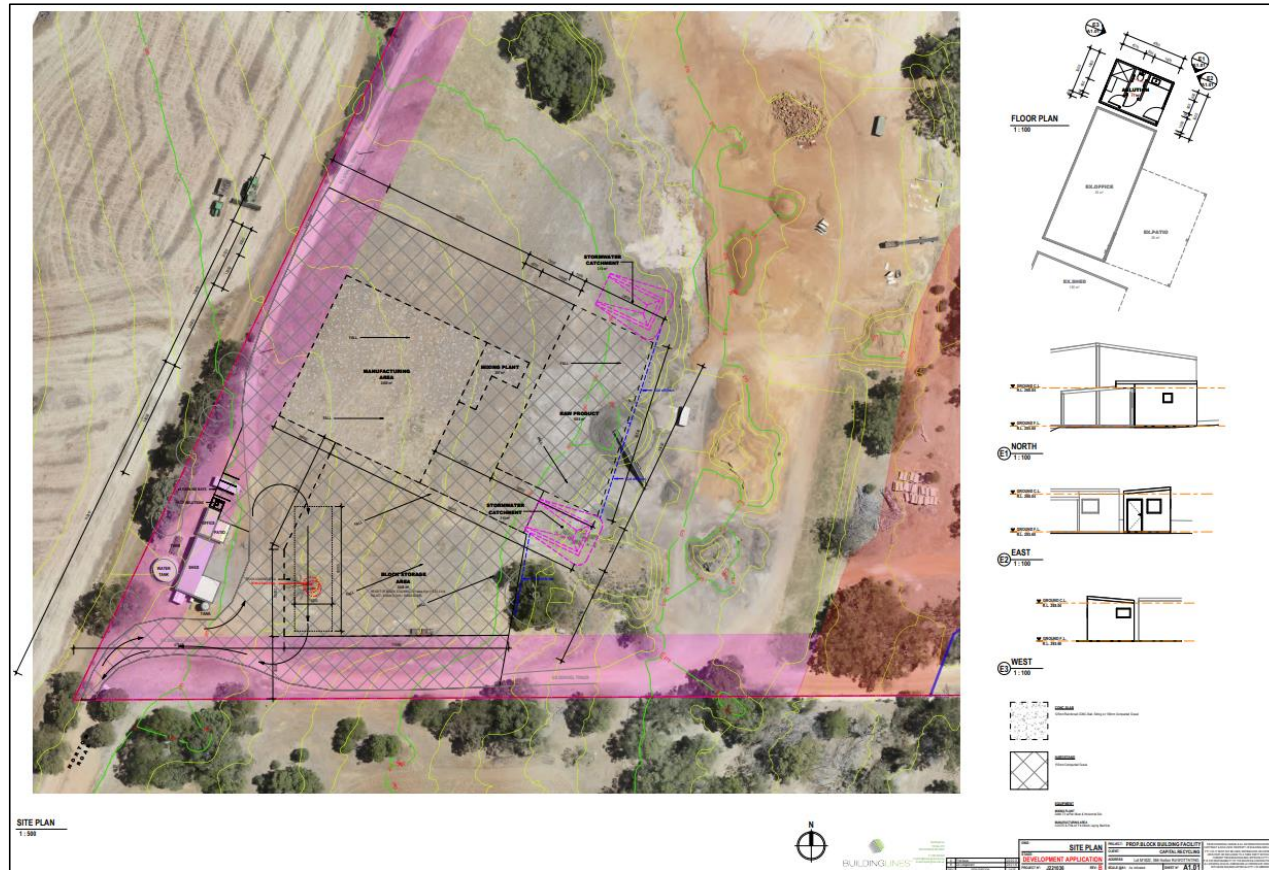

Prepared by eva environmental

Works Plan

January 19, 2023

3.1 Block making machine

Gravel Pit have purchased a pre-owned Finlay F44 Gaul block machine, specifications of which are shown in Figure 6. Photos of a new version of the machine from Finlay are show in photos 1 and 2.



Figure 6: Finlay block machine specifications

Prepared by eva environmental

Works Plan

January 19, 2023

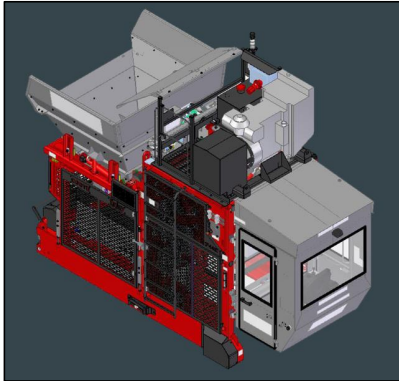

Photo 1: F44 block machine illustration



Photo 2: F44 block machine & typical block types

Noise emissions

In terms of noise potential emissions, the block making machine is not a significant piece of equipment with large throughput volumes.

Predicted noise levels around the machine up to 1 m are 96 dB⁶ with levels dissipating beyond this (which is similar for a diesel skid steer).

It is not expected that the block making machine would significantly contribute to cumulative noise levels from the site.

Figure 7: Noise levels at 1 m around block making machine

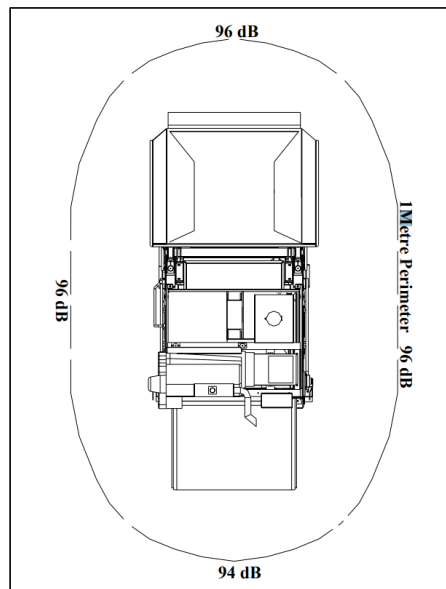

⁶ Refer Attachment A-Finlay F44 specs

Prepared by eva environmental

Works Plan

January 19, 2023

3.2 Dry Mix Plant

Gravel Pit have purchased a pre-owned Sami T3 plant, which consists of a 3-bin system, each with a capacity of 4.5m³ (refer photo 3).



Photo 3: Dry mix plant

Noise emissions

The dry mix plant is electric, refer to J221036_DA_B current 230113 for specifications. Noise from the dry mix plant is not expected to significantly contribute to cumulative noise levels from the site.

Refer to the site OEMP for operational management and mitigation measures for noise.

3.3 Production rates, Staffing & Operational Hours

The typical block and size to be produced will be 1000 x 350 x 350mm and the production rate will average about 2500 blocks produced per week; allowing time for curing and space for product storage.

Operational hours of between 7am and 5pm will be maintained at the site. Allowing time for maintenance and cleaning, production hours are expected to be about 8 hours / day.

Staffing levels will be the same as for gravel operations at 3-4 site personnel.

It is noted that block making operations will be undertaken to meet sales contracts and also to align with campaigns for extraction and screening of gravel. Usually, extraction and screening of gravel is undertaken on a campaign basis (over 3 to 4 weeks) and may be limited during time of more inclement or stormy weather.

Works Plan

January 19, 2023

4. SITE WORKS

4.1 Inductions

Site inductions will be given to all contractors and sub contactors, and suppliers if/when required. Inductions will include safety and environment and at a minimum will include:

- Occupational health & safety
- Operating equipment
- Operating heavy machinery
- Dust emissions / generation
- Noise emissions / generation
- Aboriginal, European and Australian heritage
- Accidental spillage e.g. refuelling
- Incident reporting
- Emergency response procedures.

The Site Supervisor is responsible for ensuring all contractors have received a site induction before commencing work. Records of this induction will be maintained by the Site Supervisor along with any relevant training records.

4.2 Contractor/s

The contractors/workers will implement all reasonable and practical measures to prevent or minimise the generation of dust during all tasks at all times of the Works. The contractor shall be bound to the Department of Environment's publication, *A Guideline for the Prevention of Dust and Smoke Pollution from Land Development Sites in Western Australia (November 1996)*.

The contractor/s will comply with the Environment Protection Authority, *Environmental Protection (Noise) Regulation 1997*.

The contractor/s will comply with the Aboriginal Heritage Act 1972.

Site safety when undertaking the works shall be the responsibility of the contractor. The contractor/s will determine appropriate safe working procedures and methodologies to construct the works as specified.

Gravel Pit will provide access to supply of electricity during the works to the contractor/s.

Gravel Pit will provide access to ablution and lunch room facilities and potable water for workers during the working program.

4.3 Emergency Contacts

Name	Role	Contact phone
Ambulance, Fire, Police	Emergency Response	000
Gravel Pit	David Markham	TBA
First Aid Officer	Appointed site personnel	TBA

Works Plan

January 19, 2023

5. MANAGEMENT MEASURES

For site works that have the potential to impact on safety and environment, control measures have been identified to be put in place by Gravel Pit.

5.1 Work Safety

- Site safety when undertaking the works shall be the responsibility of the contractor
- The contractor/s will determine appropriate safe working procedures and methodologies to construct the works as specified
- Safe working distance to be maintained around plant & equipment
- Minimum Personal Protective Equipment (PPE) requirements for all visitors to the site are protective footwear, high visibility clothing (vest or jacket), long sleeved shirt and full-length trousers.
- Signage indicating no unauthorized access during operations. Site visitors must report to site supervisor but not enter working areas until accompanied by a site employee

5.2 Dust

The potential impact on residential receptors is expected to be low given that the closest residence is 830 m from the Premises south-west boundary and winds are generally light to moderate across the site. Further the block making machine and dry mix plant are not expected to contribute significantly to noise emission given the low noise emissions and electric nature of the block machine and dry mix plant respectively.

Mitigation measures include:

- Site personnel will undertake a site-specific induction including use of Personal Protective Equipment (PPE) to prevent health hazards and exposure to dust emissions
- The Site Supervisor will monitor wind conditions daily using weather app (e.g. Willy Weather) to assess wind strength and direction. In the event of strong winds (>25 Knots) and in particular in the direction of the closest sensitive receptor, scheduling of operations with reduced potential for dust generation
- Truck mounted sprays will water unsealed, regularly trafficked areas such as access tracks, work areas and haul roads as conditions require
- Routine housekeeping practices will be employed to ensure that spillages and other materials that could contribute to dust generation do not accumulate within the boundary
- In the event that dust migrates beyond the Premises boundary, dust suppression measures will be immediately reviewed to ensure practices are being followed and / or to implement more stringent measures. Such measures could include the cessation of activities in the event of extreme adverse weather conditions
- Block making machine and dry mix plant will be housed on concrete hardstand whereby any water runoff and captured dust will be directed to two soaks preventing flow and impact to the water course
- Activities will be located more than 20m inside of the boundary
- The water course exclusion zone of 40m will be maintained

Works Plan

January 19, 2023

- All personnel (including contractors) will be informed of their responsibilities and the importance of minimising ambient dust and noise levels during site inductions
- Activities are to occur only between 7am and 5pm.

5.3 Noise

The potential impact on residential receptors is expected to be low given that the closest residence is 830 m from the Premises south-west boundary and winds are generally light to moderate across the site.

Further the block making machine and dry mix plant are not expected to contribute significantly to noise emission given the low noise emissions and electric nature of the block machine and dry mix plant respectively, and activities are undertaken on a campaign, not continuous basis.

Mitigation measures include:

- Site personnel will undertake a site-specific induction including use of Personal Protective Equipment (PPE) to prevent health hazards, and especially within 1m of block making machine
- The Site Supervisor will monitor wind conditions daily using weather app (e.g. Willy Weather) to assess wind strength and direction. In the event of strong winds (>25 Knots) and in particular in the direction of the closest sensitive receptor, scheduling of operations to reduce potential for noise to carry will be assessed
- All plant (e.g. loaders) will be fitted with "croakers" to reduce high-pitched noise migration
- Block making machine and dry mix plant to be regularly serviced and cleaned to maintain good operating conditions
- Activities will be located more than 20m inside of the boundary
- All personnel (including contractors) will be informed of their responsibilities and the importance of minimising ambient dust and noise levels during site inductions
- Block making to occur between 7am and 5pm.

5.4 Stormwater

Given the timing of the Works Plan, it is unlikely that stormwater and possible sediment flow to the water course will need to be managed.

In the unlikely event stormwater will need to be managed, the measures include:

- Stormwater will be managed on site and will not be allowed to flow off-site by constructing temporary gravel contours / bunds to prevent the follow of water off-site
- All spills will be cleaned up immediately using appropriate methods and materials.

5.5 Construction water

Wash outs from the concrete trucks will be into a temporary clay lined pit which will be excavated and loaded out to a Capital Recycling yard on completion of works. Pits will be constructed so as not to impact the water course.

Works Plan

January 19, 2023

5.6 Construction Waste

Management of all waste streams during the construction process is the responsibility of the Site Supervisor. Appropriate waste bins/receptacle will be made available and material source separated to maximise recycling.

Measures include:

- Clearly label waste receptacles and locate them in convenient, accessible areas
- Ensure waste receptacles have appropriate lids/covers
- Ensure waste receptacles are emptied at an appropriate rate;
- Educate contractors in correct use of bins.

5.7 Rehabilitation

Stage 1 working areas that have had gravel excavated have been rehabilitated and backfilled with gravel/soil and pits brought back up to surface levels. Gravel has been compacted in these excavated pits. The proposed block making operations is located on top of these already excavated and rehabilitated areas.

Refer areas shown as below 'conc slab' and 'hardstand' on J221036_DA_B current 230113.



Any further extractions and rehabilitation at Stage 1 and Stage 2 will be conducted in line with the relevant EIL condition/s.

5.8 Traffic

Gravel Pit have a lease agreement with their neighbouring property at Lot 9249 Carter Road, which is current and allows access to the site via this private road which connects with Great Eastern Highway (refer Figure 9).

Construction vehicles are not expected to be extensive and will be mobilised to site, undertake site works and then demobilised thereby limiting vehicle movements on a daily basis.

Operationally as the extracted gravel is being consolidated to produce blocks, the number of vehicles accessing the site and collecting product is not expected to increase from bulk distribution of product. The expected number, during campaigns, may be 20 vehicle movements per day. Refer to OEMP for further details on traffic management measure for operations.

Traffic measures during construction works include:

- Use of Carter Road and Great Eastern Highway for site access
- Strictly no access for trucks on southern end of Horton Road (same traffic management plan as Capital Recycling and Pure Earth trucks.

Works Plan

January 19, 2023

- 40km/h speed limits on Cater and Horton roads
- Truck speed bumps on Private Access and Horton Roads
- Induct and brief drivers and contractors on the local operational requirements to minimise impact on Carter Road and Horton Road
- Induct and brief drivers to enter and exit the site via Great Eastern Highway / Carter Road intersection only to mitigate the potential impact on local roads
- Use water truck to wet down unsealed roads.

Operations

The Traffic Impact Statement⁷ provided as supporting documentation to the EIL and DWER licence applications, has been reviewed with consideration to gravel operations, collection and delivery of blocks from site. The assessment of up to 20 vehicle movements per day during operational hours (and during campaigns) is considered relevant and conservative given that fewer vehicle movements may occur with the gravel being compacted into blocks than being collected in a bulk and loose form. Note that the predominant use of extracted will be for block making (at 98%) rather than bulk gravel (at 2%).

Staff vehicles will remain the same at 3-4 passenger vehicles.

No significant changes have been made to the Great Eastern Highway and lease agreement between Capital Recycling and their neighbouring property at Lot 9249 Carter Road is current (as provided in the extract in **Figure 10**).

Refer to the site OEMP for operational management and mitigation measure for traffic.

⁷ Refer supporting documentation to EILs, 'Traffic Impact Statement', (Shawmac, 2013)

Works Plan

January 19, 2023

6. USE OF LAND

The Tenant:

- (a) must use the Land only for the Permitted Use set out at Item 11 of the Schedule;
- (b) must comply on time with all laws and the requirements of authorities in connection with the Land at its sole cost and expense;
- (c) may fully use the Land as a road and pass and repass over it with or without any form of vehicle or machinery and may allow any third parties requiring access to or from the Tenant's premises at lot 13 on Diagram 87525 being the whole of the land in certificate of title volume 2026 folio 553 to do the same;
- (d) may only use the land between 7.00am and 7.00pm;
- (e) shall ensure that the gates to the road are kept locked except during the hours authorised in clause 6(d) above;
- (f) must take all reasonable steps to minimise the nuisance the Landlord caused by the use of the Land as a road including but not limited to minimisation of dust and noise from the Land; and
- (g) must use its best endeavours to restrict speed of travel along the Land to 50km/hr by:
 - (i) erecting maximum speed signs;
 - (ii) if necessary the installation of speed humps sufficient to restrict speed on the Land to 50km/hr; and
 - (iii) the erection of a stop sign at the entry point of vehicles onto the road.

Figure 10: Extract of lease agreement on 'use of land' for Carter Road



Operational Environmental Management Plan
Gravel Pit, 366 Horton Road, Woottating

Version	Reviewed by	Issued	Revision/s
0	D Markham	21/12/2022	Inclusion of proposed block making activities

Table of contents

1	Context	5
1.1	Document Scope	5
1.2	Organisational Profile	6
1.3	Contacts	6
1.4	Site, Infrastructure and Operations	6
1.4.1	Boundary set backs	8
2	Environmental Policy	9
3	Overview of Site Characteristics	10
3.1	Location	10
3.2	Receptors	11
3.3	Climatic Conditions	12
3.4	Geology & Hydrology	13
4	Dust Management Plan	14
4.1	Potential Emissions	14
4.2	Risk Assessment	15
4.3	Objectives	17
4.4	Management of potential dust emissions	17
4.4.1	Site management	17
4.4.2	Management by Operational Activity	18
4.5	Monitoring	20
5	Noise Management	21
5.1	Potential Emissions	21
5.2	Risk Assessment	22
5.2.1	Block making machine	23
5.3	Objectives	24
5.4	Management of potential noise emissions	24
5.4.1	Site management	24
5.4.2	Management by Operational Activity	25
5.5	Monitoring	27
6	Water Management	29

6.1	Potential Emissions	29
6.2	Risk Assessment.....	30
6.3	Objectives.....	30
6.4	Site characteristics, engineering & operational measures	31
6.4.1	Climatic and Site characteristics	31
6.4.2	Engineering and operational measures	31
7	Rehabilitation Plan.....	32
7.1	Gravel Extraction Operations	32
7.1.1	Exclusion zones.....	33
7.1.2	Duration	34
7.1.3	Process flow	35
7.1.4	Topsoil stripping	36
7.1.5	Gravel extraction	36
7.1.6	Constructing gradient stability	36
7.2	Rehabilitation Measures	36
7.2.1	Objective.....	36
7.2.2	Surrounding land uses	36
7.2.3	Procedures	37
7.3	Weed Management Measures	38
7.3.1	Definition of weeds	38
7.3.2	Current weed status	39
7.3.3	Objectives.....	39
7.3.4	Weed management zones	39
7.3.5	Weed control program	39
8	Traffic Management Measures	40
8.1	Objective.....	40
8.2	Assessments / Access	40
8.3	Procedures	41
9	Fire Management.....	42
10	Environmental Complaints Register	43
11	Training & Record Keeping	45

11.1	Training.....	45
11.2	Reporting.....	45
11.2.1	Dust	45
11.2.2	Noise	45
11.2.3	Water	45
Appendix A Weed Species		46
Appendix B Material Acceptance Procedure.....		48
List of Figures		
Figure 1: Site Infrastructure, operations and DWER Prescribed Premises boundary		7
Figure 2: Proposed block making operations on site		7
Figure 3: Boundary and watercourse setbacks.....		8
Figure 4: 366 Horton Road site location map.....		10
Figure 5: Receptors in a 5 kms radius to the Premises boundary		11
Figure 6: Average wind speed and rainfall for site locality.....		13
Figure 7: Potential dust emissions from gravel pit operations		14
Figure 8: Activities generating noise		21
Figure 9: Noise levels at 1 m around block making machine.....		23
Figure 10: Potential emissions to surface / ground water from operations		29
Figure 11: Stage 1 and Stage 2 gravel extraction areas.....		32
Figure 12: Stage 1 gravel extraction boundary exclusion areas (pink and red shaded areas).....		33
Figure 13: Stage 2 gravel extraction boundary exclusion areas (pink and red shaded areas).....		33
Figure 14: Gravel extraction process flow		35
Figure 15: Extract of lease agreement on 'use of land' for Carter Road		40
List of Tables		
Table 1: Gravel extraction for Stage 1 and Stage 2.....		6
Table 2: Receptors to the Premises		11
Table 3: Part A - Nature of the site.....		15
Table 4: Part B – Proximity of site to other land uses		16
Table 5: Dust management for Operational Activities.....		18
Table 6: Extract from VIPAC and Bowman (2013) noise impact assessment.....		22
Table 7: Noise management for Operational Activities		25
Table 8: Surface and groundwater monitoring locations and parameters		30

1 Context

This Operational Environmental Management Plan has been developed to identify and mitigate potential environmental emissions at Capital Recycling's site, the Gravel Pit, at 366 Horton Road, Woottating.

1.1 Document Scope

The scope of this Operational Environmental Management Plan (OEMP) is to outline proposed measures to mitigate potential emissions and discharges identified from operational activities at the Gravel Pit, 366 Horton Road, Woottating.

This document also serves to outline measures for relevant Shire of Northam planning approvals and extractive industry licenses (EILs), Department of Water and Environmental Regulation (DWER) Prescribed Premises licence, Department of Planning, Lands and Heritage (DPLH), WA Planning Commission (WAPC) and Department of Fire and Emergency Services (DFES) measures in relation to 'Guidelines for Planning in Bushfire Prone Areas'¹.

This OEMP draws on:

- Building Lines proposed site design for block making operations (J221036_DA_B current 230113)
- Correspondence with the Shire of Northam and DWER on beds / banks permit for the site, October to December 2022
- Detailed survey maps undertaken by Total Project Consultants in June and December 2021
- Meeting with the Shire of Northam Planning Services and Environmental Services, Capital Perth and Encycle on site on Thursday, 18 November 2021 and Wednesday, 26 August 2020
- Environmental, ecological and receptors desktop review and site visit undertaken by Encycle Consulting for the new Category 12 Prescribed Premises licence on Thursday, 20 August 2020 (L9251)
- Investigations, site assessments and background reports commissioned by Capital Recycling for the DWER Category 12 Prescribed Premises licence (L9251), Stage 1 and 2 EIL and planning approval for Stage 2 EIL by the Shire of Northam, including:
 - Bushfire Protection Australia (July 2020), 'Bushfire Management Statement: 366 Horton Road'
 - Shawmac (January 2013), 'Traffic Impact Statement: Lot M1822'
 - Bowman & Associates (October 2012), 'Private entry road design'
 - VIPAC Engineers & Scientists (2009), 'Memorandum – Environmental Noise Assessment'

¹ DPLH & WAPC (2021), 'Guidelines for Planning in Bushfire Prone Areas' version 1.4, available: https://www.wa.gov.au/system/files/2022-05/Guidelines-for-planning-in-bushfire-prone-areas-version-1.4_0.pdf, Accessed: December 2022

1.2 Organisational Profile

Capital Recycling began operation in 1996 as a drainage and earthmoving operation and moved into demolition work. Following a number of years in this arena, the company was well positioned to recognise the significant amount of waste generated in the construction industry and the potential this waste had as a reusable or recycled commodity.

Capital Recycling focuses on efficient materials processing. The maintenance of a clean, safe and progressive work environment contributes to the company's reputation in the residential, commercial and industrial waste reclamation industry. Currently, a range of high quality, recycled products including crushed concrete road-base, track and drainage material and fill sand is produced. This range of recycled products has been enhanced by the use of extracted gravel from its Woottating operations as a feedstock to a number of products. Capital Recycling now propose to expand operations, under Gravel Pit Pty Ltd at their site at 366 Horton Road, Woottating to develop a block making operation for sale of blocks to the local landscaping and construction sector.

On the service side, Capital Recycling offers selected building waste facilities, on-site crushing and screening, building waste transportation, site remediation works and Class 1 demolition services.

1.3 Contacts

David Markham, General Manager, Capital Recycling, Email: david@capitalrecycling.com.au.

Ray Gullotto, Managing Director, Capital Recycling, Email: ray@capitalrecycling.com.au.

1.4 Site, Infrastructure and Operations

The site infrastructure, Prescribed Premises boundary, Stage 1 and Stage 2 gravel extraction areas are shown in Figure 1.

Specifically, operations conducted at the site are:

- Gravel extraction and screening
- Bulk product distribution
- Proposed block making operations and product distribution.

The amount of gravel extracted to date is shown in Table 1. The proposed split from 2023 for gravel and block products sales is 2% bulk gravel product and 98% block products.

Table 1: Gravel extraction for Stage 1 and Stage 2

Stage	Area (m ²)	Projected extraction volume (m ³) Loose	Projected extraction weight (t)*	Amount extracted to date (t)
Stage 1	29,100	72,750	94,575	41,028
Stage 2	76,000	152,000	197,600	7,000

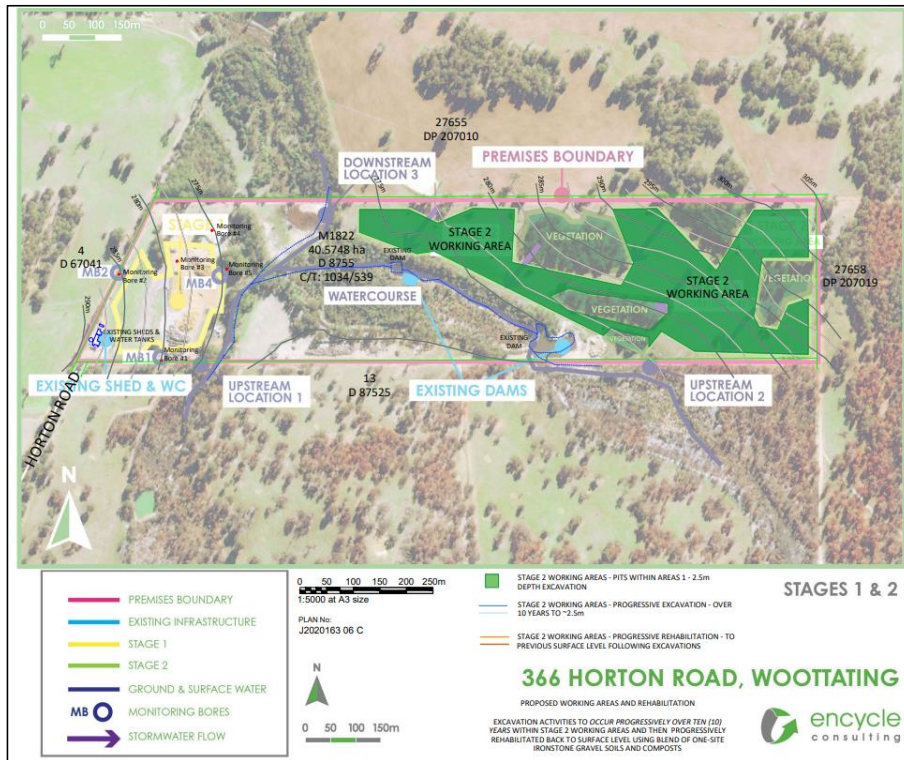

Figure 1: Site Infrastructure, operations and DWER Prescribed Premises boundary

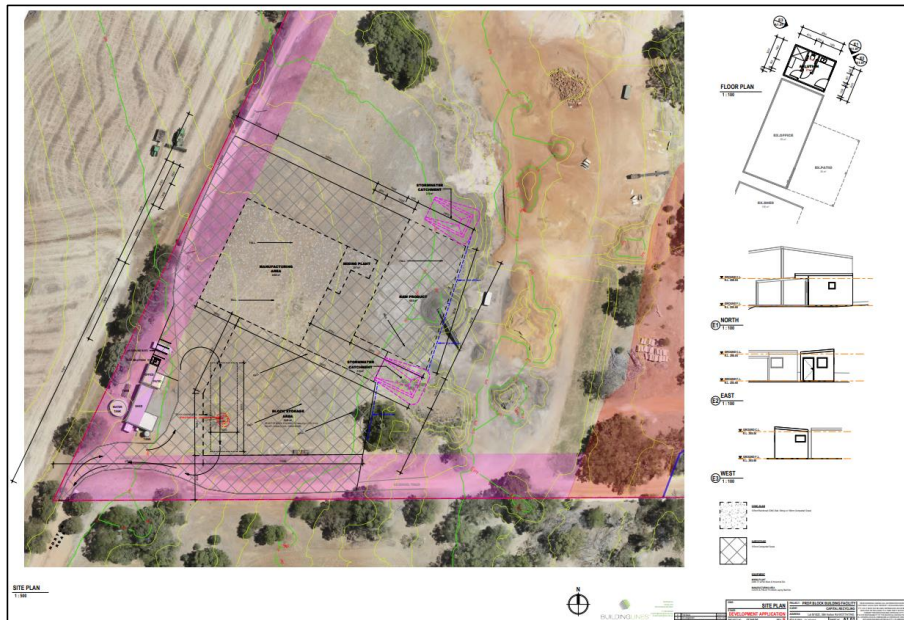

Figure 2: Proposed block making operations on site

1.4.1 Boundary set backs

Figure 3 shows the DWER prescribed premises boundary with the 20 m set back from the boundary line (shaded pink area), and the 50 m exclusion zone left and right of the mid line of the mapped and surveyed water course (red shaded area).

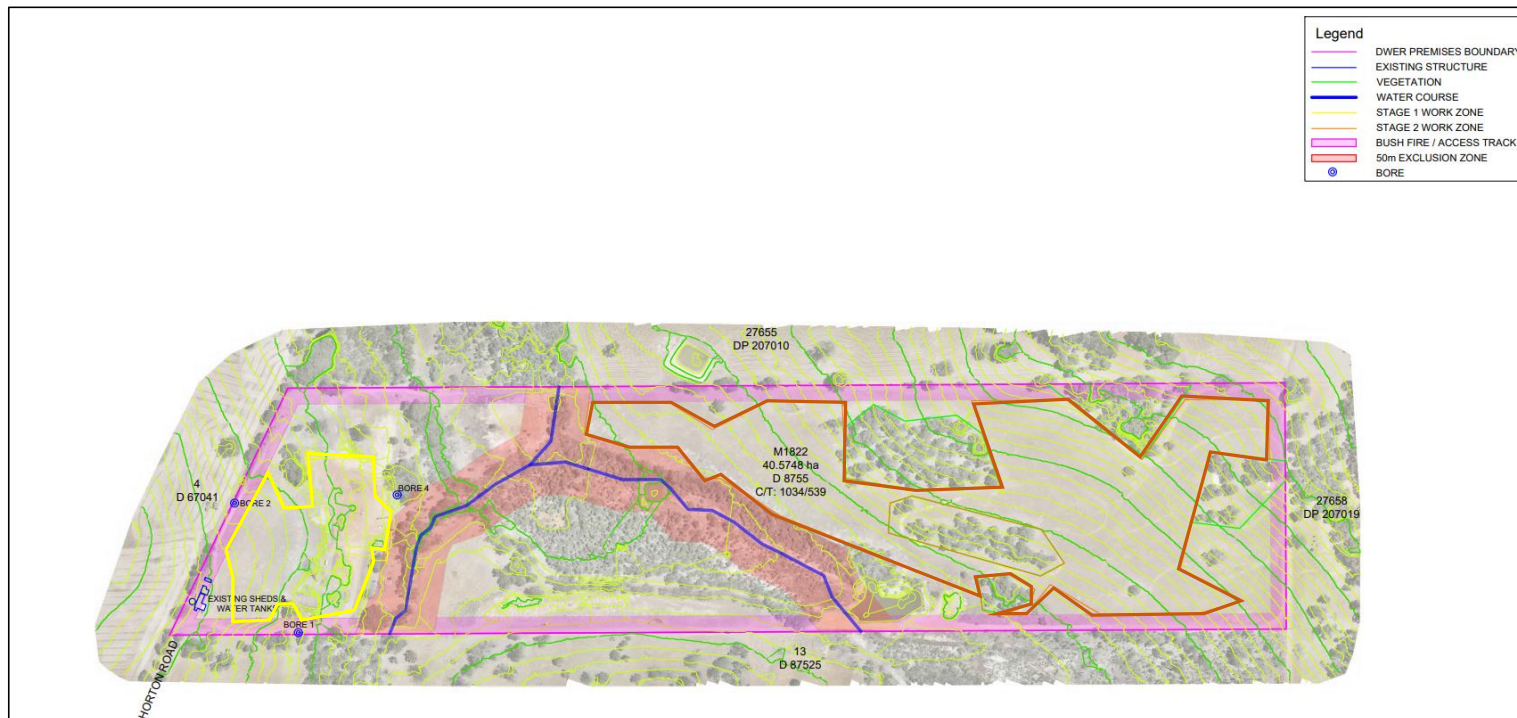

Figure 3: Boundary and watercourse setbacks

2 Environmental Policy

Capital Recycling is committed to continuous improvement in our business operations in order to protect the environment, in accordance with the requirements of the law, our clients, and expectations of the general community.

In applying this Policy, Capital Recycling's activities shall be controlled by the following principles:

- Capital Recycling shall abide by all relevant laws, Acts, Regulations and Standards.
- Capital Recycling shall plan, develop, implement and monitor relevant procedures and standards to minimise any unfavourable environmental impact that may result from our business activities.
- Capital is committed to working towards and aligning our business management systems with the ISO: 14001.2004 Standards for best practice Environmental Management.
- Capital Recycling employees shall be encouraged to develop a sense of responsibility for the protection of the environment.
- Capital Recycling will ensure that our employees are informed of our policy and are aware of their environmental responsibilities in relation to the Capital Recycling's business activities.

3 Overview of Site Characteristics

3.1 Location

The site is located on Lot M1822, 366 Horton Road, Woottating and located in the Shire of Northam (Figure 4). The Premises is approximately 55 kms east of Perth and access to the site is serviced by the Great Eastern Highway (major road) via the private Carter Road, via agreed private access between Capital Recycling and the land holder.

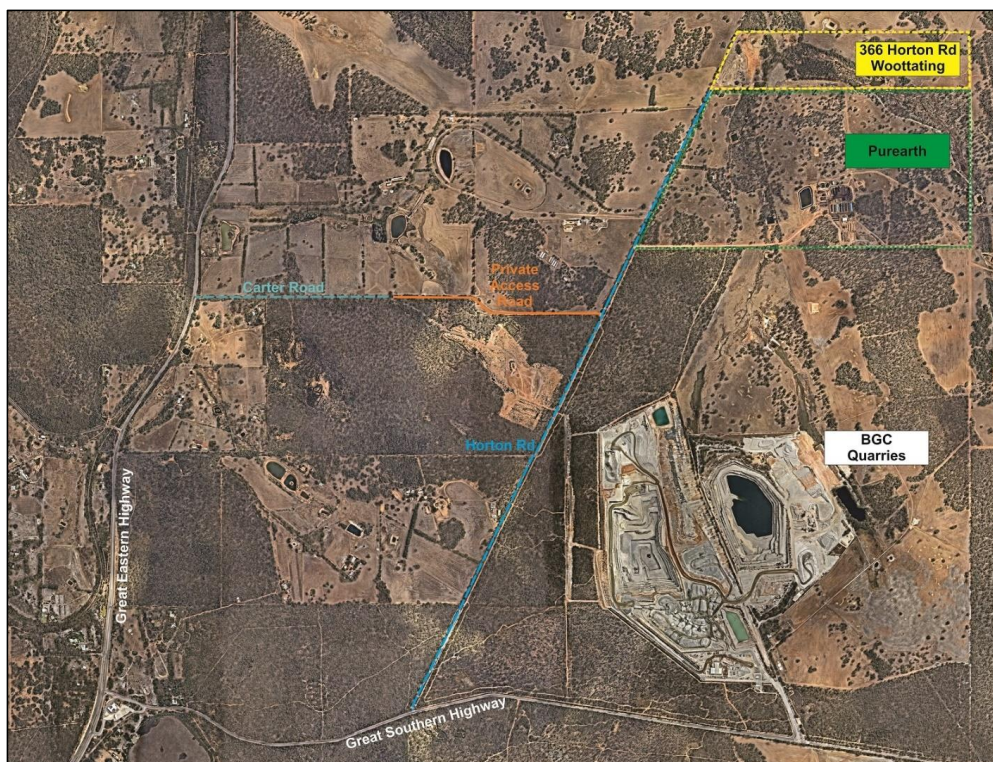

Figure 4: 366 Horton Road site location map

3.2 Receptors

The site is predominantly surrounded by rural properties used for cropping, sheep or cattle grazing with the closest residential receptor 830 m south west of the site, refer Table 2 and Figure 5.

Table 2: Receptors to the Premises

Receptors	Description	Proximity to Premises
Sensitive residential receptors	Auburn Park Residences and rural property off Gt Eastern Hwy used for grazing and crops	Approx. 830 m south-west of the Premises boundary
	Residence on rural property at 598 Warlin Road	Approx. 2.5 km south-east of the Premises boundary
	Residence on rural property at 284 Warlin Road	Approx. 945 north-east of the Premises boundary
Industrial premises	Pure Earth Composting Facility. Composting facility licenced for Category 61 and 67A	Approx. 600 m south-east of the Premises boundary
	Voyager II Quarry (BGC)	Approx. 1100 m south-west of the Premises boundary
Watercourse	Minor non-perennial watercourse flowing northward through the Premises	Located within the Premises
Groundwater	Present as a seasonal perched unit above the pallid clay zone of the laterite profile. The thickness of the perched aquifer, when present, is expected to range between <1 to 3 m	Depth to the regional groundwater table is approx. 20 – 25 mbgl.
DBCA managed land and waters	Keaginine Nature Reserve	Approximately 3.3 km north of the Premises boundary

DBCA-Department of Biodiversity, Conservation and Attractions

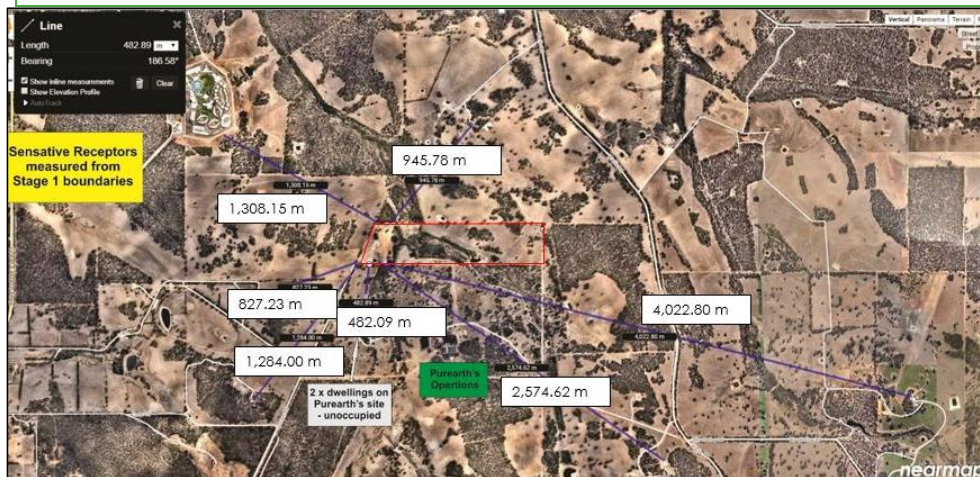

Figure 5: Receptors in a 5 kms radius to the Premises boundary

The 'Guidance for Assessment of Environmental Factors: Separation Distances between Industrial and Sensitive Land Uses No.3' (EPA, 2005) has not yet been updated to reflect the Environmental Protection Authority's (EPA) revised policy framework. In the interim of content being update, Appendix A of the Guidance states that buffer distances for "Extractive industries – no blasting conducted" is to be assessed on a case-by-case basis.

With respect to separation distances, impacts to potential receptors will be mitigated as:

- The closest sensitive residential receptor is located more than 800 m from the south west boundary with vegetation in between to act as a buffer for noise
- Highly putrescible and potentially odorous waste are not being accepted to site
- Operations are not conducted within 20 m of the boundary (particularly the south-west boundary)
- Environmental emission mitigation and management measures detailed in Sections 4 to 10 are implemented on site including monitoring of dust and noise during extraction campaigns
- The DWER Category 12 licence, Stages 1 and 2 EILs allow for extraction and screening of up to 55,000 tonnes per annum. Note that operations are undertaken on a staged approach i.e. 55,000 tonnes is unlikely to be extracted in any one year mitigating potential emissions from operations.

3.3 Climatic Conditions

The climatic conditions have been reviewed based on data from the Bureau of Meteorology Bakers Hill weather station, accessed in December 2022. Discussion with Capital Recycling General Manager from observation on site indicates that winds are predominantly east to south-east in the mornings switching to south-west in the afternoons. In cooler months, winds tend to come from westerly or northerly directions.

Figure 6 shows the mean 9am wind speed for the area with most recent data available from 1965 to 1985. The mean wind speed does not reach strong wind conditions on the Beaufort Scale² in January and February (when averaged). Average mean wind speeds for all other month's record light or moderate wind conditions.

The mean rainfall, from data from years 1964 to 2019 is shows that rainfall is higher over the months May to August with the highest levels being in July. Capital Recycling may not undertake excavation operational activities in June to August when rainfall is higher. Other operational activities could be undertaken, however, it is noted that in winter month screening can be impacted by wet conditions (e.g. screens 'clogging'). Consequently, it is likely that screening activity will be limited during winter months from an operational efficiency perspective.

² Beaufort wind scale, available: <http://www.bom.gov.au/marine/knowledge-centre/reference/wind.shtml>, accessed April 2020

Statistics	Jan	Feb	Mar	Apr	May	Jun	Jul	Aug	Sep	Oct	Nov	Dec	Annual	Years
Temperature														
Mean maximum temperature (°C)	31.8	31.7	28.5	23.5	19.2	16.0	15.1	15.6	17.5	21.7	25.6	29.9	23.0	21
Mean minimum temperature (°C)	15.7	16.1	14.6	12.3	9.4	7.6	6.6	6.4	7.0	8.9	11.2	14.0	10.8	20
Rainfall														
Mean rainfall (mm)	20.5	15.6	18.8	30.3	69.1	102.8	110.4	88.7	62.2	33.4	19.8	11.3	597.2	38
Decile 5 (median) rainfall (mm)	3.6	6.1	12.4	27.3	63.1	100.8	102.7	85.7	58.5	31.9	13.3	5.4	593.4	52
Mean number of days of rain ≥ 1 mm	1.6	1.6	1.9	4.2	7.3	10.2	11.1	10.2	8.2	4.9	3.1	1.8	66.1	52
Other daily elements														
Mean daily sunshine (hours)	11.1	10.0	9.2	7.1	6.2	5.0	5.4	6.4	7.3	9.0	10.0	10.9	8.1	20
Mean number of clear days														
Mean number of cloudy days														
9 am conditions														
Mean 9am temperature (°C)	22.5	22.1	20.0	16.7	13.4	11.1	10.0	10.5	12.3	15.4	18.4	21.5	16.2	21
Mean 9am relative humidity (%)	57	61	63	71	79	85	86	85	79	69	63	57	71	14
Mean 9am wind speed (km/h)	20.1	20.9	19.1	14.7	12.1	10.6	10.8	13.0	15.6	18.3	19.4	18.0	16.0	20

Figure 6: Average wind speed and rainfall for site locality

3.4 Geology & Hydrology

The site is located on lateritic gravelly soils of the Darling Plateau. The geology of the area was mapped by Smurthwaite (1987) for the Geological Survey of Western Australia and is recorded as being underlain by granite and laterite deposit entering from the south west boundary.

The site is characterised by two geomorphological classifications, a narrow, shallow valley floor of fluvial origin and a surface of planation and lateritic uplands of denudational origins. (Reference: Gozzard, J.R., 1989. and Smurthwaite, A. J. 1987).

The site is raised at the west and east boundaries with a valley running approximately south to north through the lot 300 m away from the western boundary. The elevation of the south western and north western corners of the Lot are 290 m and 280 m Australian Height Datum (AHD) respectively. The south eastern and north eastern corners have elevations of 290 m and 305 m AHD respectively.

The site consists of lateritic gravelly soils of the Darling Plateau. Underlying this layer is granite and laterite deposits. The site also contains a narrow shallow valley floor of fluvial origin and a surface of planation and lateritic uplands of denudational origins. The small creek bed contained within the lot is a minor non-perennial waterbody and is called Wooroloo Brook. There is evidence of perched water below the surface, and above the underlying granitic rock throughout the site. The perched water table drains into the watercourse running through the site.

The DWER Public drinking water source area mapping tool (PDWSA) was reviewed for the site. Accordingly, the site is not located within a public drinking water source and the nearest PDSWA is located over 3 kms to the south with P1 and P2 protection areas³.

³ PDSWA reviewed in: <https://www.water.wa.gov.au/maps-and-data/maps/public-drinking-water-source-area-mapping-tool>, accessed 07/04/20

4 Dust Management Plan

4.1 Potential Emissions

Dust emissions may arise from the extraction of gravel, block making activities and bulk product sales as outlined in Figure 7. Note: potential only for these emissions to occur and measures in place to mitigate.

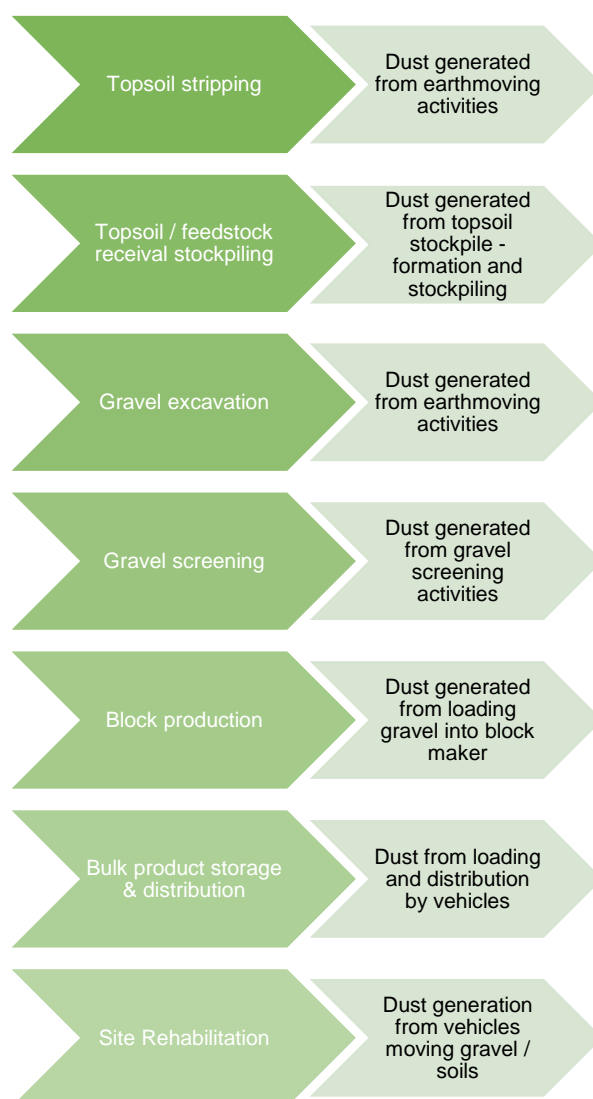

Figure 7: Potential dust emissions from gravel pit operations

4.2 Risk Assessment

The potential impact on residential receptors is expected to be low given that the closest residence is 830 m from the Premises south-west boundary and winds are generally light to moderate across the site. Though afternoon winds in summer months can tend towards south-westerly, operational activities for gravel extraction will be conducted on a campaign basis (i.e. not continuous) and screening activities will not be undertaken in any periods of strong winds (>25 knots) towards the direction of the closest receptor.

A review of the risk assessment of Category 12, EIL and block making activities was undertaken in accordance with 'A guideline for managing the impacts of dust and associated contaminants from land development sites, contaminated sites remediation and other related activities'⁴ and changes to receptors in proximity to the Premises. Proximity to neighbouring residential receptors is detailed in section 3.2.

The Pure Earth Composting Facility located at approximately 600 m south of the Premises has been operating since 2013. The risk assessment takes into account potential cumulative emissions from grinding / screening activities at the Pure Earth site. Note that the Pure Earth Composting Facility will most likely have submitted a Dust Management Plan to DWER for their licence application outlining management measures to mitigate offsite dust migration; reducing the potential for cumulative emissions.

The risk assessment has been conducted on operational activities that could generate dust emissions and reviewed against the Guideline Addendum⁵.

Table 3: Part A - Nature of the site

Item	Score		Assessment
	Option	Score	
1. Nuisance potential of gravel / soil when disturbed	Medium	4	<ul style="list-style-type: none"> - Stripping of topsoil and potential for migration of dust particles across Premises boundary - Excavation of gravel and potential for gravel and clay particles to become airborne and migrate beyond Premises boundary - Layering of topsoil on surface and potential for dust migration from sandy soil particles - Stockpiling of feedstocks for screening activities - Screening activities - Loading of gravel into block making equipment - Stockpiling of bulk products for distribution to markets - Stockpiling of topsoil for rehabilitation purpose and potential for windblown particles - Infilling of excavated area with soil and potential for dust generation from soil particles
2. Topography and protection provided by undisturbed vegetation	Little screening	12	<ul style="list-style-type: none"> - Undulating site with patches of vegetation between the Premises and sensitive residential receptors (located approx. 830 m away)

⁴ Available: https://www.der.wa.gov.au/images/documents/your-environment/air/publications/Guideline_for_managing_impacts_of_dust.pdf, accessed April 2020

⁵ Available: https://www.der.wa.gov.au/images/documents/your-environment/air/publications/Guideline_for_managing_impacts_of_dust.pdf, accessed April 2020

Item	Score		Assessment
	Option	Score	
3. Area of site distributed by works	Between 1 and 5 ha	3	<ul style="list-style-type: none"> - Excavations will be on a campaign basis lasting about 3-4 weeks - Where practicable, site works and any rehabilitation will occur progressively
4. Type of work being done	Bulk earthworks and deep trench	9	<ul style="list-style-type: none"> - Gravel extraction will occur at depths between 1 m and 4 m, generally averaging 2.5 m - Excavations of Stage 1 and 2 show that excavations can range from 1 m, with limited excavations (to date) at 4 m
Score total		28	

Table 4: Part B – Proximity of site to other land uses

Item	Score		Assessment
	Option	Score	
1. Distance to other land uses from site	Between 1 km and 500 m	6	<ul style="list-style-type: none"> - Closest residential receptor 830 m south-west of the Premises boundary - Pure Earth Composting Facility 600 m south-east of the Premises boundary
2. Effect of prevailing wind direction on other land uses	Isolated land uses affected by one wind direction	6	<ul style="list-style-type: none"> - Winds are predominantly east to south-east in the mornings switching to south-west in the afternoons. In cooler months, winds tend to come from westerly or northerly directions. Dust emissions will be mitigated by management practices and operational activities including limiting of activities in strong winds (>25 knots) - Pure Earth Composting Facility is located approximately 600 m from the Premises boundary. Potential cumulative dust emission will be mitigated by management practices and operational activities outlined in section 4.4. It is assumed that Dust Management Plan and management actions are in place at Pure Earth - Gravel extracted on a campaign basis not continuously
Total score		12	

The Premises risk assessment for operational activities generating dust is rated as 'Classification 2 – considered low risk'. The final Score (Part A x Part B) is 336. Dust management objectives and management of potential impacts have been drawn up for operational activities to mitigate any emission potential with this low-risk classification.

4.3 Objectives

The objectives of the Dust Management Plan are to:

- Take all reasonable and practicable measures to ensure the prevention of dust from the Premises
- Comply with limits set by the National Environment Protection (Ambient Air Quality) Measure (NEPC, 1998)
- Ensure that nuisance dust levels and potential health hazards are not experienced by operational staff
- Ensure that nuisance dust levels and potential health hazards are not experience by neighbouring residential receptors.

4.4 Management of potential dust emissions

The following sub-sections outline mitigation activities to be undertaken for particular operational activities.

4.4.1 Site management

- Site personnel will undertake a site-specific induction including use of Personal Protective Equipment (PPE) to prevent health hazards and exposure to dust emissions. Generally, one or two Capital employees on site when site is operational
- Where practicable topsoil stripping, gravel excavation, screening and rehabilitation activities will not be undertaken in periods of strong winds
- The Site Supervisor will monitor wind conditions daily using weather app (e.g. Willy Weather) to assess wind strength and direction. In the event of strong winds (>25 Knots) and in particular in the direction of the closest sensitive receptor, scheduling of operations with reduced potential for dust generation will be assessed. The scheduling of operations may include measures to cease excavation and screening activities in the event of extreme adverse weather conditions
- Where practicable with operational requirements, excavated areas will be progressively rehabilitated, to reduce the potential for windborne dust generation
- Truck mounted sprays will water unsealed, regularly trafficked areas such as access tracks, work areas and haul roads as conditions require
- Routine housekeeping practices will be employed to ensure that spillages and other materials that could contribute to dust generation do not accumulate within the Premises boundary
- Routine maintenance of machinery will be carried out to ensure efficient operation (to minimise exhaust particulate emissions)
- In the event that dust migrates beyond the Premises boundary, dust suppression measures will be immediately reviewed to ensure practices are being followed and / or to implement more stringent measures. Such measures could include the cessation of activities in the event of extreme adverse weather conditions
- All personnel (including contractors) will be informed of their responsibilities and the importance of minimising ambient dust levels during site inductions
- Any complaints received will be registered on the 'Environmental Complaints Register' and will trigger a review of the relevant dust management measures by the Site Supervisor as a basis for continual improvement and implementation of appropriate modified practice/s (Refer to Section 10 for a copy of the Complaints Register Form).

4.4.2 Management by Operational Activity

Table 5 sets out the dust management for operational activities.

Table 5: Dust management for Operational Activities

Operational activity	Proposed controls	Responsibility
Stripping of topsoil	<ul style="list-style-type: none"> - Where practicable, topsoil stripping not to be undertaken in strong wind conditions (> 25 knots) - Monitor wind conditions in times of strong prevailing winds (>25 knots) in direction of closest sensitive receptors, and modify topsoil operations accordingly to mitigate dust generation (i.e. cease or limit operations, wet down working area) - Water truck will be stationed on site and used, in dry conditions and strong winds, for wetting down during topsoil stripping - Operator to monitor dust generation and potential for migration 	Site Supervisor / Operator
Soil stockpiling	<ul style="list-style-type: none"> - Stockpiles to be maintained at <7 m high - In dry weather and strong wind conditions (>25 knots), stockpiles to be watered down to prevent dust generation during operational activities - Newly created stockpiles will be wet down prior to the end of each day's operating activities - Speed limit of <15 kms to be implemented on internal roads to minimise dust - Operator to monitor dust generation and potential for migration 	Site Supervisor / Operator
Gravel extraction	<ul style="list-style-type: none"> - Where practicable, gravel extraction not to be undertaken in strong wind conditions (> 25 knots) - Monitor wind conditions in times of strong prevailing winds (>25 knots) in direction of closest sensitive receptors, and modify excavation operations accordingly to mitigate dust generation (i.e. cease or limit operations, wet down working area) - Water truck will be stationed on site and used, in dry conditions and strong winds, for wetting down during excavation activities - Maintain a minimum working area - Operator to monitor dust generation and potential for migration 	Site Supervisor / Operator

Operational activity	Proposed controls	Responsibility
Screening	<ul style="list-style-type: none"> - Where practicable, screening not to be undertaken in strong wind conditions (> 25 knots) - Monitor wind conditions in times of strong prevailing winds (>25 knots) in direction of closest sensitive receptors, and modify excavation operations accordingly to mitigate dust generation (i.e. cease or limit operations, wet down working area) - Water truck will be stationed on site and used, in dry conditions and strong winds, for wetting down during excavation activities - Maintain a minimum working area - Operator to monitor dust generation and potential for migration - Gravel screening and soil blending processes will not occur at the same time, mitigating dust generation 	Site Supervisor / Operator
Bulk product stockpiling	<ul style="list-style-type: none"> - Stockpiles to be maintained at <7 m high - In dry weather and strong wind conditions (>30 knots), stockpiles to be watered down to prevent dust generation during operational activities - Newly created stockpiles will be wet down prior to the end of each days operating activities - Speed limit of <15 kms to be implemented on internal roads to minimise dust - Operator to monitor dust generation and potential for migration 	Site Supervisor / Operator
Loading of gravel for block making	<ul style="list-style-type: none"> - Stockpiles to be maintained at <7 m high - In dry weather and strong wind conditions (>25 knots), stockpiles to be watered down to prevent dust generation during operational activities - Care will be taken in loading gravel into hopper so as to mitigate any plumes of dust generation 	
Distribution of products from site	<ul style="list-style-type: none"> - Use of dust cart to wet down access roads in dry conditions - Operator to proactively monitor visible dust not cross the boundary premises 	Site Supervisor / Operator
	<ul style="list-style-type: none"> - Haulage vehicles to cover loads when transporting to and from site 	Vehicle operator / Contractor
Transport of soil to site for rehabilitation	<ul style="list-style-type: none"> - Use of water truck to wet down access road in dry conditions - Site supervisor to proactively monitor visible dust does not cross the boundary premises 	Site Supervisor / Operator

4.5 Monitoring

Monitoring (when operating) will entail visual assessment by the Site Supervisor of both atmospheric levels of dust and dust deposition on surrounding sporadic vegetation. The aim of visual assessment is to identify any times of the day that wind conditions may impact more readily on dust emissions potentially migrating off site and evaluate dust management strategies for effectiveness and continual improvement (in line with Capital's Environmental Policy to work towards aligning site practices with ISO 14001). The Site Supervisor will undertake visual monitoring using the work instruction form.

Dust emission monitoring will be the responsibility of the Site Supervisor. On a periodic basis and to verify visual assessment and mitigate the effectiveness of any desensitising of dust emissions by the Site Supervisor, the General Manager may conduct dust emission monitoring (if required).

A sample copy of the proposed dust and noise monitoring work instruction is provided here.



19 Felspar Street
Welshpool WA 6106
Ph: (08) 9279 4599
www.capitalrecycling.com.au

info@capitalperth.com.au
ar@capitalperth.com.au (Accounts)

Capital Dust and Noise Monitoring
To be completed by the Site Supervisor

Date:	2/3/2020	Supervisor:	Ian White
Weather conditions:	Sunny, Light winds	Wind direction / strength:	SW 10km/h
Stage:	1	Working area:	Eastern side - centre
Today's activities	Extraction Loading Trucks	People on site:	2
Equipment in use:	Excavator Wheel Loader Water truck	Trucks:	2 on turn around
Dust control duties:	Ben Mitchell	Tanks used:	4

Boundary Check for Assessment – All equipment operational					
Dust			Noise		
South Boundary	I	A		I	A
West Boundary	I	A		I	A
North Boundary	I	A		P	A
East Boundary	I	A		P	A

Intensity Scale	A = Acceptable E = Excessive	Extent Classification	I = Intermittent P = Persistent
Comments:	No issues	Signed:	Ian White
Start time:	7.15am	Completion time:	3.30pm

Fairfield Holdings Pty Ltd ATF T R Gulotto FM TST T-AS | ACN 104088320 | ABN 44 603 482 405

5 Noise Management

5.1 Potential Emissions

Potential noise emissions that may arise from the extraction of gravel, block making activities and bulk product sales as outlined in Figure 8. Note: potential only for these emissions to occur and measures in place to mitigate.

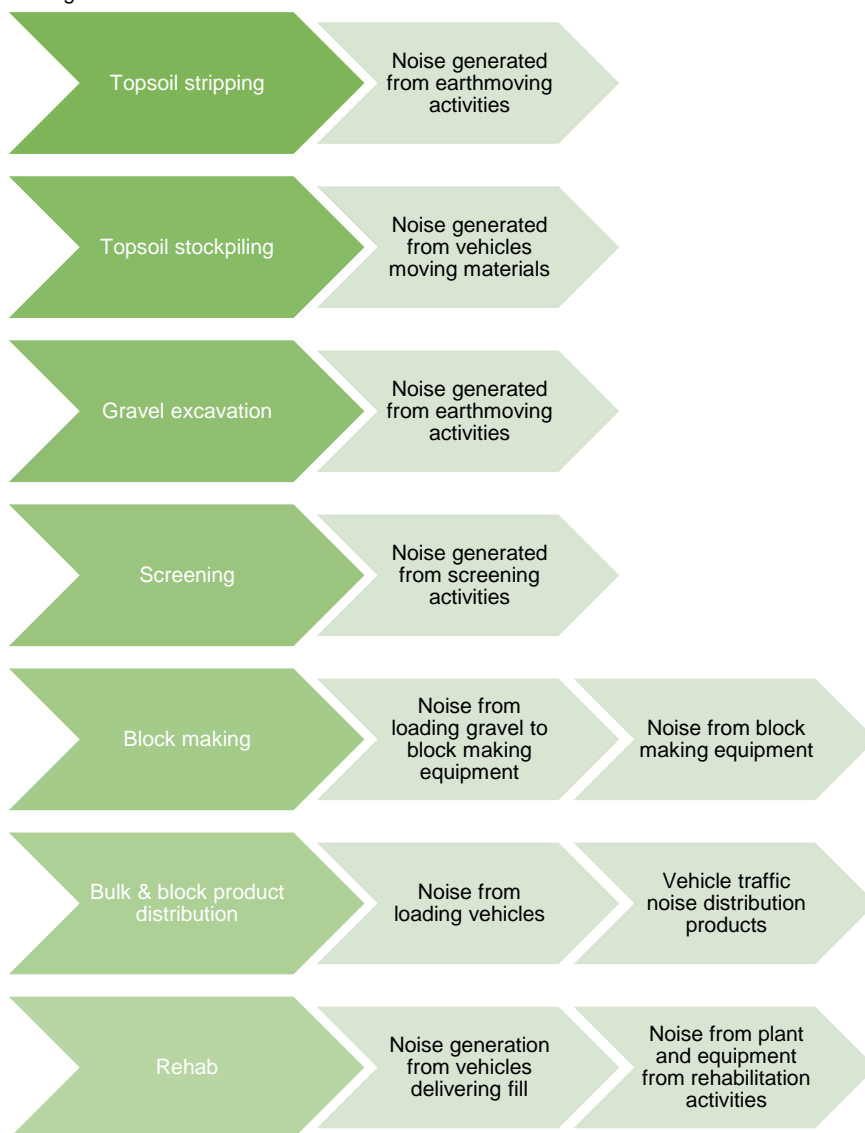

Figure 8: Activities generating noise

5.2 Risk Assessment

The potential noise impacts on residential receptors are expected to be mitigated given that:

- The closest residence is approx. 830 m south-west from the Premises boundary
- Operations will occur at least at a distance of 20 m within the boundary with block making activities located more than 20 m inside the boundary
- Operational activities for gravel extraction are undertaken on a campaign not continuous basis, over 3 to 4 weeks
- Rehabilitation for will occur on a progressive basis where practicable
- Noise reduction measures on plant and equipment have been fitted including “croakers” not “beepers” on loaders
- Operations will occur between 7am and 7pm (in line with Noise Regulations).

A review of the risk assessment of Category 12 DWER licence, EIL and block making activities has been undertaken in accordance with the Environmental Protection (Noise) Regulations 1997 (As Amended)⁶.

A noise impact assessment was undertaken in 2008 by the previous land owner for a (then) proposed development of a composting facility (VIPAC, 2009). This noise assessment was undertaken on the following equipment:

- excavator
- loader
- grader
- screening equipment
- truck movements

Note that the similar equipment is currently in use at the site for the gravel extraction operations. The results from the noise impact assessment are reproduced in Table 6.

Table 6: Extract from VIPAC and Bowman (2013) noise impact assessment

Activity /Site Operation	Predicted Noise level, dB (A)	Day – time Noise Criteria, dB (A)	Assessment
Volvo Loader	44	45	Criteria Achieved
Truck loading	24		Criteria Achieved
Mulcher	36		Criteria Achieved
A digger/excavator	33		Criteria Achieved
Screening plant	44		Criteria Achieved

⁶ Available: <https://www.der.wa.gov.au/your-environment/noise>, accessed April 2020

It is noted that whilst the noise assessment criterion was achieved, the assessment was conducted 2008, there have been changes to the location of residential receptors being located further away and Capital Recycling propose to purchase a block making machine and produce blocks for distribution to the construction sector.

In assessing the potential noise emissions and risk, the following aspects are highlighted:

- The VIPAC Report (2009) assessed the impact on a residential receptor which was then located at 132 Warlin Road⁷ and approximately 530 m south of the Premises boundary. Since the time of the noise assessment in 2009, this site has been bought by Pure Earth Composting and the residences located 530 m south are unoccupied
- The closest residential receptor is now located approximately 830 m south west of the Premises boundary, thus allowing for greater separation distance from site operational activities
- Gravel extraction activities will take place a minimum of 20 m from the Premises boundary and as for dust monitoring, monitoring of climatic conditions will be undertaken to mitigate potential noise impacts on the closest sensitive receptor in the event of strong wind conditions (>25 knots)
- Operations will occur on a campaign not continuous basis, for 3 to 4 weeks each campaign
- Operational activities will be limited to 7am and 7pm in line with Noise Regulations including 'start up', 'shut down' and maintenance activities
- Loaders are fitted with reversing "croakers" (not beepers)
- The Pure Earth Composting Facility located at approximately 600 m has been operating since 2013 and will most likely have submitted a Noise Management Plan to DWER for their licence application outlining management measures to mitigate noise generation; reducing the potential cumulative impacts of the two sites.

5.2.1 Block making machine

Capital Recycling are to purchase a pre-owned Finlay F44 block making machine. Note the maximum hopper capacity is 2.5m³ and the machine does not occupy a large footprint at about 10m². The block making machine is not a significant piece of equipment with large throughput volumes.

Predicted noise levels around the machine up to 1 m are 96 dB⁸ with levels dissipating beyond this. It is not expected that the block making machine would significantly contribute to cumulative noise levels from the site.

Figure 9: Noise levels at 1 m around block making machine

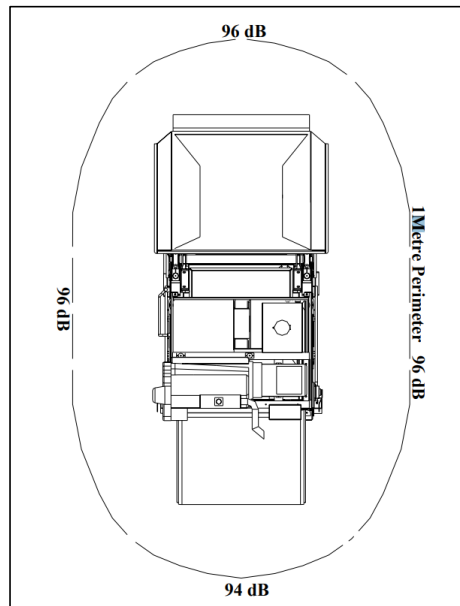

⁷ Note in the VIPAC (2009) report the name of the road is misspelt and that Lot 13 refers to Lot M1822 (assumption of Lot number changes as a result of transfer of land ownerships / subdivisions)

⁸ Refer Attachment A-Finlay F44 specs

5.3 Objectives

The objectives of the Noise Management Plan are to:

- Take all reasonable and practicable measures to minimise noise generation from operations
- Comply with limits set by the Environmental Protection (Noise) Regulations 1997 (As Amended).

5.4 Management of potential noise emissions

The following sub-sections outline mitigation activities to be undertaken for particular operational activities.

5.4.1 Site management

- Site personnel will undertake a site-specific induction including use of PPE to prevent health hazards and exposure to noise emissions
- Where practicable topsoil stripping, gravel excavation and rehabilitation activities will be undertaken in periods of calm or light winds to reduce noise migration (in particular in the direction of the closest residential receptor)
- The Site Supervisor will monitor wind conditions daily using a weather app to assess wind strength and direction. In the event of strong winds (>25 Knots) and in particular in the direction of the closest sensitive receptor, scheduling of operations with reduced potential for noise generation will be assessed. The scheduling of operations may include measures to alternate excavation and screening activities to reduce overall noise generation from the Premises
- Where practicable with operational requirements, excavated areas will be progressively rehabilitated, to reduce the potential for noise generation
- All plant (e.g. loaders) will be fitted with “croakers” to reduce high-pitched noise migration
- Screening activities will be located inside 20 m of the Premises boundary
- Routine maintenance of machinery will be carried out to ensure efficient operation
- All personnel will be informed of their responsibilities and the importance of minimising noise levels during site inductions
- Any complaints received will be registered on the ‘Environmental Complaints Register’ and will trigger a review of the relevant noise management measures by the Site Supervisor as a basis for development and implementation of appropriate modified practice/s. This may include undertaking of noise impact assessment by Capital Recycling in the unlikely event of sustained complaints from receptors within the proximity.

5.4.2 Management by Operational Activity

Table 7 sets out the noise management for operational activities.

Table 7: Noise management for Operational Activities

Operational activity	Proposed controls	Responsibility
Stripping of topsoil	<ul style="list-style-type: none"> - Site operational activities will be conducted between 7am and 7pm - Plant and equipment will be regularly maintained - "Croakers" as opposed to beepers will be fitted to mobile plant including loaders - Operator to monitor noise generation and potential for migration 	Site Supervisor
Topsoil stockpiling	<ul style="list-style-type: none"> - Site operational activities will be conducted between 7am and 7pm - Plant and equipment will be regularly maintained - "Croakers" as opposed to beepers will be fitted to mobile plant including loaders - Speed limit of <15 kms to be implemented on internal roads to minimize noise 	Site Supervisor / Operator
Gravel extraction	<ul style="list-style-type: none"> - Where practicable, gravel extraction to be confined to calm / light wind conditions - Monitor wind conditions in times of strong prevailing winds (>25 knots) in direction of closest sensitive receptors, and modify excavation operations accordingly (i.e. limit operations) - Site operational activities will be conducted between 7am and 7pm - Plant and equipment will be regularly maintained - "Croakers" as opposed to beepers will be fitted to mobile plant including loaders - Site supervisor to proactively monitor audible noise at the Premises boundary, especially in the event of all activities on site occurring (i.e. topsoil stripping / stockpiling, gravel extraction, screening and rehabilitation) - Maintain a minimum working area 	Site Supervisor / Operator

Operational activity	Proposed controls	Responsibility
Screening	<ul style="list-style-type: none"> - Where practicable, screening to be confined to calm / light wind conditions - Monitor wind conditions in times of strong prevailing winds (>25 knots) in direction of closest sensitive receptors, and modify excavation operations accordingly to mitigate noise generation (i.e. limit operations) - Site supervisor to proactively monitor audible noise at the Premises boundary, especially in the event of all activities on site occurring (i.e. topsoil stripping / stockpiling, gravel extraction, screening and rehabilitation) - Site operational activities will be conducted between 7am and 7pm - Plant and equipment will be regularly maintained - "Croakers" as opposed to beepers will be fitted to mobile plant including loaders - Maintain a minimum working area 	Site Supervisor / Operator
Block making	<ul style="list-style-type: none"> - Block making will be conducted between 7am and 5pm - Machine to be located on the hardstand area located well within the Premises boundary - Machine to be regularly maintained - Care to be taken when loading hopper to minimise noise - Operator to monitor noise generation and potential for 	Site Supervisor / Operator
Product stockpiling	<ul style="list-style-type: none"> - Site operational activities will be conducted between 7am and 7pm - Plant and equipment will be regularly maintained - "Croakers" as opposed to beepers will be fitted to mobile plant including loaders - Speed limit of <15 kms to be implemented on internal roads to minimise vehicle noise 	Site Supervisor / Operator
Rehabilitation activities	<ul style="list-style-type: none"> - Where practicable, screening to be confined to calm / light wind conditions - Where practicable, rehabilitation to occur progressively in working areas - Monitor wind conditions in times of strong prevailing winds (>25 knots) in direction of closest sensitive receptors, and modify excavation operations accordingly to mitigate noise generation (i.e. limit operations) - Site supervisor to proactively monitor audible noise at the Premises boundary, especially in the event of all activities on site occurring (i.e. topsoil stripping / stockpiling, gravel extraction, screening and rehabilitation) - Site operational activities will be conducted between 7am and 7pm - Plant and equipment will be regularly maintained - "Croakers" as opposed to beepers will be fitted to mobile plant including loaders 	Site Supervisor / Operator

Operational activity	Proposed controls	Responsibility
Distribution of products from site	<ul style="list-style-type: none"> - Distribution of products from site to occur between 7am and prior to 7pm - Product loads to be covered on distribution from site 	Site Supervisor / Operator
	<ul style="list-style-type: none"> - Speed limits to be adhered to on access roads. Capital Recycling and Pure Earth lease a 20 m wide section of land to provide a private access road to both Premises with a speed limit of 40 km on this road. Where the private road comes out on Horton Road is beyond any receptors and there are truck passing bays constructed. The remaining section of Horton Rd only gives direct access to Pure Earth and Capital. It also has a 40 km limit - Trucks are not to idle at Premises entry / exit areas 	Vehicle operator / Contractor
Transport of soil to site for rehabilitation	<ul style="list-style-type: none"> - Use of water truck to wet down access road in dry conditions - Site supervisor to proactively monitor visible dust crossing the boundary premises 	Vehicle operator / Contractor

5.5 Monitoring

Monitoring of noise at the boundary will be undertaken by the Site Supervisor using the work instruction sheet. In particular, monitoring will be undertaken when all plant and equipment is in use on site (i.e. for topsoil stripping / stockpiling, gravel extraction, screening and rehabilitation activities; or a combination thereof). The aim of on-site monitoring is to identify any times that activities may impact on noise generation and cumulative noise emissions, and evaluate noise management strategies for effectiveness and continual improvement (in line with Capital's Environmental Policy to work towards aligning site practices with ISO 14001).

Noise emission monitoring will be the responsibility of the Site Supervisor who will report to the General Manager. On a periodic basis and to verify monitoring and mitigate the effect of any desensitising to noise by the Site Supervisor, the General Manager will conduct noise emission monitoring.

A sample copy of the proposed dust and noise monitoring work instruction is provided below.



19 Felspar Street | Ph: (08) 9279 4599 | info@capitalperth.com.au
Welshpool WA 6106 | www.capitalrecycling.com.au | ar@capitalperth.com.au (Accounts)

Capital Dust and Noise Monitoring

To be completed by the Site Supervisor

Date:	2/3/2020		Supervisor:	Ian White	
Weather conditions:	Sunny, Light winds		Wind direction / strength:	SW 10km/h	
Stage:	1		Working area:	Eastern side - centre	
Today's activities	Extraction Loading Trucks		People on site:	2	
Equipment in use:	Excavator Wheel Loader Water truck		Trucks:	2 on turn around	
Dust control duties:	Ben Mitchell		Tanks used:	4	
Boundary Check for Assessment – All equipment operational					
	Dust			Noise	
South Boundary	I	A		I	A
West Boundary	I	A		I	A
North Boundary	I	A		P	A
East Boundary	I	A		P	A
Intensity Scale	A = Acceptable E = Excessive		Extent Classification	I = Intermittent P = Persistent	
Comments:	No issues		Signed:	Ian White	
Start time:	7.15am		Completion time:	3.30pm	

Page 1

6 Water Management

6.1 Potential Emissions

Potential noise emissions that may arise from the extraction of gravel, block making activities and bulk product sales as outlined in Figure 10. Note: potential only for these emissions to occur and measures in place to mitigate.

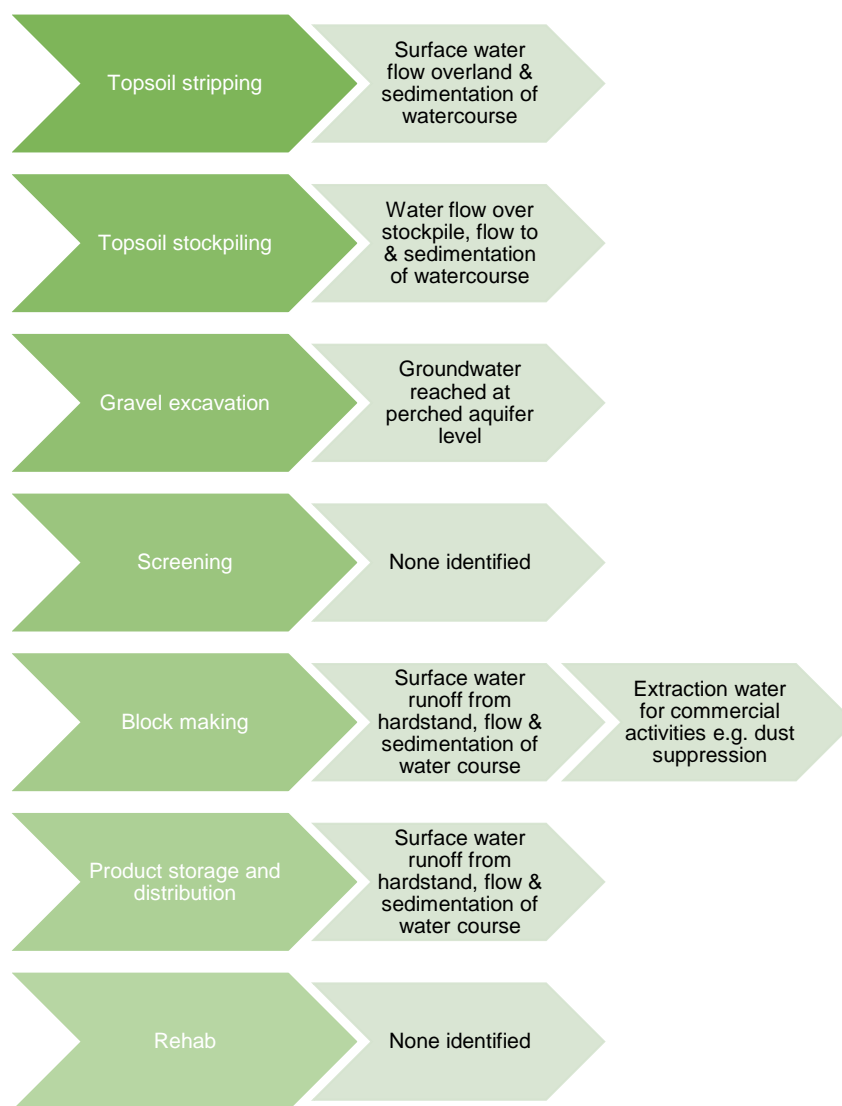

Figure 10: Potential emissions to surface / ground water from operations

6.2 Risk Assessment

In accordance with DWER Category 12 licence L9251, surface and groundwater monitoring are undertaken on bi-annual basis and Figure 1 shows the monitoring bores and surface monitoring locations. Sample analysis is undertaken by a National Association of Testing Authorities (NATA) laboratory for the parameters outlined in Table 8.

Sampling methods are conducted in accordance with AS/NZS 5667.4 and AS/NZS 5667.11 for surface and ground water sampling respectively.

Table 8: Surface and groundwater monitoring locations and parameters

Monitoring	Monitoring location	Parameter
Surface water	<ul style="list-style-type: none"> - Upstream location 1 and 2 - Downstream location 3 	<ul style="list-style-type: none"> - Turbidity (NTU) - pH (pH unit) - Electrical conductivity (uS/cm) - Total dissolved solids (mg/L) - Total nitrogen (mg/L) - Phosphorous (mg/L)
Groundwater	<ul style="list-style-type: none"> - MB1 - MB4 	<ul style="list-style-type: none"> - Standing water level (m AHD) - pH (pH unit) - Total dissolved solids (mg/L) - Total nitrogen (mg/L) - Phosphorous (mg/L)

The following guidelines have been used in the assessment and interpretation of sample analysis results:

- Table D1, Appendix D of 'Assessment and management of contaminated sites' (DWER, November 2021)⁹
- Section 2.3, Rivers & Streams of 'Australian water quality guidelines for fresh and marine waters' (ANZECC, 1992)¹⁰.

Analysis and review of the water monitoring results is submitted to DWER as part of licence conditions in the Annual Audit Compliance Report and Annual Environmental Report.

6.3 Objectives

- To monitor surface and groundwater quality in line with relevant DWER licence requirements
- To meet the requirements for use of water under relevant state water legislation¹¹.

⁹ Available: [Contaminated sites guidelines - Department of Water and Environmental Regulation \(der.wa.gov.au\)](https://www.der.wa.gov.au/publications/contaminated-sites-guidelines), Accessed: December 2022

¹⁰ Available: [Water Quality Guidelines ANZECC \(1992\) water quality guidelines](https://www.anzecc.org.au/water-quality-guidelines), Accessed: December 2022

¹¹ Available: https://www.legislation.wa.gov.au/legislation/statutes.nsf/main_mrtitle_844_homepage.html, Accessed: November 2022

6.4 Site characteristics, engineering & operational measures

6.4.1 Climatic and Site characteristics

There are natural site characteristics that serve to mitigate potential emissions to water and sedimentation of the watercourse including:

- High temperatures and observed high evaporation rates occur across the site during the summer months mitigating potential impacts of pooling of water from excavated areas, and possible runoff into the watercourse with any rainfall during summer months
- Ironstone gravel comprising good clay content that 'holds' water so it permeates slowly through to groundwater. Nitrogen and phosphate can adsorb to clay particles and be "bound" up in the soil/gravel.

6.4.2 Engineering and operational measures

To manage potential impacts to water from extraction and soil blending activities, the following engineering and management controls are in place:

- For block making operation, proposed construction of a 2,500 m² hardstand to undertake activities and store bulk and block products for distribution
- For the block making operation, proposed construction of two soaks have been designed to capture runoff from the hardstand (and any soil)
- Runoff water captured from the hardstand will be used for onsite operational activities including dust suppression
- Water will not be extracted from the water course and will be drawn from an onsite production bore for commercial activities
- Gravel excavation activities will be assessed and limited (if required) in periods of heavier rainfall, generally June to August, and therefore higher likelihood of runoff
- Screening and / or blending activities may not be undertaken in periods of heavier rainfall, generally June to August)
- The Site Supervisor will monitor rainfall conditions daily to assess potential inundation of gravel pits. In the event of heavy rainfall, scheduling of extraction activities will be assessed to mitigate any potential to impact higher (occasional) groundwater levels. The scheduling of operations may include measures to cease excavation in the event of extreme adverse weather conditions
- Where practicable with operational requirements, excavated areas will be progressively rehabilitated to reduce the potential for pits to become inundated (though there are observed high evaporation rates in the summer months)
- Routine housekeeping practices will be employed to ensure that spillages and other materials do not contribute to surface water pollution
- All personnel will be informed of their responsibilities and the importance of minimising any impacts to surface and groundwater.

7 Rehabilitation Plan

This rehabilitation plan has been prepared with input from research undertaken by the University of Western Australia on increasing knowledge of cropping on ironstone gravel soils¹².

7.1 Gravel Extraction Operations

Gravel extraction will be undertaken at the Premises (366 Horton Road) and the site rehabilitated with soil suitable for native vegetation and to ameliorate the gravel soils for use as a cropping medium.

The extraction of gravel will be undertaken in a staged approach. Figure 11 shows the Stage 1 and 2 gravel extraction areas. No vegetation will be cleared in either stage.

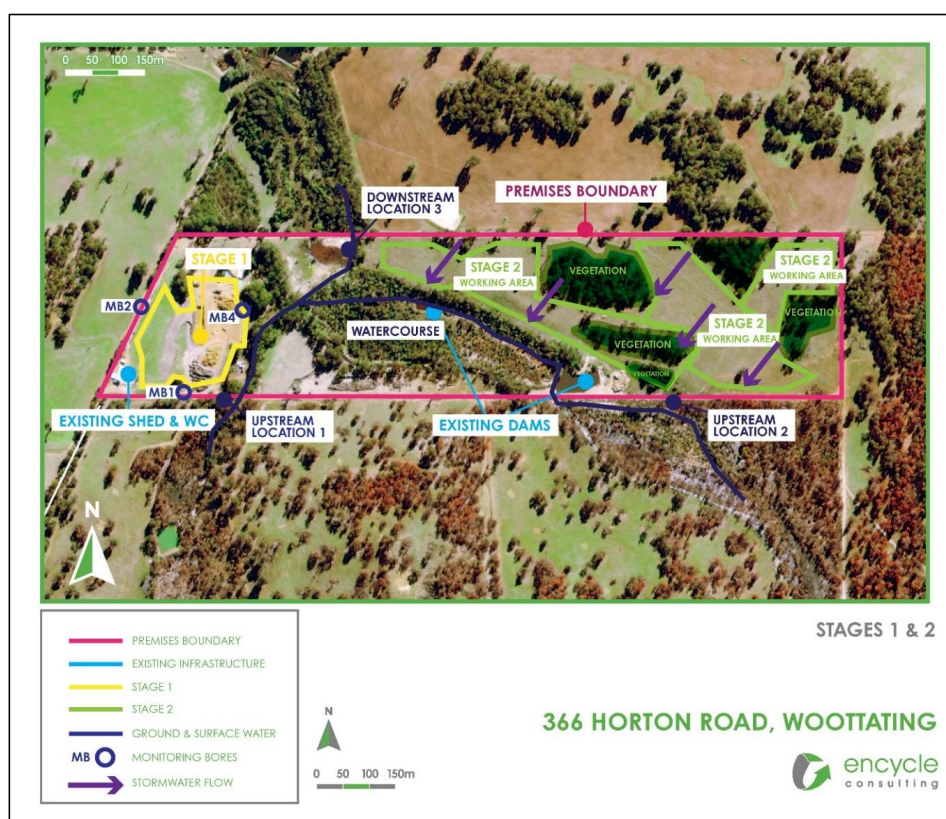

Figure 11: Stage 1 and Stage 2 gravel extraction areas

¹² Available: <https://research-repository.uwa.edu.au/en/projects/increasing-knowledge-and-profitability-of-cropping-on-ironstone-g>, Accessed: August 2022

7.1.1 Exclusion zones

Figure 12 shows the DWER prescribed premises boundary, 20 m exclusion area from the boundary, 40 m exclusion area west of the water course mid line, major and minor contour lines for Stage 1. Figure 13 shows the DWER prescribed premises boundary, 20 m exclusion area from the boundary, 40 m exclusion area east of the water course mid line, major and minor contour lines for Stage 2.

Note that the Shire Planning department has been provided with detailed surveyed maps for the site showing the major and minor contours as outlined in Figure 12 and Figure 13.

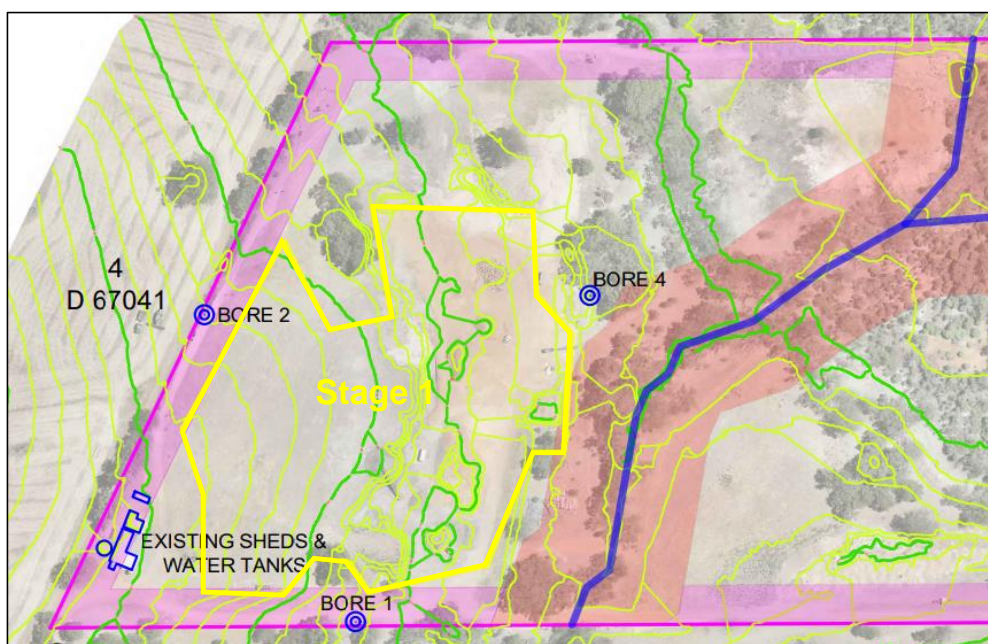

Figure 12: Stage 1 gravel extraction boundary exclusion areas (pink and red shaded areas)

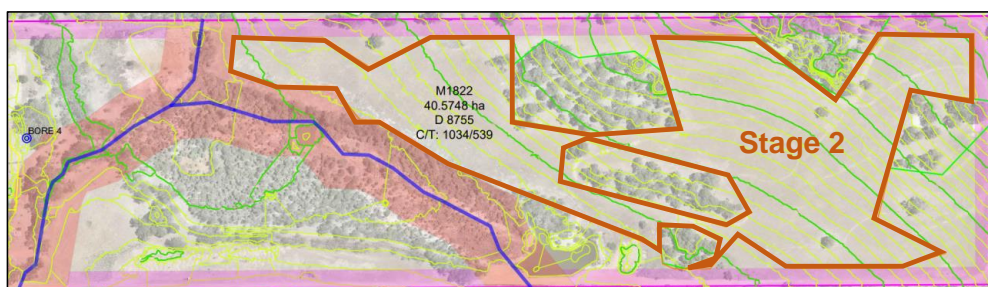

Figure 13: Stage 2 gravel extraction boundary exclusion areas (pink and red shaded areas)

Note excavations undertaken for Stage 1 show that depths can range from 1 m to generally 3 m in depth, and occasionally 4 m depth. An average depth of 2.5 m for excavations across the Stages has been used to project the extraction volumes and tonnes. Photos 1 and 2 show typical gravel excavations.



Photo 1: Excavation showing gravel, clay and laterite



Photo 2: Excavated gravel pit – typical depth

7.1.2 Duration

Periodic gravel extraction and screening will be undertaken on a campaign basis. A campaign would last about three weeks (and a maximum of 8 campaigns are expected during the year). Operational hours will be from 7am to 7pm (in line with noise regulations).

Pending weather conditions and in particular, heavy rainfall events, gravel extraction may not be undertaken in winter months. Topsoil stripping, screening and product storage could be undertaken at the site during these months. Gravel extraction will be limited to mitigate any potential impacts to groundwater given that the perched water table is likely higher to the surface in winter months. Products will be stored on site prior to transport offsite and stockpile management will be put in place with stockpiles not reaching more than 7 metres in height.

7.1.3 Process flow

The process steps in extraction and screening of gravel and rehabilitation are outlined in Figure 14.

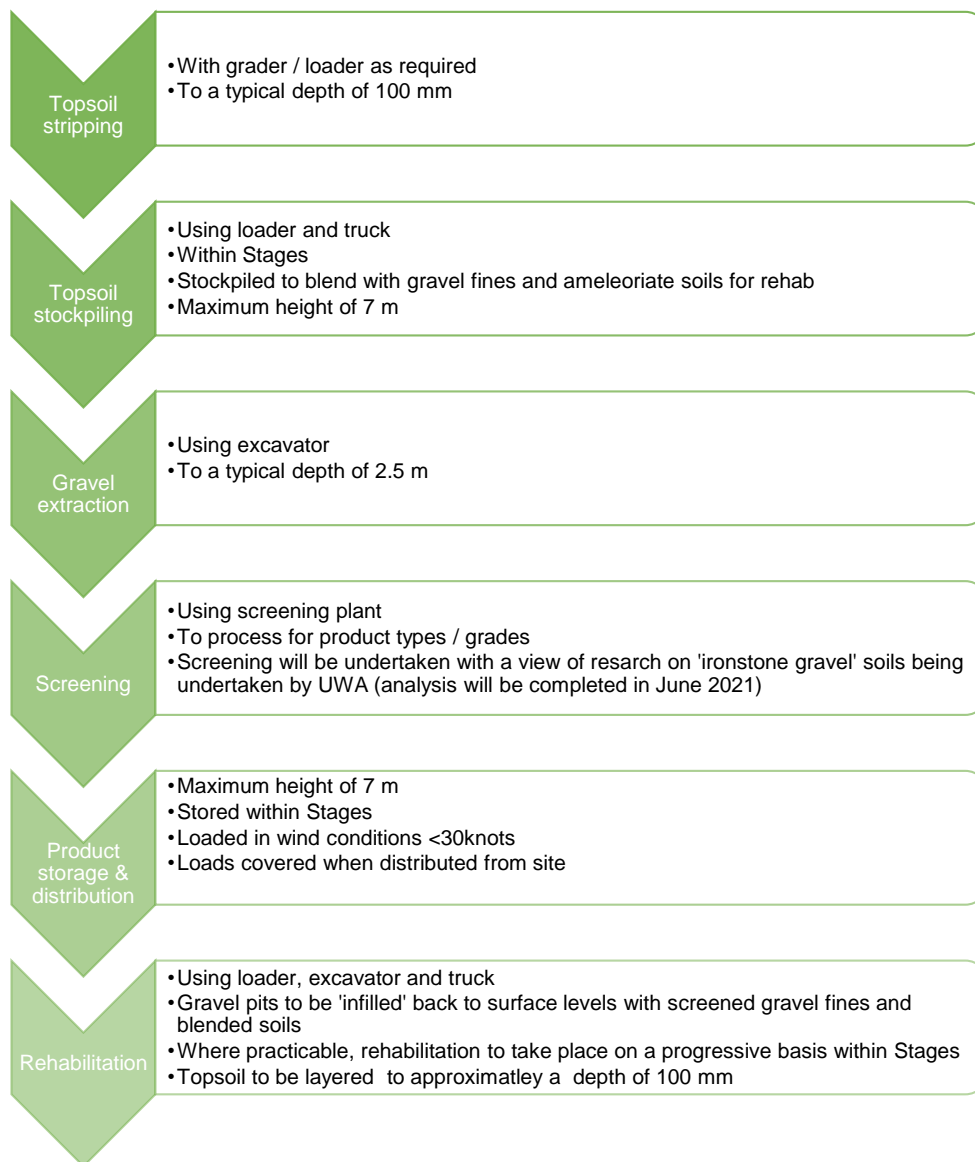

Figure 14: Gravel extraction process flow

7.1.4 Topsoil stripping

Top soil will be stripped to a depth of 100 mm within each Stage. The stripped stockpile will be located adjacent to the relevant excavated area. Stripped top soil during site preparation will be spread directly onto progressively backfilled excavated areas at a depth of 100 mm. Stockpiled top soil will be used for rehabilitation within 2 years to retain any of the soil's biodata. Overburden, when available, will be pushed to the south and west of the Stages extraction area, which will have the added benefit of facilitating visual and noise screening. From there it can be used for the rehabilitation purposes.

7.1.5 Gravel extraction

Gravel extraction is anticipated to a typical depth of 2.5 m across Stages. The gravel will be extracted typically using an excavator and stockpiled within Stage. The extracted gravel will be screened to different grades and separately stockpiled. Predominantly, screened gravel fines will be used to rehabilitate the site (and "infill" the excavated gravel pits).

7.1.6 Constructing gradient stability

Across the base of the gravel pit/s, the excavation will be carried out at a maximum 1:2.5 slope. An access ramp will be constructed at one location for access into the excavation. The access ramps will be maintained at a maximum slope of 1:4 and will have a minimum track width of 4 m. The internal side batters of the pit will have a maximum slope of 1:2.5 for stability. Any unstable section identified on the internal batter during the excavation activity will be reinstated by removing loose material and reducing the slope.

7.2 Rehabilitation Measures

7.2.1 Objective

The primary objective of the rehabilitation plan is to rehabilitate stage 1 and 2 excavated zones to a safe and stable landform to, as close as possible, the original surface levels.

Given the surrounding rural land uses for cropping and grazing and the cleared nature of the site, Capital Recycling will rehabilitate and ameliorate soils in each stage so that the site could be used as a crop land or grazing land.

7.2.2 Surrounding land uses

The site is surrounded by rural properties used for cropping, sheep or cattle grazing with the closest sensitive residential receptors located at 830 m south west of the site. Section 3.2 details the surrounding land uses and receptors within a 5 km radius.

7.2.3 Procedures

The following procedures will be undertaken with respect to rehabilitation measures for the site at stage 1 and 2.

Vegetation Establishment

Capital Recycling, through Encycle Consulting engaged with the University of Western Australia (UWA) School of Agriculture and Environment to develop a soil product blend from the extracted gravel fines on site, on site topsoil and / or from soils brought to rehabilitate the site for improved cropping predominantly for animal feed purposes.

The Grains Research and Development Corporation (GRDC) commissioned UWA to research aims to increase the profitability of grain crops grown on problematic 'ironstone gravel' (as per those soils *in situ* at 366 Horton Road). The research improves knowledge about the properties of gravel soils, which could result in more informed management of the grain crops grown on them.

It is proposed this research would be of benefit to the surrounding rural properties situated on ironstone gravel soils and to the broader farming community located within the Shire of Northam.

Rehabilitation steps include:

- No native vegetation clearing will be undertaken within the Stages of gravel excavation
- Landform reconstruction and contouring
 - The restoration of the excavated gravel pits will be undertaken progressively, where practicable, to minimise emissions and to infill pits to mitigate any potential impacts from winter rains and pooling of water. As excavations will either not be undertaken or will be limited in winter months, pooling of water will not occur or be mitigated
 - Temporary clay bunds will be constructed to further mitigate surface run-off
- Topsoil / overburden removal replacement
 - Where possible topsoil and overburden will be directly transferred from previously stripped excavation areas to an area to be rehabilitated. Topsoil or overburden may be screened to produce an appropriate soil medium for rehabilitation
- Erosion control
 - The finished surface will be left loose and slightly undulating to assist in reduction of surface flow rate and increase the seepage of water into the ground
 - Measures to mitigate surface and groundwater impacts are outlined in section **Error! Reference source not found.**
- Capital has engaged with UWA (through Encycle Consulting) to determine the blend of 'ironstone gravel' with respect to findings on research commissioned by the GDRC on the use of 'ironstone gravel' soils and the rehabilitation of sites for agriculture crops. The purpose of this research is to determine blends of soil products to ameliorate soils and produce higher yields on agricultural properties where 'ironstone gravel' soils is the underlying geology
- Encycle engaged an Honours student to:
 - Review findings from the GDRC research and applicability to the Woottating site

- Develop a soil sampling plan to analyse soils on site and amelioration required to rehabilitate the site for crop land and / or grazing land
 - Recommend rates of gravel to blend with soils and rates of soil to apply for two (2) cropping or grazing species (e.g. ameliorated soils and rates to use for growing maize, lupins etc.)
 - Observe, through visual growth records of crops and growth of roots, how crops performed in the ameliorated soils
 - Write up findings and compare with findings from the GDRC research.
- No vegetation clearing will take place for either Stage 1 or 2 and vegetation has been surveyed and mapped. Note: natural attrition of some vegetation may occur on site in the protected zones
 - There will be no disturbance of the water course bed or bank during excavation / rehabilitation works for the stage 1 or 2
 - Water will not be drawn from the water course for any irrigation requirements and extracted from extraction bore and / or soak on site.

7.3 Weed Management Measures

7.3.1 Definition of weeds

For the purpose of this document, the term 'weed' refers to taxa that are declared plants under the *Biosecurity and Agriculture Management (BAM) Act 2007* and the Biosecurity and Agriculture Management Regulations 2013.

Declared plants are assigned to one of the following control categories under the Biosecurity and Agriculture Management Regulations 2013:

- C1 (Exclusion): plants are not established in WA and control measures are to be taken (including border checks) in order to prevent them entering and establishing in the State
- C2 (Eradication): plants are present in WA in low enough numbers or in sufficiently limited areas that their eradication is still feasible
- C3 (Management) — plants are established in WA but it is feasible, or desirable, to manage them in order to limit their damage. Control measures can prevent a C3 plant pest from increasing in population size or density or moving from an area in which it is established into an area which currently is free of that pest
- Unassigned - declared pests that are recognised as having a harmful impact under certain circumstances, where their subsequent control requirements are determined by a plan or other legislative arrangements under the Act.

The Commonwealth of Australia, in collaboration with the states and territories, has identified 32 Weeds of National Significance (WoNS). This assessment is based on prioritising weeds according to invasiveness, potential for spread and environmental, social and economic impacts. Both landowners and land managers are responsible for the management of WoNS. There are currently 50 plant taxa that are declared pests within the Shire of Northam, 25 of which are also listed as WoNS (refer Appendix A).

7.3.2 Current weed status

The current weed status of the Premises is unknown as a targeted inspection has not been undertaken. Note that Capital Recycling, in conjunction with neighbouring farming properties, undertake weed management practices as necessary and in discussion with surrounding farms and their weed eradication practices prior to cropping.

7.3.3 Objectives

The principal objectives of the weed management plan are to:

- Mitigate the introduction of new weed species and/or the spread of existing weed species to the Premises and its surrounding environment as a result of the proposed gravel extractions
- Control and eradicate any declared weed species located on the Premises.

This weed management plan has been prepared with reference to guidelines published by the (then) Department of Agriculture and Food Western Australia *Guidelines for weed control procedures for extractive industry licence* (DAFWA, 2014).

7.3.4 Weed management zones

As per DAFWA (2014) guidelines, weed management zones have been delineated for the gravel pit extraction areas of Stage 1 and 2, and the exclusion areas i.e. the 20 m boundary off set and the 50 m water course exclusion areas.

Weed management will involve an active weed monitoring program to reduce the potential of any new weed infestations becoming established. This monitoring and control work will be focussed on:

- the weed condition of the land in Stages 1 and 2, and the exclusion areas
- the weed free condition of plant and equipment brought on site
- the weed free condition of any soil that may be brought on site
- the weed free condition of any quarry product exported from site (i.e. extracted from Stages 1 and 2 working areas).

7.3.5 Weed control program

In the event of a weed infestation occurring, a licenced weed management contractor will be responsible for applying the appropriate method of control and / or Capital will coordinate weed management activities with neighbouring farming properties. This includes both mechanical and chemical methods conducted at the appropriate seasonal time. Consideration as to the proximity of the watercourse that dissects the Premises, and the two dams, will be undertaken if chemical control is to be utilised. The weed management contractor will be required to keep a record of all treatments undertaken at the Premises.

To mitigate the import of weeds, all plant and equipment will be clean and free of soil or vegetation when moving to the site. The movement of machinery and other vehicles will be limited within the site, where practicable, to working areas in Stage 1 and 2.

8 Traffic Management Measures

8.1 Objective

To mitigate the potential emissions of vehicle movements to and from site, and maintain Horton Road as per the Shire of Northam Deed Clause 1.1 for the site with Capital Recycling (business trade name)¹³.

8.2 Assessments / Access

The Traffic Impact Statement (Shawmac, TIS 2013), provided as supporting documentation¹⁴, has been reviewed with consideration to gravel operations for the current Category 12 licence (L9251) and application for the EILs. Note that the extracted tonnes for the Category 12 licence and EIL will be undertaken progressively.

Conservatively, Capital Recycling applied for the current DWER Category 12 licence based on the Traffic Impact Statement undertaken by Shawmac of 20 vehicle movements per day during operational days. The 20 vehicle movements per day were based on distribution of bulk products. It is expected that fewer vehicle movements will take place given that gravel is being compacted into block products, that is, volume reduced and the split of product will be 2% bulk gravel product and 98% block products from 2023.

No significant changes have been made to the Great Eastern Highway and lease agreement between Capital Recycling and their neighbouring property at Lot 9249 Carter Road is current (as provided in the extract in Figure 15).

6. USE OF LAND
The Tenant:
(a) must use the Land only for the Permitted Use set out at Item 11 of the Schedule;
(b) must comply on time with all laws and the requirements of authorities in connection with the Land at its sole cost and expense;
(c) may fully use the Land as a road and pass and repass over it with or without any form of vehicle or machinery and may allow any third parties requiring access to or from the Tenant's premises at lot 13 on Diagram 87525 being the whole of the land in certificate of title volume 2026 folio 553 to do the same;
(d) may only use the land between 7.00am and 7.00pm;
(e) shall ensure that the gates to the road are kept locked except during the hours authorised in clause 6(d) above;
(f) must take all reasonable steps to minimise the nuisance the Landlord caused by the use of the Land as a road including but not limited to minimisation of dust and noise from the Land; and
(g) must use its best endeavours to restrict speed of travel along the Land to 50km/hr by: <ul style="list-style-type: none">(i) erecting maximum speed signs;(ii) if necessary the installation of speed humps sufficient to restrict speed on the Land to 50km/hr; and(iii) the erection of a stop sign at the entry point of vehicles onto the road.

Figure 15: Extract of lease agreement on 'use of land' for Carter Road

¹³ Refer supporting documentation 'Attachment: Deed for site 366 Horton Road'

¹⁴ Refer supporting documentation 'Attachment: Shawmac (2013), Traffic Impact Statement'

8.3 Procedures

In addition to the traffic management measures outlined in the noise management and odour management sections of this OEMP, and the above access lease agreement for use of Carter Road to minimise any impacts on local roads, Capital Recycling will:

- Use trucks that are well maintained, serviced regularly and with up-to-date engine standards to minimise noise impacts
- Instruct drivers and any contractors to minimise the use of exhaust brakes on Carter Road and Horton Road
- Backload trucks, where possible, to minimise the number of vehicle movements
- Induct and brief drivers and contractors on the local operational requirements to minimise impact on Carter Road and Horton Road
- Induct and brief drivers to enter and exit the site via Great Eastern Highway / Carter Road intersection only to mitigate the potential impact on local roads
- Register and investigate any complaints to review and implement measures, if necessary, to mitigate impacts.

9 Fire Management

Capital engaged Bushfire Protection Australia and a 'Bushfire Management Plan' has been prepared for the site and is provided as supporting information to the Shire of Northam EIL and DA applications¹⁵.

¹⁵ Refer supporting documentation 'Bushfire Protection Australia (2020), Bushfire Management Plan – Capital'

10 Environmental Complaints Register



19 Felspar Street
Welshpool WA 6106

Ph: (08) 9279 4599
www.capitalrecycling.com.au

info@capitalperth.com.au
ar@capitalperth.com.au (Accounts)

Capital Yard or Site Complaint Form

To be completed by the senior employee receiving details of the complaint

Date:	1/5/2020	Site:	Gravel Pit
Person receiving complaint:	John Smith	How was the complaint made?	Phone call
Name of Complainant:	Fred Farmer		
Details of complaint:	Fred phoned HO who immediately rang me as site supervisor. Fred had observed plumes of dust from loader loading trucks potentially crossing property boundary.		
Action taken:	Stopped loading. Increased water spray onto stock pile being loaded. This worked initially but wind strength increased so loading trucks was abandoned till next day		
Reported action to:	General Manager	Follow up required:	no
Does the incident require report to the appropriate authorities (i.e. DWER or Local Government)?	Listed for annual report		
Any other details/information:	-		
Close Complaint:	2/5/2020		
Signature:	J. Smith	Date:	2/5/2020

Page 1

Farfield Holdings Pty Ltd ATFT R Gullotto FM TST T-AS | ACN 104086320 | ABN 44 603 462 405

11 Training & Record Keeping

11.1 Training

All Capital Recycling employees will be required to undergo a site-specific induction, outlining the operational activity controls in this OEMP to mitigate potential environmental emissions.

The induction will provide necessary awareness of dust, noise and water management and the actions and work practices to minimise emissions. Regular toolbox meetings will also be held to reinforce a positive attitude towards best practices for environmental management and to highlight any issues that arise during the course of construction.

A record of all training will be maintained.

11.2 Reporting

The Site Supervisor will be responsible for conducting periodic environmental monitoring for dust and noise, and groundwater level measurements and filing copies.

11.2.1 Dust

All employees will be required to report any generation of significant dust emissions and especially any that may threaten to cross the Premises boundary to the Site Supervisor.

In the event that dust migrates beyond the Premises boundary, dust suppression measures will be immediately reviewed to ensure practices are being followed and / or to implement more stringent measures. Such measures could include the cessation of activities in the event of extreme adverse weather conditions. Pending the severity of potential dust migration, the Site Supervisor will implement mitigation measures immediately on site, or discuss continual improvements measures with the General Manager.

11.2.2 Noise

In the event that noise complaints are received, noise mitigation measures will be immediately reviewed to ensure practices are being followed and / or to implement more stringent measures. Such measures could include the limit of a combination of operational activities. In the event of continued noise complaints, Capital Recycling will undertake a noise impact assessment and implement recommended strategies.

11.2.3 Water

Capital Recycling engage a specialist environmental company to undertake surface and groundwater monitoring for submission and analysis to a NATA accredited laboratory.

EVA Environmental has been engaged to assess and interpret water analysis and complete the DWER Annual Compliance Report in line with licence conditions.

Appendix A Weed Species

Declared plants for the Shire of Northam¹⁶

Family	Taxon	Control Category	Weeds of National Significance (WoNS)
Alismataceae	<i>Sagittaria platyphylla</i>	C3	Yes
Apocynaceae	<i>Calotropis procera</i>	Unassigned	No
	<i>Cryptostegia madagascariensis</i>	Unassigned	No
	<i>Gomphocarpus fruticosus</i>	C3	No
Araceae	<i>Pistia stratiotes</i>	C2	No
	<i>Zantedeschia aethiopica</i>	Unassigned	No
Araliaceae	<i>Hydrocotyle ranunculoides</i>	C3	No
Asparagaceae	<i>Asparagus asparagoides</i>	Unassigned	Yes
Asteraceae	<i>Chondrilla juncea</i>	C2, C3	No
	<i>Onopordum acaulon</i>	Unassigned	No
	<i>Silybum marianum</i>	Unassigned	No
	<i>Xanthium spinosum</i>	C2, C3	No
	<i>Xanthium strumarium</i>	C2, C3	No
Boraginaceae	<i>Echium plantagineum</i>	Exempt	No
Cactaceae	<i>Austrocylindropuntia cylindrica</i>	C3	Yes
	<i>Austrocylindropuntia subulata</i>	C3	Yes
	<i>Cylindropuntia fulgida</i>	C3	Yes
	<i>Cylindropuntia imbricata</i>	C3	Yes
	<i>Cylindropuntia kleiniae</i>	C3	Yes
	<i>Cylindropuntia pallida</i>	C3	Yes
	<i>Cylindropuntia tunicata</i>	C3	Yes
	<i>Opuntia elata</i>	C3	Yes
	<i>Opuntia elatior</i>	C3	Yes
	<i>Opuntia engelmannii</i>	C3	Yes
	<i>Opuntia microdasys</i>	C3	Yes
	<i>Opuntia monacantha</i>	C3	Yes
	<i>Opuntia polyacantha</i>	C3	Yes
	<i>Opuntia puberula</i>	C3	Yes

¹⁶ Department of Primary Industries and Resources Development (2022), Western Australian Organism List; Online database available at <https://www.dpir.wa.gov.au/organisms>; Weeds Australia (2022), Weeds of National Significance (WoNS); Online database available at <https://weeds.org.au/weeds-profiles/>

Family	Taxon	Control Category	Weeds of National Significance (WoNS)
	<i>Opuntia stricta</i>	C3	Yes
	<i>Opuntia tomentosa</i>	C3	Yes
Euphorbiaceae	<i>Jatropha gossypifolia</i>	C3	Yes
Fabaceae	<i>Alhagi maurorum</i>	C3	No
	<i>Parkinsonia aculeata</i>	C3	Yes
	<i>Prosopis glandulosa x velutina</i>	C2, C3	Yes
	<i>Senna alata</i>	Unassigned	No
	<i>Senna obtusifolia</i>	Unassigned	No
	<i>Ulex europaeus</i>	C2, C3	Yes
Iridaceae	<i>Moraea flaccida</i>	Unassigned	No
	<i>Moraea miniata</i>	Unassigned	No
Rhamnaceae	<i>Ziziphus mauritiana</i>	C3	No
Rosaceae	<i>Rubus anglocandicans</i>	C3	No
	<i>Rubus laudatus</i>	C3	No
	<i>Rubus rugosus</i>	C3	No
	<i>Rubus ulmifolius</i>	C3	No
Rubiaceae	<i>Galium aparine</i>	Unassigned	No
	<i>Galium spurium</i>	Unassigned	No
Solanaceae	<i>Solanum elaeagnifolium</i>	Unassigned	Yes
	<i>Solanum linnaeanum</i>	Unassigned	No
Tamaricaceae	<i>Tamarix aphylla</i>	Unassigned	Yes
Verbenaceae	<i>Lantana camara</i>	C3	Yes

Appendix B Material Acceptance Procedure



1 Purpose

To provide appropriate controls relating to the acceptance of material to the Woottating site.

2 Scope

This procedure refers to material receipt and inspection

3 Definitions and Glossary

MR - Management Representative, SS - Site Supervisor

4 Procedure

MR is responsible for the implementation of this procedure and for delegating responsibility to the SS. The Sales Division is responsible for receiving orders / order enquiries and to relay information on services appropriately including initial assessment of proposed operational activities.

4.1 Materials receipt and inspection

- A material receipt inspection is carried out to ensure:
 - Material that cannot be accepted is:
 - Construction & Demolition materials (i.e. concrete, bricks, rubble etc.)
 - Material from suspected or classified contaminated sites
 - Material from industrial premises / activities
 - Any material suspected of contamination through visual observations
 - Material that can be accepted:
 - Material from the residential sector, predominantly from vegetated areas
 - Material from land clearing works (i.e. clay, basement digs etc.)
 - Purchased topsoil / fill material
- A purchase order or service agreement which includes specifications for the material that is accepted is sent to customer
- Inspection of material at site is undertaken prior to works
- Once site inspected materials have been transported to site, material is inspected at the feedstock receival area once unloaded
- Acceptance or rejection of consignments loads is undertaken. If suspected contamination, arrangements will be made to back-load vehicles and dispose of material to appropriately licensed facility
- Delivery note will be issued on acceptance of material
- The MR will arrange bi-annual (2 campaigns) sampling of material with the SS in the first year.



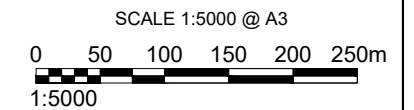
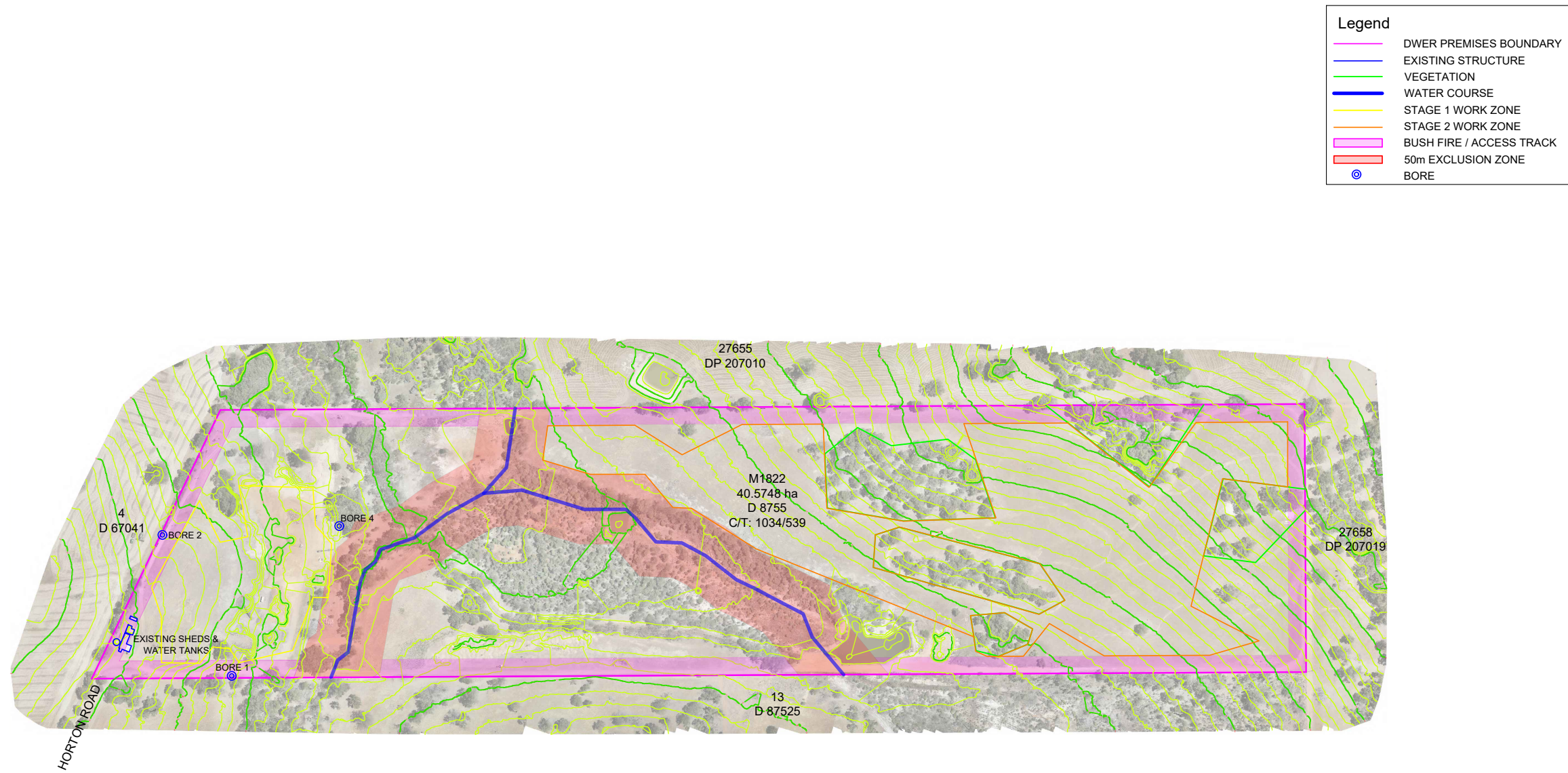

REV	DATE	DESCRIPTION	DRAWN	SURVEYOR	APPROVED
A	15/03/2022	CONTOUR FEATURE SURVEY	PS	-	PS

CLIENT: CAPITAL RECYCLING	PROJECTION: HORIZONTAL : Approx. MGA 94 VERTICAL : Approx. AHD	LIMITATIONS OF USE The contents of this plan are current and correct as of the date stated within the revision panel. All consultants and persons intending to use this data should satisfy themselves of the plans currency by contacting Total Project Consultants.
-------------------------------------	--	--



No 366 HORTON ROAD WOOTTATING
STAGES 1 & 2 WORK ZONES

JOB No: J2020163
PLAN No: J2020163 10
SCALE: 1:5000 @ A3
REVISION: A
SHEET: 1 OF 1

P23000 – Incidental Block Making

Statutory Assessment

An assessment of the applicable provisions of LPS6, including the Deemed Provisions and LPPs have been carried out as follows:

Clause	Provision	Proposal	Assessment
Deemed Provisions – Clause 67(2) of Regulations			
A	Aims and provisions of LPS6		
	3.3.1	Zoning Table indicates permissibility: Rural – Extractive Industry 'A'	Incidental use to approved extractive industry. Refer to clause 3.3.2
	3.3.2	'I' means that the use is permitted if it is consequent on, or naturally attaching, appertaining or relating to the predominant use of the land and it complies with any relevant development standards and requirements of LPS6.	To develop an incidental block making operation from the gravel extracted on site to supply to wholesale markets, such as landscaping supplies and local trades for building retaining walls, etc. Proposed product split of 98% block products and 2% bulk gravel product. Development proposal is consequent on and naturally attaching to the predominant approved use of the site as an extractive industry.
	4.5	Site and development standards: Rural boundary setbacks – 25m front; 20m sides and rear.	Setbacks as indicated in Figure 2 of OEMP. Setbacks comply.
	4.8	Outdoor storage areas to be sealed, paved, screened and/or landscaped to the local government's satisfaction.	Outdoor block drying and storage area proposed. Area is located within the property at the end of Horton Road. Location will not impact the visual amenity of the area. Existing vegetation sufficient to screen area from neighbouring properties.
	4.16	Provision to be made for access and loading, including provisions for vehicles to enter and leave in a forward direction, to the satisfaction of the local government.	Existing access to be utilised. Figure 2 of OEMP depicts access, loading and manoeuvring areas with all vehicles entering and leaving in a forward direction. Complies. Access and loading areas are adequate.
	4.19	Land between the street alignment and front building setback may be used for gardens and other landscaping; access driveways; and vehicle parking to the satisfaction of the local government.	Front and side setback areas (depicted in pink in Figure 2 of OEMP) identified for use for access driveways. Complies.

Clause	Provision	Proposal	Assessment
	4.31 Amenity of non-residential development shall be determined in the context of the proposed development and site conditions, generally in accordance with: a) Form and scale to be compatible with surrounding land uses b) Buildings to have coordinated or complementary materials, colours and styles and be reflective of character of the locality; c) Visual impacts are to be minimised by use of vegetation screening and tree retention.	Proposed block making activities to consist of concrete hardstands for housing equipment and the mixing/manufacturing area.	The proposed infrastructure is compatible with the approved use of the site and locality, which includes Purearth and BGC.
B	Requirements of orderly and proper planning, including any proposed scheme amendment or LPP seriously being entertained.	Incidental block making to approved extractive industry.	Application submitted in accordance with the provisions of LPS6.
FA	Any local planning strategy – Northam LPS	Incidental block making to approved extractive industry.	Use of property is consistent with the intent of the locality and rural zone.
I	Any report of review – LPS6 Report of Review	Incidental block making to approved extractive industry.	Report does not affect proposal.
M	Compatibility of the development, including future character and relationship with adjoining land	Incidental block making to approved extractive industry.	Development is compatible with the current use and locality. Potential impacts can be managed through conditions.
N	Amenity of the locality, including environmental impacts, character and social impacts.	Incidental block making to approved extractive industry.	Potential impacts identified in the assessment are – noise, dust and traffic. Mitigation can be achieved through conditions.
O	Likely effect on the natural environment or water resources and means to mitigate.	Construction of two drainage basins to manage stormwater runoff from hardstand areas.	Mitigation measures are sufficient to manage potential impacts.
P	Adequate provision for landscaping of the land or protection of trees or other vegetation	No tree removal proposed.	Condition to be imposed ensuring no tree removal without approval. Landscaping deemed not necessary due to location.

Clause	Provision	Proposal	Assessment
Q	Suitability of the land taking into account of possible risks, such as bushfire, flooding, erosion.	Bushfire management plan approved as part of the extractive industry.	The proposed activity does not increase the bushfire risk. Existing plan adequate to manage risks.
S	Adequacy of proposed means of access and egress; arrangements for loading, unloading, manoeuvring and parking	Existing access to be utilised. Figure 2 of OEMP depicts access, loading and manoeuvring areas with all vehicles entering and leaving in a forward direction.	Complies. Access and loading areas are adequate.
T	Amount of traffic likely to be generated in relation to capacity of road system and probable effect on traffic flow and safety	Traffic is expected to reduce as a result of the new activity. Traffic impact assessment conducted as part of original development.	Existing condition on extractive industry approval to be reimposed on any approval requiring contribution to maintenance of Horton Road and consultation with the Shire of Mundaring.
W	History of the site where development is located	Incidental use to approved extractive industry use.	As outlined in the Report.
X	Impact on the community as a whole notwithstanding impacts on particular individuals	Incidental use to approved extractive industry use.	No impacts identified.

13.4 CORPORATE SERVICES

13.4.1 Accounts & Statements of Accounts - 1 February 2023 to 28 February 2023

File Reference:	2.1.3.4
Reporting Officer:	Louise Harris (Creditors Officer)
Responsible Officer:	Colin Young (Executive Manager Corporate Services)
Officer Declaration of Interest:	Nil.
Voting Requirement:	Simple Majority
Press release to be issued:	No

BRIEF

For Council to receive the accounts for the period from 01st February 2023 to 28th February 2023.

ATTACHMENTS

1. Accounts & Statements of Accounts - February 2023 [**13.4.1.1** - 54 pages]
2. Declaration February 2023 (1) [**13.4.1.2** - 3 pages]

A. BACKGROUND / DETAILS

The reporting of monthly financial information is a requirement under section 6.4 of the Local Government Act 1995, and Regulation 34 of the Local Government (Financial Management) Regulations.

Pursuant to Financial Management Regulation 13, a list of payments made from Municipal and Trust accounts is required to be presented to Council on a periodical basis. These details are included as Attachment 1. In accordance with Financial Management Regulation 12, the Chief Executive Officer has delegated authority to make these payments.

B. CONSIDERATIONS

B.1 Strategic Community / Corporate Business Plan

Performance Area: Performance. Outcome 12: Excellence in organisational performance and customer service.

Objective 12.1: Maintain a high standard of corporate governance and financial management.

Priority Action: Nil.

B.2 Financial / Resource Implications

Payments of accounts are in accordance with Council's 2022/2023 Budget.

B.3 Legislative Compliance

Section 6.4 & 6.26(2) (g) of the Local Government Act 1995.
Financial Management Regulations 2007, Regulation 12 & 13.

B.4 Policy Implications

Nil.

B.5 Stakeholder Engagement / Consultation

Not applicable.

B.6 Risk Implications

Risk Category	Description	Rating (likelihood x consequence)	Mitigation Action
Financial	Figures not reflecting the true financial situation	Rare (2) x Medium (3) = Low (3)	There are processes in place to show compliance with relevant legislation
Health & Safety	N/A	N/A	N/A
Reputation	N/A	N/A	N/A
Service Interruption	N/A	N/A	N/A
Compliance	Report not being accepted by Council	Rare (2) x Medium (3) = Low (3)	There are processes in place to show compliance with relevant legislation
Property	N/A	N/A	N/A
Environment	N/A	N/A	N/A

B.7 Natural Environment Considerations

Nil.

C. OFFICER'S COMMENT

The matter of Council 'supporting local businesses' has been raised over a long period. To assist in providing a greater understanding of the purchasing patterns of the Shire of Northam, the following graph summarises the payments made locally for the month of February 2023:

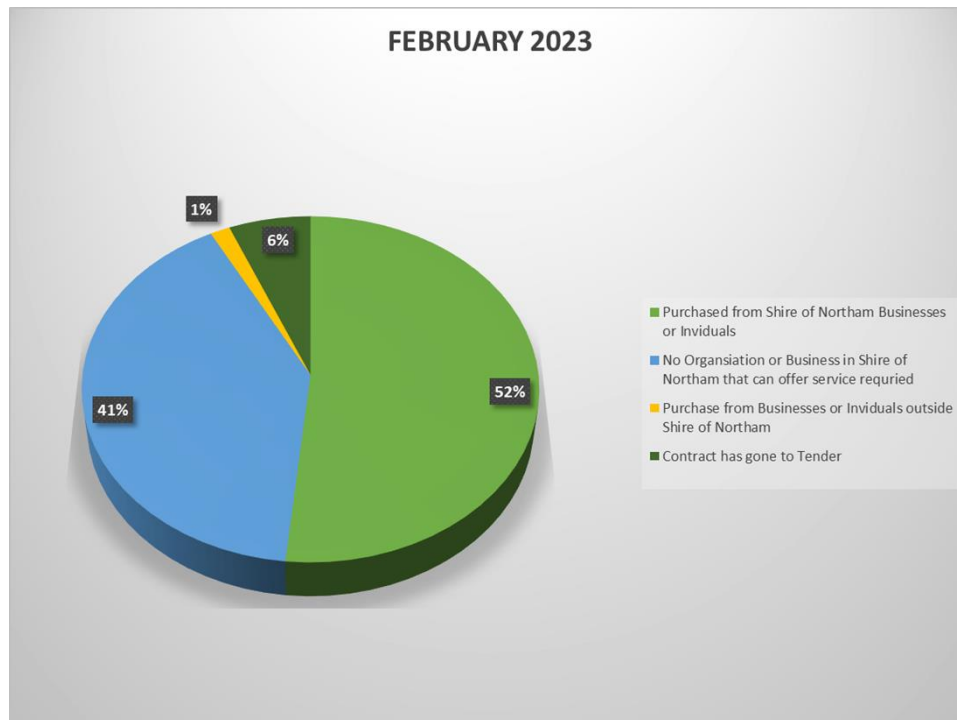

RECOMMENDATION / COUNCIL DECISION

Minute No: C.4694

Moved: Cr D A Hughes

Seconded: Cr A J Mencshelyi

That Council receive the payments for the period 1st February 2023 to 28th February 2023, as listed:

- Municipal Fund payment cheque numbers 35556 to 35560 Total \$44,706.25.
- Municipal Fund EFT46316 to EFT46589 Total \$1,775,425.15
- Direct Debits Total \$47,888.67
- Payroll Total \$532,957.08

TOTAL: \$2,400,977.15

Which have been made in accordance with the delegated authority reference number (M/F/F/Regs LGA 1995 S5.42).

CARRIED 8/0

Ordinary Council Meeting Minutes
15 March 2023

Attachment 13.4.1.1

Date: 01/03/2023
Time: 8:24:14AM

Shire of Northam

USER: Louise Harris
PAGE: 1

Cheque /EFT No	Date	Name	Invoice Description	Bank Code	INV Amount	Amount
35556	09/02/2023	WATER CORPORATION	9007917293 BERT HAWKE OVAL - 21/11/2022 to 19/01/2023	1		11,478.07
INV 9007948405/01/2023		WATER CORPORATION	9007948401 IRISHTOWN HALL - 02/11/2022 to 03/01/2023		5.59	
INV 9007908616/01/2023		WATER CORPORATION	9007908696 KILLARA DAYCARE CENTRE - 09/11/2022 to 12/01/2023		1,957.32	
INV 9008729817/01/2023		WATER CORPORATION	9008729809 NORTHAM VISITORS CENTRE - 09/11/2022 to 13/01/2023		1,509.24	
INV 9007917223/01/2023		WATER CORPORATION	9007917293 BERT HAWKE OVAL - 21/11/2022 to 19/01/2023		3,493.45	
INV 9022053223/01/2023		WATER CORPORATION	9022053227 STANDPIPE - OPP 53 CLARKE ST NORTHAM - 21/11/2022 to 19/01/2023		295.99	
INV 9023586925/01/2023		WATER CORPORATION	9023586906 NORTHAM AQUATIC FACILITY - 01/07/2022 to 11/01/2023		435.35	
INV 9021499427/01/2023		WATER CORPORATION	9021499489 OLD NORTHAM POOL - GREAT EASTERN HIGHWAY - 24/11/2022 to 24/01/2023		194.84	
INV 9007918427/01/2023		WATER CORPORATION	9007918464 PERINA PARK - 23/11/2022 to 24/01/2023		741.21	
INV 9007923627/01/2023		WATER CORPORATION	9007923634 SWIMMING POOL HOUSE - 55 MITCHELL AV NORTHAM LOT 17 - 24/11/2022 to 24/01/2023		246.67	
INV 9007925927/01/2023		WATER CORPORATION	9007925904 RESERVE - NEWCASTLE RD NORTHAM LOT 28472 RES 32386 - 23/11/2022 to 24/01/2023		1,818.05	
INV 9010596331/01/2023		WATER CORPORATION	9010596320 GEORGE NUICH PARK - 29/11/2022 to 27/01/2023		780.36	
35557	17/02/2023	PETTY CASH	PETTY CASH - BKB - JUL 2022 - JAN 2023 - COLES / WOOLIES / RED DOT / THIRSTY CAMEL	1		199.85
INV CG 1402214/02/2023		PETTY CASH	PETTY CASH - BKB - JUL 2022 - JAN 2023 - COLES / WOOLIES / RED DOT / THIRSTY CAMEL	1	199.85	
35558	17/02/2023	WATER CORPORATION	9007840281 GRASS VALLEY HALL - 02/12/2022 to 08/02/2023	1		4,428.12
INV 9007923501/02/2023		WATER CORPORATION	9007923503 MEDIAN STRIP NEWCASTLE RD - 24/11/2022 to 24/01/2023		44.75	
INV 9007925901/02/2023		WATER CORPORATION	9007925971 RUBBISH DEPOT AT OLD QUARRY RD NORTHAM LOT 422 RES 26840 - 24/11/2022 to 30/01/2023		654.50	
INV 9007926001/02/2023		WATER CORPORATION	9007926034 SPORTS GROUND AT COLEBATCH ST NORTHAM LOT 29 RES 5503 - 24/11/2022 to 30/01/2023		154.17	

**Ordinary Council Meeting Minutes
15 March 2023**

Attachment 13.4.1.1

Date: 01/03/2023
Time: 8:24:14AM

Shire of Northam

USER: Louise Harris
PAGE: 2 10

No	Date	Name	Invoice Description	Code	Amount	Amount
INV 9007927501/02/2023		WATER CORPORATION	9007927571 OLD QUARRY RD REFUSE SITE - RUBBISH DEPOT AT OLD QUARRY RD NORTHAM LOT 422 RES 26840 - 24/11/2022 to 30/01/2023		111.88	
INV 9007938907/02/2023		WATER CORPORATION	9007938967 STANDPIPE - BODEGUERO WAY WUNDOWIE - 28/11/2022 to 05/02/2023		295.99	
INV 9023164008/02/2023		WATER CORPORATION	9023164076 CLACKLINE POST OFFICE - 29/11/2022 to 06/02/2023		103.49	
INV 9007891709/02/2023		WATER CORPORATION	9007891775 HOOPER PARK - 01/12/2022 to 07/02/2023		525.84	
INV 9007892509/02/2023		WATER CORPORATION	9007892559 BAKERS HILL REC CENTRE - 01/12/2022 to 07/02/2023		746.61	
INV 9007947909/02/2023		WATER CORPORATION	9007947919 FOX RD STOCK ANIMAL POUND - 01/12/2022 to 07/02/2023		195.79	
INV 9007840210/02/2023		WATER CORPORATION	9007840214 STANDPIPE - KEANE ST GRASS VALLEY - 05/12/2022 to 08/02/2023		305.21	
INV 9007840310/02/2023		WATER CORPORATION	9007840302 GRASS VALLEY BFB FIRE SHED - 02/12/2022 to 08/02/2023		41.96	
INV 9007840210/02/2023		WATER CORPORATION	9007840281 GRASS VALLEY HALL - 02/12/2022 to 08/02/2023		1,236.74	
INV 9007840910/02/2023		WATER CORPORATION	9007840919 GRASS VALLEY MUSEUM - 02/12/2022 to 08/02/2023		11.19	
35559	23/02/2023	SHIRE OF NORTHAM	MONTHLY BSL FEES COLLECTED FOR THE BUILDING COMMISSION FOR THE MONTH OF JANUARY 2023	1		78.25
INV T1080	22/02/2023	SHIRE OF NORTHAM	MONTHLY BSL FEES COLLECTED FOR THE BUILDING COMMISSION FOR THE MONTH OF JANUARY 2023	1	70.00	
INV T1079	22/02/2023	SHIRE OF NORTHAM	PAYMENT FOR COLLECTION OF BCITF FEES ON BEHALF OF THE CONSTRUCTION TRAINING FUND FOR THE MONTH OF JANUARY 2023	1	8.25	
35560	23/02/2023	WATER CORPORATION	9007938748 STANDPIPE - LOCKYER RD CLACKLINE - 29/11/2022 to 06/02/2023	1		28,521.96
INV 9007938708/02/2023		WATER CORPORATION	9007938748 STANDPIPE - LOCKYER RD CLACKLINE - 29/11/2022 to 06/02/2023		9,104.79	
INV 9007891809/02/2023		WATER CORPORATION	9007891839 STANDPIPE - KEANE ST BAKERS HILL - 01/12/2022 to 07/02/2023		7,681.21	
INV 9007868917/02/2023		WATER CORPORATION	9007868997 WUNDOWIE PUBLIC TOILETS - 12/12/2022 to 15/02/2023		2,872.86	

**Ordinary Council Meeting Minutes
15 March 2023**

Attachment 13.4.1.1

Date: 01/03/2023
Time: 8:24:14AM

Shire of Northam

USER: Louise Harris
PAGE: 3 10

No	Date	Name	Invoice Description	Code	Amount	Amount
INV 9007869117/02/2023		WATER CORPORATION	9007869105 R.E.E.D. WUNDOWIE (FLUFFLY DUCKS) - 12/12/2022 to 15/02/2023		877.10	
INV 9007869117/02/2023		WATER CORPORATION	9007869121 WUNDOWIE LIBRARY & GARDENS - 12/12/2022 to 15/02/2023		1,124.68	
INV 9007871817/02/2023		WATER CORPORATION	9007871897 WUNDOWIE SKATE PARK - 12/12/2022 to 15/02/2023		215.86	
INV 9007871917/02/2023		WATER CORPORATION	9007871918 WUNDOWIE OVAL - 12/12/2022 to 15/02/2023		1,021.40	
INV 9007871917/02/2023		WATER CORPORATION	9007871993 WUNDOWIE DEPOT - LESCHENAULTIA - 13/12/2022 to 15/02/2023		123.07	
INV 9007872217/02/2023		WATER CORPORATION	9007872232 KURINGAL VILLAGE - SERVICE - 13/12/2022 to 15/02/2023		44.57	
INV 9007872217/02/2023		WATER CORPORATION	9007872240 KURINGAL VILLAGE - UNIT 1 - 13/12/2022 to 15/02/2023		258.10	
INV 9007872217/02/2023		WATER CORPORATION	9007872259 KURINGAL VILLAGE - UNIT 2 - 13/12/2022 to 15/02/2023		296.20	
INV 9007872217/02/2023		WATER CORPORATION	9007872267 KURINGAL VILLAGE - UNIT 3 - 13/12/2022 to 15/02/2023		253.34	
INV 9007872217/02/2023		WATER CORPORATION	9007872275 KURINGAL VILLAGE - UNIT 4 - 13/12/2022 to 15/02/2023		257.15	
INV 9007872217/02/2023		WATER CORPORATION	9007872283 KURINGAL VILLAGE - UNIT 5 - 13/12/2022 to 15/02/2023		267.63	
INV 9007872217/02/2023		WATER CORPORATION	9007872291 KURINGAL VILLAGE - UNIT 6 - 13/12/2022 to 15/02/2023		296.20	
INV 9007872317/02/2023		WATER CORPORATION	9007872304 KURINGAL VILLAGE - UNIT 7 - 13/12/2022 to 15/02/2023		280.96	
INV 9007872317/02/2023		WATER CORPORATION	9007872312 KURINGAL VILLAGE - UNIT 8 - 13/12/2022 to 15/02/2023		281.91	
INV 9007868517/02/2023		WATER CORPORATION	9007868583 WUNDOWIE SWIMMING POOL - 13/12/2022 to 15/02/2023		1,878.57	
INV 9007869120/02/2023		WATER CORPORATION	9007869148 WUNDOWIE TOWN HALL - 12/12/2022 to 15/02/2023		1,386.36	
EFT46316	02/02/2023	AINSLIE GATT ART VALUATION	APPRAISAL OF ARTWORKS	1		3,250.00
INV IV00002323/01/2023		AINSLIE GATT ART VALUATION	APPRAISAL OF ARTWORKS	1	3,250.00	
EFT46317	02/02/2023	ALEXANDER COOMBES	PA HIRE, DELIVERY & DAY RATE FOR AUST DAY CEREMONY	1		600.00

**Ordinary Council Meeting Minutes
15 March 2023**

Attachment 13.4.1.1

Date: 01/03/2023
Time: 8:24:14AM

Shire of Northam

USER: Louise Harris
PAGE: 4 10

Cheque /EFT No	Date	Name	Invoice Description	Bank Code	INV Amount	Amount
INV 0000069	18/01/2023	ALEXANDER COOMBES	PA HIRE, DELIVERY & DAY RATE FOR AUST DAY CEREMONY	1	600.00	
EFT46318	02/02/2023	ALLISON CONTRACTING AND BOILER MAKING - JACOB ALLISON T/AS	SUPPLY MATERIALS AND CONSTRUCT CANOPY TO FIT PN1612 AS PER QUOTE QU-0006	1		8,151.00
INV INV-004122	01/2023	ALLISON CONTRACTING AND BOILER MAKING - JACOB ALLISON T/AS	SUPPLY MATERIALS AND CONSTRUCT CANOPY TO FIT PN1612 AS PER QUOTE QU-0006	1	8,151.00	
EFT46319	02/02/2023	ANDY'S PLUMBINGSERVICE	YOUTH PARK TOILET. UNBLOCK 2 X AMBLIENT TOILETS.	1		1,122.00
INV A19478	18/01/2023	ANDY'S PLUMBINGSERVICE	YOUTH PARK TOILET. UNBLOCK 2 X AMBLIENT TOILETS.	1	517.00	
INV A19477	18/01/2023	ANDY'S PLUMBING SERVICE	INSPECT BERNARD PARK WATERPARK BACKWASH LINE AND PROVIDE TECHNICAL ADVISE	1	220.00	
INV A19479	24/01/2023	ANDY'S PLUMBING SERVICE	BERNARD PARK TOILETS. MONTHLY ROUTINE MAINTENANCE OF WATERLESS URINALS AND CISTERNS.DEC 2022	1	385.00	
EFT46320	02/02/2023	ASTROTOURISM WA PTYLTD	ASTROTOURISM TOWNS MEMBERSHIP 2022/23 & STARGAZING EVENT DATED 22/4/2023	1		4,400.00
INV 1192	24/11/2022	ASTROTOURISM WA PTYLTD	ASTROTOURISM TOWNS MEMBERSHIP 2022/23 & STARGAZING EVENT DATED 22/4/2023	1	4,400.00	
EFT46321	02/02/2023	AVON VALLEY GARDEN SERVICE	FUEL REDUCTION A12493 48 PERINA WAY	1		330.00
INV IV1857	20/12/2022	AVON VALLEY GARDEN SERVICE	FUEL REDUCTION A12493 48 PERINA WAY	1	165.00	
INV IV1902	17/01/2023	AVON VALLEY GARDEN SERVICE	FUEL REDUCTION A10513 8 DICK STREET	1	165.00	
EFT46322	02/02/2023	BEATUM PTY LTD ATF E&K FAMILY TRUST	2022 STAFF XMAS PARTY	1		5,308.50
INV INV-004216	12/2022	BEATUM PTY LTD ATF E&K FAMILY TRUST	2022 STAFF XMAS PARTY	1	5,308.50	
EFT46323	02/02/2023	BELINGARNI FABRICATION HOME AND PROPERTY SERVICES	FUEL REDUCTION A12348 13 TURNER STREET NORTHAM A14009 41 MORRELL ST NORTHAM A12354 19 TURNER STREET NORTHAM	1		2,013.00

**Ordinary Council Meeting Minutes
15 March 2023**

Attachment 13.4.1.1

Date: 01/03/2023
Time: 8:24:14AM

Shire of Northam

USER: Louise Harris
PAGE: 5 10

Cheque /EFT No	Date	Name	Invoice Description	Bank Code	INV Amount	Amount
INV 975	19/01/2023	BELINGARNI FABRICATION HOME AND PROPERTY SERVICES	FUEL REDUCTION A12348 13 TURNER STREETNORTHAM A14009 41 MORRELL ST NORTHAM A12354 19 TURNER STREETNORTHAM	1	858.00	
INV 976	19/01/2023	BELINGARNI FABRICATION HOME AND PROPERTY SERVICES	FUEL REDUCTION A14262 114 THROSSELL ST NORTHAM A12300 74 THROSSELL ST NORTHAM	1	440.00	
INV 977	19/01/2023	BELINGARNI FABRICATION HOME AND PROPERTY SERVICES	FUEL REDUCTION A12494 8 WELLINGTON ST NORTHAM A11900 5 STOKE AVENUE NORTHAM	1	495.00	
INV 978	19/01/2023	BELINGARNI FABRICATION HOME AND PROPERTY SERVICES	FUEL REDUCTION A10382 46 BURNSIDE AVE NORTHAM	1	220.00	
EFT46324	02/02/2023	BLACKWELL PLUMBING AND GAS PTY LTD	REPAIR OF BLOCKED URINAL	1		225.50
INV INV-274514/12/2022		BLACKWELL PLUMBING AND GAS PTY LTD	REPAIR OF BLOCKED URINAL	1	225.50	
EFT46325	02/02/2023	BOC LIMITED	11 X 400C OXYGEN MEDICAL C SIZE* RENTAL FEE 29/12/2022 - 28/01/2023	1		71.20
INV 4033122129/01/2023		BOC LIMITED	11 X 400C OXYGEN MEDICAL C SIZE* RENTAL FEE 29/12/2022 - 28/01/2023	1	71.20	
EFT46326	02/02/2023	BOLINDA PUBLISHING PTY LTD	LARGE PRINT BOOKS FOR LOCAL STOCK REQUESTS	1		160.38
INV 282349	18/01/2023	BOLINDA PUBLISHING PTY LTD	LARGE PRINT BOOKS FOR LOCAL STOCK REQUESTS	1	160.38	
EFT46327	02/02/2023	BUNNINGS BUILDING SUPPLIES P/L	ESKY HYBRID JUG COOLER 5LT WITH BAG - I/N 0327171	1		2,043.39
INV 2182/998	22/12/2022	BUNNINGS BUILDING SUPPLIES P/L	ESKY HYBRID JUG COOLER 5LT WITH BAG - I/N 0327171	1	1,097.50	
INV 2182/003	09/01/2023	BUNNINGS BUILDING SUPPLIES P/L	SUPPLIES FOR SCHOOL HOLIDAY PROGRAM FOR 10/1/23	1	87.27	
INV 2182/003	16/01/2023	BUNNINGS BUILDING SUPPLIES P/L	KEY CUTTING	1	6.45	
INV 2182/004	17/01/2023	BUNNINGS BUILDING SUPPLIES P/L	27L LEMON TIDY BAGS	1	31.38	
INV 2182/002	18/01/2023	BUNNINGS BUILDING SUPPLIES P/L	KILLARA KITCHEN BIN REPLACEMENT	1	56.00	
INV 2182/005	19/01/2023	BUNNINGS BUILDING SUPPLIES P/L	PALLET OF GREY CEMENT	1	549.92	
INV 2182/003	19/01/2023	BUNNINGS BUILDING SUPPLIES P/L	PAINT TRAYS, ROLLERS, MORTER AND ACCESSORIES	1	122.35	
INV 2182/003	19/01/2023	BUNNINGS BUILDING SUPPLIES P/L	SPANNER SET	1	79.33	

**Ordinary Council Meeting Minutes
15 March 2023**

Attachment 13.4.1.1

Date: 01/03/2023
Time: 8:24:14AM

Shire of Northam

USER: Louise Harris
PAGE: 6 10

Cheque /EFT No	Date	Name	Invoice Description	Bank Code	INV Amount	Amount
INV 2182/003	19/01/2023	BUNNINGS BUILDING SUPPLIES P/L	AERORDROME. SUPPLY 1M CHAIN FOR GATE LOCK.	1	18.82	
INV 2182/003	19/01/2023	BUNNINGS BUILDING SUPPLIES P/L	CREDIT ISSUED - PVC GRATE HOLMAN	1	-5.63	
EFT46328	02/02/2023	CDG ENGINEERING	INSTALLATION OF PINTLE HOOK ON PN2104	1		4,125.00
INV 0000227027/01/2023		CDG ENGINEERING	INSTALLATION OF PINTLE HOOK ON PN2104	1	4,125.00	
EFT46329	02/02/2023	CENTRAL MOBILE MECHANICAL REPAIRS	PICK UP STEEL DRUM ROLLER WEDNESDAY AFTERNOON 25/01/23 FROM GRASS VALLEY NTH RD AND DROP OFF AT NORTHAM DEPOT	1		709.50
INV 0000428428/01/2023		CENTRAL MOBILE MECHANICAL REPAIRS	PICK UP STEEL DRUM ROLLER WEDNESDAY AFTERNOON 25/01/23 FROM GRASS VALLEY NTH RD AND DROP OFF AT NORTHAM DEPOT	1	709.50	
EFT46330	02/02/2023	CHARLES SERVICE COMPANY	C.202021-04. 4 X A WEEK - WEEKLY CLEAN - SHIRE OF NORTHAM TOILET FACILITIES - 19/12/2022 - 22/01/2023	1		13,625.32
INV 0003562222/01/2023		CHARLES SERVICE COMPANY	C.202021-04. 4 X A WEEK - WEEKLY CLEAN - SHIRE OF NORTHAM TOILET FACILITIES - 19/12/2022 - 22/01/2023	1	11,568.65	
INV 0003562322/01/2023		CHARLES SERVICE COMPANY	C 202021-04-VO1 - WEEKLY CLEANING FOR WUNDOWIE OVAL TOILETS 7 X A WEEK - 19/12/2022 - 22/01/2023	1	2,056.67	
EFT46331	02/02/2023	COMBINED TYRES PTY LTD	PN1612 REGO N.1709 - SUPPLY & FIT 225/80R17.5 MAXXIS MA265, INCLUDING DISPOSAL	1		902.00
INV INV-305024/01/2023		COMBINED TYRES PTY LTD	PN1612 REGO N.1709 - SUPPLY & FIT 225/80R17.5 MAXXIS MA265, INCLUDING DISPOSAL	1	902.00	
EFT46332	02/02/2023	DAMIAN'S PLUMBING	REPAIRS TO PRESSURE LINE FROM PUMP AT HENRY ST	1		1,177.00
INV 8551	29/01/2023	DAMIAN'S PLUMBING	REPAIR OF LEAK AT CLARKE STREET	1	572.00	
INV 8552	29/01/2023	DAMIAN'S PLUMBING	REPAIRS TO PRESSURE LINE FROM PUMP AT HENRY ST	1	605.00	
EFT46333	02/02/2023	G.S. BEVERIDGE & L.P. NOTTLE	VISITORS CENTRE. YEARLY OILING OF DECKING.	1		6,075.00
INV 15/1/23	15/01/2023	G.S. BEVERIDGE & L.P. NOTTLE	YOUTH PARK TOILET. PAINT ALL WALLS AFTER MULTIPLE GRAFFITI INSTANCES.	1	1,500.00	
INV 378	15/01/2023	G.S. BEVERIDGE & L.P. NOTTLE	WUNDOWIE POOL. REPAIR BROKEN POOL FENCING AS PER PHOTOS.	1	506.00	
INV 377	15/01/2023	G.S. BEVERIDGE & L.P. NOTTLE	WUNDOWIE DEPOT. REPLACE RUBBER SEAL TO BACK OF TOILET.	1	165.00	

**Ordinary Council Meeting Minutes
15 March 2023**

Attachment 13.4.1.1

Date: 01/03/2023
Time: 8:24:14AM

Shire of Northam

USER: Louise Harris
PAGE: 7 10

Cheque /EFT No	Date	Name	Invoice Description	Bank Code	INV Amount	Amount
INV 380	15/01/2023	G.S. BEVERIDGE & L.P. NOTTLE	VISITORS CENTRE. YEARLY OILING OF DECKING.	1	2,104.00	
INV 382	23/01/2023	G.S. BEVERIDGE & L.P. NOTTLE	VISITORS CENTER. PRESSURE SPRAY UNDERSIDE OF BUILDING TO GET RID OF COBWEBS.	1	1,800.00	
EFT46334	02/02/2023	GOODYEAR & DUNLOP TYRES (AUST) PTY LTD	PN1804 REGO N10759- PUNCTURE REPAIR & BALANCE	1		204.09
INV 6412920820/01/2023		GOODYEAR & DUNLOP TYRES (AUST) PTY LTD	PN1805 - PUNCTURE REPAIR & ROTATION OF TYRES	1	61.93	
INV 6412924224/01/2023		GOODYEAR & DUNLOP TYRES (AUST) PTY LTD	PN1804 REGO N10759- PUNCTURE REPAIR & BALANCE	1	142.16	
EFT46335	02/02/2023	GRAFTON ELECTRICS	REPAIR POOL VAC CORD	1		626.67
INV 9228	10/01/2023	GRAFTON ELECTRICS	TO FIX EXTERNAL WATERPARK START BUTTON.	1	208.67	
INV 9234	16/01/2023	GRAFTON ELECTRICS	REPAIR POOL VAC CORD	1	209.00	
INV 9250	25/01/2023	GRAFTON ELECTRICS	DIAGNOSE AND REPAIRS TO STORM WATER PUMP	1	209.00	
EFT46336	02/02/2023	INSTITUTE OF BUILDING TECHNOLOGY WA PTY LTD	CPCBS60121 - ADVANCED DIPLOMA OF BUILDING SURVEYANCE - JACOB SMITH	1		442.30
INV 0000831924/01/2023		INSTITUTE OF BUILDING TECHNOLOGY WA PTY LTD	CPCBS60121 - ADVANCED DIPLOMA OF BUILDING SURVEYANCE - JACOB SMITH	1	442.30	
EFT46337	02/02/2023	JH COMPUTER SERVICES PTY LTD	7NC - APC SMART-UPS LINE - INTERACTIVE UPS-3KVA/2.70KW - 2U RACK-MOUNTABLE - 3 HOUR RECHARGE / 7NC - 42U SERVER RACK CABINET (600MM X 1000MM) GLASS DOOR, 1X8-PORT PDU, 1X4-WAY FAN, 2X FIXED SHELVES - BLACK METAL CONSTRUCTION	1		5,555.00
INV 0000207529/01/2023		JH COMPUTER SERVICES PTY LTD	7NC - APC SMART-UPS LINE - INTERACTIVE UPS-3KVA/2.70KW - 2U RACK-MOUNTABLE - 3 HOUR RECHARGE / 7NC - 42U SERVER RACK CABINET (600MM X 1000MM) GLASS DOOR, 1X8-PORT PDU, 1X4-WAY FAN, 2X FIXED SHELVES - BLACK METAL CONSTRUCTION	1	5,555.00	
EFT46338	02/02/2023	JILLIAN TAYLOR	PAYMENT FOR WORKING ON 26 JANUARY 2023 ASSISTING WITH CITIZENSHIP CEREMONY	1		150.00
INV 001	31/01/2023	JILLIAN TAYLOR	PAYMENT FOR WORKING ON 26 JANUARY 2023 ASSISTING WITH CITIZENSHIP CEREMONY	1	150.00	

**Ordinary Council Meeting Minutes
15 March 2023**

Attachment 13.4.1.1

Date: 01/03/2023
Time: 8:24:14AM

Shire of Northam

USER: Louise Harris
PAGE: 8 10

Cheque /EFT No	Date	Name	Invoice Description	Bank Code	INV Amount	Amount
EFT46339	02/02/2023	KEITH BOASE	PURCHASE OF PLASTIC FUEL TANKS FOR ROLLER AT BERT HAWKE OVAL	1		44.99
INV SP 3001230/01/2023		KEITH BOASE	PURCHASE OF PLASTIC FUEL TANKS FOR ROLLER AT BERT HAWKE OVAL	1	44.99	
EFT46340	02/02/2023	KIM MARIE MURCUTT	REIMBURSE FOR KILLARA COLES GROCERIES - CARD DECLINED	1		190.49
INV 7646	31/01/2023	KIM MARIE MURCUTT	REIMBURSE FOR KILLARA COLES GROCERIES - CARD DECLINED	1	190.49	
EFT46341	02/02/2023	KLEENHEAT GAS	GAS FOR NORTHAM SWIMMING POOL HEATERS 03/01/2023	1		2,470.91
INV 2205427403/01/2023		KLEENHEAT GAS	GAS FOR NORTHAM SWIMMING POOL HEATERS 03/01/2023	1	2,470.91	
EFT46342	02/02/2023	MANDALAY TECHNOLOGIES PTY LTD	IMPLEMENTATION OF MANDALAY SYSTEM - 50% INITIAL PROGRESS PAYMENT	1		10,719.50
INV INV-690624/01/2023		MANDALAY TECHNOLOGIES PTY LTD	IMPLEMENTATION OF MANDALAY SYSTEM - HARDWARE	1	1,144.00	
INV INV-690724/01/2023		MANDALAY TECHNOLOGIES PTY LTD	IMPLEMENTATION OF MANDALAY SYSTEM - 50% INITIAL PROGRESS PAYMENT	1	10,120.00	
INV CN-6920 30/01/2023		MANDALAY TECHNOLOGIES PTY LTD	IMPLEMENTATION OF MANDALAY SYSTEM - HARDWARE - PARTIAL CREDIT ISSUED	1	-544.50	
EFT46343	02/02/2023	MCLEODS BARRISTERS & SOLICITORS	REVIEW OF BUILDING ORDERS - 39 INKPEN STREET	1		899.25
INV 127686 23/12/2022		MCLEODS BARRISTERS & SOLICITORS	REVIEW OF BUILDING ORDERS - 39 INKPEN STREET	1	899.25	
EFT46344	02/02/2023	MICHAEL KEVINO'SULLIVAN	SHIRE OF NORTHAM AUSTRALIA DAY 2023 PHOTOGRAPHY (1 DAY- 10HRS)	1		1,500.00
INV SON-00129/01/2023		MICHAEL KEVINO'SULLIVAN	SHIRE OF NORTHAM AUSTRALIA DAY 2023 PHOTOGRAPHY (1 DAY- 10HRS)	1	1,500.00	
EFT46345	02/02/2023	MINT CIVIL PTY LTD T/AS IMMACU SWEEP	C.201819-12 STREET SWEEPING & GULLY EDUCATION SERVICES (CLEANING TOWN ROADS) / FOOTPATH & VERGE SWEEPING OF CBD - 12/12/2022 - 18/12/2022	1		15,602.40
INV N3074 27/12/2022		MINT CIVIL PTY LTD T/AS IMMACU SWEEP	C.201819-12 STREET SWEEPING & GULLY EDUCATION SERVICES (CLEANING TOWN ROADS) / FOOTPATH & VERGE SWEEPING OF CBD - 12/12/2022 - 18/12/2022	1	3,900.60	

Ordinary Council Meeting Minutes
15 March 2023

Attachment 13.4.1.1

Date: 01/03/2023
Time: 8:24:14AM

Shire of Northam

USER: Louise Harris
PAGE: 9 10

Cheque /EFT No	Date	Name	Invoice Description	Bank Code	INV Amount	Amount
INV N3075	27/12/2022	MINT CIVIL PTY LTD T/AS IMMACU SWEEP	C.201819-12 STREET SWEEPING & GULLY EDUCATION SERVICES (CLEANING TOWN ROADS) / FOOTPATH & VERGE SWEEPING OF CBD - 19/12/2022 - 25/12/2022	1	3,900.60	
INV N3087	23/01/2023	MINT CIVIL PTY LTD T/AS IMMACU SWEEP	C.201819-12 STREET SWEEPING & GULLY EDUCATION SERVICES (CLEANING TOWN ROADS) / FOOTPATH & VERGE SWEEPING OF CBD - 9/1/2023 - 15/1/2023	1	3,900.60	
INV N3088	23/01/2023	MINT CIVIL PTY LTD T/AS IMMACU SWEEP	C.201819-12 STREET SWEEPING & GULLY EDUCATION SERVICES (CLEANING TOWN ROADS) / FOOTPATH & VERGE SWEEPING OF CBD - 16/1/2023 - 22/01/2023	1	3,900.60	
EFT46346	02/02/2023	NAVMAN WIRELESS PTY LTD	SUBSCRIPTION SERVICE FEES FOR NAVTRAC SYSTEM FOR DEPOT 19 UNITS @ \$44 INC GST A UNIT - 15/1/2023 - 14/2/2023	1		1,311.59
INV 9271744605/01/2023		NAVMAN WIRELESS PTY LTD	MONTHLY SATELITE SERVICE FOR NAVTRAC SYSTEM FOR DEPOT 13 UNITS @ \$32.95 INC GST A UNIT - 05/01/2023 - 04/02/2023	1	417.67	
INV 9272439615/01/2023		NAVMAN WIRELESS PTY LTD	SUBSCRIPTION SERVICE FEES FOR NAVTRAC SYSTEM FOR DEPOT 19 UNITS @ \$44 INC GST A UNIT - 15/1/2023 - 14/2/2023	1	893.92	
EFT46347	02/02/2023	NICOLE HAMPTON	PAIGE CRIDDLE - LEAVING GIFT	1		126.80
INV 5339	21/01/2023	NICOLE HAMPTON	PAIGE CRIDDLE - LEAVING GIFT	1	126.80	
EFT46348	02/02/2023	NORTHAM & DISTRICTS LITTLE ATHLETICS	2022-23 COMMUNITY DEVELOPMENT GRANT PAYMENT. INSTALMENT 1	1		18,000.00
INV 113	10/01/2023	NORTHAM & DISTRICTS LITTLE ATHLETICS	2022-23 COMMUNITY DEVELOPMENT GRANT PAYMENT. INSTALMENT 1	1	18,000.00	
EFT46349	02/02/2023	NORTHAM BETTA HOME LIVING	ASUS 15.6" i5 - LAPTOP - JAIME & IAN	1		2,948.00
INV 2001005003/01/2023		NORTHAM BETTA HOME LIVING	ASUS 15.6" i5 - LAPTOP - JAIME & IAN	1	2,398.00	
INV 2001005004/01/2023		NORTHAM BETTA HOME LIVING	CHEST FREEZER - REC CENTRE	1	550.00	
EFT46350	02/02/2023	NORTHAM CHAMBER OF COMMERCE	SHIRE INCLUSION IN NORTHAM ADVERTISER- FULL PAGE- FEBRUARY 2023	1		440.00
INV 1058	24/01/2023	NORTHAM CHAMBER OF COMMERCE	SHIRE INCLUSION IN NORTHAM ADVERTISER- FULL PAGE- FEBRUARY 2023	1	440.00	

**Ordinary Council Meeting Minutes
15 March 2023**

Attachment 13.4.1.1

Date: 01/03/2023
Time: 8:24:14AM

Shire of Northam

USER: Louise Harris
PAGE: 10 10

Cheque /EFT No	Date	Name	Invoice Description	Bank Code	INV Amount	Amount
EFT46351	02/02/2023	NORTHAM FEED & HIRE	SWAN FOOD & OTHER MISCELLANEOUS ITEMS JANUARY 2023	1		341.50
INV 0000464917/01/2023		NORTHAM FEED & HIRE	SWAN FOOD & OTHER MISCELLANEOUS ITEMS JANUARY 2023	1	52.50	
INV 0000465018/01/2023		NORTHAM FEED & HIRE	SWAN FOOD & OTHER MISCELLANEOUS ITEMS JANUARY 2023	1	129.00	
INV 0000465820/01/2023		NORTHAM FEED & HIRE	SWAN FOOD & OTHER MISCELLANEOUS ITEMS JANUARY 2023	1	46.00	
INV 0000465923/01/2023		NORTHAM FEED & HIRE	SWAN FOOD & OTHER MISCELLANEOUS ITEMS JANUARY 2023	1	35.00	
INV 0000466325/01/2023		NORTHAM FEED & HIRE	SWAN FOOD & OTHER MISCELLANEOUS ITEMS JANUARY 2023	1	22.00	
INV 0000466427/01/2023		NORTHAM FEED & HIRE	SWAN FOOD & OTHER MISCELLANEOUS ITEMS JANUARY 2023	1	57.00	
EFT46352	02/02/2023	NORTHAM TOWING SERVICE	1TVZ247 - TRI AXLE TRAILER TO BE TRANSPORTED FROM SHIRE DEPOT 12.1.2023 TO UNIVERSAL TRAILERS, 78-80 BEERCROFT ROAD GOOMALLING	1		550.00
INV 212099	17/01/2023	NORTHAM TOWING SERVICE	1TVZ247 - TRI AXLE TRAILER TO BE TRANSPORTED FROM SHIRE DEPOT 12.1.2023 TO UNIVERSAL TRAILERS, 78-80 BEERCROFT ROAD GOOMALLING	1	550.00	
EFT46353	02/02/2023	NORTHSTAR ASSET PTY LTD	COPY RIGHT FEE-AUSTRALIA DAY 2023 MOVIE NIGHT-MINIONS RISE OF GRU	1		440.00
INV 0001225419/01/2023		NORTHSTAR ASSET PTY LTD	COPY RIGHT FEE-AUSTRALIA DAY 2023 MOVIE NIGHT-MINIONS RISE OF GRU	1	440.00	
EFT46354	02/02/2023	OCTAGON LIFTS PTY LTD	NORTHAM LIBRARY. ATTEND SITE AND RECTIFY LIFT ISSUE, DOOR NOT OPENING WHEN AT TOP FLOOR.	1		702.90
INV 58977	20/01/2023	OCTAGON LIFTS PTY LTD	NORTHAM LIBRARY. ATTEND SITE AND RECTIFY LIFT ISSUE, DOOR NOT OPENING WHEN AT TOP FLOOR.	1	702.90	
EFT46355	02/02/2023	OXTER SERVICES	BURIAL DATE 21/12/2022: NEW GRAVE FOR THE BURIAL OF ERNEST POMATE / BURIAL DATE 20/12/2022: NEW GRAVE FOR THE BURIAL OF ASHLY COTTERILL	1		4,136.00
INV 26764	22/12/2022	OXTER SERVICES	BURIAL DATE 21/12/2022: NEW GRAVE FOR THE BURIAL OF ERNEST POMATE / BURIAL DATE 20/12/2022: NEW GRAVE FOR THE BURIAL OF ASHLY COTTERILL	1	2,134.00	

**Ordinary Council Meeting Minutes
15 March 2023**

Attachment 13.4.1.1

Date: 01/03/2023
Time: 8:24:14AM

Shire of Northam

USER: Louise Harris
PAGE: 11 10

Cheque /EFT No	Date	Name	Invoice Description	Bank Code	INV Amount	Amount
INV 26770	22/12/2022	OXTER SERVICES	BURIAL DATE 22/12/2022: REOPEN GRAVE FOR THE BURIAL OF THERESA FICE	1	1,001.00	
INV 26816	18/01/2023	OXTER SERVICES	BURIAL DATE 18/01/2023 NEW GRAVE FOR THE BURIAL OF ANNA RAKOWSKI	1	1,001.00	
EFT46356	02/02/2023	PFD FOOD SERVICES PTY LTD	STOCK FOR AQUATIC FACILITY KIOSK	1		3,509.80
INV LF60731911/01/2023		PFD FOOD SERVICES PTY LTD	STOCK FOR AQUATIC FACILITY KIOSK	1	969.35	
INV LF60732011/01/2023		PFD FOOD SERVICES PTYLTD	PFD KIOSK STOCK - FOR AQUATIC FACILITY - FRIES & MILO ICE CREAMS	1	417.35	
INV LF67535218/01/2023		PFD FOOD SERVICES PTYLTD	STOCK FOR AQUATIC FACILITY KIOSK	1	935.70	
INV LF74724725/01/2023		PFD FOOD SERVICES PTY LTD	STOCK FOR AQUATIC FACILITY KIOSK	1	1,187.40	
EFT46357	02/02/2023	POOLSHOP ONLINE PTY LTD	WATER TESTING SUPPLIES FOR AQUATIC FACILITY	1		1,582.00
INV INV-134030/01/2023		POOLSHOP ONLINE PTY LTD	WATER TESTING SUPPLIES FOR AQUATIC FACILITY	1	1,582.00	
EFT46358	02/02/2023	PROFESSIONALLOCKSERVICE	NORTHAM DEPOT NEW ADMIN BUILDING. CHANGE OUT LOCK CYLINDERS TO SON MASTER KEY SYSTEM AND ADD DOOR CLOSERS AS DISCUSSED ON SITE, AS PER QUOTE.	1		4,258.10
INV 0010844828/01/2023		PROFESSIONALLOCKSERVICE	NORTHAM DEPOT NEW ADMIN BUILDING. CHANGE OUT LOCK CYLINDERS TO SON MASTER KEY SYSTEM AND ADD DOOR CLOSERS AS DISCUSSED ON SITE, AS PER QUOTE.	1	4,258.10	
EFT46359	02/02/2023	RED DOT STORE	STRING & GLITTER	1		29.73
INV 7467397 20/01/2023		RED DOT STORE	STRING & GLITTER	1	27.00	
INV 7467414 20/01/2023		RED DOT STORE	MASKING TAPE	1	2.73	
EFT46360	02/02/2023	REGIONAL PHYSIOTHERAPY & SPORTS INJURY CLINIC & IN BALANCE FITNESS	SENIOR SPORTS FUNDING - VALERIE HORSFIELD	1		99.00
INV 0080545 25/01/2023		REGIONAL PHYSIOTHERAPY & SPORTS INJURY CLINIC & IN BALANCE FITNESS	SENIOR SPORTS FUNDING - VALERIE HORSFIELD	1	99.00	
EFT46361	02/02/2023	RONLIEEH PTY LTD T/AS ALL PARTS WA	SOCKET EXTENSION BAR	1		212.49
INV SI-00007531/01/2023		RONLIEEH PTY LTD T/AS ALL PARTS WA	SOCKET EXTENSION BAR	1	212.49	

**Ordinary Council Meeting Minutes
15 March 2023**

Attachment 13.4.1.1

Date: 01/03/2023
Time: 8:24:14AM

Shire of Northam

USER: Louise Harris
PAGE: 12 10

Cheque /EFT No	Date	Name	Invoice Description	Bank Code	INV Amount	Amount
EFT46362	02/02/2023	SPECIALISED TREESERVICE	GRASS VALLEY TOWNSITE STREET TREES PRUNING AS PER C.201819-09	1		3,044.25
INV 4023	27/01/2023	SPECIALISED TREESERVICE	GRASS VALLEY TOWNSITE STREET TREES PRUNING AS PER C.201819-09	1	3,044.25	
EFT46363	02/02/2023	ST JOHN AMBULANCE AUSTRALIA (FIRST AID COURSE)	APPLIED FIRST AID COURSE MADDISON DOUGLAS	1		160.00
INV FAINV0112/01/2023		ST JOHN AMBULANCE AUSTRALIA (FIRST AID COURSE)	APPLIED FIRST AID COURSEMADDISON DOUGLAS	1	160.00	
EFT46364	02/02/2023	SYNERGY	357549690 KILLARA DAYCARE CENTRE - 16/12/2022 to 18/01/2023	1		2,726.21
INV 3358209418/01/2023		SYNERGY	335820940 CREATE 298 - 22/12/2022 to 17/01/2023		564.97	
INV 3616702519/01/2023		SYNERGY	361670250 NORTHAM LIBRARY - 16/12/2022 to 18/01/2023		376.54	
INV 3575496919/01/2023		SYNERGY	357549690 KILLARA DAYCARE CENTRE - 16/12/2022 to 18/01/2023		756.27	
INV 3613331820/01/2023		SYNERGY	361333180 SUSPENSION BRIDGE LIGHTING - 15/11/2022 to 17/01/2023		301.27	
INV 3577031820/01/2023		SYNERGY	357703180 STORMWATER DAM PUMP - 15/11/2022 to 18/01/2023		165.47	
INV 3575473320/01/2023		SYNERGY	357547330 APEX PARK TOILETS - 15/11/2022 to 18/01/2023		161.59	
INV 3805238627/01/2023		SYNERGY	380523860 OLD QUARRY RD REFUSE SITE - RUBBISH DEPOT AT OLD QUARRY RD NORTHAM LOT 422 RES 26840 - 24/11/2022 to 25/01/2023		400.10	
EFT46365	02/02/2023	AVON VALLEY NISSAN & MITSUBISHI AVN NORTHAM PTY LTD T/AS	MR TRITON GLX 2.4L DIESEL 6A/T 4X4 SC CABSHISSIS WHITE. SUPPER FIT CANVAS SEAT COVERS, SUPPLY AND FIT TOW BAR, TRANSFER TOOL BOX, BEACONS, UHF, WORK LIGHTS & LIGHTBAR, PIT INSPECTION, SUPPLY AND FIT FLOOR MAT SET RUBBER, WINDOW TINT. AS PER QUOTE 7974	1		29,636.70
INV 7974	24/01/2023	AVON VALLEY NISSAN & MITSUBISHI AVN NORTHAM PTY LTD T/AS	MR TRITON GLX 2.4L DIESEL 6A/T 4X4 SC CABSHISSIS WHITE. SUPPER FIT CANVAS SEAT COVERS, SUPPLY AND FIT TOW BAR, TRANSFER TOOL BOX, BEACONS, UHF, WORK LIGHTS & LIGHTBAR, PIT INSPECTION, SUPPLY AND FIT FLOOR MAT SET RUBBER, WINDOW TINT. AS PER QUOTE 7974	1	29,636.70	

**Ordinary Council Meeting Minutes
15 March 2023**

Attachment 13.4.1.1

Date: 01/03/2023
Time: 8:24:14AM

Shire of Northam

USER: Louise Harris
PAGE: 13 10

Cheque /EFT No	Date	Name	Invoice Description	Bank Code	INV Amount	Amount
EFT46366	02/02/2023	TALIS CONSULTANTS PTY LTD	C.202021-24 - PROVISION OF CONSULTANCY SERVICES FOR THE PERIOD ENDING 30 NOVEMBER 2022. STORM EVENT 2-4 MARCH 2021 - AGRN962	1		2,763.75
INV 27009	30/11/2022	TALIS CONSULTANTS PTY LTD	C.202021-24 - PROVISION OF CONSULTANCY SERVICES FOR THE PERIOD ENDING 30 NOVEMBER 2022. STORM EVENT 2-4 MARCH 2021 - AGRN962	1	2,763.75	
EFT46367	02/02/2023	TELSTRA LIMITED	TELSTRA CHARGES - DECEMBER 2022 - ADMIN INTERNET	1		13,782.99
INV 2726009204/01/2023		TELSTRA LIMITED	TELSTRA CHARGES - DECEMBER 2022 - HARVEST BAN	1	3,932.64	
INV 2726009010/01/2023		TELSTRA LIMITED	TELSTRA CHARGES - DECEMBER 2022 - ADMIN / FINANCE / BKB / ENGINEERING / REC CENTRE	1	145.45	
INV 2726008910/01/2023		TELSTRA LIMITED	TELSTRA CHARGES - DECEMBER 2022 - COUNCILLOR IPADS / ADMIN / FINANCE / CESM / BUSHFIRES / RANGERS / CCTV / HEALTH / KILLARA / LANDFILL / PLANNING / WUNDOWIE POOL / NORTHAM LIBRARY / CREATE 298 / BKB / ENGINEERING / BUILDING / VC / REC CENTRE / SES	1	2,874.37	
INV 2258398814/01/2023		TELSTRA LIMITED	TELSTRA CHARGES - DECEMBER 2022 - ADMIN INTERNET	1	5,789.12	
INV 9026075017/01/2023		TELSTRA LIMITED	TELSTRA CHARGES - DECEMBER 2022 - ADMIN / FINANCE / ADMIN INTERNET / HARVEST BAN / LANDFILL / WUNDOWIE POOL / NORTHAM LIBRARY / WUNDOWIE LIBRARY / CREATE 298 / ENGINEERING / LANDFILL INTERNET / REC CENTRE / CESM / BUSHFIRES	1	1,041.41	
EFT46368	02/02/2023	THE PRINT SHOP BUNBURY	BOW BANNER - DOUBLE SIDED SMALL	1		1,538.90
INV 1553337	11/01/2023	THE PRINT SHOP BUNBURY	AUSTRALIA DAY POSTERS 235GSM	1	137.50	
INV 1554044	16/01/2023	THE PRINT SHOP BUNBURY	BOW BANNER - DOUBLE SIDED SMALL	1	720.50	
INV 1554980	20/01/2023	THE PRINT SHOP BUNBURY	AUSTRALIA DAY POLYESTER BUNTING 23 X 30	1	434.50	
INV 1555906	25/01/2023	THE PRINT SHOP BUNBURY	BUMPER STICKERS NA07MISC MONOMERIC ADHESIVE VINYL PHOTO WITH BALLOONS	1	246.40	
EFT46369	02/02/2023	TIM SAMUAL EDMONDS	RATES CREDIT REFUND FOR ASSESSMENT A451	1		250.32
INV A451	31/01/2023	TIM SAMUAL EDMONDS	RATES CREDIT REFUND FOR ASSESSMENT A451		250.32	

**Ordinary Council Meeting Minutes
15 March 2023**

Attachment 13.4.1.1

Date: 01/03/2023
Time: 8:24:14AM

Shire of Northam

USER: Louise Harris
PAGE: 14 10

Cheque /EFT No	Date	Name	Invoice Description	Bank Code	INV Amount	Amount
EFT46370	02/02/2023	TUTT BRYANT EQUIPMENT PTY LTD	PN1502 - BOMAG ROLLER - 05720305 OIL DIP STICK	1		213.96
INV 0084771423/01/2023		TUTT BRYANT EQUIPMENT PTY LTD	PN1502 - BOMAG ROLLER - 05720305 OILDIP STICK	1	213.96	
EFT46371	02/02/2023	TYRECYCLE PTY LTD	PICK UP AND RECYCLE TYRES - OLD QUARRY LANDFILL AND TRANSFER STATION	1		2,360.70
INV 1049471	17/01/2023	TYRECYCLE PTY LTD	PICK UP AND RECYCLE TYRES - OLD QUARRY LANDFILL AND TRANSFER STATION	1	2,360.70	
EFT46372	02/02/2023	UNITED SCANNING SERVICES PTY LTD	SERVICE LOCATING AND NON-DESTRUCTIVE EXCAVATION - GREY STREET, NORTHAM	1		4,345.00
INV 230120_120/01/2023		UNITED SCANNING SERVICES PTY LTD	SERVICE LOCATING AND NON-DESTRUCTIVE EXCAVATION - GREY STREET, NORTHAM	1	4,345.00	
EFT46373	02/02/2023	WA CONTRACT RANGER SERVICES	C.201920-09 - MANAGMENT OF SHIRE OF NORTHAM DOG IMPOUND FACILITY / C.201920-09 - AFTER HOURS CALL MONITERING SERVICE 9/1/2023 - 22/1/2023	1		1,320.00
INV 0000448226/01/2023		WA CONTRACT RANGER SERVICES	C.201920-09 - MANAGMENT OF SHIRE OF NORTHAM DOG IMPOUND FACILITY / C.201920-09 - AFTER HOURS CALL MONITERING SERVICE 9/1/2023 - 22/1/2023	1	1,320.00	
EFT46374	02/02/2023	WA DISTRIBUTORS PTY LTD	NORTHAM AQUATIC FACILITY - KIOSK SUPPLIES	1		622.55
INV 801725	12/01/2023	WA DISTRIBUTORS PTY LTD	NORTHAM AQUATIC FACILITY - KIOSK SUPPLIES	1	622.55	
EFT46375	02/02/2023	WA RETICULATION SUPPLIES	SOL-SD-DC-2E SD SYSTEMS PROGRAMABLE COIL (BERMAD) AS PER QUOTE N2829	1		1,697.20
INV N2829	18/01/2023	WA RETICULATION SUPPLIES	SOL-SD-DC-2E SD SYSTEMS PROGRAMABLE COIL (BERMAD) AS PER QUOTE N2829	1	1,463.30	
INV N2652	20/01/2023	WA RETICULATION SUPPLIES	SOL-114401-H DIAPHRAGM ASSEMBLY IRRITROL 216	1	233.90	
EFT46376	02/02/2023	WESTWIDE AUTO ELECTRICS AND AIR CONDITIONING	QUOTE & REPAIRS TO 3X UNIDEN TWO WAY RADIOS	1		97.00
INV INV-141412/01/2023		WESTWIDE AUTO ELECTRICS AND AIR CONDITIONING	QUOTE & REPAIRS TO 3X UNIDEN TWO WAY RADIOS	1	97.00	
EFT46377	02/02/2023	WHEATBELT ICECREAM TIME / COFFEE TIME	AUSTRALIA DAY 2023- MOVIE NIGHT-SUPPLY OF 150 SINGLE SERVE ICECREAMS +150 SERVES WATER & COOLDRINK	1		1,500.00

Ordinary Council Meeting Minutes
15 March 2023

Attachment 13.4.1.1

Date: 01/03/2023
Time: 8:24:14AM

Shire of Northam

USER: Louise Harris
PAGE: 15 10

Cheque /EFT No	Date	Name	Invoice Description	Bank Code	INV Amount	Amount
INV INV-040318/01/2023		WHEATBELT ICECREAM TIME / COFFEE TIME	AUSTRALIA DAY 2023- MOVIE NIGHT-SUPPLY OF 150 SINGLE SERVE ICECREAMS +150 SERVES WATER & COOLDRINK	1	1,500.00	
EFT46378	02/02/2023	WHEATBELT NATURAL RESOURCE MANAGEMENT	PROVIDE A RANGER TEAM TO UNDERTAKE ROUTINE WHIPPER SNIPPING ALONG EASEMENT DRAIN ON GLEESON HILL RD BAKERS HILL.	1		770.00
INV 0030144216/01/2023		WHEATBELT NATURAL RESOURCE MANAGEMENT	PROVIDE A RANGER TEAM TO UNDERTAKE ROUTINE WHIPPER SNIPPING ALONG EASEMENT DRAIN ON GLEESON HILL RD BAKERS HILL.	1	770.00	
EFT46379	02/02/2023	WHEATBELT OFFICE & BUSINESS MACHINES / COUNTRY COPIERS - GARDNER T/AS	PROMOTIONAL INSERTS FOR BACK TO SCHOOL GIVEAWAYS - 60 BAGS	1		80.00
INV 691	20/01/2023	WHEATBELT OFFICE & BUSINESS MACHINES / COUNTRY COPIERS - GARDNER T/AS	PROMOTIONAL INSERTS FOR BACK TO SCHOOL GIVEAWAYS - 60 BAGS	1	80.00	
EFT46380	02/02/2023	WOODLANDS DISTRIBUTORS PTYLTD	EPI-OXO300 - DEGRADABLE SINGLE/GUSSETT BAG - 5 x CARTONS, 300 BAGS PER ROLL	1		632.50
INV 5605	20/01/2023	WOODLANDS DISTRIBUTORS PTYLTD	EPI-OXO300 - DEGRADABLE SINGLE/GUSSETT BAG - 5 x CARTONS, 300 BAGS PER ROLL	1	632.50	
EFT46381	02/02/2023	YELLOW CITRINE PTYLTD	6M PARK VIEW CINEMA + 50 x BEAN BAG HIRE. INCLUDING DELIVERY AND COLLECTION AND TECH ON SITE FOR DURATION OF FILM. PUBLIC HOLIDAY SURCHARGE	1		3,300.00
INV INV-283920/12/2022		YELLOW CITRINE PTYLTD	6M PARK VIEW CINEMA + 50 x BEAN BAG HIRE. INCLUDING DELIVERY AND COLLECTION AND TECH ON SITE FOR DURATION OF FILM. PUBLIC HOLIDAY SURCHARGE	1	3,300.00	
EFT46382	03/02/2023	AUSTRALIAN SERVICES UNION	PAYROLL DEDUCTIONS	1		129.50
INV DEDUCT31/01/2023		AUSTRALIAN SERVICES UNION	PAYROLL DEDUCTIONS		129.50	
EFT46383	03/02/2023	CHILD SUPPORT AGENCY	PAYROLL DEDUCTIONS	1		485.44
INV DEDUCT31/01/2023		CHILD SUPPORT AGENCY	PAYROLL DEDUCTIONS		485.44	

Ordinary Council Meeting Minutes
15 March 2023

Attachment 13.4.1.1

Date: 01/03/2023
Time: 8:24:14AM

Shire of Northam

USER: Louise Harris
PAGE: 16 10

Cheque /EFT No	Date	Name	Invoice Description	Bank Code	INV Amount	Amount
EFT46384	03/02/2023	EASIFLEET	PAYROLL DEDUCTIONS	1		1,853.35
INV DEDUCT31/01/2023		EASIFLEET	PAYROLL DEDUCTIONS		1,054.26	
INV DEDUCT31/01/2023		EASIFLEET	PAYROLL DEDUCTIONS		799.09	
EFT46385	03/02/2023	WCP CIVIL PTY LTD	PAVEMENT CONSTRUCTION, PRIMER SEAL, ASPHALT AND LINE MARKING OF WELLINGTON STREET, NORTHAM AS PER CONTRACT C.202122-06.	1		242,730.45
INV 28228	13/01/2023	WCP CIVIL PTY LTD	PAVEMENT CONSTRUCTION, PRIMER SEAL, ASPHALT AND LINE MARKING OF WELLINGTON STREET, NORTHAM AS PER CONTRACT C.202122-06.	1	236,619.40	
INV 28228	13/01/2023	WCP CIVIL PTY LTD	VO3 - C.202122-06 ROAD CONSTRUCTION PACKAGE - SUBGRADE STABILISATION DEPTH INCREASED TO 160MM FROM 100MM, STABILISATION WITH 2.5% HYDRATED LIME	1	6,111.05	
EFT46386	07/02/2023	ATTILA JOHN MENCSELYI	COUNCILLOR PAYMENTS FOR JANUARY 2023	1		1,947.17
INV JANUAR31/01/2023		ATTILA JOHN MENCSELYI	COUNCILLOR PAYMENTS FOR JANUARY 2023	1	1,947.17	
EFT46387	07/02/2023	BROOKLANDS SUPER PTY LTD	COUNCILLOR PAYMENTS FOR JANUARY 2023	1		500.00
INV JANUAR31/01/2023		BROOKLANDS SUPER PTY LTD	COUNCILLOR PAYMENTS FOR JANUARY 2023	1	500.00	
EFT46388	07/02/2023	CHRISTOPHER ANTONIO	COUNCILLOR PAYMENTS FOR JANUARY 2023	1		5,594.96
INV JANUAR31/01/2023		CHRISTOPHER ANTONIO	COUNCILLOR PAYMENTS FOR JANUARY 2023	1	5,594.96	
EFT46389	07/02/2023	DAVID JAMES GALLOWAY	COUNCILLOR PAYMENTS FOR JANUARY 2023	1		1,905.73
INV JANUAR31/01/2023		DAVID JAMES GALLOWAY	COUNCILLOR PAYMENTS FOR JANUARY 2023	1	1,905.73	
EFT46390	07/02/2023	DESMOND ARNOLD HUGHES	COUNCILLOR PAYMENTS FOR JANUARY 2023	1		1,905.73
INV JANUAR31/01/2023		DESMOND ARNOLD HUGHES	COUNCILLOR PAYMENTS FOR JANUARY 2023	1	1,905.73	
EFT46391	07/02/2023	HAYDEN JOHN APPLETON	COUNCILLOR PAYMENTS FOR JANUARY 2023	1		1,905.73
INV JANUAR31/01/2023		HAYDEN JOHN APPLETON	COUNCILLOR PAYMENTS FOR JANUARY 2023	1	1,905.73	

**Ordinary Council Meeting Minutes
15 March 2023**

Attachment 13.4.1.1

Date: 01/03/2023
Time: 8:24:14AM

Shire of Northam

USER: Louise Harris
PAGE: 17 10

Cheque /EFT No	Date	Name	Invoice Description	Bank Code	INV Amount	Amount
EFT46392	07/02/2023	JULIE ELLEN GREENFIELD WILLIAMS	COUNCILLOR PAYMENTS FOR JANUARY 2023	1		1,905.73
INV JANUAR31/01/2023		JULIE ELLEN GREENFIELD WILLIAMS	COUNCILLOR PAYMENTS FOR JANUARY 2023	1	1,905.73	
EFT46393	07/02/2023	MARIA IRENE GIRAK	COUNCILLOR PAYMENTS FOR JANUARY 2023	1		1,905.73
INV JANUAR31/01/2023		MARIA IRENE GIRAK	COUNCILLOR PAYMENTS FOR JANUARY 2023	1	1,905.73	
EFT46394	07/02/2023	MICHAEL PATRICK RYAN	COUNCILLOR PAYMENTS FOR JANUARY 2023	1		2,843.23
INV JANUAR31/01/2023		MICHAEL PATRICK RYAN	COUNCILLOR PAYMENTS FOR JANUARY 2023	1	2,843.23	
EFT46395	07/02/2023	ROBERT WAYNE TINETTI	COUNCILLOR PAYMENTS FOR JANUARY 2023	1		1,905.73
INV JANUAR31/01/2023		ROBERT WAYNE TINETTI	COUNCILLOR PAYMENTS FOR JANUARY 2023	1	1,905.73	
EFT46396	09/02/2023	A COUNTRY PRACTICE	CONSULTATION AND EUTHANASIA	1		402.00
INV ACP167309/01/2023		A COUNTRY PRACTICE	CONSULTATION AND EUTHANASIA	1	402.00	
EFT46397	09/02/2023	ADVANCED TRAFFIC MANAGEMENT (WA) PTY LTD	3XTC 2XVEHICLE - WEEKDAY DAY SHIFT 0-8 PER HR / TMP - WORKSITE 85 GOOMALLING RD	1		708.95
INV 0016341830/01/2023		ADVANCED TRAFFIC MANAGEMENT (WA) PTY LTD	3XTC 2XVEHICLE - WEEKDAY DAY SHIFT 0-8 PER HR / TMP - WORKSITE 85 GOOMALLING RD	1	708.95	
EFT46398	09/02/2023	AFGRI EQUIPMENT AUSTRALIA PTY LTD	HYDRAULIC LINE FOR PERUZZO MOWER	1		151.77
INV 2681222 27/01/2023		AFGRI EQUIPMENT AUSTRALIA PTY LTD	HYDRAULIC LINE FOR PERUZZO MOWER	1	151.77	
EFT46399	09/02/2023	AGWEST MACHINERY - GREYMACH PTY LTD T/AS	HEDGE TRIMMER	1		386.10
INV 341888 17/01/2023		AGWEST MACHINERY - GREYMACH PTY LTD T/AS	HEDGE TRIMMER	1	386.10	
EFT46400	09/02/2023	AMPAC DEBT RECOVERY (WA)P/L	DEBT RECOVERY FOR PERIOD ENDING JANUARY 2023 - INVOICE 92693	1		426.25
INV 92693 31/01/2023		AMPAC DEBT RECOVERY (WA)P/L	DEBT RECOVERY FOR PERIOD ENDING JANUARY 2023 - INVOICE 92693	1	426.25	
EFT46401	09/02/2023	ANDY'S PLUMBING SERVICE	BERNARD PARK TOILETS. REPLACE CISTERN WITH PUSH BUTTON IN FEMALES TOILET.	1		2,574.00

**Ordinary Council Meeting Minutes
15 March 2023**

Attachment 13.4.1.1

Date: 01/03/2023
Time: 8:24:14AM

Shire of Northam

USER: Louise Harris
PAGE: 18 10

Cheque /EFT No	Date	Name	Invoice Description	Bank Code	INV Amount	Amount
INV A19481	27/01/2023	ANDY'S PLUMBINGSERVICE	BERNARD PARK TOILETS. REPLACE CISTERN WITH PUSH BUTTON IN FEMALES TOILET.	1	1,100.00	
INV A19483	27/01/2023	ANDY'S PLUMBINGSERVICE	BAKERS HILL HOOPER PARK TOILET. REPAIR MALE TOILET NOT FLUSHING.	1	940.50	
INV A19480	27/01/2023	ANDY'S PLUMBING SERVICE	PEEL TERRACE DUMP POINT. UNBLOCK AND CLEAN OUT AS IT IS BLOCKED.	1	533.50	
EFT46402	09/02/2023	AUSTRALIAN TAXATION OFFICE - PAYG	PAYG FOR PAY WEEK ENDING 31/01/2023	1		74,442.97
INV PAYG 3103/02/2023		AUSTRALIAN TAXATION OFFICE - PAYG	PAYG FOR PAY WEEK ENDING 31/01/2023	1	74,442.97	
EFT46403	09/02/2023	AVON SERVICESPECIALISTS	PN1710 - N79 - PLEASE CONDUCT 132000KM SERVICE, PLEASE ADVISE AS SOON AS READY FOR COLLECTION	1		429.10
INV 24842	12/01/2023	AVON SERVICESPECIALISTS	PN1710 - N79 - PLEASE CONDUCT 132000KM SERVICE, PLEASE ADVISE AS SOON AS READY FOR COLLECTION	1	429.10	
EFT46404	09/02/2023	AVON VALLEY GLASS	SUPPLY AND INSTALL FRONT WINDSCREEN IN 2016 TOYOTA LANDCRUISER UTE INCLUDES NEW RUBBER MOULDING	1		530.00
INV 0001314523/01/2023		AVON VALLEY GLASS	SUPPLY AND INSTALL FRONT WINDSCREEN IN 2016 TOYOTA LANDCRUISER UTE INCLUDES NEW RUBBER MOULDING	1	530.00	
EFT46405	09/02/2023	AVON WASTE	C.202122-04 MANAGEMENT OF OLD QUARRY ROAD LANFILL FACILITY / MANAGEMENT OF WASTETRANSFER STATION & TIP SHOP / MANAGEMENT OF INKPEN LANDFILL FACILITY - JANUARY 2023	1		143,531.07
INV 54286	27/01/2023	AVON WASTE	DOMESTIC RUBBISH / COMMERCIAL RUBBISH PER FORTNIGHT 27/01/2023	1	46,572.00	
INV 0005428731/01/2023		AVON WASTE	C.202122-04 MANAGEMENT OF OLD QUARRY ROAD LANFILL FACILITY / MANAGEMENT OF WASTETRANSFER STATION & TIP SHOP / MANAGEMENT OF INKPEN LANDFILL FACILITY - JANUARY 2023	1	96,959.07	
EFT46406	09/02/2023	BAILEYS FERTILISERS	SOIL SAMPLING	1		962.50
INV 35924	03/02/2023	BAILEYS FERTILISERS	SOIL SAMPLING	1	962.50	
EFT46407	09/02/2023	BLACKWELL PLUMBING AND GAS PTY LTD	PLUMBING CALL OUT TO NORTHAM AQUATIC FACILITY	1		783.20

Ordinary Council Meeting Minutes
15 March 2023

Attachment 13.4.1.1

Date: 01/03/2023
Time: 8:24:14AM

Shire of Northam

USER: Louise Harris
PAGE: 19 10

Cheque /EFT No	Date	Name	Invoice Description	Bank Code	INV Amount	Amount
INV INV-276631/01/2023		BLACKWELL PLUMBING AND GAS PTY LTD	PLUMBING CALL OUT TO NORTHAM AQUATIC FACILITY	1	783.20	
EFT46408	09/02/2023	BOLINDA PUBLISHING PTY LTD	LARGE PRINT BOOKS FOR LOCAL STOCK REQUESTS	1		64.35
INV 282176	17/01/2023	BOLINDA PUBLISHING PTY LTD	LARGE PRINT BOOKS FOR LOCAL STOCK REQUESTS	1	64.35	
EFT46409	09/02/2023	BUNNINGS BUILDING SUPPLIES P/L	SIKAFLEX	1		388.87
INV 2182/003	19/01/2023	BUNNINGS BUILDING SUPPLIES P/L	26X100CM THIN DOWEL (LESS THAN 5CM CIRCUMFERENCE) FOR SCHOOL PROGRAM 5 HOT GLUE GUNS AND HOT GLUE 5 STANLET KNIVES 2 SMALL CRAFT HACKSAWS 4 BALLS OF STRING 1 PK GARBAGE BAGS	1	66.72	
INV 2182/002	27/01/2023	BUNNINGS BUILDING SUPPLIES P/L	MISC. EQUIPMENT ITEMS - FLAGGING TAPE & MARKER STAKES	1	33.61	
INV 2182/003	30/01/2023	BUNNINGS BUILDING SUPPLIES P/L	9 VOLT BATTERIES 3 PACKS OF 3	1	30.81	
INV 2182/003	31/01/2023	BUNNINGS BUILDING SUPPLIES P/L	ROSE FEED	1	51.23	
INV 2182/003	01/02/2023	BUNNINGS BUILDING SUPPLIES P/L	SIKAFLEX	1	139.80	
INV 2182/002	02/02/2023	BUNNINGS BUILDING SUPPLIES P/L	18MM X 30M GARDEN HOSE	1	66.70	
EFT46410	09/02/2023	CLEANAWAY DANIELS SERVICES PTY LTD	APEX PARK PUBLIC TOILETS - 2 X SHARPS DISPOSAL SERVICE 9/1/23; 2 X SHARPS DISPOSAL SERVICE 16/1/23	1		377.61
INV 2150298	31/01/2023	CLEANAWAY DANIELS SERVICES PTY LTD	APEX PARK PUBLIC TOILETS - 2 X SHARPS DISPOSAL SERVICE 9/1/23; 2 X SHARPS DISPOSAL SERVICE 16/1/23	1	215.78	
INV 2150297	31/01/2023	CLEANAWAY DANIELS SERVICES PTY LTD	BERNARD PARK PUBLIC TOILETS X 3 SHARPS DISPOSAL SERVICE - 09/01/2023	1	161.83	
EFT46411	09/02/2023	CORSIGN WA PTY LTD	TD1 BRACKET C/W M10X21 CONETIP BOLT & M10 FLAT WASHER	1		264.00
INV 0007278631/01/2023		CORSIGN WA PTY LTD	TD1 BRACKET C/W M10X21 CONETIP BOLT & M10 FLAT WASHER	1	264.00	
EFT46412	09/02/2023	COUNTRYWIDE GROUP	CHLORINE LIQUID 15LT	1		443.63
INV ACC001901/02/0023		COUNTRYWIDE GROUP	CHLORINE LIQUID 15LT	1	227.00	

**Ordinary Council Meeting Minutes
15 March 2023**

Attachment 13.4.1.1

Date: 01/03/2023
Time: 8:24:14AM

Shire of Northam

USER: Louise Harris
PAGE: 20 10

Cheque /EFT No	Date	Name	Invoice Description	Bank Code	INV Amount	Amount
INV ACC001810/11/2022		COUNTRYWIDE GROUP	PUSH MOWER FRONT WHEELS	1	142.00	
INV ACC001901/02/2023		COUNTRYWIDE GROUP	PN1903 - HUSQVARNA TC328 RIDE ON MOWER REPAIRS	1	74.63	
EFT46413	09/02/2023	DAMIAN'S PLUMBING	INSTALL VALVE AND TEST POINT TO REUSED MAIN BEHIND POLO CLUB AS PER QUOTE 12/10/2022	1		7,260.00
INV 8240	01/02/2023	DAMIAN'S PLUMBING	INSTALL VALVE AND TEST POINT TO REUSED MAIN BEHIND POLO CLUB AS PER QUOTE 12/10/2022	1	7,260.00	
EFT46414	09/02/2023	DANIEL GARLETT	PLAYING OF THE DIDGERIDOO AND WELCOME TO COUNTRY AT CITIZENSHIP CEREMONY-AUSTRALIA DAY 26TH JAN 2023-BKB CENTRE	1		1,500.00
INV 49	26/01/2023	DANIEL GARLETT	PLAYING OF THE DIDGERIDOO AND WELCOME TO COUNTRY AT CITIZENSHIP CEREMONY-AUSTRALIA DAY 26TH JAN 2023-BKB CENTRE	1	1,500.00	
EFT46415	09/02/2023	DEBORAH L MOODY	WELCOME TO COUNTRY FOR BERNARD PARK STARGAZING - AUSTRALIA DAY 2023	1		300.00
INV 9	31/01/2023	DEBORAH L MOODY	WELCOME TO COUNTRY FOR BERNARD PARK STARGAZING - AUSTRALIA DAY 2023	1	300.00	
EFT46416	09/02/2023	DMC CLEANING	CONTRACT C.202021-05 - CLEANING SHIRE OF NORTHAM FACILITIES 1/1/23 - 31/1/23	1		10,825.38
INV SON211027/01/2023		DMC CLEANING	CONTRACT C.202021-05 - CLEANING OF SHIRE OF NORTHAM FACILITIES - CONSUMABLE PRODUCTS 11/01/2023	1	729.72	
INV SON201827/01/2023		DMC CLEANING	CONTRACT C.202021-05 - CLEANING SHIRE OF NORTHAM FACILITIES - CONSUMABLE PRODUCTS - 8/12/2022	1	1,289.84	
INV SON210927/01/2023		DMC CLEANING	CONTRACT C.202021-05 - CLEANING SHIRE OF NORTHAM FACILITIES - CONSUMABLE PRODUCT 12/12/2022	1	111.41	
INV SON211128/01/2023		DMC CLEANING	CONTRACT C.202021-05 - CLEANING SHIRE OF NORTHAM FACILITIES 1/1/23 - 31/1/23	1	8,694.41	
EFT46417	09/02/2023	DRACO AIR PTY LTD	WUNDOWIE DEPOT. SUPPLY 5 X INLINE WATER FILTERS.	1		316.25
INV 15092	14/12/2023	DRACO AIR PTY LTD	WUNDOWIE DEPOT. SUPPLY 5 X INLINE WATER FILTERS.	1	316.25	
EFT46418	09/02/2023	E & J LOGISTIC PTY LTD T/AS FLAT OUT FREIGHT	FREIGHT FROM NORTHAM RECREATION CENTRE TO ROYAL LIFE SAVING 27 JAN 2023	1		32.00

Ordinary Council Meeting Minutes
15 March 2023

Attachment 13.4.1.1

Date: 01/03/2023
Time: 8:24:14AM

Shire of Northam

USER: Louise Harris
PAGE: 21 10

Cheque /EFT No	Date	Name	Invoice Description	Bank Code	INV Amount	Amount
INV 0000525831	01/01/2023	E & J LOGISTIC PTY LTD T/AS FLAT OUT FREIGHT	FREIGHT FROM NORTHAM RECREATION CENTRE TO ROYAL LIFE SAVING 27 JAN 2023	1	32.00	
EFT46419	09/02/2023	E FIRE & SAFETY	MONTHLY ROUNTINE MAINTENANCE CHARGES FOR THE TESTING OF THE FIRE DETECTION SYSTEM AT KILLARA - JANUARY 2023	1		839.85
INV 579188	30/01/2023	E FIRE & SAFETY	MONTHLY ROUNTINE MAINTENANCE CHARGES FOR THE TESTING OF THE FIRE DETECTION SYSTEM AT NORTHAM RECREATION CENTRE - JANUARY 2023	1	162.80	
INV 579429	31/01/2023	E FIRE & SAFETY	MONTHLY ROUNTINE MAINTENANCE CHARGES FOR THE TESTING OF THE FIRE DETECTION SYSTEM AT KILLARA - JANUARY 2023	1	422.40	
INV 579185	31/01/2023	E FIRE & SAFETY	MONTHLY ROUNTINE MAINTENANCE CHARGES FOR THE TESTING OF THE FIRE DETECTION SYSTEM AT NORTHAM RECREATION CENTER - JANUARY 2023	1	254.65	
EFT46420	09/02/2023	ELDERS RURAL SERVICES AUSTRALIA LIMITED	GRIPPLES FORFENCING	1		53.40
INV AX 5577701	02/02/2023	ELDERS RURAL SERVICES AUSTRALIA LIMITED	GRIPPLES FORFENCING	1	53.40	
EFT46421	09/02/2023	FORMBYS LAWYERS	LODGEMENT OF CAVEAT - 15 WOOD DRIVE - NORTHAM COUNTRY CLUB	1		1,239.09
INV 002317	27/01/2023	FORMBYS LAWYERS	EXTENSION OF LEASE - IRISHTOWN HALL	1	517.00	
INV 002328	03/02/2023	FORMBYS LAWYERS	LODGEMENT OF CAVEAT - 15 WOOD DRIVE - NORTHAM COUNTRY CLUB	1	722.09	
EFT46422	09/02/2023	GEORGINA RIVERS	3HRS WORKED TO HELP WITH THE CITIZENSHIP CEREMONY ON 26 JANUARY 2023	1		150.00
INV 001	31/01/2023	GEORGINA RIVERS	3HRS WORKED TO HELP WITH THE CITIZENSHIP CEREMONY ON 26 JANUARY 2023	1	150.00	
EFT46423	09/02/2023	GOODYEAR & DUNLOP TYRES (AUST) PTY LTD	PN2104 REGO N.008 - SUPPLY AND FIT TYRE AS PER QUOTE U524364391	1		780.53
INV 6412933701	02/02/2023	GOODYEAR & DUNLOP TYRES (AUST) PTY LTD	PN2104 REGO N.008 - SUPPLY AND FIT TYRE AS PER QUOTE U524364391	1	780.53	
EFT46424	09/02/2023	GRAFTON ELECTRICS	CALL OUT TO FIX LEASURE POOL PUMP VSD	1		618.20
INV 9260	31/01/2023	GRAFTON ELECTRICS	CALL OUT TO FIX LEASURE POOL PUMP VSD	1	618.20	

**Ordinary Council Meeting Minutes
15 March 2023**

Attachment 13.4.1.1

Date: 01/03/2023
Time: 8:24:14AM

Shire of Northam

USER: Louise Harris
PAGE: 22 10

Cheque /EFT No	Date	Name	Invoice Description	Bank Code	INV Amount	Amount
EFT46425	09/02/2023	HARBOUR SOFTWARE PTY LTD	DOC ASSEMBLER INSTALLATION & TRAINING	1		7,700.00
INV 2139	03/02/2023	HARBOUR SOFTWARE PTY LTD	DOC ASSEMBLER INSTALLATION & TRAINING	1	7,700.00	
EFT46426	09/02/2023	JASON BRIAN WHITEAKER	REIMBURSEMENT OF TRAINING LEADING ECONOMIC GROWTH TRAINING HELD BY HARVARD KENNEDY SCHOOL NOTE: \$5900 USD TOTALS \$8448.84 AUD	1		8,448.84
INV KM 030203/02/2023		JASON BRIAN WHITEAKER	REIMBURSEMENT OF TRAINING LEADING ECONOMIC GROWTH TRAINING HELD BY HARVARD KENNEDY SCHOOL NOTE: \$5900 USD TOTALS \$8448.84 AUD	1	8,448.84	
EFT46427	09/02/2023	JASON SIGNMAKERS	3 X 150 HIGH STREET BLADES DOUBLE SIDED SON SPECS - CHITIBIN RD - THROSSELL ST - MAIRINGER WAY	1		141.90
INV 234731	31/01/2023	JASON SIGNMAKERS	3 X 150 HIGH STREET BLADES DOUBLE SIDED SON SPECS - CHITIBIN RD - THROSSELL ST - MAIRINGER WAY	1	141.90	
EFT46428	09/02/2023	KEITH BOASE	FUEL TANK FITTING FOR TURF PITCH ROLLER	1		12.99
INV SP 0302203/02/2023		KEITH BOASE	FUEL TANK FITTING FOR TURF PITCH ROLLER	1	12.99	
EFT46429	09/02/2023	KLEENHEAT GAS	GAS FOR NORTHAM SWIMMING POOL HEATERS - 23/01/2023	1		3,189.95
INV 2206074323/01/2023		KLEENHEAT GAS	GAS FOR NORTHAM SWIMMING POOL HEATERS - 23/01/2023	1	3,189.95	
EFT46430	09/02/2023	KLEENWEST	KRYSTAL KLEEN, TOILET KLEEN, RECTANGLE CONTAINERS, LIDS TO SUIT, TOILET PAPER & HAND TOWELS FOR KILLARA	1		250.86
INV 0007710601/02/2023		KLEENWEST	KRYSTAL KLEEN, TOILET KLEEN, RECTANGLE CONTAINERS, LIDS TO SUIT, TOILET PAPER & HAND TOWELS FOR KILLARA	1	250.86	

Ordinary Council Meeting Minutes
15 March 2023

Attachment 13.4.1.1

Date: 01/03/2023
Time: 8:24:14AM

Shire of Northam

USER: Louise Harris
PAGE: 23 10

Cheque /EFT No	Date	Name	Invoice Description	Bank Code	INV Amount	Amount
EFT46431	09/02/2023	LANDGATE	GROSS RENTAL VALUATIONS CHARGEABLE SCHEDULE G2022/13 FROM 29/10/2022 TO 25/11/2022	1		471.41
INV 380520	19/12/2022	LANDGATE	RURAL UV'S CHARGEABLE SCHEDULE R2022/13 FROM 29/10/2022 TO 25/11/2022	1	86.94	
INV 380601	20/12/2022	LANDGATE	GROSS RENTAL VALUATIONS CHARGEABLE SCHEDULE G2022/13 FROM 29/10/2022 TO 25/11/2022	1	384.47	
EFT46432	09/02/2023	LUME BRASSERIE - MADEELA PLT/AS	CATERING FOR ORDINARY COUNCIL MEETING - 25 JANUARY 2023 (LAMB SHANKS)	1		331.50
INV 69740	01/02/2023	LUME BRASSERIE - MADEELA PLT/AS	CATERING FOR ORDINARY COUNCIL MEETING - 25 JANUARY 2023 (LAMB SHANKS)	1	331.50	
EFT46433	09/02/2023	MATRIX PRODUCTIONS AUSTRALIA PTY LTD	AUSTRALIA DAY CITIZENSHIP CEREMONY-4.4MX3.5M BLACK COPORATE WOOL DRAPE	1		924.00
INV 39944	25/01/2023	MATRIX PRODUCTIONS AUSTRALIA PTY LTD	AUSTRALIA DAY CITIZENSHIP CEREMONY-4.4MX3.5M BLACK COPORATE WOOL DRAPE	1	924.00	
EFT46434	09/02/2023	MAYBERRY HAMMOND & CO	RENEWAL AND VARIATION OF LEASE - HANGAR SITE 34	1		649.00
INV 44808	09/01/2023	MAYBERRY HAMMOND & CO	RENEWAL AND VARIATION OF LEASE - HANGAR SITE 34	1	649.00	
EFT46435	09/02/2023	MENTAL MEDIA	GUIDE ID (PODCATCHER) SUBSCRIPTION SERVICE JAN - MARCH 2023	1		1,938.42
INV 1342	03/01/2023	MENTAL MEDIA	GUIDE ID (PODCATCHER) SUBSCRIPTION SERVICE JAN - MARCH 2023	1	1,938.42	
EFT46436	09/02/2023	NORTHAM DISTRICTS GLASS PTY LTD	PN1511 - N11164 - REPLACEMENT WINDSCREEN - NO LONGER COVERED UNDER INSURANCE	1		460.00
INV INV-407213/01/2023		NORTHAM DISTRICTS GLASS PTY LTD	PN1511 - N11164 - REPLACEMENT WINDSCREEN - NO LONGER COVERED UNDER INSURANCE	1	460.00	
EFT46437	09/02/2023	NORTHAM FEED & HIRE	SWAN FOOD & OTHER MISCELLANEOUS ITEMS - 30/1/2023	1		57.00
INV 0000467030/01/2023		NORTHAM FEED & HIRE	SWAN FOOD & OTHER MISCELLANEOUS ITEMS - 30/1/2023	1	57.00	
EFT46438	09/02/2023	NORTHAM TYREPOWER	PUNCTURE REPAIR FOR BROOM TYRE	1		50.00

**Ordinary Council Meeting Minutes
15 March 2023**

Attachment 13.4.1.1

Date: 01/03/2023
Time: 8:24:14AM

Shire of Northam

USER: Louise Harris
PAGE: 24 10

Cheque /EFT No	Date	Name	Invoice Description	Bank Code	INV Amount	Amount
INV 147142	01/02/2023	NORTHAM TYREPOWER	PUNCTURE REPAIR FOR BROOM TYRE	1	50.00	
EFT46439	09/02/2023	NORTHAM VETERINARY CENTRE	VET EXPENSES, DOG ATTACK "SASSY"	1		1,007.45
INV 100254	01/02/2023	NORTHAM VETERINARY CENTRE	TREAT INJURED CYGNET	1	107.52	
INV 100260	01/02/2023	NORTHAM VETERINARY CENTRE	VET EXPENSES, DOG ATTACK "SASSY"	1	899.93	
EFT46440	09/02/2023	NUTRIEN AG SOULTIONS LIMITED	RETIC FITTINGS	1		16.71
INV 9082085104/01/2023		NUTRIEN AG SOULTIONS LIMITED	RETIC FITTINGS	1	16.71	
EFT46441	09/02/2023	OFFICE WORKS SUPERSTORES PTY LTD	DESK PLANNER 2023 - JBCYDP2023	1		65.75
INV 6052210013/01/2023		OFFICE WORKS SUPERSTORES PTY LTD	DESK PLANNER 2023 - JBCYDP2023	1	65.75	
EFT46442	09/02/2023	PIZZA JOE'S WOODFIREDPIZZA	AUSTRALIA DAY MOVIE NIGHT 2023-EXTRA PIZZA FOR EXCESS ATTENDEESX 49 PIZZAS	1		686.00
INV 250123	25/01/2023	PIZZA JOE'S WOODFIREDPIZZA	AUSTRALIA DAY MOVIE NIGHT 2023-EXTRA PIZZA FOR EXCESS ATTENDEESX 49 PIZZAS	1	686.00	
EFT46443	09/02/2023	POOL AND PUMP SERVICE AND REPAIRS	REPLACE ACID DOSING PUMP TUBING - SUPPLY BUFFER - CLEAN & CALIBRATE PROBE	1		658.63
INVPPS0086425/01/2023		POOL AND PUMP SERVICE AND REPAIRS	REPLACE ACID DOSING PUMP TUBING - SUPPLY BUFFER - CLEAN & CALIBRATE PROBE	1	658.63	
EFT46444	09/02/2023	SOUTHERN CROSS AUSTEREO PTY LTD	24 X AROUND THE TOWNS INTERVIEWS - JANUARY 2023	1		198.00
INV 7143437731/01/2023		SOUTHERN CROSS AUSTEREO PTY LTD	24 X AROUND THE TOWNS INTERVIEWS - JANUARY 2023	1	198.00	

Ordinary Council Meeting Minutes
15 March 2023

Attachment 13.4.1.1

Date: 01/03/2023
Time: 8:24:14AM

Shire of Northam

USER: Louise Harris
PAGE: 25 10

Cheque /EFT No	Date	Name	Invoice Description	Bank Code	INV Amount	Amount
EFT46445	09/02/2023	SPECIALISED TREE SERVICE	JUBILEE OVAL - LARGE OLD SUGAR GUM NEXT TO SCOREBOARD SAFELY PRUNE TO REMOVE MAJORITY OF DEADWOOD AND BALANCE TREE TO REDUCE THE RISK OF FAILURES, ALL MATERIAL REMOVED FROM SITE. / EAST ST TO CHIDLOW ST SAFELY PRUNE ALL TREES WITH BRANCHES OVERHANGING PEEL TCE TO A HEIGHT OF APPROX 7MTRS, 2 TREES OVERHANGING THE INTERSECTION NEAR LIGHTS IN BMX AREA AND PRUNING BOTTLE BRUSHES ALONG FENCE OUTSIDE BMX AREA. ALL MATERIAL REMOVED FROM SITE./ TRAFFIC MANAGEMENT	1		11,812.30
INV 4026	06/02/2023	SPECIALISED TREE SERVICE	VARIOUS WORKS AS PER QUOTE #1083 - 35 PERINA WAY NORTHAM 10 NICHOLSON ST NORTHAM .50SLK GREGORY ST NORTHAM 1.43 SLK CLARKE ST NORTHAM	1	3,488.40	
INV 4025	06/02/2023	SPECIALISED TREE SERVICE	JUBILEE OVAL - LARGE OLD SUGAR GUM NEXT TO SCOREBOARD SAFELY PRUNE TO REMOVE MAJORITY OF DEADWOOD AND BALANCE TREE TO REDUCE THE RISK OF FAILURES, ALL MATERIAL REMOVED FROM SITE. / EAST ST TO CHIDLOW ST SAFELY PRUNE ALL TREES WITH BRANCHES OVERHANGING PEEL TCE TO A HEIGHT OF APPROX 7MTRS, 2 TREES OVERHANGING THE INTERSECTION NEAR LIGHTS IN BMX AREA AND PRUNING BOTTLE BRUSHES ALONG FENCE OUTSIDE BMX AREA. ALL MATERIAL REMOVED FROM SITE./ TRAFFIC MANAGEMENT	1	8,323.90	
EFT46446	09/02/2023	SPORTSMARKETING AUSTRALIA PTY LTD	NORTHAM ATHLETIC CHAMPIONSHIPS 2023	1		2,420.00
INV 0000328930/01/2023		SPORTSMARKETING AUSTRALIA PTY LTD	NORTHAM ATHLETIC CHAMPIONSHIPS 2023	1	2,420.00	
EFT46447	09/02/2023	THE WATERSHED	1" AIRVALVE RATED TO 1,000KPA	1		487.80

**Ordinary Council Meeting Minutes
15 March 2023**

Attachment 13.4.1.1

Date: 01/03/2023
Time: 8:24:14AM

Shire of Northam

USER: Louise Harris
PAGE: 26 10

Cheque /EFT No	Date	Name	Invoice Description	Bank Code	INV Amount	Amount
INV 1023154901/02/2023		THE WATERSHED	1" AIRVALVE RATED TO 1,000KPA	1	487.80	
EFT46448	09/02/2023	TOLL - IPEC PTY LTD T/AS	TOLL CHARGES - DECEMBER 2022 - HEALTH / WASTE / CESH	1		187.61
INV 0572-S3025/12/2022		TOLL - IPEC PTY LTD T/AS	TOLL CHARGES - DECEMBER 2022 - HEALTH / WASTE / CESH	1	105.60	
INV 0573-S30 15/01/2023		TOLL - IPEC PTY LTD T/AS	TOLL CHARGES - JANUARY 2023 - HEALTH	1	34.24	
INV 0574-S30 22/01/2023		TOLL - IPEC PTY LTD T/AS	TOLL CHARGES - JANUARY 2023 - HEALTH	1	47.77	
EFT46449	09/02/2023	TRANSWEST WA AUSTRALIAN STONE COMPANY PTY LTD	19MM MRD SPECS GRAVEL, 470 TONNE	1		27,519.63
INV INV-349431/01/2023		TRANSWEST WA AUSTRALIAN STONE COMPANY PTY LTD	CRACKER DUST 50 TONNE TO BE DELIVERED TO NORTHAM SHIRE DEPOT	1	1,021.39	
INV INV-344631/01/2023		TRANSWEST WA AUSTRALIAN STONE COMPANY PTY LTD	19MM MRD SPECS GRAVEL, 470 TONNE	1	10,421.84	
INV INV-344531/01/2023		TRANSWEST WA AUSTRALIAN STONE COMPANY PTY LTD	19MM ROAD BASED GRAVEL TO BE DELIVERED TO NORTHAM DEPOT FOR THE DEPOT CIVIL WORKS	1	10,267.08	
INV INV-345731/01/2023		TRANSWEST WA AUSTRALIAN STONE COMPANY PTY LTD	CRACKER DUST TO BE DELIVERED TO NORTHAM SHIRE DEPOT	1	978.56	
INV INV-348331/01/2023		TRANSWEST WA AUSTRALIAN STONE COMPANY PTY LTD	19MM MRD SPECS GRAVEL, 470 TONNE	1	4,830.76	
EFT46450	09/02/2023	WA CONTRACT RANGER SERVICES	MANAGMENT OF SHIRE OF NORTHAM DOG IMPOUND FACILITY 23/1/23 - 5/2/23	1		1,856.25
INV 0000451505/02/2023		WA CONTRACT RANGER SERVICES	MANAGMENT OF SHIRE OF NORTHAM DOG IMPOUND FACILITY 23/1/23 - 5/2/23	1	1,581.25	
INV 0000451405/02/2023		WA CONTRACT RANGER SERVICES	CAT MANAGEMENT - JANUARY 2023	1	275.00	
EFT46451	09/02/2023	WA FLAGS AND BANNERS - YATINDRA GODBOLE T/AS	3x SHIRE FLAGS FOR ADMIN BUILDING	1		877.80
INV 7345	24/01/2023	WA FLAGS AND BANNERS - YATINDRA GODBOLE T/AS	3x SHIRE FLAGS FOR ADMIN BUILDING	1	877.80	
EFT46452	09/02/2023	WESTERN IRRIGATION PTY LTD	REMOVAL & INSTALLATION, STRIP AND REPORT OF HENRY STREET PUMP STATION	1		3,366.00
INV P51293	31/01/2023	WESTERN IRRIGATION PTY LTD	REMOVAL & INSTALLATION, STRIP AND REPORT OF HENRY STREET PUMP STATION	1	3,366.00	

**Ordinary Council Meeting Minutes
15 March 2023**

Attachment 13.4.1.1

Date: 01/03/2023
Time: 8:24:14AM

Shire of Northam

USER: Louise Harris
PAGE: 27 10

Cheque /EFT No	Date	Name	Invoice Description	Bank Code	INV Amount	Amount
EFT46453	09/02/2023	WESTWIDE AUTO ELECTRICS AND AIR CONDITIONING	INKPEN 3.4 - ATTEND STATION, DIAGNOSE BATTERY AND CHARGING SYSTEM FAULT, REPLACE BATTERIES, AND UPGRADE SOLAR PANEL REGULATOR	1		3,349.04
INV INV-143813/01/2023		WESTWIDE AUTO ELECTRICS AND AIR CONDITIONING	CLACKLINE 2.4R – ATTEND STATION, DIAGNOSE AND REPAIR FAULT REPORTED WITH CAB A/C	1	401.00	
INV INV-144113/01/2023		WESTWIDE AUTO ELECTRICS AND AIR CONDITIONING	INKPEN 3.4 - ATTEND STATION, DIAGNOSE BATTERY AND CHARGING SYSTEM FAULT, REPLACE BATTERIES, AND UPGRADE SOLAR PANEL REGULATOR	1	510.54	
INV INV-144913/01/2023		WESTWIDE AUTO ELECTRICS AND AIR CONDITIONING	INKPEN 3.4 - ATTEND STATION, DIAGNOSE BATTERY AND CHARGING SYSTEM FAULT, REPLACE BATTERIES, AND UPGRADE SOLAR PANEL REGULATOR	1	1,482.50	
INV INV-145013/01/2023		WESTWIDE AUTO ELECTRICS AND AIR CONDITIONING	NEW BATTERY FOR GRASS VALLEY STANDPIPE	1	955.00	
EFT46454	09/02/2023	WHEATBELT NATURAL RESOURCE MANAGEMENT	MAINTENANCE OF NORTHAM CEMETERY AS PER C.201920 17 - FORTNIGHT ENDING 13/1/2023	1		3,853.09
INV 0030143816/01/2023		WHEATBELT NATURAL RESOURCE MANAGEMENT	MAINTENANCE OF NORTHAM CEMETERY AS PER C.201920-17 - FORTNIGHT ENDING 30/12/2022	1	986.21	
INV 0030144016/01/2023		WHEATBELT NATURAL RESOURCE MANAGEMENT	MAINTENANCE OF NORTHAM CEMETERY AS PER C.201920-17 - FORTNIGHT ENDING 13/1/2023	1	2,866.88	
EFT46455	09/02/2023	WHEATBELT PRECISION SERVICES - JEFFREY ROBERTS T/AS	1 BOX (20) OF THE HUNTER I20'S	1		880.00
INV INV-020601/02/2023		WHEATBELT PRECISION SERVICES - JEFFREY ROBERTS T/AS	1 BOX (20) OF THE HUNTER I20'S	1	880.00	
EFT46456	17/02/2023	AUSTRALIA POST	AUSTRALIA POST - JANUARY 2023 - ADMIN / LIBRARY	1		2,163.67
INV 1012170503/02/2023		AUSTRALIA POST	AUSTRALIA POST - JANUARY 2023 - ADMIN / LIBRARY	1	2,163.67	
EFT46457	17/02/2023	BUSINESS FUEL CARDS PTY LTD (FLEET CARD)	FUEL CHARGES FOR JANUARY2023	1		1,761.74
INV JANUAR31/01/2023		BUSINESS FUEL CARDS PTY LTD (FLEET CARD)	FUEL CHARGES FOR JANUARY2023	1	1,761.74	
EFT46458	17/02/2023	COLES SUPERMARKETS PTY LTD	COLES PURCHASES - JANUARY 2023 - KILLARA /HR / DEPOT / REC CENTRE / COMMUNITY SVS / LIBRARY / GOVERNANCE / DEVELOPMENT SVS / BKB / ADMIN	1		4,370.05

**Ordinary Council Meeting Minutes
15 March 2023**

Attachment 13.4.1.1

Date: 01/03/2023
Time: 8:24:14AM

Shire of Northam

USER: Louise Harris
PAGE: 28 10

Cheque /EFT No	Date	Name	Invoice Description	Bank Code	INV Amount	Amount
INV 187	31/01/2023	COLES SUPERMARKETS PTY LTD	COLES PURCHASES - JANUARY 2023 - KILLARA / HR / DEPOT / REC CENTRE / COMMUNITY SVS / LIBRARY / GOVERNANCE / DEVELOPMENT SVS / BKB / ADMIN	1	4,370.05	
EFT46459	17/02/2023	AFGRI EQUIPMENT AUSTRALIA PTY LTD	PN1622 FIELDQUIP MOWER GEARBOX	1		1,799.38
INV 2684735	09/02/2023	AFGRI EQUIPMENT AUSTRALIA PTY LTD	PN1622 FIELDQUIP MOWER GEARBOX	1	1,799.38	
EFT46460	17/02/2023	AGWEST MACHINERY - GREYMACH PTY LTD T/AS	K5698-34340 BLADE (H28TK309)	1		290.20
INV 340051	13/12/2022	AGWEST MACHINERY - GREYMACH PTY LTD T/AS	K5698-34340 BLADE (H28TK309)	1	290.20	
EFT46461	17/02/2023	ALLISON CONTRACTING AND BOILER MAKING - JACOB ALLISON T/AS	PLAYGROUND REPAIRS	1		242.00
INV INV-004210	02/2023	ALLISON CONTRACTING AND BOILER MAKING - JACOB ALLISON T/AS	PLAYGROUND REPAIRS	1	242.00	
EFT46462	17/02/2023	ANDY'S PLUMBINGSERVICE	SERVICE ICE MACHINE IN RECREATION CENTRE KITCHEN AT AQUATIC FACILITY	1		542.30
INV A19492	09/02/2023	ANDY'S PLUMBINGSERVICE	SERVICE ICE MACHINE IN RECREATION CENTRE KITCHEN AT AQUATIC FACILITY	1	302.50	
INV A19493	10/02/2023	ANDY'S PLUMBING SERVICE	INSPECT & REPAIR MAKE-UP WATER & REPLACE STANDARD TAP	1	239.80	
EFT46463	17/02/2023	APPLIED INDUSTRIAL TECHNOLOGIES T/A NORTHAM BEARINGS	TWO PRESSUREGUAGES	1		130.15
INV 7091094	08/02/2023	APPLIED INDUSTRIAL TECHNOLOGIES T/A NORTHAM BEARINGS	TWO PRESSUREGUAGES	1	130.15	
EFT46464	17/02/2023	AUSTRALIAN SERVICES UNION	PAYROLL DEDUCTIONS	1		129.50
INV DEDUCT14	02/2023	AUSTRALIAN SERVICES UNION	PAYROLL DEDUCTIONS		129.50	
EFT46465	17/02/2023	AUTOPRO NORTHAM	2x RELAYS	1		32.18
INV 1046861	10/02/2023	AUTOPRO NORTHAM	2x RELAYS	1	32.18	
EFT46466	17/02/2023	BAKERS HILL RURAL SUPPLIES & HARDWARE	10 MT TARP ROPE FOR WUNDOWIE DEPOT	1		9.00

Ordinary Council Meeting Minutes
15 March 2023

Attachment 13.4.1.1

Date: 01/03/2023
Time: 8:24:14AM

Shire of Northam

USER: Louise Harris
PAGE: 29 10

Cheque /EFT No	Date	Name	Invoice Description	Bank Code	INV Amount	Amount
INV 181025	09/02/2023	BAKERS HILL RURAL SUPPLIES & HARDWARE	10 MT TARP ROPE FOR WUNDOWIE DEPOT	1	9.00	
EFT46467	17/02/2023	BEAM ME UP MEDIA PTY LTD	SHIRE OF NORTHAM AUSTRALIA DAY EVENT, JANUARY 26TH, 2023. 2.5 HRS INCLUDING 2XASTRONOMY GUIDES, 4 LARGE TELESCOPES, ABORIGINAL ASTRONOMY GUIDE STORYTELLING, ABORIGINAL CONSTELLATIONS NIGHT SKY TOUR, ABORIGINAL DANCE PERFORMANCE, GREEN LASER POINTER TOUR, STAR GAZING, 50 X BALARDONG PLANISPHERES GIVE AWAY, TRAVEL AND ACCOMODATION COSTS AND EVENT DESIGN.	1		5,318.50
INV INV-004728/01/2023		BEAM ME UP MEDIA PTY LTD	SHIRE OF NORTHAM AUSTRALIA DAY EVENT, JANUARY 26TH, 2023. 2.5 HRS INCLUDING 2XASTRONOMY GUIDES, 4 LARGE TELESCOPES, ABORIGINAL ASTRONOMY GUIDE STORYTELLING, ABORIGINAL CONSTELLATIONS NIGHT SKY TOUR, ABORIGINAL DANCE PERFORMANCE, GREEN LASER POINTER TOUR, STAR GAZING, 50 X BALARDONG PLANISPHERES GIVE AWAY, TRAVEL AND ACCOMODATION COSTS AND EVENT DESIGN.	1	5,318.50	
EFT46468	17/02/2023	BELINGARNI FABRICATION HOME AND PROPERTY SERVICES	FUEL REDUCTION A306 32 HOVEA CRESCENTNORTHAM	1		492.00
INV 984	29/01/2023	BELINGARNI FABRICATION HOME AND PROPERTY SERVICES	FUEL REDUCTION A10432 209 CHIDLOW STREET NORTHAM	1	492.00	
EFT46469	17/02/2023	BUNNINGS BUILDING SUPPLIES P/L	PLAYGROUND MAINTENANCE - HINGES, LOCKS, RETIC	1		804.35
INV 2182/003	25/01/2023	BUNNINGS BUILDING SUPPLIES P/L	GIFT FOR CITIZENSHIP CEREMONY - 26 JANUARY 2023 - NATIVE PLANTS x8	1	93.36	
INV 2182/003	30/01/2023	BUNNINGS BUILDING SUPPLIES P/L	CUTTING OF KEYS	1	12.88	
INV 2182/003	01/02/2023	BUNNINGS BUILDING SUPPLIES P/L	MORGAN STAINLESS STEEL TOILET BRUSH & HOSE CONNECTOR	1	73.86	

**Ordinary Council Meeting Minutes
15 March 2023**

Attachment 13.4.1.1

Date: 01/03/2023
Time: 8:24:14AM

Shire of Northam

USER: Louise Harris
PAGE: 30 10

Cheque /EFT No	Date	Name	Invoice Description	Bank Code	INV Amount	Amount
INV 2182/003	02/02/2023	BUNNINGS BUILDING SUPPLIES P/L	KEY CUTTING	1	12.88	
INV 2182/003	06/02/2023	BUNNINGS BUILDING SUPPLIES P/L	TAPE MEASURE	1	19.00	
INV 2182/003	08/02/2023	BUNNINGS BUILDING SUPPLIES P/L	4LITRE BRITISH PAINT LOW SHEEN WHITE EXTERIOR PAINT BRUSHES & PLAY SAND	1	241.02	
INV 2182/003	08/02/2023	BUNNINGS BUILDING SUPPLIES P/L	PLAYGROUND MAINTENANCE - HINGES, LOCKS, RETIC	1	351.35	
EFT46470	17/02/2023	CENTRAL MOBILE MECHANICAL REPAIRS	PN1706 REGO N.001 - SERVICE 7000HRS	1		3,939.60
INV 0000429907	02/2023	CENTRAL MOBILE MECHANICAL REPAIRS	PN1706 REGO N.001 - SERVICE 7000HRS	1	1,769.79	
INV 0000429807	02/2023	CENTRAL MOBILE MECHANICAL REPAIRS	PN1502 REGO N4174 - SERVICE 8000HRS	1	1,460.31	
INV 0000429707	02/2023	CENTRAL MOBILE MECHANICAL REPAIRS	PICK UP STEEL DRUM ROLLER FROM DEPOT AND DROP OFF AT GRASS VALLEY NTH RD	1	709.50	
EFT46471	17/02/2023	CHILD SUPPORT AGENCY	PAYROLL DEDUCTIONS	1		485.44
INV DEDUCT14	02/2023	CHILD SUPPORT AGENCY	PAYROLL DEDUCTIONS		485.44	
EFT46472	17/02/2023	CHRISTOPHER JOHN MARRIS	CBFCO HONORARIUM PAYMENT FOR JANUARY 2023	1		833.33
INV AE 0902209	02/2023	CHRISTOPHER JOHN MARRIS	CBFCO HONORARIUM PAYMENT FOR JANUARY 2023	1	833.33	
EFT46473	17/02/2023	CIVIL TECHNOLOGY	RELEASE OF DEFECT LIABILITY BOND PAID AT STAGE 1 AND CARRIED OVER TO STAGE 2 OYSTON ROAD, BAKERS HILL (S153240) AS PER EMAIL FROM CHAN VYAS (REF: N19885) DATED 02/02/2023.	1		19,223.24
INV T1155	16/02/2023	CIVIL TECHNOLOGY	RELEASE OF DEFECT LIABILITY BOND PAID AT STAGE 1 AND CARRIED OVER TO STAGE 2 OYSTON ROAD, BAKERS HILL (S153240) AS PER EMAIL FROM CHAN VYAS (REF: N19885) DATED 02/02/2023.	1	19,223.24	
EFT46474	17/02/2023	CJD EQUIPMENT PTY LTD	BOLTS, NUTS AND WASHERS (12 OF EACH)	1		232.72
INV 0025739610	02/2023	CJD EQUIPMENT PTY LTD		1	232.72	
EFT46475	17/02/2023	COUNTRYWIDE GROUP	PULL CORD AND AIR FILTERS FOR CEMENT MIXER	1		321.00
INV ACC001909	02/2023	COUNTRYWIDE GROUP	PN1611 AIR FILTERS	1	61.00	
INV ACC001910	02/2023	COUNTRYWIDE GROUP	PULL CORD AND AIR FILTERS FOR CEMENT MIXER	1	260.00	

**Ordinary Council Meeting Minutes
15 March 2023**

Attachment 13.4.1.1

Date: 01/03/2023
Time: 8:24:14AM

Shire of Northam

USER: Louise Harris
PAGE: 31 10

Cheque /EFT No	Date	Name	Invoice Description	Bank Code	INV Amount	Amount
EFT46476	17/02/2023	CTI LOGISTICS REGIONAL FREIGHT - CTI FREIGHT MANAGEMENT PL T/AS	CTI FREIGHT MOVEMENTS - JANUARY 2023 - DEPOT	1		394.49
INV CISF537831/01/2023		CTI LOGISTICS REGIONAL FREIGHT - CTI FREIGHT MANAGEMENT PL T/AS	CTI FREIGHT MOVEMENTS - JANUARY 2023 - DEPOT	1	394.49	
EFT46477	17/02/2023	DCM CARPENTRY & MAINTENANCE	REPAIR< PATCH<PAINT - HOLE IN RECEPTION WALL	1		671.00
INV 1501	16/01/2023	DCM CARPENTRY & MAINTENANCE	PATCH AND REPAIR PAINT IN KIOSK	1	275.00	
INV 1500	16/01/2023	DCM CARPENTRY & MAINTENANCE	REPAIR< PATCH<PAINT - HOLE IN RECEPTION WALL	1	396.00	
EFT46478	17/02/2023	DOMINOS NORTHAM - GC PIZZA TRUST - AUSSIE NG PL	20 PIZZAS PICK UP WEDNESDAY 08/02/23	1		286.55
INV 0202202302/02/2023		DOMINOS NORTHAM - GC PIZZA TRUST - AUSSIE NG PL	CATERING RECREATION SERVICES TRAINING SESSION - 10 X PIZZA	1	99.90	
INV 0802202308/02/2023		DOMINOS NORTHAM - GC PIZZA TRUST - AUSSIE NG PL	20 PIZZAS PICK UP WEDNESDAY 08/02/23	1	186.65	
EFT46479	17/02/2023	DUN DIRECT PTY LTD	FUEL CHARGES FOR JANUARY 2023	1		28,350.31
INV JANUAR31/01/2023		DUN DIRECT PTY LTD	FUEL CHARGES FOR JANUARY 2023	1	28,350.31	
EFT46480	17/02/2023	EASIFLEET	PAYROLL DEDUCTIONS	1		1,853.35
INV DEDUCT14/02/2023		EASIFLEET	PAYROLL DEDUCTIONS		1,054.26	
INV DEDUCT14/02/2023		EASIFLEET	PAYROLL DEDUCTIONS		799.09	
EFT46481	17/02/2023	ELIZABETH ANNE PRICE	RATES CREDIT REFUND FOR ASSESSMENT A2596	1		123.25
INV A2596	15/02/2023	ELIZABETH ANNE PRICE	RATES CREDIT REFUND FOR ASSESSMENT A2596		123.25	
EFT46482	17/02/2023	FRAMESWEST	CHAIR TROLLEY	1		759.00
INV 0000111001/02/2023		FRAMESWEST	CHAIR TROLLEY	1	759.00	
EFT46483	17/02/2023	FULTON HOGAN INDUSTRIES PTY LTD	2 X 2000LT IBC'S OF EMULSION - SUMMER GRADE	1		2,860.00
INV 1732093609/02/2023		FULTON HOGAN INDUSTRIES PTY LTD	2 X 2000LT IBC'S OF EMULSION - SUMMER GRADE	1	2,860.00	
EFT46484	17/02/2023	G.S. BEVERIDGE & L.P. NOTTLE	BILYA KOORT BOODJA. PRESSURE WASH EXTERNAL WALLS AND CEILINGS PRIOR TO AUS DAY.	1		1,970.00

**Ordinary Council Meeting Minutes
15 March 2023**

Attachment 13.4.1.1

Date: 01/03/2023
Time: 8:24:14AM

Shire of Northam

USER: Louise Harris
PAGE: 32 10

Cheque /EFT No	Date	Name	Invoice Description	Bank Code	INV Amount	Amount
INV 381	23/01/2023	G.S. BEVERIDGE & L.P. NOTTLE	BILYA KOORT BOODJA. PRESSURE WASH EXTERNAL WALLS AND CEILINGS PRIOR TO AUS DAY.	1	1,970.00	
EFT46485	17/02/2023	GHD PTY LTD	C.202122-10 SHIRE OF NORTHAM REUSE WATER SCHEME UPGRADE - PROGRESS CLAIM 5	1		15,354.90
INV 112-0151	01/02/2023	GHD PTY LTD	C.202122-10 SHIRE OF NORTHAM REUSE WATER SCHEME UPGRADE - PROGRESS CLAIM 5	1	15,354.90	
EFT46486	17/02/2023	GRAFTON ELECTRICS	INSPECT MAKE UP WATER SENSOR/ AUTOFILL	1		362.56
INV 9271	06/02/2023	GRAFTON ELECTRICS	INSPECT MAKE UP WATER SENSOR/ AUTOFILL	1	362.56	
EFT46487	17/02/2023	GUY MITCHELL CLEVELAND	RATES INCENTIVE PRIZE - \$500 DONATED BY SPECIALISED TREE SERVICES	1		500.00
INV CY 1402214	02/2023	GUY MITCHELL CLEVELAND	RATES INCENTIVE PRIZE - \$500 DONATED BY SPECIALISED TREE SERVICES	1	500.00	
EFT46488	17/02/2023	INTERFIRE AGENCIES PTY LTD T/A LOVETT FAMILY TRUST	SEAGUARD CLASS A FOAM CONCENTRATE BFFF 0.1% TO 1.0% USDA APPROVED – 20LT X 32	1		3,681.57
INV INV-132807	02/2023	INTERFIRE AGENCIES PTY LTD T/A LOVETT FAMILY TRUST	SEAGUARD CLASS A FOAM CONCENTRATE BFFF 0.1% TO 1.0% USDA APPROVED – 20LT X 32	1	3,681.57	
EFT46489	17/02/2023	INTERSECTIONAL LINEMARKERS PTY LTD	C.202223-04 - SPENCERS BROOK ROAD AUDIBLE EDGE LINE MARKING - CLAIM ONE	1		250,574.85
INV 10857	30/12/2022	INTERSECTIONAL LINEMARKERS PTY LTD	C.202223-04 - SPENCERS BROOK ROAD AUDIBLE EDGE LINE MARKING - CLAIM ONE	1	250,574.85	
EFT46490	17/02/2023	IXOM OPERATIONS PTY LTD	CLORINE MONTHLY SERVICE FEE FOR WWTP / NORTHAM AQUATIC FACILITY - JANUARY 2023	1		522.75
INV 6627936	31/01/2023	IXOM OPERATIONS PTY LTD	CLORINE MONTHLY SERVICE FEE FOR WWTP / NORTHAM AQUATIC FACILITY - JANUARY 2023	1	522.75	
EFT46491	17/02/2023	JACK RONALD PARMENTER	REIMBURSE WORKING WITH CHILDREN CHECK	1		87.00
INV 4296515	07/02/2023	JACK RONALD PARMENTER	REIMBURSE WORKING WITH CHILDREN CHECK	1	87.00	
EFT46492	17/02/2023	JASON SIGNMAKERS	D4-2-1A[U] BIDIRECTIONAL, 1800 x 300, 1.6MM ALI - CLASS 400 (CL1)- BLK on WHT - W/ STRUTS	1		461.91
INV 27286	10/02/2023	JASON SIGNMAKERS	G5-1A STREET NAME 150MM HIGH ALI EXTRUSION- CLASS 400 (CL1) VINYL- PRINT ON WHT DOUBLE-SIDED - NORTHAM EMERGENCY SERVICES COMPLEX	1	98.19	

**Ordinary Council Meeting Minutes
15 March 2023**

Attachment 13.4.1.1

Date: 01/03/2023
Time: 8:24:14AM

Shire of Northam

USER: Louise Harris
PAGE: 33 10

Cheque /EFT No	Date	Name	Invoice Description	Bank Code	INV Amount	Amount
INV 27306	13/02/2023	JASON SIGNMAKERS	D4-2-1A[U] BIDIRECTIONAL, 1800 x 300, 1.6MM ALI - CLASS 400 (CL1)- BLK on WHT - W/ STRUTS	1	363.72	
EFT46493	17/02/2023	JENNIFER ANNE O'BRIEN	REIMBURSE FOR KILLARA SHOPPING	1		18.54
INV NH 0702207/02/2023		JENNIFER ANNE O'BRIEN	REIMBURSE FOR KILLARA SHOPPING	1	18.54	
EFT46494	17/02/2023	JH COMPUTER SERVICES PTY LTD	AP840 ACCESS POINT - ALL AS PER QUOTE#0000023771-D01	1		1,309.00
INV 0000207529/01/2023		JH COMPUTER SERVICES PTY LTD	AP840 ACCESS POINT - ALL AS PER QUOTE#0000023771-D01	1	1,309.00	
EFT46495	17/02/2023	KEITH BOASE	OTTO ADHESIVE ROLL WHITEBOARD 2M X 2	1		11.96
INV CH 1402214/02/2023		KEITH BOASE	OTTO ADHESIVE ROLL WHITEBOARD 2M X 2	1	11.96	
EFT46496	17/02/2023	KEYCRAFT AUSTRALIA PTY LTD	LIVING NATURE SWAN LARGE SKU AN380	1		214.50
INV IN20348 20/12/2022		KEYCRAFT AUSTRALIA PTY LTD	LIVING NATURE SWAN LARGE SKU AN380	1	214.50	
EFT46497	17/02/2023	KUNAL SARMA	REIMBURSEMENT OF POLICE CLEARANCE KUNAL SARMA (BUSINESS SOLUTIONS COORDINATOR)	1		58.70
INV 7FD328E09/12/2022		KUNAL SARMA	REIMBURSEMENT OF POLICE CLEARANCE KUNAL SARMA (BUSINESS SOLUTIONS COORDINATOR)	1	58.70	
EFT46498	17/02/2023	LUCY'S TEAROOMS	INCIDENT LUNCHES	1		115.50
INV 2851	24/10/2022	LUCY'S TEAROOMS	INCIDENT LUNCHES	1	115.50	
EFT46499	17/02/2023	MAIN ROADS WA - HEADOFFICE	REFUND - BLACKSPOT FUNDING - OVER CLAIM FOR MITCHELL AVE, NORTHAM	1		5,507.70
INV SP 3001230/01/2023		MAIN ROADS WA - HEADOFFICE	REFUND - BLACKSPOT FUNDING - OVER CLAIM FOR MITCHELL AVE, NORTHAM	1	5,507.70	
EFT46500	17/02/2023	MARKETFORCE	AD IN WEST AUSTRALIAN 07/01/2023 - RFT 01 OF 2023 - CEMETERY GRAVE DIGGING	1		1,156.35
INV 40833	03/01/2023	MARKETFORCE	EARLY SETTLEMENT DISCOUNT	1	-36.49	
INV 40833	03/01/2023	MARKETFORCE	EARLY SETTLEMENT DISCOUNT	1	-23.38	
INV 46611	25/01/2023	MARKETFORCE	AD IN WEST AUSTRALIAN 07/01/2023 - RFT 01 OF 2023 - CEMETERY GRAVE DIGGING	1	748.76	

**Ordinary Council Meeting Minutes
15 March 2023**

Attachment 13.4.1.1

Date: 01/03/2023
Time: 8:24:14AM

Shire of Northam

USER: Louise Harris
PAGE: 34 10

Cheque /EFT No	Date	Name	Invoice Description	Bank Code	INV Amount	Amount
INV 46612	25/01/2023	MARKETFORCE	AD FOR DISPOSAL HANGAR 34 - WEST 12th 2023	1	531.75	
INV 40950	01/02/2023	MARKETFORCE	CREDIT - EARLY SETTLEMENT DISCOUNT INVOICE 46316	1	-39.77	
INV 40950	01/02/2023	MARKETFORCE	CREDIT - EARLY SETTLEMENT DISCOUNT FOR INVOICE 46317	1	-24.52	
EFT46501	17/02/2023	MCDOWALL AFFLECK PTY LTD	MINSON AVE CAR PARK DETAILED DESIGN	1		10,279.50
INV 613072	30/01/2023	MCDOWALL AFFLECK PTY LTD	MINSON AVENUE CARPARK CONCEPT DESIGN	1	748.00	
INV 613072	30/01/2023	MCDOWALL AFFLECK PTY LTD	MINSON AVE CAR PARK DETAILED DESIGN	1	6,039.00	
INV 613076	31/01/2023	MCDOWALL AFFLECK PTY LTD	YILGARN AVE CULVERT DESIGN - DRAINAGE DESIGN REPORT / CIVIL DESIGN DRAWING	1	3,492.50	
EFT46502	17/02/2023	MINT CIVIL PTY LTD T/AS IMMACU SWEEP	C.201819-12 STREET SWEEPING & GULLY EDUCATION SERVICES (CLEANING TOWN ROADS) / FOOTPATH & VERGE SWEEPING OF CBD - 23/1/2023 - 29/1/2023	1		7,801.20
INV N3099	06/02/2023	MINT CIVIL PTY LTD T/AS IMMACU SWEEP	C.201819-12 STREET SWEEPING & GULLY EDUCATION SERVICES (CLEANING TOWN ROADS) / FOOTPATH & VERGE SWEEPING OF CBD - 23/1/2023 - 29/1/2023	1	3,900.60	
INV N3100	06/02/2023	MINT CIVIL PTY LTD T/AS IMMACU SWEEP	C.201819-12 STREET SWEEPING & GULLY EDUCATION SERVICES (CLEANING TOWN ROADS) / FOOTPATH & VERGE SWEEPING OF CBD - 30/1/2023 - 5/2/2023	1	3,900.60	
EFT46503	17/02/2023	NORTHAM COUNTRY CLUB INC	SENIOR SPORT FUNDING - PETER HADDRILL	1		100.00
INV 4500	23/12/2022	NORTHAM COUNTRY CLUB INC	SENIOR SPORT FUNDING - PETER HADDRILL	1	100.00	
EFT46504	17/02/2023	NORTHAM TOWINGSERVICE	PN1612 - TRUCK RESCUE OPERATON AT JILYADING DRIVE 09/02/2023	1		275.00
INV 212182	11/02/2023	NORTHAM TOWINGSERVICE	PN1612 - TRUCK RESCUE OPERATON AT JILYADING DRIVE 09/02/2023	1	275.00	
EFT46505	17/02/2023	NORTHAM TYREPOWER	TWO GRADER TYRES AS PER QUOTE Q103004, INCLUDING FITTING AND DISPOSAL	1		3,525.00
INV 146988	20/01/2023	NORTHAM TYREPOWER	TWO GRADER TYRES AS PER QUOTE Q103004, INCLUDING FITTING AND DISPOSAL	1	2,070.00	
INV 147205	07/02/2023	NORTHAM TYREPOWER	MICHELIN 11R22.5 XDY 3 TL 148/145K TRUCK TYRES	1	1,455.00	
EFT46506	17/02/2023	OXTER SERVICES	CARTON 240LTR RUBBISH BAGS	1		122.84

**Ordinary Council Meeting Minutes
15 March 2023**

Attachment 13.4.1.1

Date: 01/03/2023
Time: 8:24:14AM

Shire of Northam

USER: Louise Harris
PAGE: 35 10

Cheque /EFT No	Date	Name	Invoice Description	Bank Code	INV Amount	Amount
INV 26817	18/01/2023	OXTER SERVICES	CREDIT NOTE 3 X 12OZ COFFEE CUPS AND LIDS	1	-19.47	
INV 26898	09/02/2023	OXTER SERVICES	CARTON 240LTR RUBBISH BAGS	1	142.31	
EFT46507	17/02/2023	POOL AND PUMP SERVICE AND REPAIRS	SERVICE TO NORTHAM WATER PARK PLUS REPORT	1		484.00
INV PPS0084513/12/2022		POOL AND PUMP SERVICE AND REPAIRS	SERVICE TO NORTHAM WATER PARK PLUS REPORT	1	484.00	
EFT46508	17/02/2023	PORTER CONSULTINGENGINEERS	FLYING 50's RACETRACK RELOCATION AS PER C.202122-09 - WORKS COMPLETED TO 27 JANUARY 2023	1		7,645.00
INV 0023010	30/01/2023	PORTER CONSULTINGENGINEERS	FLYING 50's RACETRACK RELOCATION AS PER C.202122-09 - WORKS COMPLETED TO 27 JANUARY 2023	1	7,645.00	
EFT46509	17/02/2023	PROMPTSETTLEMENTS	DISCHARGE OF 2 MORGAGES AND 1 CAVEAT - 15 WOOD DRIVE	1		420.08
INV 2747N	03/02/2023	PROMPTSETTLEMENTS	DISCHARGE OF 2 MORGAGES AND 1 CAVEAT - 15 WOOD DRIVE	1	420.08	
EFT46510	17/02/2023	PUMA - WEX AUSTRALIA PTY LTD	FUEL CHARGES FOR JANUARY 2023	1		1,407.86
INV JANUAR31/01/2023		PUMA - WEX AUSTRALIA PTY LTD	FUEL CHARGES FOR JANUARY 2023	1	1,407.86	
EFT46511	17/02/2023	REGIONAL PHYSIOTHERAPY & SPORTS INJURY CLINIC & IN BALANCEFITNESS	REGIONAL PHYSIOTHERAPY & SPORTS INJURY CLINIC & IN BALANCE FITNESS	1		99.00
INV 0081264	13/02/2023	REGIONAL PHYSIOTHERAPY & SPORTS INJURY CLINIC & IN BALANCE FITNESS	REGIONAL PHYSIOTHERAPY & SPORTS INJURY CLINIC & IN BALANCE FITNESS	1	99.00	
EFT46512	17/02/2023	RICHARD ALWYNBLYTH	LOT 24004 MCNAMARA ROAD WUNDOWIE CROSS OVER REBATE	1		2,000.00
INV SP 0702207/02/2023		RICHARD ALWYNBLYTH	LOT 24004 MCNAMARA ROAD WUNDOWIE CROSS OVER REBATE	1	2,000.00	
EFT46513	17/02/2023	RONLIEEH PTY LTD T/AS ALL PARTS WA	DOUBLE BATTERY PACK	1		324.82
INV SI-00007709/02/2023		RONLIEEH PTY LTD T/AS ALL PARTS WA	DOUBLE BATTERY PACK	1	274.00	
INV SI-00007810/02/2023		RONLIEEH PTY LTD T/AS ALL PARTS WA	WPC-5405-580-4 ORANGAGRIP NITRILE GLOVES CTN	1	50.82	
EFT46514	17/02/2023	SHRED-X PTY LTD	EMPTYING OF SHREDDER BIN FOR DEPOT, 116 PEEL TCE NORTHAM	1		151.20
INV 0195547731/01/2023		SHRED-X PTY LTD	EMPTYING OF SHREDDER BIN FOR DEPOT, 116 PEEL TCE NORTHAM	1	75.60	

**Ordinary Council Meeting Minutes
15 March 2023**

Attachment 13.4.1.1

Date: 01/03/2023
Time: 8:24:14AM

Shire of Northam

USER: Louise Harris
PAGE: 36 10

Cheque /EFT No	Date	Name	Invoice Description	Bank Code	INV Amount	Amount
INV 0195547731/01/2023		SHRED-X PTY LTD	EMPTYING OF ADMIN SHREDDER	1	75.60	
EFT46515	17/02/2023	SYNERGY	361669310 RECREATION PRECINCT - 11/01/2023 to 07/02/2023	1		21,303.19
INV 3575491201/02/2023		SYNERGY	357549120 NORTHAM DEPOT - PEEL ST - 26/11/2022 to 31/01/2023	1	1,648.07	
INV 1539025101/02/2023		SYNERGY	153902510 OLD NORTHAM DEPOT - 26/11/2022 to 31/01/2023	1	135.74	
INV 3355969202/02/2023		SYNERGY	335596920 NORTHAM VISITORS CENTRE - 29/11/2022 to 01/02/2023		504.98	
INV 3577000202/02/2023		SYNERGY	357700020 KILLARA DAYCARE CENTRE - 29/11/2022 to 01/02/2023	1	971.61	
INV 3575480803/02/2023		SYNERGY	357548080 DOG POUND COLEBATCH RD - 22/11/2022 to 25/01/2023		404.67	
INV 3749669503/02/2023		SYNERGY	374966950 BEAVIS PLACE OPEN SPACE - 30/11/2022 to 02/02/2023		189.95	
INV 3575487006/02/2023		SYNERGY	357548700 TOWN HALL & LESSER HALL - 01/12/2022 to 03/02/2023		682.62	
INV 3575483206/02/2023		SYNERGY	357548320 BERNARD PARK TOILETS - 01/12/2022 to 03/02/2023		205.00	
INV 3577047906/02/2023		SYNERGY	357704790 STAGE LIGHTS - SOUNDSHELL - 30/11/2022 to 03/02/2023		780.55	
INV 9356001406/02/2023		SYNERGY	935600140 NORTHAM VISITORS CENTRE - 01/12/2022 to 03/02/2023		307.99	
INV 1578225606/02/2023		SYNERGY	157822560 IRISHTOWN BFB - 18/11/2022 to 19/01/2023		185.04	
INV 3577050606/02/2023		SYNERGY	357705060 GREY ST AVON DESCENT POOL AERATORS - 01/12/2022 to 03/02/2023		1,098.09	
INV 3577034207/02/2023		SYNERGY	357703420 PURSLOWE PARK - 01/12/2022 to 01/02/2023		121.80	
INV 3575481307/02/2023		SYNERGY	357548130 MEMORIAL HALL - 30/11/2022 to 02/02/2023		781.69	
INV 1127695007/02/2023		SYNERGY	112769500 MEN'S SHED / OLD FIRE STATION - 30/11/2022 to 02/02/2023		317.97	
INV 3616693108/02/2023		SYNERGY	361669310 RECREATION PRECINCT - 11/01/2023 to 07/02/2023		11,187.13	
INV 3577039908/02/2023		SYNERGY	357703990 BERT HAWKE PAVILION & LIGHTS - 11/01/2023 to 07/02/2023		248.35	
INV 2931107308/02/2023		SYNERGY	293110730 BILYA KOORT BOODJA - 11/01/2023 to 07/02/2023		995.62	

Ordinary Council Meeting Minutes
15 March 2023

Attachment 13.4.1.1

Date: 01/03/2023
Time: 8:24:14AM

Shire of Northam

USER: Louise Harris
PAGE: 37 10

Cheque /EFT No	Date	Name	Invoice Description	Bank Code	INV Amount	Amount
INV 2361098008/02/2023		SYNERGY	236109800 RAP PARK - 03/12/2022 to 06/02/2023		126.97	
INV 3577051109/02/2023		SYNERGY	357705110 RAILWAY MUSEUM - 06/12/2022 to 08/02/2023		409.35	
EFT46516	17/02/2023	TALIS CONSULTANTS PTY LTD	C.202021-24 - PROVISION OF CONSULTANCY SERVICES FOR THE PERIOD ENDING 30 NOVEMBER 2022. STORM EVENT 2-4 MARCH 2021 - AGRN962	1		756.26
INV 27582	31/12/2022	TALIS CONSULTANTS PTY LTD	C.202021-24 - PROVISION OF CONSULTANCY SERVICES FOR THE PERIOD ENDING 30 NOVEMBER 2022. STORM EVENT 2-4 MARCH 2021 - AGRN962	1	756.26	
EFT46517	17/02/2023	THE WORKWEAR GROUP	ELIJAH MOORHEAD - UNIFORMS	1		289.51
INV 1433922126/09/2022		THE WORKWEAR GROUP	ELIJAH MOORHEAD - UNIFORMS	1	289.51	
EFT46518	17/02/2023	TOLL - IPEC PTY LTD T/AS	TOLL FREIGHT - JANUARY 2023 - HEALTH / DEPOT / CESM	1		353.56
INV 0575-S3029/01/2023		TOLL - IPEC PTY LTD T/AS	TOLL FREIGHT - JANUARY 2023 - HEALTH / DEPOT / CESM	1	353.56	
EFT46519	17/02/2023	TREVOR EASTWELL	DRIVING WUNDOWIE TO NORTHAM COMMUNITY TRANSPORT FEBRUARY 2023	1		50.00
INV 8	09/02/2023	TREVOR EASTWELL	DRIVING WUNDOWIE TO NORTHAM COMMUNITY TRANSPORT FEBRUARY 2023	1	50.00	
EFT46520	17/02/2023	VERLINDEN'S ELECTRICAL SERVICE PTY LTD	NORTHAM DEPOT REDEVELOPMENT. SUPPLY AND INSTALL ALL ELECTRICAL COMPONENTS INCLUDING ALL TRENCHIN AS PER QUOTE NQ04670REVA. AWARDED FROM VENDOR PANEL REF# VP271464. - PROGRESS CLAIM ONE	1		58,080.00
INV 96713	31/01/2023	VERLINDEN'S ELECTRICAL SERVICE PTY LTD	NORTHAM DEPOT REDEVELOPMENT. SUPPLY AND INSTALL ALL ELECTRICAL COMPONENTS INCLUDING ALL TRENCHIN AS PER QUOTE NQ04670REVA. AWARDED FROM VENDOR PANEL REF# VP271464. - PROGRESS CLAIM ONE	1	58,080.00	
EFT46521	17/02/2023	VISIT BRANDS PTY LTD	300x GALLERY MAGNETS	1		825.00
INV SI-00002902/02/2023		VISIT BRANDS PTY LTD	300x GALLERY MAGNETS	1	825.00	

**Ordinary Council Meeting Minutes
15 March 2023**

Attachment 13.4.1.1

Date: 01/03/2023
Time: 8:24:14AM

Shire of Northam

USER: Louise Harris
PAGE: 38 10

Cheque /EFT No	Date	Name	Invoice Description	Bank Code	INV Amount	Amount
EFT46522	17/02/2023	WA DISTRIBUTORS PTY LTD	NORTHAM AQUATIC CENTRE - KIOSK SUPPLIES	1		522.55
INV 808677	02/02/2023	WA DISTRIBUTORS PTY LTD	NORTHAM AQUATIC CENTRE - KIOSK SUPPLIES	1	281.50	
INV 811371	09/02/2023	WA DISTRIBUTORS PTY LTD	NORTHAM AQUATIC CENTRE - KIOSK SUPPLIES	1	241.05	
EFT46523	17/02/2023	WARRICKSNEWSAGENCY	POCKET NOTE BOOKS, CORRECTION TAPE, SHEET PROTECTORS, HALF SIZE COLOURED PENCILS	1		187.61
INV 69848	06/02/2023	WARRICKSNEWSAGENCY	POCKET NOTE BOOKS, CORRECTION TAPE, SHEET PROTECTORS, HALF SIZE COLOURED PENCILS	1	187.61	
EFT46524	17/02/2023	WESTERN IRRIGATION PTY LTD	COMPLETE PUMP AND MOTOR ASSEMBLY REPLACEMENT FOR HENRY STREET OVAL	1		11,000.00
INV P51294	31/01/2023	WESTERN IRRIGATION PTY LTD	COMPLETE PUMP AND MOTOR ASSEMBLY REPLACEMENT FOR HENRY STREET OVAL	1	11,000.00	
EFT46525	17/02/2023	WESTWIDE AUTO ELECTRICS AND AIR CONDITIONING	REMOVE AND RELOCATE 24V CHARGING POINT FOR NORTHAM CENTRAL 3.4U	1		2,164.50
INV INV-144212/01/2023		WESTWIDE AUTO ELECTRICS AND AIR CONDITIONING	IRISHTOWN 1.4R – ATTEND STATION AND REPLACE BATTERY TERMINALS SUFFERING CORROSION, PLEASE OMIT COSTS AND ALLOW \$300	1	364.50	
INV INV-143613/01/2023		WESTWIDE AUTO ELECTRICS AND AIR CONDITIONING	REMOVE AND RELOCATE 24V CHARGING POINT FOR NORTHAM CENTRAL 3.4U	1	1,800.00	
EFT46526	17/02/2023	WHEATBELT OFFICE & BUSINESS MACHINES / COUNTRY COPIERS - GARDNER T/AS	KEY RINGS, SHINY STAMP & BLU TACK	1		14.90
INV 1085	02/02/2023	WHEATBELT OFFICE & BUSINESS MACHINES / COUNTRY COPIERS - GARDNER T/AS	KEY RINGS, SHINY STAMP & BLU TACK	1	14.90	
EFT46527	17/02/2023	WHEATBELT PRECISION SERVICES - JEFFREY ROBERTS T/AS	IEFJ-949 REPAIR DIFFERENTIAL HOUSING - AS PER QUOTE QU-0059	1		5,212.07
INV INV-021306/02/2023		WHEATBELT PRECISION SERVICES - JEFFREY ROBERTS T/AS	ISOLATION SWITCH / TOGGLE SWITCH	1	13.00	
INV INV-022309/02/2023		WHEATBELT PRECISION SERVICES - JEFFREY ROBERTS T/AS	CLACKLINE LT AUXILLARY PUMP - AS PER QUOTE QU-0061	1	387.95	
INV INV-022009/02/2023		WHEATBELT PRECISION SERVICES - JEFFREY ROBERTS T/AS	INKPEN LT FUEL LEAK - AS PER QUOTE QU-0057	1	418.13	

Ordinary Council Meeting Minutes
15 March 2023

Attachment 13.4.1.1

Date: 01/03/2023
Time: 8:24:14AM

Shire of Northam

USER: Louise Harris
PAGE: 39 10

Cheque /EFT No	Date	Name	Invoice Description	Bank Code	INV Amount	Amount
INV INV-022109/02/2023		WHEATBELT PRECISION SERVICES - JEFFREY ROBERTS T/AS	NORTHAM 3.4 WATER LEAK - AS PER QUOTE QU-0058	1	481.03	
INV INV-022209/02/2023		WHEATBELT PRECISION SERVICES - JEFFREY ROBERTS T/AS	IEFJ-949 REPAIR DIFFERENTIAL HOUSING - AS PER QUOTE QU-0059	1	3,911.96	
EFT46528	21/02/2023	FIRE MITIGATION SERVICES	C.202223-05 - FIRE MITIGATION SERVICES - MAF 2022/23 AS PER CONTRACT - WORKS COMPLETED 16/1/2023 - 20/1/2023	1		62,488.80
INV 0000071131/01/2023		FIRE MITIGATIONSERVICES	C.202223-05 - FIRE MITIGATION SERVICES - MAF 2022/23 AS PER CONTRACT - WORKS COMPLETED 16/1/2023 - 20/1/2023	1	46,569.60	
INV 0000071916/02/2023		FIRE MITIGATIONSERVICES	C.202223-05 - FIRE MITIGATION SERVICES - MAF 2022/23 AS PER CONTRACT - WORKS COMPLETED 2/2/2023 - 15/2/2023	1	15,919.20	
EFT46529	21/02/2023	J & A BUILDING PTY LTD	SUPPLY AND CONSTRUCT NORTHAM SES SHED EXTENSION AS PER CONTRACT C.202021-30 - RELEASE OF 50% RETENTION	1		5,225.00
INV 3421	25/01/2023	J & A BUILDING PTY LTD	SUPPLY AND CONSTRUCT NORTHAM SES SHED EXTENSION AS PER CONTRACT C.202021-30 - RELEASE OF 50% RETENTION	1	5,225.00	
EFT46530	23/02/2023	AUSTRALIAN TAXATION OFFICE - PAYG	PAYG FOR PAY WEEK ENDING 14/02/2023	1		78,478.80
INV PAYG 1414/02/2023		AUSTRALIAN TAXATION OFFICE - PAYG	PAYG FOR PAY WEEK ENDING 14/02/2023	1	78,478.80	
EFT46531	23/02/2023	AUTOPRO NORTHAM	PN1903 - TYRE SEALANT REPAIR	1		32.89
INV 1048225	17/02/2023	AUTOPRO NORTHAM	PN1903 - TYRE SEALANT REPAIR	1	32.89	
EFT46532	23/02/2023	AVON SERVICESPECIALISTS	PN1607 - N577 - PLEASE CONDUCT 120,000KM SERVICE, ADVISE WHEN READY TO COLLECT THIS IS THE DEPUTY FIRE CHIEF VEHICLE.	1		308.50
INV 25097	16/02/2023	AVON SERVICESPECIALISTS	PN1607 - N577 - PLEASE CONDUCT 120,000KM SERVICE, ADVISE WHEN READY TO COLLECT THIS IS THE DEPUTY FIRE CHIEF VEHICLE.	1	308.50	
EFT46533	23/02/2023	AVON VALLEY GARDEN SERVICE	FUEL REDUCTION A15658 25 SELBY STREET NORTHAM	1		297.00

**Ordinary Council Meeting Minutes
15 March 2023**

Attachment 13.4.1.1

Date: 01/03/2023
Time: 8:24:14AM

Shire of Northam

USER: Louise Harris
PAGE: 40 10

Cheque /EFT No	Date	Name	Invoice Description	Bank Code	INV Amount	Amount
INV IV1920	07/02/2023	AVON VALLEY GARDEN SERVICE	FUEL REDUCTION A12390 20 WALLARAT ROADNORTHAM	1	132.00	
INV IV1936	17/02/2023	AVON VALLEY GARDEN SERVICE	FUEL REDUCTION A15658 25 SELBY STREET NORTHAM	1	165.00	
EFT46534	23/02/2023	AVON VALLEY NISSAN & MITSUBISHI AVN NORTHAM PTY LTD T/AS	PN1905 - N11069 - PLEASE CONDUCT 90,000KM SERVICE	1		1,062.11
INV 351784	20/01/2023	AVON VALLEY NISSAN & MITSUBISHI AVN NORTHAM PTY LTD T/AS	PN1905 - N11069 - PLEASE CONDUCT 90,000KM SERVICE	1	1,062.11	
EFT46535	23/02/2023	AVON VALLEY TOYOTA	PN1808 - KILLARA2 - PLEASE CONDUCT A SERVICE THOUGH VEHICLE HAS ONLY TRAVELLED 7127KMS IS HAS NOT BEEN SERVICED SINCE NEW.	1		1,145.09
INVJC14009510/02/2023		AVON VALLEY TOYOTA	PN2005 - N11114 - PLEASE SERVICE - ODOMETER READING IS CURRENTLY 17,395KMS	1	488.97	
INVJC14009510/02/2023		AVON VALLEY TOYOTA	PN1808 - KILLARA2 - PLEASE CONDUCT A SERVICE THOUGH VEHICLE HAS ONLY TRAVELLED 7127KMS IS HAS NOT BEEN SERVICED SINCE NEW.	1	656.12	
EFT46536	23/02/2023	BELINGARNI FABRICATION HOME AND PROPERTY SERVICES	FUEL REDUCTION - VARIOUS CLACKLINE / MOKINE / SPENCERS BROOK	1		3,784.00
INV 987	16/02/2023	BELINGARNI FABRICATION HOME AND PROPERTY SERVICES	FUEL REDUCTION - A913 80 OLIVE ROAD WUNDOWIE / A16191 LOT 104 CORYMBIA CLOSE COPLEY / A1960 245 RAILWAY ROAD CLACKLINE	1	1,276.00	
INV 985	16/02/2023	BELINGARNI FABRICATION HOME AND PROPERTY SERVICES	FUEL REDUCTION - VARIOUS CLACKLINE / MOKINE / SPENCERS BROOK	1	2,178.00	
INV 986	16/02/2023	BELINGARNI FABRICATION HOME AND PROPERTY SERVICES	FUEL REDUCTION - A2278 1 HUNTER ROAD MULUCKINE / A1925 32 CARTER STREET GRASS VALLEY	1	330.00	
EFT46537	23/02/2023	BLACKWELL PLUMBING AND GAS PTY LTD	NORTHAM AERODROME. EMERGENCY REPAIR OF MAINS WATER LEAK OUTSIDE OF NORTHAM AIR SERVICES.	1		555.50
INV INV-277916/02/2023		BLACKWELL PLUMBING AND GAS PTY LTD	NORTHAM AERODROME. EMERGENCY REPAIR OF MAINS WATER LEAK OUTSIDE OF NORTHAM AIR SERVICES.	1	555.50	
EFT46538	23/02/2023	BOLINDA PUBLISHING PTY LTD	LARGE PRINT BOOKS FOR LOCAL STOCK REQUESTS	1		1,329.13
INV 275557	24/10/2022	BOLINDA PUBLISHING PTY LTD	LARGE PRINT BOOKS FOR LOCAL STOCK REQUESTS	1	260.92	

**Ordinary Council Meeting Minutes
15 March 2023**

Attachment 13.4.1.1

Date: 01/03/2023
Time: 8:24:14AM

Shire of Northam

USER: Louise Harris
PAGE: 41 10

Cheque /EFT No	Date	Name	Invoice Description	Bank Code	INV Amount	Amount
INV 284904	10/02/2023	BOLINDA PUBLISHING PTY LTD	LARGE PRINT BOOKS FOR LOCAL STOCK REQUESTS	1	1,068.21	
EFT46539	23/02/2023	BUILDING & ENERGY	MONTHLY BSL FEES COLLECTED FOR THE BUILDING COMMISSION FOR THE MONTH OF JANUARY 2023	1		1,730.48
INV T1080	22/02/2023	BUILDING & ENERGY	MONTHLY BSL FEES COLLECTED FOR THE BUILDING COMMISSION FOR THE MONTH OF JANUARY 2023	1	1,730.48	
EFT46540	23/02/2023	BUILDING AND CONSTRUCTION INDUSTRY TRAINING FUND	MONTHLY BCITF FEES COLLECTED FOR THE CONSTRUCTION TRAINING FUND FOR THE MONTH OF JANUARY 2023	1		63.91
INV T1079	22/02/2023	BUILDING AND CONSTRUCTION INDUSTRY TRAINING FUND	MONTHLY BCITF FEES COLLECTED FOR THE CONSTRUCTION TRAINING FUND FOR THE MONTH OF JANUARY 2023	1	63.91	
EFT46541	23/02/2023	BUNNINGS BUILDING SUPPLIES P/L	INKPEN TIP, SUPPLY PADLOCKS AND LENGTHOF CHAIN.	1		407.95
INV 2182/003	07/02/2023	BUNNINGS BUILDING SUPPLIES P/L	1X 8.5KG SWAP 'N' GO GAS BOTTLE	1	28.38	
INV 2182/002	10/02/2023	BUNNINGS BUILDING SUPPLIES P/L	INKPEN TIP, SUPPLY PADLOCKS AND LENGTHOF CHAIN.	1	154.94	
INV 2182/003	14/02/2023	BUNNINGS BUILDING SUPPLIES P/L	2LT LIQUID FERTILIZER, SEASOL & WETTASOIL	1	83.74	
INV 2182/003	15/02/2023	BUNNINGS BUILDING SUPPLIES P/L	MULTI PURPOSE CRC	1	40.65	
INV 2182/003	16/02/2023	BUNNINGS BUILDING SUPPLIES P/L	DECKING OIL , DROP SHEET & PAIN BRUSHES	1	83.74	
INV 2182/003	17/02/2023	BUNNINGS BUILDING SUPPLIES P/L	CABLE TIES	1	16.50	
EFT46542	23/02/2023	CADD'S FASHIONS	RANGER WORK SHIRTS	1		518.55
INV 23-00001	20/02/2023	CADD'S FASHIONS	BIZLEY CARGO BPC6007 SIZE 87SHORT	1	146.00	
INV 23-00001	20/02/2023	CADD'S FASHIONS	RANGER WORK SHIRTS	1	372.55	
EFT46543	23/02/2023	CENTRAL MOBILE MECHANICAL REPAIRS	PN1006 STEEL DRUM ROLLER 4300HR SERVICE MONDAY 12/12/2022	1		2,899.27
INV 0000430007	02/2023	CENTRAL MOBILE MECHANICAL REPAIRS	PN1809 REGO N.004 - JCB BACKHOE SERVICE 750HR 06/02/2023	1	1,446.39	
INV 0000430914	02/2023	CENTRAL MOBILE MECHANICAL REPAIRS	PN1006 STEEL DRUM ROLLER 4300HR SERVICE MONDAY 12/12/2022	1	1,452.88	
EFT46544	23/02/2023	CENTRAL REGIONAL TAFE	2022/2023 EDUCATIONAL PRIZES & DONATIONS ALLOCATION	1		1,100.00

**Ordinary Council Meeting Minutes
15 March 2023**

Attachment 13.4.1.1

Date: 01/03/2023
Time: 8:24:14AM

Shire of Northam

USER: Louise Harris
PAGE: 42 10

Cheque /EFT No	Date	Name	Invoice Description	Bank Code	INV Amount	Amount
INV I0021529	14/02/2023	CENTRAL REGIONAL TAFE	2022/2023 EDUCATIONAL PRIZES & DONATIONS ALLOCATION	1	1,100.00	
EFT46545	23/02/2023	CJD EQUIPMENT PTY LTD	PN1706 JD GRADER - 2021CE - TIP,SCARIFIER X 20	1		652.30
INV 0025748513	02/2023	CJD EQUIPMENT PTY LTD	PN1314 VOLVO G930 GRADER - 2021CE - TIP,SCARIFIER	1	154.00	
INV 0025748513	02/2023	CJD EQUIPMENT PTY LTD	PN1314 VOLVO G930 GRADER - 2021CE - TIP,SCARIFIER	1	231.00	
INV 0025781417	02/2023	CJD EQUIPMENT PTY LTD	PN1706 JD GRADER - 2021CE - TIP,SCARIFIER X 20	1	267.30	
EFT46546	23/02/2023	COMMUNITY RESOURCE LIMITED T/AS SOFT LANDING	MATTRESS DELIVERY FOR RECYCLING	1		2,057.00
INV INV7357	31/01/2023	COMMUNITY RESOURCE LIMITED T/AS SOFT LANDING	MATTRESS DELIVERY FOR RECYCLING	1	2,057.00	
EFT46547	23/02/2023	CORSIGN WA PTY LTD	T5-1A DETOUR (CENTRED) 1200X300 / T2-4 ROAD CLOSED 1800X300 B/Y CL400WZ REFLECTIVE BOXED EDGE & MAGNETIC ARROWS	1		633.60
INV 0007259810	02/2023	CORSIGN WA PTY LTD	T5-1A DETOUR (CENTRED) 1200X300 / T2-4 ROAD CLOSED 1800X300 B/Y CL400WZ REFLECTIVE BOXED EDGE & MAGNETIC ARROWS	1	633.60	
EFT46548	23/02/2023	DCM CARPENTRY AND MAINTENANCE PTY LTD	TOWN HALL. REPLACE SAGGING KITCHEN CEILING AS PER QUOTE1301.	1		11,264.00
INV 1001	08/02/2023	DCM CARPENTRY AND MAINTENANCE PTY LTD	FABRICATE STEEL GATES WITH WHITE MELAMINE IN FILL PANELS. 4 X GATES FOR TOP OF THE GRANDSTAND AT NORTHAM REC CENTRE.	1	1,881.00	
INV 1002	08/02/2023	DCM CARPENTRY AND MAINTENANCE PTY LTD	TOWN HALL. REPLACE SAGGING KITCHEN CEILING AS PER QUOTE1301.	1	7,029.00	
INV 1003	08/02/2023	DCM CARPENTRY AND MAINTENANCE PTY LTD	BOUNDARY FENCING AT NORTHAM AIRFIELD	1	2,354.00	
EFT46549	23/02/2023	E. & M.J. ROSHER PTY LTD	PN1904 REGO N.4468 - KUBOTA K5691-62110 SPRING GAS	1		68.09
INV 1454173	17/02/2023	E. & M.J. ROSHER PTY LTD	PN1904 REGO N.4468 - KUBOTA K5691-62110 SPRING GAS	1	68.09	
EFT46550	23/02/2023	ENVIRO PIPES PTY LTD	HDPE PIPES FOR THE NORTHAM DEPOT DEVELOPMENT DRAINAGE AS PER QUOTE Q72285	1		9,402.55
INV 57807	15/02/2023	ENVIRO PIPES PTY LTD	HDPE PIPES FOR THE NORTHAM DEPOT DEVELOPMENT DRAINAGE AS PER QUOTE Q72285	1	9,402.55	

Ordinary Council Meeting Minutes
15 March 2023

Attachment 13.4.1.1

Date: 01/03/2023
Time: 8:24:14AM

Shire of Northam

USER: Louise Harris
PAGE: 43 10

Cheque /EFT No	Date	Name	Invoice Description	Bank Code	INV Amount	Amount
EFT46551	23/02/2023	G.S. BEVERIDGE & L.P. NOTTLE	TOWN HALL. REPLACE REAR DOORS AS FALLING APART AS PER QUOTE.	1		6,127.00
INV 390	13/02/2023	G.S. BEVERIDGE & L.P. NOTTLE	FLUFFY DUCKLINGS DAY CARE. WATERPROOF AND TILE BATHROOMS AS PER SITE VISIT.	1	1,474.00	
INV 384	13/02/2023	G.S. BEVERIDGE & L.P. NOTTLE	OLD POST OFFICE. REPLACE 6 X BROKEN DECKING BOARDS ON LOADING RAMP.	1	297.00	
INV 389	13/02/2023	G.S. BEVERIDGE & L.P. NOTTLE	TOWN HALL. REPLACE REAR DOORS AS FALLING APART AS PER QUOTE.	1	2,200.00	
INV 388	13/02/2023	G.S. BEVERIDGE & L.P. NOTTLE	CLACKLINE & WUNDOWIE TOILETS - INSTALL NEW MALE AND FEMALE SIGNS ON WALL NEAR ENTRY.	1	308.00	
INV 386	13/02/2023	G.S. BEVERIDGE & L.P. NOTTLE	SOUND SHELL. REPIAR FLAG POLES FOR AUSTRALIA DAY.	1	264.00	
INV 385	13/02/2023	G.S. BEVERIDGE & L.P. NOTTLE	BERNARD PARK TOILETS. REMOVE GRAFFITI FROM WALLS.	1	220.00	
INV 391	13/02/2023	G.S. BEVERIDGE & L.P. NOTTLE	FLUFFY DUCKS. CLEAN OUT GUTTERS.	1	99.00	
INV 392	13/02/2023	G.S. BEVERIDGE & L.P. NOTTLE	BERNARD PARK TOILETS. INSTALL NEW TOILET ROLL HOLDERS.	1	440.00	
INV 383	13/02/2023	G.S. BEVERIDGE & L.P. NOTTLE	CLACKLINE TOILETS. REPLACE VANDALISED TOILET SEATS.	1	165.00	
INV 387	13/02/2023	G.S. BEVERIDGE & L.P. NOTTLE	VISITORS CENTRE. SAND AND REVARNISH ALL TIMBER RAILS.	1	660.00	
EFT46552	23/02/2023	GOODYEAR & DUNLOP TYRES (AUST) PTY LTD	TYRE FITTING - 1CIG323	1		871.78
INV 641288422/12/2022		GOODYEAR & DUNLOP TYRES (AUST) PTY LTD	TYRE FITTING - 1CIG323	1	507.93	
INV 6412942708/02/2023		GOODYEAR & DUNLOP TYRES (AUST) PTY LTD	PN1911 - N.4490 - PLEASE FIT 2 X CN215/65R16C 109/107R COMMERCIAL TYRES,INCLUDES FITTING, BALANCING, ALIGNMENT & DISPOSAL OF OLD TYRES	1	363.85	
EFT46553	23/02/2023	HERSEY'S SAFETY PTY LTD	LITE GRIP GARDEN GLOVES, SPRAY MARK CANS PAINT,9V BATTERY'S, EAR PLUGS	1		494.75
INV 48676	15/02/2023	HERSEY'S SAFETY PTY LTD	LITE GRIP GARDEN GLOVES, SPRAY MARK CANS PAINT,9V BATTERY'S, EAR PLUGS	1	494.75	
EFT46554	23/02/2023	INTERSECTIONAL LINEMARKERS PTY LTD	C.202223-04 - SPENCERS BROOK ROAD AUDIBLE EDGE LINE MARKING AS PER CONTRACT - 50% RETENTION RELEASE	1		6,803.08

**Ordinary Council Meeting Minutes
15 March 2023**

Attachment 13.4.1.1

Date: 01/03/2023
Time: 8:24:14AM

Shire of Northam

USER: Louise Harris
PAGE: 44 10

Cheque /EFT No	Date	Name	Invoice Description	Bank Code	INV Amount	Amount
INV 10865	30/12/2022	INTERSECTIONAL LINEMARKERS PTY LTD	C.202223-04 - SPENCERS BROOK ROAD AUDIBLE EDGE LINE MARKING AS PER CONTRACT - 50% RETENTION RELEASE	1	6,803.08	
EFT46555	23/02/2023	JASON SIGNMAKERS	STREET BLADE DOUBLE SIDED SON SPECS HILL RD	1		46.02
INV 27300	13/02/2023	JASON SIGNMAKERS	STREET BLADE DOUBLE SIDED SON SPECS HILL RD	1	46.02	
EFT46556	23/02/2023	KLEENHEAT GAS	GAS FOR NORTHAM SWIMMING POOL HEATERS FOR OCTOBER 2022	1		3,806.86
INV 2202494325/10/2022		KLEENHEAT GAS	GAS FOR NORTHAM SWIMMING POOL HEATERS FOR OCTOBER 2022	1	1,969.35	
INV 2206626407/02/2023		KLEENHEAT GAS	GAS FOR NORTHAM SWIMMING POOL HEATERS FOR FEBRUARY 2023	1	1,837.51	
EFT46557	23/02/2023	LANDGATE	GROSS RENTAL VALUATIONS CHARGEABLE SCHEDULE G2022/14 FROM 26/11/2022 TO 23/12/2022	1		515.68
INV 381188	23/01/2023	LANDGATE	GROSS RENTAL VALUATIONS CHARGEABLE SCHEDULE G2022/14 FROM 26/11/2022 TO 23/12/2022	1	338.28	
INV 381231	25/01/2023	LANDGATE	RURAL UV'S CHARGEABLE SCHEDULE R2023/1 FROM 26/11/2022 TO 20/01/2023	1	177.40	
EFT46558	23/02/2023	LUME BRASSERIE - MADEELA PLT/AS	CATERING FOR COUNCIL FORUM - 08TH FEBRUARY 2023 (BARRAMUNDI)	1		900.00
INV 69944	16/02/2023	LUME BRASSERIE - MADEELA PLT/AS	CATERING FOR COUNCIL FORUM - 08TH FEBRUARY 2023 (BARRAMUNDI)	1	900.00	
EFT46559	23/02/2023	MAYBERRY HAMMOND & CO	LEASE AGREEMENT - HANGAR SITE 17	1		1,309.00
INV 44900	10/02/2023	MAYBERRY HAMMOND & CO	LEASE AGREEMENT - HANGAR SITE 17	1	660.00	
INV 44901	10/02/2023	MAYBERRY HAMMOND & CO	LEASE FOR AVON VALLEY VINTAGE VEHICLE ASSOCIATION	1	649.00	
EFT46560	23/02/2023	MCLEODS BARRISTERS & SOLICITORS	LEGAL ADVICE - PROVISION OF DOCUMENTS	1		4,887.30
INV 128243	31/01/2023	MCLEODS BARRISTERS & SOLICITORS	ONGOING LEGAL CONSULTATION COSTS - 4 HOVEA CRESCENT	1	479.60	

Ordinary Council Meeting Minutes
15 March 2023

Attachment 13.4.1.1

Date: 01/03/2023
Time: 8:24:14AM

Shire of Northam

USER: Louise Harris
PAGE: 45 10

Cheque /EFT No	Date	Name	Invoice Description	Bank Code	INV Amount	Amount
INV 128244	31/01/2023	MCLEODS BARRISTERS & SOLICITORS	ONGOING LEGAL COSTS - 3 JESSUP TERRACE	1	1,558.70	
INV 128364	15/02/2023	MCLEODS BARRISTERS & SOLICITORS	LEGAL ADVICE - PROVISION OF DOCUMENTS	1	2,200.00	
INV 128377	16/02/2023	MCLEODS BARRISTERS & SOLICITORS	LEGAL ADVICE - CEO CONTRACT / ATTENDING REVIEW COMMITTEE MEETING	1	649.00	
EFT46561	23/02/2023	MILBRIDGE PTY LTD AS TRUSTEE FOR MX MAV TRUST	RELIEF TOWN PLANNER - 3 DAYS PER WEEK, 14 WEEKS	1		5,826.70
INV INV - 00516	02/2023	MILBRIDGE PTY LTD AS TRUSTEE FOR MX MAV TRUST	RELIEF TOWN PLANNER - 3 DAYS PER WEEK, 14 WEEKS	1	5,826.70	
EFT46562	23/02/2023	MODERN TEACHING AIDS PTY LTD	SUPPLIES FOR BABY RHYME TIME, ACTIVITY TIME AND LEGO CLUB - BABY SHAKERS AND DUPLO	1		398.45
INV 4525465920	01/2023	MODERN TEACHING AIDS PTY LTD	SUPPLIES FOR BABY RHYME TIME, ACTIVITY TIME AND LEGO CLUB - BABY SHAKERS AND DUPLO	1	398.45	
EFT46563	23/02/2023	NORTHAM BETTA HOME LIVING	NEW FRIDGE FOR COUNCIL CHAMBERS	1		729.00
INV 2001005114	02/2023	NORTHAM BETTA HOME LIVING	NEW FRIDGE FOR COUNCIL CHAMBERS	1	729.00	
EFT46564	23/02/2023	NORTHAM COUNTRY CLUB INC	SENIOR SPORT FUNDING - PHILIP CUTMORE	1		100.00
INV 4574	17/02/2023	NORTHAM COUNTRY CLUB INC	SENIOR SPORT FUNDING - PHILIP CUTMORE	1	100.00	
EFT46565	23/02/2023	NORTHAM FEED & HIRE	SWAN FOOD & OTHER MISCELLANEOUS ITEMS FEB 2023	1		344.00
INV 0000468301	02/2023	NORTHAM FEED & HIRE	SWAN FOOD & OTHER MISCELLANEOUS ITEMS FEBRUARY 2023	1	57.00	
INV 0000468403	02/2023	NORTHAM FEED & HIRE	SWAN FOOD & OTHER MISCELLANEOUS ITEMS FEB 2023	1	22.00	
INV 0000468506	02/2023	NORTHAM FEED & HIRE	SWAN FOOD & OTHER MISCELLANEOUS ITEMS FEB 2023	1	57.00	
INV 0000468706	02/2023	NORTHAM FEED & HIRE	SWAN FOOD & OTHER MISCELLANEOUS ITEMS FEB 2023	1	50.00	
INV 0000468614	02/2023	NORTHAM FEED & HIRE	SWAN FOOD & OTHER MISCELLANEOUS ITEMS FEB 2023	1	22.00	
INV 0000470215	02/2023	NORTHAM FEED & HIRE	SWAN FOOD & OTHER MISCELLANEOUS ITEMS FEB 2023	1	92.00	
INV 0000470317	02/2023	NORTHAM FEED & HIRE	SWAN FOOD & OTHER MISCELLANEOUS ITEMS feb 2023	1	44.00	
EFT46566	23/02/2023	NORTHAM LIQUOR BARONS	DRINKS FOR COUNCIL CHAMBERS	1		191.94
INV 1201-418	14/02/2023	NORTHAM LIQUOR BARONS	DRINKS FOR COUNCIL CHAMBERS	1	191.94	

**Ordinary Council Meeting Minutes
15 March 2023**

Attachment 13.4.1.1

Date: 01/03/2023
Time: 8:24:14AM

Shire of Northam

USER: Louise Harris
PAGE: 46 10

Cheque /EFT No	Date	Name	Invoice Description	Bank Code	INV Amount	Amount
EFT46567	23/02/2023	NORTHAM TYREPOWER	PN1706 - JD GRADER TYRE PUNCTURE REPAIR	1		150.00
INV 147374	20/02/2023	NORTHAM TYREPOWER	PN1706 - JD GRADER TYRE PUNCTURE REPAIR	1	150.00	
EFT46568	23/02/2023	PERTH ENERGY PTYLTD	ELECTRICITY CHARGES FOR ACCOUNT 601148 - 182 FITZGERALD ST, NORTHAM (POP UP SHOP) - STATEMENT NO: 2319760	1		405.65
INV 2319760	15/02/2023	PERTH ENERGY PTYLTD	ELECTRICITY CHARGES FOR ACCOUNT 601148 - 182 FITZGERALD ST, NORTHAM (POP UP SHOP) - STATEMENT NO: 2319760	1	405.65	
EFT46569	23/02/2023	PLANNING INSTITUTE AUSTRALIA	PLANNING OFFICER - CLASSIC ADVERTISEMENT	1		695.00
INV ED2302003/02/2023		PLANNING INSTITUTE AUSTRALIA	PLANNING OFFICER - CLASSIC ADVERTISEMENT	1	360.00	
INV 149175	08/02/2023	PLANNING INSTITUTE AUSTRALIA	KIM HAMPTON: REGISTRATION FEE (PLANET WA INTRODUCTION TO PLANNING LAW - 28 MAR 23	1	335.00	
EFT46570	23/02/2023	PROFESSIONAL LOCKSERVICE	ADMIN BUILDING & VISITORS CENTRE - REPAIR REAR DOOR EXTERNAL HANDLES	1		1,280.02
INV 0010845730/01/2023		PROFESSIONALLOCKSERVICE	WUNDOWIE POOL. SUPPLY 4 X C10 WUNDOWIE POOL KEYS.	1	104.50	
INV 0010852116/02/2023		PROFESSIONALLOCKSERVICE	ADMIN BUILDING & VISITORS CENTRE - REPAIR REAR DOOR EXTERNAL HANDLES	1	1,175.52	
EFT46571	23/02/2023	QUBE LOGISTICS (WA) PTY LTD	DELIVERY OF TWO x 920KG CHLORINE GAS TO WASTE WATER TREATMENT PLANT	1		1,320.00
INV TS22126815/02/2023		QUBE LOGISTICS (WA) PTY LTD	DELIVERY OF TWO x 920KG CHLORINE GAS TO WASTE WATER TREATMENT PLANT	1	1,320.00	
EFT46572	23/02/2023	ROOGENIC - ROO TEA PTYLTD	6 ANTI INFLAMMATORY TEA 6 SLEEP TEABAGS 6 ORANGE & LEMON MYRTLE 6 GUBINGE KAKADU PLUM	1		273.86
INV WS-000009/02/2023		ROOGENIC - ROO TEA PTYLTD	6 ANTI INFLAMMATORY TEA 6 SLEEP TEABAGS 6 ORANGE & LEMON MYRTLE 6 GUBINGE KAKADU PLUM	1	273.86	
EFT46573	23/02/2023	SHENTON PUMPS - SHENTON ENTERPRISES PTY LTD T/AS	PV2100 MANUAL VACUUM POOL CLEANER	1		4,389.00

**Ordinary Council Meeting Minutes
15 March 2023**

Attachment 13.4.1.1

Date: 01/03/2023
Time: 8:24:14AM

Shire of Northam

USER: Louise Harris
PAGE: 47 10

Cheque /EFT No	Date	Name	Invoice Description	Bank Code	INV Amount	Amount
INV 190947	15/02/2023	SHENTON PUMPS - SHENTON ENTERPRISES PTY LTD T/AS	PV2100 MANUAL VACUUM POOL CLEANER	1	4,389.00	
EFT46574	23/02/2023	SOUTHERN CROSS AUSTEREO PTY LTD	ONGOING RADIO ADS 1/1/2023 - 31/1/2023 522 X 30 SECOND RADIO COMMERCIALS 2 PER DAY OVER TRIPLE M NORTHAM	1		1,394.80
INV 7143437831/01/2023		SOUTHERN CROSS AUSTEREO PTY LTD	522 X 30 SECOND RADIO COMMERCIALS 2 PER DAY ON HIT FM NORTHAM AND MERREDIN ONGOING RADIO ADS 1/1/2023 - 31/1/2023 522 X 30 SECOND RADIO COMMERCIALS 2 PER DAY OVER TRIPLE M NORTHAM 522 X 30 SECOND RADIO COMMERCIALS 2 PER DAY ON HIT FM NORTHAM AND MERREDIN	1	1,394.80	
EFT46575	23/02/2023	SPECIALISED TREESERVICE	NORTHAM TOWNSITE STREET TREES PRUNING AS PER C.201819-09 - WEEK ENDING 17/2/2023	1		20,306.25
INV 4032	20/02/2023	SPECIALISED TREESERVICE	NORTHAM TOWNSITE STREET TREES PRUNING AS PER C.201819-09 - WEEK ENDING 17/2/2023	1	20,306.25	
EFT46576	23/02/2023	SYNERGY	168614990 STREETLIGHTING - 25/06/2022 to 24/01/2023	1		30,776.96
INV 9152416401/02/2023		SYNERGY	915241640 AUXILLARY LIGHTING - 28/12/2022 to 27/01/2023		141.98	
INV 1686149901/02/2023		SYNERGY	168614990 STREETLIGHTING - 25/06/2022 to 24/01/2023	1	26,070.59	
INV 3575496916/02/2023		SYNERGY	357549690 KILLARA DAYCARE CENTRE - 19/01/2023 to 15/02/2023		1,127.87	
INV 3614739616/02/2023		SYNERGY	361473960 OLD NORTHAM POOL - GREAT EASTERN HIGHWAY - 19/01/2023 to 15/02/2023		301.57	
INV 1365377416/02/2023		SYNERGY	136537740 AIRPORT - 19/01/2023 to 15/02/2023		1,035.11	
INV 7968413416/02/2023		SYNERGY	796841340 SHIRE ADMINISTRATION BUILDING - 19/01/2023 to 15/02/2023		902.46	
INV 8110294716/02/2023		SYNERGY	811029470 WUNDOWIE SWIMMING POOL - 19/01/2023 to 15/02/2023		842.06	
INV 3616702516/02/2023		SYNERGY	361670250 NORTHAM LIBRARY - 19/01/2023 to 15/02/2023		355.32	
EFT46577	23/02/2023	TELSTRA LIMITED	TELSTRA CHARGES - JANUARY 2023 - ADMIN INTERNET	1		14,134.10
INV 2726009204/02/2023		TELSTRA LIMITED	TELSTRA CHARGES - JANUARY 2023 - HARVEST BAN	1	4,146.55	

**Ordinary Council Meeting Minutes
15 March 2023**

Attachment 13.4.1.1

Date: 01/03/2023
Time: 8:24:14AM

Shire of Northam

USER: Louise Harris
PAGE: 48 10

Cheque /EFT No	Date	Name	Invoice Description	Bank Code	INV Amount	Amount
INV 2726008910/02/2023		TELSTRA LIMITED	TELSTRA CHARGES - JANUARY 2023 - COUNCILLOR IPADS / ADMIN / FINANCE / CESM / BUSH FIRES / RANGERS / CCTV / HEALTH / KILLARA / LANDFILL / PLANNING / WUNDOWIE POOL / NORTHAM LIBRARY / CREATE 298 / BKB / ENGINEERING / BUILDING / VC / REC CENTRE / SES	1	2,857.81	
INV 2726009010/02/2023		TELSTRA LIMITED	TELSTRA CHARGES - JANUARY 2023 - ADMIN / FINANCE / BKB / ENGINEERING / REC CENTRE	1	149.77	
INV 2258398814/02/2023		TELSTRA LIMITED	TELSTRA CHARGES - JANUARY 2023 - ADMIN INTERNET	1	5,955.86	
INV 9026075017/02/2023		TELSTRA LIMITED	TELSTRA CHARGES - JANUARY 2023 - ADMIN / FINANCE / ADMIN INTERNET / HARVEST BAN / LANDFILL / WUNDOWIE POOL / WUNDOWIE LIBRARY / CREATE 298 / ENGINEERING / LANDFILL INTERNET / REC CENTRE / CESM / BUSHFIRES	1	1,024.11	
EFT46578	23/02/2023	THE WORKWEAR GROUP	CAT5BF-BKP-XL ANGLED ZIP CARDIGAN BLACK UNIFORM M.PAUL	1		103.96
INV 1418633822/07/2022		THE WORKWEAR GROUP	CAT5BF-BKP-XL ANGLED ZIP CARDIGAN BLACK UNIFORM M.PAUL	1	103.96	
EFT46579	23/02/2023	TOTAL TOOLS MIDLAND	MAKITA JACK HAMMER 1317C	1		1,099.00
INV 326174	14/02/2023	TOTAL TOOLS MIDLAND	MAKITA JACK HAMMER 1317C	1	1,099.00	
EFT46580	23/02/2023	TPG TELECOM - ACCOUNT2000050690	TPG CHARGES - JANUARY 2023 - ADMIN / FINANCE / BKB / CESM / CREATE 298 / ENGINEERING / HEALTH / BUILDING / KILLARA / NORTHAM & WUNDOWIE LIBRARY / PLANNING / RANGERS / REC CENTRE / VC / IT	1		9,516.11
INV 1872148601/02/2023		TPG TELECOM - ACCOUNT2000050690	TPG CHARGES - JANUARY 2023 - ADMIN / FINANCE / BKB / CESM / CREATE 298 / ENGINEERING / HEALTH / BUILDING / KILLARA / NORTHAM & WUNDOWIE LIBRARY / PLANNING / RANGERS / REC CENTRE / VC / IT	1	9,516.11	
EFT46581	23/02/2023	TPG TELECOM - ACCOUNT 2000054211	TPG CHARGES - JANUARY 2023 - CREATE 298 / SES / BFB	1		705.52
INV 1871265501/02/2023		TPG TELECOM - ACCOUNT 2000054211	TPG CHARGES - JANUARY 2023 - CREATE 298 / SES / BFB	1	705.52	
EFT46582	23/02/2023	TYRECYCLE PTY LTD	PICK UP AND RECYCLE TYRES - OLD QUARRY LANDFILL AND TRANSFER STATION	1		3,417.52

**Ordinary Council Meeting Minutes
15 March 2023**

Attachment 13.4.1.1

Date: 01/03/2023
Time: 8:24:14AM

Shire of Northam

USER: Louise Harris
PAGE: 49 10

Cheque /EFT No	Date	Name	Invoice Description	Bank Code	INV Amount	Amount
INV 100168	02/02/2023	TYRECYCLE PTY LTD	PICK UP AND RECYCLE TYRES - OLD QUARRY LANDFILL AND TRANSFER STATION	1	3,417.52	
EFT46583	23/02/2023	TYREPOWER LTD	PN1908 REGO N11657 - PUNCTURE REPAIR	1		35.20
INV 8265.147314	02/2023	TYREPOWER LTD	PN1908 REGO N11657 - PUNCTURE REPAIR	1	35.20	
EFT46584	23/02/2023	WA CONTRACT RANGER SERVICES	MANAGMENT OF SHIRE OF NORTHAM DOG IMPOUND FACILITY 6/2/2023 - 17/2/2023	1		1,320.00
INV 0000452519	02/2023	WA CONTRACT RANGER SERVICES	MANAGMENT OF SHIRE OF NORTHAM DOG IMPOUND FACILITY 6/2/2023 - 17/2/2023	1	1,320.00	
EFT46585	23/02/2023	WARRICKS NEWSAGENCY	2023 DIARIES	1		951.28
INV 68903	14/11/2022	WARRICKS NEWSAGENCY	2023 DIARIES	1	414.22	
INV 69090	23/11/2022	WARRICKS NEWSAGENCY	LAMINATING POUCHES, STAPLER, SCISSORS, STICKY NOTES,BINDING COVERS & PENS	1	284.44	
INV 98763	18/01/2023	WARRICKS NEWSAGENCY	NOTEBOOKS, HIGHLIGHTERS, PETTY CASH VOUCHER BOOKS,	1	252.62	
EFT46586	23/02/2023	WCP CIVIL PTY LTD	C.202021-09 - REHAB OF OLIVER & WELLINGTON STREET - FINAL RELEASE OF DEFECTS LIABILITY RETENTION	1		14,821.58
INV T1576	22/02/2023	WCP CIVIL PTY LTD	C.202021-09 - REHAB OF OLIVER & WELLINGTON STREET - FINAL RELEASE OF DEFECTS LIABILITY RETENTION	1	14,821.58	
EFT46587	23/02/2023	WESTERN AUSTRALIAN TREASURY CORPORATION	LOAN NO. 228 INTEREST PAYMENT -	1		135,494.07
INV 228	23/02/2023	WESTERN AUSTRALIAN TREASURY CORPORATION	LOAN NO. 228 INTEREST PAYMENT -		135,494.07	
EFT46588	23/02/2023	WESTWIDE AUTO ELECTRICS AND AIR CONDITIONING	PN1805 REGO N.4012 - SUPPLY AND FIT INVERTER AS PER QUOTE QU-0102	1		13,272.50
INV INV-144920	12/2022	WESTWIDE AUTO ELECTRICS AND AIR CONDITIONING	LIGHT VEHICLES - UHF, ANTENNA, SUNDRIES AND INSTALLATION (2HRS) PN1509	1	1,078.75	
INV INV-144620	12/2022	WESTWIDE AUTO ELECTRICS AND AIR CONDITIONING	PN1502- REPLACE UHF, PN1910 - REPLACE ANTENNA, PN1003 - REPLACE ANTENNA	1	1,051.75	
INV INV-145505	01/2023	WESTWIDE AUTO ELECTRICS AND AIR CONDITIONING	HEAVY VEHICLE (24V) - UHF, ANTENNA, BRACKET, SUNDRIES, VOLTAGE REDUCER (24V-12V) AND INSTALLATION (3HRS) - PN1913	1	897.50	

**Ordinary Council Meeting Minutes
15 March 2023**

Attachment 13.4.1.1

Date: 01/03/2023
Time: 8:24:14AM

Shire of Northam

USER: Louise Harris
PAGE: 50 10

Cheque /EFT No	Date	Name	Invoice Description	Bank Code	INV Amount	Amount
INV INV-145505/01/2023		WESTWIDE AUTO ELECTRICS AND AIR CONDITIONING	LIGHT VEHICLES - UHF, ANTENNA, SUNDRIES AND INSTALLATION (2HRS) PN1602	1	707.50	
INV INV-146005/01/2023		WESTWIDE AUTO ELECTRICS AND AIR CONDITIONING	HEAVY VEHICLE (24V) - UHF, ANTENNA, BRACKET, SUNDRIES, VOLTAGE REDUCER (24V-12V) AND INSTALLATION (3HRS) PN1612	1	897.50	
INV INV-146005/01/2023		WESTWIDE AUTO ELECTRICS AND AIR CONDITIONING	LIGHT VEHICLES - UHF, ANTENNA, SUNDRIES AND INSTALLATION (2HRS) PN1407	1	707.50	
INV INV-146105/01/2023		WESTWIDE AUTO ELECTRICS AND AIR CONDITIONING	HEAVY VEHICLES (12V) - UHF, ANTENNA, BRACKET, SUNDRIES AND INSTALLATION (2.5HRS) PN1511	1	707.50	
INV INV-147217/02/2023		WESTWIDE AUTO ELECTRICS AND AIR CONDITIONING	HEAVY VEHICLE (24V) - UHF, ANTENNA, BRACKET, SUNDRIES, VOLTAGE REDUCER (24V-12V) AND INSTALLATION (3HRS) PN1914	1	897.50	
INV INV-147117/02/2023		WESTWIDE AUTO ELECTRICS AND AIR CONDITIONING	LIGHT VEHICLES - UHF, ANTENNA, SUNDRIES AND INSTALLATION (2HRS) PN2020	1	707.50	
INV INV-147217/02/2023		WESTWIDE AUTO ELECTRICS AND AIR CONDITIONING	HEAVY VEHICLE (24V) - UHF, ANTENNA, BRACKET, SUNDRIES, VOLTAGE REDUCER (24V-12V) AND INSTALLATION (3HRS) PN2107	1	897.50	
INV INV-147217/02/2023		WESTWIDE AUTO ELECTRICS AND AIR CONDITIONING	HEAVY VEHICLES (12V) - UHF, ANTENNA, BRACKET, SUNDRIES AND INSTALLATION (2.5HRS) PN1305	1	770.00	
INV INV-147217/02/2023		WESTWIDE AUTO ELECTRICS AND AIR CONDITIONING	PN2206 REGO 1TY1946 - SUPPLY AND WIRE AN 'ELEC BRAKE' UNIT INTO TRAILER	1	1,255.00	
INV INV-146917/02/2023		WESTWIDE AUTO ELECTRICS AND AIR CONDITIONING	PN1805 REGO N.4012 - SUPPLY AND FIT INVERTER AS PER QUOTE QU-0102	1	2,697.00	
EFT46589	23/02/2023	WOOLWORTHS GROUP LIMITED (WOOLWORTHS GROUP)	KILLARA CONSUMABLES -15/02/2023	1		594.14
INV TI-01A2104/02/2023		WOOL WORTHS GROUP LIMITED (WOOLWORTHS GROUP)	KILLARA CONSUMABLES -04/02/2023		182.87	
INV TI-01A2108/02/2023		WOOL WORTHS GROUP LIMITED (WOOLWORTHS GROUP)	KILLARA CONSUMABLES -08/02/2023		94.70	
INV TI-01A2115/02/2023		WOOL WORTHS GROUP LIMITED (WOOLWORTHS GROUP)	KILLARA CONSUMABLES -15/02/2023		316.57	
DD18865.1	03/02/2023	TENNANT AUSTRALIA	RECREATION CENTRE LEASE FEE CLEANING EQUIPMENT FEBRUARY 2023	1		573.75
INV FEBRUA03/02/2023		TENNANT AUSTRALIA	RECREATION CENTRE LEASE FEE CLEANING EQUIPMENT FEBRUARY 2023	1	573.75	

**Ordinary Council Meeting Minutes
15 March 2023**

Attachment 13.4.1.1

Date: 01/03/2023
Time: 8:24:14AM

Shire of Northam

USER: Louise Harris
PAGE: 51 10

Cheque /EFT No	Date	Name	Invoice Description	Bank Code	INV Amount	Amount
DD18886.1	09/02/2023	BANKWEST	JASON WHITEAKER MASTERCARD 21/12/2022 TO 20/01/2023	1		2,089.32
INV S PATTE	09/02/2023	BANKWEST	SCOTT PATTERSON MASTERCARD 21/12/2022 TO 20/01/2023	1	266.45	
INV J METCA	09/02/2023	BANKWEST	JOANNE METCALF MASTERCARD 21/12/2022 TO 20/01/2023	1	543.22	
INV C YOUN	09/02/2023	BANKWEST	COLIN YOUNG MASTERCARD 21/12/2022 TO 22/01/2023	1	496.96	
INV C HUNT	09/02/2023	BANKWEST	CHADD HUNT MASTERCARD 21/12/2022 TO 20/01/2023	1	532.50	
INV J WHITE	09/02/2023	BANKWEST	JASON WHITEAKER MASTERCARD 21/12/2022 TO 20/01/2023	1	250.19	
DD18910.1	14/02/2023	AWARE SUPER	PAYROLL DEDUCTIONS	1		30,793.36
INV SUPER	14/02/2023	AWARE SUPER	SUPERANNUATION CONTRIBUTIONS	1	27,067.34	
INV DEDUCT	14/02/2023	AWARE SUPER	PAYROLL DEDUCTIONS	1	2,344.54	
INV DEDUCT	14/02/2023	AWARE SUPER	PAYROLL DEDUCTIONS	1	36.70	
INV DEDUCT	14/02/2023	AWARE SUPER	PAYROLL DEDUCTIONS	1	36.70	
INV DEDUCT	14/02/2023	AWARE SUPER	PAYROLL DEDUCTIONS	1	25.00	
INV DEDUCT	14/02/2023	AWARE SUPER	PAYROLL DEDUCTIONS	1	800.00	
INV DEDUCT	14/02/2023	AWARE SUPER	PAYROLL DEDUCTIONS	1	105.79	
INV DEDUCT	14/02/2023	AWARE SUPER	PAYROLL DEDUCTIONS	1	189.76	
INV DEDUCT	14/02/2023	AWARE SUPER	PAYROLL DEDUCTIONS	1	69.28	
INV DEDUCT	14/02/2023	AWARE SUPER	PAYROLL DEDUCTIONS	1	118.25	
DD18910.2	14/02/2023	PLUM SUPERANNUATION FUND	PAYROLL DEDUCTIONS	1		555.01
INV SUPER	14/02/2023	PLUM SUPERANNUATION FUND	SUPERANNUATION CONTRIBUTIONS	1	419.64	
INV DEDUCT	14/02/2023	PLUM SUPERANNUATION FUND	PAYROLL DEDUCTIONS	1	135.37	
DD18910.3	14/02/2023	COLONIAL FIRST STATE SUPERANNUATION	SUPERANNUATION CONTRIBUTIONS	1		503.25
INV SUPER	14/02/2023	COLONIAL FIRST STATE SUPERANNUATION	SUPERANNUATION CONTRIBUTIONS	1	503.25	

**Ordinary Council Meeting Minutes
15 March 2023**

Attachment 13.4.1.1

Date: 01/03/2023
Time: 8:24:14AM

Shire of Northam

USER: Louise Harris
PAGE: 52 10

Cheque /EFT No	Date	Name	Invoice Description	Bank Code	INV Amount	Amount
DD18910.4	14/02/2023	HESTA SUPER FUND	SUPERANNUATION CONTRIBUTIONS	1		450.83
INV SUPER	14/02/2023	HESTA SUPER FUND	SUPERANNUATION CONTRIBUTIONS	1	450.83	
DD18910.5	14/02/2023	QSUPER	PAYROLL DEDUCTIONS	1		619.08
INV SUPER	14/02/2023	QSUPER	SUPERANNUATION CONTRIBUTIONS	1	453.99	
INV DEDUCT	14/02/2023	QSUPER	PAYROLL DEDUCTIONS	1	165.09	
DD18910.6	14/02/2023	MEDIA SUPER	PAYROLL DEDUCTIONS	1		1,272.12
INV SUPER	14/02/2023	MEDIA SUPER	SUPERANNUATION CONTRIBUTIONS	1	932.89	
INV DEDUCT	14/02/2023	MEDIA SUPER	PAYROLL DEDUCTIONS	1	339.23	
DD18910.7	14/02/2023	YKC SUPERFUND	PAYROLL DEDUCTIONS	1		891.34
INV SUPER	14/02/2023	YKC SUPERFUND	SUPERANNUATION CONTRIBUTIONS	1	653.65	
INV DEDUCT	14/02/2023	YKC SUPERFUND	PAYROLL DEDUCTIONS	1	237.69	
DD18910.8	14/02/2023	MACQUARIE SUPER CONSOLIDATOR	SUPERANNUATION CONTRIBUTIONS	1		261.10
INV SUPER	14/02/2023	MACQUARIE SUPER CONSOLIDATOR	SUPERANNUATION CONTRIBUTIONS	1	261.10	
DD18910.9	14/02/2023	CBUS	SUPERANNUATION CONTRIBUTIONS	1		367.50
INV SUPER	14/02/2023	CBUS	SUPERANNUATION CONTRIBUTIONS	1	367.50	
DD18910.10	14/02/2023	MTAA SUPERFUND	SUPERANNUATION CONTRIBUTIONS	1		143.11
INV SUPER	14/02/2023	MTAA SUPERFUND	SUPERANNUATION CONTRIBUTIONS	1	143.11	
DD18910.11	14/02/2023	THE TRUSTEE FOR AMP SUPER FUND	SUPERANNUATION CONTRIBUTIONS	1		216.03
INV SUPER	14/02/2023	THE TRUSTEE FOR AMP SUPER FUND	SUPERANNUATION CONTRIBUTIONS	1	216.03	
DD18910.12	14/02/2023	AUSTRALIAN SUPER PTY LTD	PAYROLL DEDUCTIONS	1		3,993.88
INV SUPER	14/02/2023	AUSTRALIAN SUPER PTY LTD	SUPERANNUATION CONTRIBUTIONS	1	3,581.39	
INV DEDUCT	14/02/2023	AUSTRALIAN SUPER PTY LTD	PAYROLL DEDUCTIONS	1	412.49	

Ordinary Council Meeting Minutes
15 March 2023

Attachment 13.4.1.1

Date: 01/03/2023
Time: 8:24:14AM

Shire of Northam

USER: Louise Harris
PAGE: 53 10

Cheque /EFT No	Date	Name	Invoice Description	Bank Code	INV Amount	Amount
DD18910.13	14/02/2023	ZURICH AUSTRALIA LIMITED	SUPERANNUATION CONTRIBUTIONS	1		656.70
INV DEDUCT	14/02/2023	ZURICH AUSTRALIA LIMITED	PAYROLL DEDUCTIONS	1	175.12	
INV SUPER	14/02/2023	ZURICH AUSTRALIA LIMITED	SUPERANNUATION CONTRIBUTIONS	1	481.58	
DD18910.14	14/02/2023	REST INDUSTRY SUPER	SUPERANNUATION CONTRIBUTIONS	1		1,398.10
INV DEDUCT	14/02/2023	REST INDUSTRY SUPER	PAYROLL DEDUCTIONS	1	290.61	
INV SUPER	14/02/2023	REST INDUSTRY SUPER	SUPERANNUATION CONTRIBUTIONS	1	1,107.49	
DD18910.15	14/02/2023	UNISUPER	SUPERANNUATION CONTRIBUTIONS	1		1,435.07
INV DEDUCT	14/02/2023	UNISUPER	PAYROLL DEDUCTIONS	1	171.23	
INV DEDUCT	14/02/2023	UNISUPER	PAYROLL DEDUCTIONS	1	460.00	
INV SUPER	14/02/2023	UNISUPER	SUPERANNUATION CONTRIBUTIONS	1	803.84	
DD18910.16	14/02/2023	HOSTPLUS SUPER	PAYROLL DEDUCTIONS	1		560.07
INV SUPER	14/02/2023	HOSTPLUS SUPER	SUPERANNUATION CONTRIBUTIONS	1	510.07	
INV DEDUCT	14/02/2023	HOSTPLUS SUPER	PAYROLL DEDUCTIONS	1	50.00	
DD18910.17	14/02/2023	AUSTRALIAN RETIREMENT TRUST	SUPERANNUATION CONTRIBUTIONS	1		597.27
INV SUPER	14/02/2023	AUSTRALIAN RETIREMENT TRUST	SUPERANNUATION CONTRIBUTIONS	1	597.27	
DD18910.18	14/02/2023	AMP LIFE LIMITED	SUPERANNUATION CONTRIBUTIONS	1		227.51
INV SUPER	14/02/2023	AMP LIFE LIMITED	SUPERANNUATION CONTRIBUTIONS	1	227.51	
DD18910.19	14/02/2023	ANZ SMART CHOICE SUPER (ONEPATH MASTERFUND)	SUPERANNUATION CONTRIBUTIONS	1		284.27
INV SUPER	14/02/2023	ANZ SMART CHOICE SUPER (ONEPATH MASTERFUND)	SUPERANNUATION CONTRIBUTIONS	1	284.27	

**Ordinary Council Meeting Minutes
15 March 2023**

Attachment 13.4.1.1

Date: 01/03/2023
Time: 8:24:14AM

Shire of Northam

USER: Louise Harris
PAGE: 54 10

Cheque /EFT No	Date	Name	Invoice Description	Bank Code	INV Amount	Amount
-------------------	------	------	---------------------	--------------	---------------	--------

REPORT TOTALS

Bank Code	Bank Name	TOTAL
1	MUNI FUND	1,868,020.07
TOTAL		1,868,020.07

Payment dates 1st February 2023 – 28th February 2023

- Municipal Fund payment cheque numbers 35556 to 35560 Total \$44,706.25.

Electronic Funds Transfer

- Municipal Fund EFT46316 to EFT46589 Total \$1,775,425.15.
- Direct Debits Total \$47,888.67.

All have been made in accordance with delegated authority reference number (M/F/F/Regs LGA 1995 S5.42).

Month	Cheques 2022/2023	EFT Payments 2022/2023	Direct Debits 2022/2023	Payroll 2022/2023	Total Payments 2022/2023
July	\$ 35,158.28	\$ 1,922,165.42	\$ 92,241.22	\$ 450,983.16	\$ 2,500,548.08
August	\$ 49,755.57	\$ 1,862,348.43	\$ 96,210.39	\$ 456,701.51	\$ 2,465,015.90
September	\$ 20,008.62	\$ 1,849,919.23	\$ 100,596.70	\$ 719,541.42	\$ 2,690,065.97
October	\$ 27,379.34	\$ 1,879,280.09	\$ 99,709.19	\$ 493,924.90	\$ 2,500,293.52
November	\$ 28,185.68	\$ 2,153,587.29	\$ 97,145.92	\$ 526,791.12	\$ 2,805,710.01
December	\$ 59,627.70	\$ 2,127,298.89	\$ 105,047.33	\$ 519,667.53	\$ 2,811,641.45
January	\$ 72,199.65	\$ 1,402,773.56	\$ 99,993.29	\$ 517,940.53	\$ 2,092,907.03
February	\$ 44,706.25	\$ 1,775,425.15	\$ 47,888.67	\$ 532,957.08	\$ 2,400,977.15
March					\$ -
April					\$ -
May					\$ -
June					\$ -
Total	\$ 337,021.09	\$ 14,972,798.06	\$ 738,832.71	\$ 4,218,507.25	\$ 20,267,159.11

The following table presents all payments made for the month from Council credit cards paid by direct debit DD18886.1 - \$2,089.32

Summary Credit Card Payments	\$	Total
CEO		
DOME NORTHAM - COFFEE WITH MILLS RECRUITMENT	9.40	
Q NGUYEN & T NGUYEN - MORNING TEA FOR STAFF	42.00	
AMPOL CANNINGTON - FUEL FOR CEO VEHICLE	90.39	
COLES EXPRESS - MILK FOR ADMIN OFFICE	11.00	
THE ISLAND TRUST BAKERSHILL - MEETING REFRESHMENT	8.70	

DOMESTIC NORTHAM - COFFEE WITH SHIRE PRESIDENT	4.70	
WANNEWSDTI - WA NEWS ONLINE SUBSCRIPTION	84.00	
		\$ 250.19
Executive Manager of Community Services		
AUSPIRE - NOMINEE APPRECIATION CERTIFICATES	16.24	
DEPT OF MINES, INDUSTRY REGULATION & SAFETY - NORTHAM AQUATIC FACILITY DANGEROUS GOODS LICENSE RENEW	287.00	
JB HI-FI - MOVIE FOR THE EVENT ON AUS DAY EVENING	19.98	
FACEBOOK - BOOST FOR JOB ADVERT	110.00	
FACEBOOK - BOOST FOR JOB ADVERT	110.00	
		\$ 543.22
Executive Manager of Corporate Services		
RED ROOSTER NORTHAM - REFRESHMENT FOR COUNCIL MEETING	224.00	
DEPARTMENT OF TRANSPORT - PLATE SWAP FROM N10996 TO 1HSZ958	30.50	
AMAYSIM MOBILE PTY LTD - LIBRARY LIFT PHONE DATA	10.00	
ADOBE ID CREATIVE CLOUD - MONTHLY FEES	225.96	
FOREIGN TRANSACTION FEE	6.50	
		\$ 496.96
Executive Manager of Development Services		
DEPT MINES INDUSTRY REGULATION & SAFETY - ANNUAL DGS LICENCE FOR WWTP - DGS012614	287.00	
DEPARTMENT OF TRANSPORT - LICENSING N10996 MITSUBISHI TRITON	245.50	
		\$ 532.50
Executive Manager of Engineering Services		
SUBWAY NORTHAM - CATERING FOR PRE-SEASON TRAINING	86.45	
LUCYS TEAROOMS - INCIDENT CATERING DFES	180.00	
		\$ 266.45
Total Credit Card Expenditure		\$ 2,089.32

CERTIFICATION OF THE PRESIDENT

I hereby certify that this schedule of account covering vouchers and electronic fund transfer payments as per above and totalling \$2,400,977.15 was submitted to the Ordinary Meeting of Council on Wednesday, 15 March 2023.

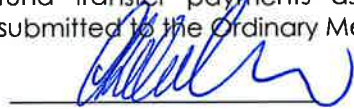

CERTIFICATION OF THE PRESIDENT

CERTIFICATE OF THE CHIEF EXECUTIVE OFFICER

This schedule of accounts paid covering vouchers \$2,400,977.15 was submitted to each member of the Council on Wednesday, 15 March 2023, has been checked and is fully supported by vouchers and invoices which are submitted herewith, and which have been duly certified as to the receipt of goods and the rendition of services and as to prices, computations and casting and the amounts shown are due for payment.

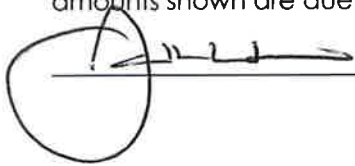

CHIEF EXECUTIVE OFFICER

13.4.2 Financial Statements for the period 1 February 2023 to 28 February 2023

File Reference:	2.1.3.4
Reporting Officer:	Kudzai Matanga (Senior Accountant)
Responsible Officer:	Colin Young (Executive Manager Corporate Services)
Officer Declaration of Interest:	Nil
Voting Requirement:	Simple Majority
Press release to be issued:	No

BRIEF

For Council to receive the Financial Statement for the period ending 28 February 2023.

ATTACHMENTS

1. Statement of Financial Activity - February 2023 [**13.4.2.1** - 15 pages]

A. BACKGROUND / DETAILS

The reporting of monthly financial information is a requirement under section 6.4 of the Local Government Act 1995, and Regulation 34 of the Local Government (Financial Management) Regulations.

The Statement of Financial Activity for the period ending 28 February 2023 is included as Attachment 1 to this agenda and includes the following reports:

- Statement of Financial Activity
- Operating Statements
- Balance Sheet
- Acquisition of Assets
- Disposal of Assets
- Information on Borrowings
- Reserves
- Net Current Assets
- Cash Position
- Rating Information
- Cash Flow Information

The report includes a summary of the financial position along with comments relating to the statements. If Councilors wish to discuss the report contents or

any other matters relating to this matter, please contact Council finance staff prior to the meeting.

Notes to the Financial Statements (items in bold represent new notes)

Operating Revenue

1. Operating grants down by 36% due timing. Of the 1,4million WANDRRA funding only \$ 72,724 has been received to date. All requested submissions have been made and we await feedback.
2. Interest earnings are under budget by 32% due to the timing of interest being brought to account on Shire investments.

Operating Expenditure

3. Other expenditure is over budget by \$213,357 mainly due to public works overheads allocations that are under budget due to timing.
4. Non-Operating grants are over budget by 66% mainly due to timing. Received \$ 447,000 above yield to date budget for blackspot funding and \$676,255 above yield to date budget from Main Roads commodity route funding. We also received \$ 385,500 to date for bridges from FAGS. Of the \$ 385,500 \$ 114,00 will be channelled towards Eadine bridge and the rest will pay main roads for the replacement of the old York Road bridge.

Capital Expenditure

5. There was no capital budget for the year 22/23 for Southern brook road however the expenditure on the road construction came through in the Month of August. The capital budget amendment was approved in the December council meeting, and this will be updated when the 22/23 amended budget is uploaded.

B. CONSIDERATIONS

B.1 Strategic Community / Corporate Business Plan

Performance Area: Performance. Outcome 12: Excellence in organisational performance and customer service.

Objective 12.1: Maintain a high standard of corporate governance and financial management.

Priority Action: Nil.

B.2 Financial / Resource Implications

The Financial Statements have been prepared in accordance with Council's 22/23 Budget.

B.3 Legislative Compliance

Section 6.4 and 6.26(2)(g) of the Local Government Act.
Local Government (Financial Management) Regulations 1996.

B.4 Policy Implications

Nil.

B.5 Stakeholder Engagement / Consultation

N/A

B.6 Risk Implications

Risk Category	Description	Rating (consequence x likelihood)	Mitigation Action
Financial	Figures not reflecting the true financial situation	Rare (2) x Medium (3) = Low (3)	There are processes in place to show compliance with relevant legislation
Health & Safety	N/A	N/A	N/A
Reputation	N/A	N/A	N/A
Service Interruption	N/A	N/A	N/A
Compliance	Report not being accepted by Council	Rare (2) x Medium (3) = Low (3)	There are processes in place to ensure compliance with relevant legislation
Property	N/A	N/A	N/A
Environment	N/A	N/A	N/A

B.7 Natural Environment Considerations

Nil.

C. OFFICER'S COMMENT

Nil.

RECOMMENDATION / COUNCIL DECISION

Minute No: C.4695

Moved: Cr D A Hughes

Seconded: Cr M I Girak

That Council receives the Financial Statements, prepared in accordance with the Local Government (Financial Management) Regulations, for the period ending 28 February 2023.

CARRIED 8/0



Shire of Northam

SHIRE OF NORTHAM

MONTHLY STATEMENT OF FINANCIAL ACTIVITY

FOR THE PERIOD ENDING 28 FEBRUARY 2023

TABLE OF CONTENTS

	Page
Statement of Financial Activity	2 to 4
Notes to and forming part of the statement	
Acquisition of Assets	5 to 8
Disposal of Assets	9
Information on Borrowings	10
Reserves	11
Net Current Assets	12
Rating Information	13
Cash Flow Information	14
Investment Schedule	15



SHIRE OF NORTHAM
STATEMENT OF FINANCIAL ACTIVITY
FOR THE PERIOD ENDING 28 FEBRUARY 2023

	NOTE	2022/23 Budget	Ytd Budget	2022/23 Ytd Actual	Variances Actuals to Budget	Variances Actuals to Budget
OPERATING REVENUE						
Rates		11,360,033	11,340,033	11,341,164	1,131	0%
Operating Grants Subsidies and Contributions	1	6,172,224	3,758,671	2,410,166	(1,348,505)	-36%
Fees and Charges		4,416,789	3,365,889	3,531,718	165,829	5%
Interest Earnings	2	325,000	214,990	146,108	(68,882)	-32%
Other Revenue		1,079,015	735,963	610,390	(125,573)	-17%
TOTAL OPERATING REVENUE		23,353,061	19,415,546	18,039,546	(1,376,000)	-7%
OPERATING EXPENSES						
Employee Costs		(9,681,211)	(6,729,074)	(6,370,295)	358,779	-5%
Materials and Contracts		(8,702,468)	(5,028,790)	(4,625,662)	403,128	-8%
Utility Charges		(1,167,337)	(730,532)	(744,912)	(14,380)	2%
Depreciation of Non Current Assets		(5,080,238)	(3,386,712)	(3,426,631)	(39,919)	1%
Interest Expenses		(253,065)	(140,860)	(134,125)	6,735	-5%
Insurance Expenses		(556,858)	(553,524)	(556,220)	(2,696)	0%
Other Expenditure	3	(225,549)	(158,954)	(372,311)	(213,357)	134%
TOTAL OPERATING EXPENSE		(25,666,726)	(16,728,446)	(16,230,156)	498,290	-3%
Non Operating Grants Subsidies and Contributions	4	5,246,091	2,031,492	3,380,096	1,348,604	66%
Profit on Asset Disposals		54,645	51,973	0	(51,973)	-100%
Loss on Asset Disposals		(124,463)	(124,463)	0	124,463	-100%
RESULTING FROM OPERATIONS		2,862,608	4,646,102	5,189,486	543,384	12%
Removal of Non-Cash Items						
(Profit)/Loss on Asset Disposals		69,818	0	0	0	
Depreciation on Assets		5,080,238	3,386,712	3,426,631	39,919	
Non Operating Items						
Purchase Land and Buildings		(3,185,983)	(595,576)	(579,054)	16,522	
Purchase Plant and Equipment		(1,314,956)	(1,199,956)	0	1,199,956	
Purchase Furniture and Equipment		0	0	0	0	
Purchase Bush Fire Equipment		0	0	0	0	
Purchase Infrastructure Assets - Roads		(7,886,066)	(4,975,713)	(3,044,633)	1,931,080	
Purchase Infrastructure Assets - Bridges		0	0	0	0	
Purchase Infrastructure Assets - Footpaths		(259,628)	(234,190)	(1,684)	232,506	
Purchase Infrastructure Assets - Drainage		(2,032,117)	(1,721,703)	(55,648)	1,666,055	
Purchase Infrastructure Assets - Parks & Ovals		(2,218,734)	(1,150,562)	(91,212)	1,059,350	
Purchase Infrastructure Assets - Airfields		(164,500)	(109,664)	0	109,664	
Purchase Infrastructure Assets - Streetscape		(21,000)	(14,000)	(7,838)	6,162	
Purchase Infrastructure Assets - Other		(238,150)	(190,950)	(136,331)	54,619	
Proceeds from Disposal of Assets		379,000	0	0	0	
Repayment of Debentures		(407,957)	(281,549)	(281,549)	0	
Proceeds from New Debentures		2,700,000	0	0	0	
Self-Supporting Loan Principal Income		27,518	10,674	10,674	0	
Transfers to Restricted Assets (Reserves)		(340,054)	0	0	0	
Transfers from Restricted Asset (Reserves)		2,859,420	2,849,512	2,859,420	9,908	
ADD Net Current Assets July 1 B/Fwd		4,090,543	4,090,543	4,090,543	0	
LESS Net Current Assets Year to Date			4,509,680	10,731,161	6,221,481	
Surplus/Deficit		0	0	647,644	647,644	

This statement is to be read in conjunction with the accompanying notes.



**SHIRE OF NORTHAM
STATEMENT OF COMPREHENSIVE INCOME BY PROGRAM
FOR THE PERIOD ENDING 28 FEBRUARY 2023**

	NOTE			Variences	Variences
<u>Operating</u>	22/23	Ytd	22/23	Actuals to	Actuals to
	Budget	Budget	Ytd Actual	Budget	Budget
	\$	\$	\$	\$	%
Revenues					
Governance	30,070	23,448	69,270	45,822	195.42%
General Purpose Funding Other	12,712,487	12,325,842	12,304,966	(20,876)	(0.17%)
Law, Order, Public Safety	2,132,072	844,578	735,259	(109,319)	(12.94%)
Health	61,000	48,764	29,539	(19,225)	(39.43%)
Education and Welfare	1,200,818	897,896	994,099	96,203	10.71%
Housing	62,277	41,512	31,032	(10,480)	(25.25%)
Community Amenities	3,034,721	2,477,258	2,448,578	(28,680)	(1.16%)
Recreation and Culture	1,773,633	581,479	467,889	(113,590)	(19.53%)
Transport	6,722,283	3,595,187	3,651,302	56,115	1.56%
Economic Services	740,236	540,263	532,851	(7,412)	(1.37%)
Other Property and Services	184,200	122,784	154,858	32,074	26.12%
Total Operating Revenue	28,653,797	21,499,011	21,419,643	(79,368)	(0.37%)
Expenses					
Governance	(2,409,672)	(1,074,357)	(861,483)	212,874	19.81%
General Purpose Funding	(321,096)	(200,523)	(147,271)	53,252	26.56%
Law, Order, Public Safety	(2,481,548)	(1,674,977)	(1,370,321)	304,656	18.19%
Health	(390,849)	(267,679)	(281,309)	(13,630)	(5.09%)
Education and Welfare	(1,371,049)	(945,726)	(821,541)	124,185	13.13%
Housing	(72,696)	(48,379)	(43,458)	4,921	10.17%
Community Amenities	(4,049,132)	(2,492,572)	(2,590,876)	(98,304)	(3.94%)
Recreation & Culture	(5,337,630)	(3,684,222)	(3,407,161)	277,061	7.52%
Transport	(6,587,228)	(4,503,365)	(4,199,086)	304,279	6.76%
Economic Services	(2,719,820)	(1,883,198)	(1,777,309)	105,889	5.62%
Other Property and Services	(50,469)	(77,911)	(730,341)	(652,430)	(837.40%)
Total Operating Expenses	(25,791,189)	(16,852,909)	(16,230,156)	622,753	3.70%
NET RESULT	2,862,608	4,646,102	5,189,486	543,384	3%

This statement is to be read in conjunction with the accompanying notes.



SHIRE OF NORTHAM

NOTES TO AND FORMING PART OF THE STATEMENT OF FINANCIAL ACTIVITY

FOR THE PERIOD ENDING 28 FEBRUARY 2023

2. BALANCE SHEET

	22/23 YTD Actual \$	21/22 Actual \$
CURRENT ASSETS		
Cash Assets	11,200,766	9,938,795
Receivables	4,260,526	3,120,591
Inventories & Other Assets	0	27,519
TOTAL CURRENT ASSETS	15,461,292	13,086,905
NON-CURRENT ASSETS		
Receivables	608,173	608,173
Inventories	0	0
Land and Buildings	58,516,010	57,470,183
Property, Plant and Equipment	6,212,387	7,447,579
Infrastructure	171,684,424	170,883,012
Financial & Other Assets	282,557	233,411
TOTAL NON-CURRENT ASSETS	237,303,551	236,642,358
TOTAL ASSETS	252,764,843	249,729,263
CURRENT LIABILITIES		
Payables	1,536,041	3,709,448
Interest-bearing Liabilities	98,491	368,947
Provisions	1,312,900	1,312,900
TOTAL CURRENT LIABILITIES	2,947,432	5,391,295
NON-CURRENT LIABILITIES		
Interest-bearing Liabilities	5,370,931	5,370,931
Provisions	151,151	151,151
Payables	159,546	159,546
TOTAL NON-CURRENT LIABILITIES	5,681,628	5,681,628
TOTAL LIABILITIES	8,629,060	11,072,923
NET ASSETS	244,135,634	238,656,340
EQUITY		
Retained Surplus	117,944,708	112,254,836
Reserves - Cash Backed	5,567,109	5,868,771
Reserves - Asset Revaluation	120,623,817	120,532,733
TOTAL EQUITY	244,135,634	238,656,340



SHIRE OF NORTHAM

NOTES TO AND FORMING PART OF THE STATEMENT OF FINANCIAL ACTIVITY

FOR THE PERIOD ENDING 28 FEBRUARY 2023

3. ACQUISITION OF ASSETS	22/23 Revised Budget \$	22/23 Ytd Actual \$
The following assets have been acquired during the period under review:		
By Program		
Governance		
Admin Building Minor Works	Note 6,500	0
Law, Order & Public Safety		
CESM Vehicle PN1711 C/fwd	75,000	0
CBFO Vehicle	40,000	0
Inkpen Extension C/fwd	140,000	0
New Single Fireshed Wundowie C/fwd	53,510	0
Wundowie Fireshed	443,000	0
Fire Other Infrastructure	54,655	0
Building Animal Control Stock Yards C/fwd	18,000	18,734
Upgrade Stock Pound	38,500	2,890
Driveway and air conditioner Pound	8,700	4,570
SES Shed Extension - Bays & Garrison Fencing C/fwd	119,597	65,017
Education & Welfare		
Replacement Vehicles (2 Hyundai's)	67,000	0
Killara Solar Lights	3,800	956
Daycare Building Upgrade	12,500	1,340
Upgrade Kitchen Memorial Hall cfwd	61,800	61,699
Structural Repairs Memorial Hall cfwd	20,000	3,000
CCTV upgrade Memorial Hall	15,000	0
Memorial Hall Gutters	1,500	0
Housing		
Restoration Pool House	110,000	0
Community Amenities		
Old Quarry Drainage cfwd	28,400	7,655
Transfer Station Tip Shop cfwd	151,050	121,216
Area Drainage Upgrade/ Renewal	128,669	0
CBD Improvements	14,000	7,838
Community Group RAC Discovering Rail Line	7,000	0
Leach Drain Hoopers Park Toilets	6,500	6,145

SHIRE OF NORTHAM

NOTES TO AND FORMING PART OF THE STATEMENT OF FINANCIAL ACTIVITY

FOR THE PERIOD ENDING 28 FEBRUARY 2023

3. ACQUISITION OF ASSETS (Continued)	Note	22/23 Revised Budget \$	22/23 Ytd Actual \$
By Program (Continued)			
Recreation & Culture			
Update LED Lights Clackline Hall		4,500	4,250
Sand and Seal floor Wundowie Hall		13,500	0
Upgrade Grass Valley Hall Kitchen		14,000	3,135
Fence Ceiling repairs Northam Hall		10,800	6,390
Change Unisex Toilet Locks and Door Vents NAF		4,500	0
Wundowie Pool Bowl Repainting cfwd		10,000	0
Repaint and Remove Rust of Fence NAF		1,500	0
Install Garrison Fencing Northam Rec Centre		18,000	18,290
Install Handrail Entrance Northam Rec Centre		5,000	0
Convert Existing Fire Doors Rec Centre		5,000	4,364
Bert Hawke Pavillion Including kitchen cfwd		1,500	1,500
Lighting to Ramp Northam rec Centre		1,800	1,500
External Lights Northam Rec Centre		1,800	1,600
Repaint Benches Entry Posts Northam Rec Centre		3,500	1,525
Replace Court Lights LED, Northam Rec Centre		25,000	0
Upgrade CCTV Northam Rec Centre		19,000	0
POS Playground Improvements		0	89
Landscaping/demolition Old Pool site cfwd		459,800	2,240
Improvements Dr Dunlop Park cfwd		27,000	740
Council Plan Action 3.2.7 Infrastructure B/Hill Precinct		30,000	0
Recreation Precinct Upgrades		50,000	32,113
Council Plan Action 3.2.8 Bert Hawke Oval/ Hockey			
Ground Improvements		50,000	0
RV Friendly Bakers Hill cfwd		95,000	0
Overnight Caravan Stay Dump point cfwd		13,500	0
Council Plan Action 3.2.11 Henry Street Oval			
Improvements		75,000	0
Council Plan Action 3.2.12 Portable Grandstands		80,000	0
Shade Structures Bakers Hill cfwd		50,000	50,540
Council Plan Action 8.3.4 Clackline Playground		40,000	0
Track Enhancements Northam Motor Festival		475,000	0
Northam BMX Redevelopment		223,734	0
Council Plan Action 9.1.8 Electric Charging Stations			
(Carpark)		220,000	5,490
Council Plan Action 9.2.8 Improved Tracks & Trails		50,000	0
Council Plan Action 10.4.3 Overnight RV, Northam			
& B/Hill		245,000	0
Wundowie Oval Scheme Water Conversion		34,700	0
Upgrade CCTV Library		13,500	0
Old Girls School, Install Bird Mesh to Eaves		5,100	4,500
AVVVA - Roof Repairs		14,000	10,872
Old Railway Station platform C/fwd		120,000	1,984
Old Railway Station extra platform lights C/fwd		2,500	0

SHIRE OF NORTHAM
NOTES TO AND FORMING PART OF THE STATEMENT OF FINANCIAL ACTIVITY
FOR THE PERIOD ENDING 28 FEBRUARY 2023

3 ACQUISITION OF ASSETS (Continued)	Note	22/23 Revised Budget	22/23 Ytd Actual
Transport			
Northam Depot Redesign cfwd		1,608,521	331,047
Mudalla Way 0- 100		29,150	0
Chidlow Street West SLK 2390-2690		77,110	0
East Street SLK 410-510		27,159	0
Peel Terrace SLK 150-210		26,658	0
Beavis Place SLK 0-90		11,946	1,684
Forrest Street SLK 730-980		62,167	0
Wellington Street SLK 190-270		25,438	0
Drainage - Rural Upgrade		234,448	19,683
Drainage - Rural Renewal		234,000	27,969
Drainage AGRN 962		1,300,000	7,996
Jennapullin Road 1.3-2.05		94,000	59,173
Jennapullin Road 2.58-3.19		222,220	300
Southern Brook Road Slk 19.33-20.36		201,800	79,624
Jennapullin Road 5.05-6.19		378,276	364
Grass Valley South Road Slk 0-1.1		280,000	0
Dring Street Slk 0.16-0.18		1,400	0
Croke Avenue 0-0.66		67,767	67,040
Leeder Road Slk 0-1.92		140,800	0
Linley Valley Road Slk 0-0.81		335,500	0
Robinson Road SLK 0.02-0.75		282,000	279,796
Wellington Street Slk 2.46-2.72		220,000	221,281
Capitalised Maintenance		37,700	0
Leschenaultia Road 0-350		32,008	33,051
Harvey Road 0-470		62,200	62,201
Beavis Place 0.0-1.03		90,000	0
Forrest Street 0.0-1.03		390,000	0
Southern Brook Road 16330-17300	5	0	196,877
Centrelink Bay		22,250	0
Charles Street 510-1070		3,450	0
Kurringal Road Slk 0-550 cfwd		93,100	95,890
Springfield Road Slk 0-120 cfwd		7,950	3,933
Henry Street Slk 0 - 190		143,686	1,980
Parker Street Slk 0-0.65		46,000	0
Cox Street Slk 0-0.23		5,524	-10,571
Forward Street Slk 0-0.22		10,600	0
Clarke Street 0-1		132,480	122,987
Mokine Road 0.0-1.92		209,000	0
Fitzgerald Street 2-2.74		307,400	0
BS Spencers Brook Road SLK 0-23.63		1,413,692	1,386,656
BS Forrest Street Slk 0.21-1.03		203,640	187,662
BS Mitchell Avenue Slk 0.21-3.4		38,000	5,257
Grass Valley North Road 9.80-10.52		322,510	124,943
DFRRA AGRN 962		1,381,637	0
Tamma Road		150,000	106,535
Kerb Renewal		109,238	0
Culvert Renewal		450,238	19,654
N.002 volvo G930 2014 Grader		382,000	0
John Deere Tractor 2015 (N11063)		77,818	0
Traffic Light Bartco 2 OF 2 1TRA501		14,750	0
Traffic Light Bartco 2 OF 2 1TRA502		14,750	0
John Deere Z-track Ride on Mower-Z997		42,264	0
Hino Dual Cab Truck 300 Series 921 Crew Diesel (N.003)		60,000	0
Mitsubishi Triton Single Cab Ute N11469 Manual		34,000	0
Nissan Navara Ute N11164 T/TOP 2015		34,000	0
Holden Colorado Crew Cab 4X4 LT2 Auto 2.8L		45,000	0
PN0001 Tandem Trailer for Dynapac Roller		6,000	0
Tandem Trailer cfwd		15,250	0
PN1009A 2 Way Pig Trailer		82,690	0
PN1515 Mitsubishi 2 Way Tipper Truck		241,435	0
Variable Message Board - Insurance Claim		24,499	0
Float Trailer		58,500	0

SHIRE OF NORTHAM

NOTES TO AND FORMING PART OF THE STATEMENT OF FINANCIAL ACTIVITY

FOR THE PERIOD ENDING 28 FEBRUARY 2023

3. ACQUISITION OF ASSETS (Continued)	Note	22/23 Revised Budget \$	22/23 Ytd Actual \$
<u>By Program (Continued)</u>			
Transport			
Lot Development		14,500	0
New toilet block		150,000	0
Economic Services			
Replace Gutters Old Post Office		16,800	16,800
Replace External Lights, LED		5,500	3,454
Old Northam Fire Station, Wall Panelling		3,400	0
Old Northam Fire Station Kitchen		5,000	0
Old Northam Fire Station, Drainage and Motar Repairs		30,000	0
Rivers Edge Café, New Canvas and Painting		11,400	10,552
Water Use Study		93,000	0
Water Study Wundowie		17,000	0
Bakers Hill Water Project easement cfwd		25,000	0
BKB Building Phase 2 Interpretive incl fire pit		156,000	400
		<u>17,321,134</u>	<u>3,916,400</u>

SHIRE OF NORTHAM

NOTES TO AND FORMING PART OF THE STATEMENT OF FINANCIAL ACTIVITY

FOR THE PERIOD ENDING 28 FEBRUARY 2023

3. ACQUISITION OF ASSETS (Continued)	Note	22/23 Revised Budget \$	22/23 Ytd Actual \$
<u>By Class</u>			
Land Held for Resale		0	0
Land and Buildings		3,185,983	579,054
Plant and Equipment		1,314,956	0
Furniture and Equipment		0	0
Bush Fire Equipment		0	0
Playground Equipment		0	0
Infrastructure Assets - Roads		7,886,066	3,044,633
Infrastructure Assets - Footpaths		259,628	1,684
Infrastructure Assets - Bridges & Culverts		0	0
Infrastructure Assets - Drainage		2,032,117	55,648
Infrastructure Assets - Parks & Ovals		2,218,734	91,212
Infrastructure Assets - Airfields		164,500	0
Infrastructure Assets - Streetscape		21,000	7,838
Infrastructure Assets - Other		238,150	136,331
		<u>17,321,134</u>	<u>3,916,400</u>



SHIRE OF NORTHAM

NOTES TO AND FORMING PART OF THE STATEMENT OF FINANCIAL ACTIVITY
FOR THE PERIOD ENDING 28 FEBRUARY 2023

4. DISPOSALS OF ASSETS

The following assets have been disposed of during the period under review:

By Program	Written Down Value		Sale Proceeds		Profit(Loss)	
	22/23 Budget \$	Ytd Actual \$	22/23 Budget \$	Ytd Actual \$	22/23 Budget \$	Ytd Actual \$
Law Order & Public Safety						0
CESM Vehicle PN1711	18,500	0	24,500	0	6,000	0
Toyota Hilux Duel Cab Ute CBFBO	10,000	0	12,000	0	2,000	0
Welfare						0
Hyundai VF2 I40 2.O Auto Wagon	15,000	0	12,000	0	(3,000)	0
Transport						0
N.002 volvo G930 2014 Grader	139,845	0	80,000	0	(59,845)	0
John Deere Tractor 2015 (N11063)	27,342	0	40,000	0	12,658	0
Traffic Light Bartoo 2 OF 2 1TRA501	6,771	0	1,000	0	(5,771)	0
Traffic Light Bartoo 2 OF 2 1TRA502	6,771	0	1,000	0	(5,771)	0
John Deere Z-track Ride on Mower-Z997	10,960	0	1,500	0	(9,460)	0
EWP -Haulotte HTA 13P BILJAX Trailer Mount 2016	20,210	0	10,000	0	(10,210)	0
Hino Dual Cab Truck 300 Series 921 Crew Diesel (N.003)	39,617	0	50,000	0	10,383	0
Instant Weighing Compuload 4000 Digital Scales	3,000	0	3,000	0	0	0
Mitsubishi Triton Single Cab Ute N11469 Manual	10,000	0	15,000	0	5,000	0
Nissan Navara Ute N11164 T/TOP 2015	10,000	0	12,000	0	2,000	0
Holden Colorado Crew Cab 4X4 LT2 Auto 2.8L	28,233	0	23,000	0	(5,233)	0
PN590 Trailer - TM C/fwd	5,500	0	1,000	0	(4,500)	0
PN1009A N5477 two way pig trailer C/fwd	28,673	0	8,000	0	(20,673)	0
PN1515 Mitsi 2way Tip Truck C/fwd	68,396	0	85,000	0	16,604	0
	448,818	0	379,000	0	(69,818)	0

By Class	Written Down Value		Sale Proceeds		Profit(Loss)	
	22/23 Budget \$	Ytd Actual \$	22/23 Budget \$	Ytd Actual \$	22/23 Budget \$	Ytd Actual \$
Plant & Equipment						0
CESM Vehicle PN1711	18,500	0	24,500	0	6,000	0
Toyota Hilux Duel Cab Ute CBFBO	10,000	0	12,000	0	2,000	0
Hyundai VF2 I40 2.O Auto Wagon	15,000	0	12,000	0	(3,000)	0
N.002 volvo G930 2014 Grader	139,845	0	80,000	0	(59,845)	0
John Deere Tractor 2015 (N11063)	27,342	0	40,000	0	12,658	0
Traffic Light Bartoo 2 OF 2 1TRA501	6,771	0	1,000	0	(5,771)	0
Traffic Light Bartoo 2 OF 2 1TRA502	6,771	0	1,000	0	(5,771)	0
John Deere Z-track Ride on Mower-Z997	10,960	0	1,500	0	(9,460)	0
EWP -Haulotte HTA 13P BILJAX Trailer Mount 2016	20,210	0	10,000	0	(10,210)	0
Hino Dual Cab Truck 300 Series 921 Crew Diesel (N.003)	39,617	0	50,000	0	10,383	0
Instant Weighing Compuload 4000 Digital Scales	3,000	0	3,000	0	0	0
Mitsubishi Triton Single Cab Ute N11469	10,000	0	15,000	0	5,000	0
Nissan Navara Ute N11164 T/TOP 2015	10,000	0	12,000	0	2,000	0
Holden Colorado Crew Cab 4X4 LT2 Auto 2.8L	28,233	0	23,000	0	(5,233)	0
PN590 Trailer - TM C/fwd	5,500	0	1,000	0	(4,500)	0
PN1009A N5477 two way pig trailer C/fwd	28,673	0	8,000	0	(20,673)	0
PN1515 Mitsi 2way Tip Truck C/fwd	68,396	0	85,000	0	16,604	0
	448,818	0	379,000	0	(69,818)	0

Summary

Profit on Asset Disposals
Loss on Asset Disposals

22/23 Budget \$	Ytd Actual \$
54,645	0
(124,463)	0
(69,818)	0



SHIRE OF NORTHAM

NOTES TO AND FORMING PART OF THE STATEMENT OF FINANCIAL ACTIVITY

FOR THE PERIOD ENDING 28 FEBRUARY 2023

5 INFORMATION ON BORROWINGS

(a) Debenture Repayments

Particulars	Principal 1-Jul-22	New Loans		Principal Repayments		Principal Outstanding		Interest Repayments	
		22/23 Budget \$	22/23 Ytd Actual \$	22/23 Budget \$	22/23 Ytd Actual \$	22/23 Budget \$	22/23 Ytd Actual \$	22/23 Budget \$	22/23 Ytd Actual \$
Recreation & Culture									
Loan 219A - Northam Bowling Club **	3.18%	102,413	0	21,518	10,674	80,895	91,739	3,877	2,546
Loan 224 - Recreation Facilities	6.48%	666,660	0	56,625	27,861	610,035	638,799	46,964	31,214
Loan 227 - Youth Space	2.26%	361,611	0	48,242	23,986	313,369	337,625	10,432	6,891
Loan 228 - Swimming Pool	1.88%	4,025,187	0	196,233	196,233	3,828,954	3,828,954	102,932	67,935
COVID-19 Response Depot	4.90%	0	1,700,000	39,010	0	1,660,990	0	50,436	0
COVID-19 Response Initiative	4.70%	0	1,000,000	0	0	1,000,000	0	0	0
Economic Services									
Loan 225 - Victoria Oval Purchase	6.48%	545,449	0	46,329	22,795	499,120	522,654	38,424	25,539
		5,701,320	2,700,000	407,957	281,549	7,993,363	5,419,771	253,065	134,125

Note: ** indicates self - supporting loans

All other debenture repayments are to be financed by general purpose revenue.



SHIRE OF NORTHAM

NOTES TO AND FORMING PART OF THE STATEMENT OF FINANCIAL ACTIVITY

FOR THE PERIOD ENDING 28 FEBRUARY 2023

	22/23 Budget				Total	22/23 Ytd Actual				Total
	Opening Bal	Interest	Tfr To Reserve	Tfr From Reserve		Opening Bal	Interest	Tfr To Reserve	Tfr From Reserve	
6. RESERVES - CASH BACKED										
Employee Liability Reserve	825,439	18,714	-	(47,278)	796,875	825,439			(47,278)	778,161
Office Equipment Reserve	100,000	2,268	-		102,268	100,000				100,000
Plant & Equipment Reserve	119,215	2,702	-	-	121,917	119,215				119,215
Road & Bridgeworks Reserve	200,000	4,534	-		204,534	200,000				200,000
Refuse Site Reserve	327,443	7,360	161,000	-	495,803	327,443				327,443
Speedway Reserve	150,579	3,414	-		153,993	150,579				150,579
Community Bus Replacement Reserve	100,100	2,269	-		102,369	100,100				100,100
Septage Pond Reserve	282,908	6,414	21,794		311,116	282,908				282,908
Killara Reserve	444,889	10,086	-	(54,384)	400,591	444,889			(54,384)	390,505
Recreation and Community Facilities Reserve	143,009	3,242	82,260	(200,000)	28,511	143,009				143,009
Council Buildings & Amenities Reserve	278,478	6,313	-		284,791	278,478			(200,000)	78,478
Parking Facilities Construction Reserve	100,000	2,267	-		102,267	100,000				100,000
Reticulation Scheme Reserve	236,299	5,357	-		241,656	236,299				236,299
Revaluation Reserve	2,654	60	-		2,714	2,654				2,654
Unspent Grants Reserve	2,557,758	-	-	(2,557,758)	-	2,557,758			(2,557,758)	-
Total Cash Backed Reserves	5,868,771	75,000	265,054	(2,859,420)	3,349,405	5,868,771	-	-	(2,859,420)	3,009,351
Total Interest & Transfers				340,054						

All of the above reserve accounts are to be supported by money held in financial institutions.



SHIRE OF NORTHAM

NOTES TO AND FORMING PART OF THE STATEMENT OF FINANCIAL ACTIVITY

FOR THE PERIOD ENDING 28 FEBRUARY 2023

	22/23 Budget	22/23 Ytd Actual	21/22 Financial Report
	\$	\$	\$
7. NET CURRENT ASSETS			
Composition of Estimated Net Current Asset Position			
CURRENT ASSETS			
Cash - Unrestricted	200,000	8,191,415	4,070,024
Cash - Restricted Reserves	3,349,405	3,009,351	5,868,771
Self Supporting Loan	21,518	13,844	27,519
Receivables	2,778,816	586,321	536,337
Rates - Current	0	3,618,376	2,433,612
Pensioners Rates Rebate	0	25,819	0
Provision for Doubtful Debts	0	(111,092)	(111,092)
GST Receivables	0	127,259	261,735
Inventories	1,000	0	0
	<u>6,350,739</u>	<u>15,461,293</u>	<u>13,086,905</u>
LESS: CURRENT LIABILITIES			
Sundry Creditors	(4,148,209)	(447,359)	(1,457,792)
Rates Income in Advance	0	(223,893)	(390,171)
GST Payable	0	(54,411)	(81,725)
Accrued Salaries & Wages	0	0	(143,994)
Accrued Interest on Debentures	0	(34,894)	(60,415)
Accrued Expenditure	0	(40,831)	(40,831)
Bond Liability	0	(734,656)	(722,287)
Payg Payable	0	2	0
Loan Liability	(464,582)	(98,491)	(368,947)
Provision for Annual Leave	0	(605,301)	(605,301)
Provision for Long Service Leave	0	(707,599)	(707,599)
Other Payables	0	0	(812,233)
	<u>(4,612,791)</u>	<u>(2,947,433)</u>	<u>(5,391,295)</u>
NET CURRENT ASSET POSITION	1,737,948	12,513,860	7,695,610
Less: Cash - Reserves - Restricted	(3,349,405)	(3,009,351)	(5,868,771)
Current Portion of Lease Liabilities	0	0	11,093
Less: Loans receivable - clubs/institutions	0	0	(27,519)
Add: Current Loan Liability	464,582	98,491	368,947
Add: Leave Liability Reserve	796,875	778,161	826,135
Add: Budgeted Leave	350,000	350,000	350,000
ESTIMATED SURPLUS/(DEFICIENCY) C/FWD	<u>0</u>	<u>10,731,161</u>	<u>3,355,495</u>

SHIRE OF NORTHAM
RATING REPORT
FOR THE PERIOD ENDED 28 February 2023

	2013/14	2014/15	2015/16	2016/17	2017/18	2018/19	2019/20	2020/21	2021/22	2022/23
Key Rating Dates										
RATES ISSUED	4/09/2013	14/08/14	14/08/15	19/08/2016	1/08/2017	15/08/2018	4/09/2019	7/08/2020	23/08/2021	2/09/2022
RATES DUE	23/10/2013	8/10/2014	25/09/2015	30/09/2016	14/09/2017	19/09/2018	9/10/2019	11/09/2020	29/09/2021	7/10/2022
2nd INSTALMENT DUE	23/12/2013	8/12/2014	25/11/2015	30/11/2016	14/11/2017	19/11/2018	9/12/2019	11/11/2020	29/11/2021	7/12/2022
3rd INSTALMENT DUE	24/02/2014	9/02/2015	25/01/2016	30/01/2017	15/01/2018	21/01/2018	10/02/2020	11/01/2021	31/01/2022	7/02/2023
4th INSTALMENT DUE	24/04/2014	9/04/2015	28/03/2016	30/03/2017	15/03/2018	21/03/2018	14/04/2020	11/03/2021	31/03/2022	12/04/2023
Outstanding 1st July	\$568,647	\$716,120	\$873,686	\$1,116,220	\$1,483,688	\$1,535,793	\$1,737,187	\$1,842,862	\$1,911,223	\$1,882,648
Rates Levied	\$7,758,147	\$8,222,616	\$8,552,189	\$8,931,257	\$9,564,551	\$9,925,046	\$10,342,585	\$10,381,252	\$10,676,737	\$11,272,726
Interest, Ex gratia, interim and back rates less writeoffs	\$73,630	\$80,154	\$83,173	\$208,077	-\$155,280	\$474,784	\$251,025	\$29,990	\$190,654	\$198,119
Rates paid by month										
1 July	47,443	62,554	29,105	43,333	60,002	94,638	87,543	307,979	94,808	90,363
2 August	23,961	119,840	700,198	367,776	2,054,983	1,856,869	213,195	2,343,849	462,892	397,332
3 September	1,152,416	2,650,420	4,519,842	4,243,288	3,764,731	4,014,835	2,829,221	4,326,537	5,819,112	3,666,388
4 October	3,790,646	2,550,091	630,886	1,166,136	484,607	590,724	3,255,037	208,486	756,888	3,478,258
5 November	444,497	506,022	842,856	908,844	1,036,340	952,902	574,138	580,253	1,041,532	720,389
6 December	685,338	654,900	214,507	336,154	189,794	239,893	724,440	437,028	465,088	655,106
7 January	194,157	295,629	441,681	464,526	637,664	861,146	427,789	643,946	794,760	570,266
8 February	502,176	508,828	148,327	260,963	258,355	174,143	576,493	323,242	316,347	713,091
9 March										
10 April										
11 May										
12 June										
Total YTD	6,840,634	7,348,284	7,527,403	7,791,018	8,486,476	8,785,150	8,687,857	9,171,321	9,751,427	10,291,193
% Ytd Rates Outstanding	18.6%	18.5%	20.8%	24.0%	22.1%	26.4%	29.5%	25.2%	23.7%	22.9%
Ytd Outstanding	1,559,790	1,670,605	1,981,644	2,464,536	2,406,484	3,150,474	3,642,940	3,082,783	3,027,188	3,062,300

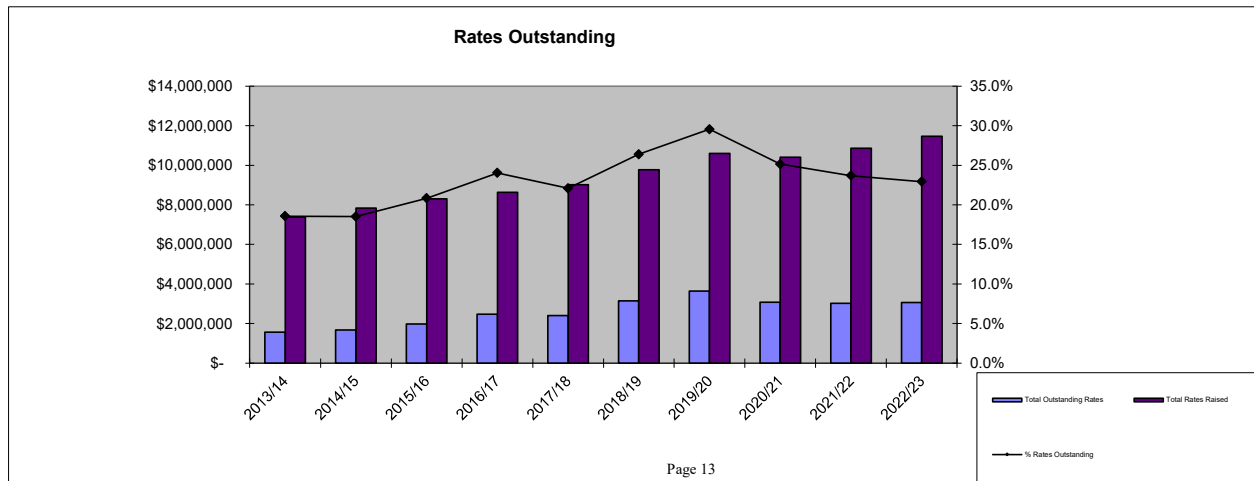

SHIRE OF NORTHAM
CASH FLOW REPORT
FOR THE PERIOD ENDED 31 JANUARY 2023

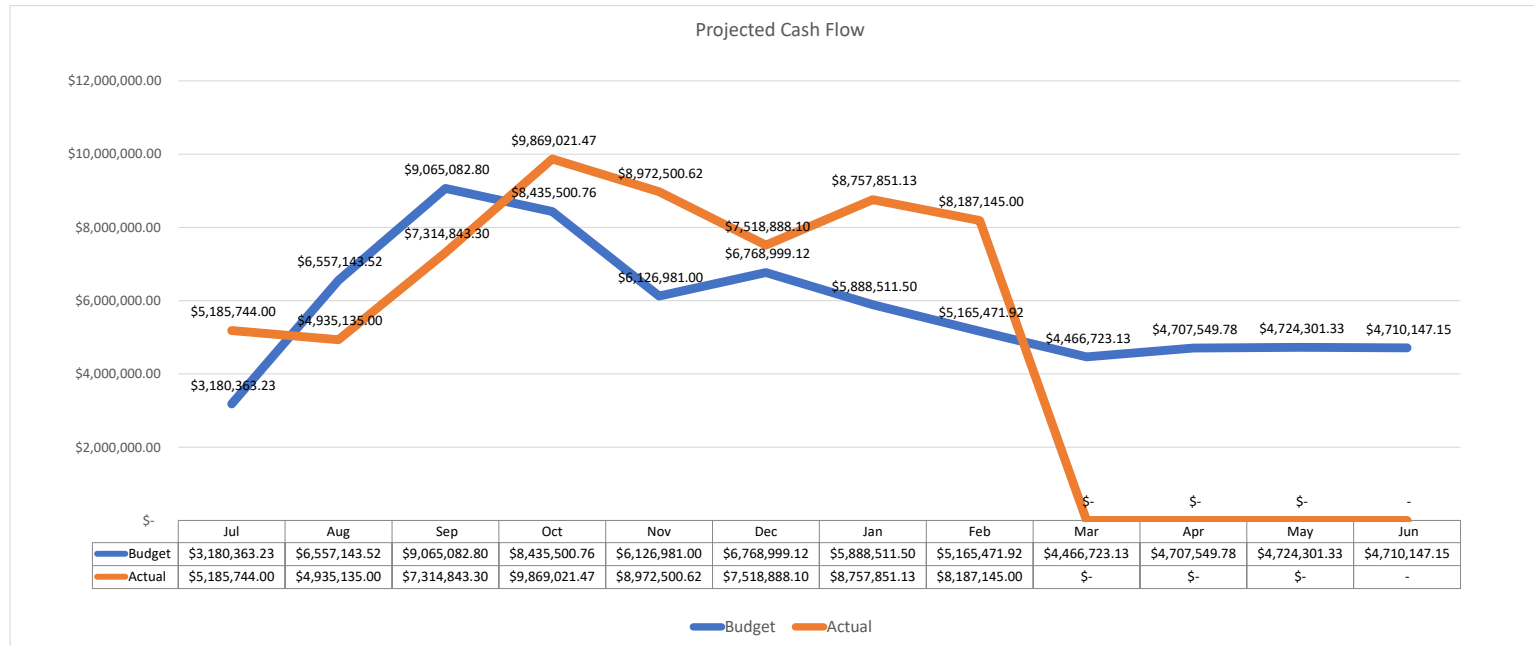

INVESTMENT REGISTER

Investor: **SHIRE OF NORTHAM** Ending Balance:

Starting Log Date: **01/07/22** Current Balance:

Current Date: **28/02/23**

Bank	INVESTING TERM		AMOUNT INVESTED	INTEREST RATE P.A	TERM TO MATURITY
	Start	End			MONTHS
Bendigo- Ref 3834910	29/11/22	29/03/23	\$250,810.84	3.75%	4
Bendigo Ref# 3834916	09/01/23	09/03/23	\$1,017,327.67	3.10%	2
Bendigo- Ref 3834911	30/06/22	30/03/23	\$2,658,688.46	3.45%	9
Bankwest- Ref 412001820-2	17/08/22	17/06/23	\$1,500,000.00	2.50%	10
Bankwest- Ref - 4120000269	17/02/23	17/04/23	\$1,011,288.79	2.40%	2
Bankwest TRUST AROC	16/02/23	16/03/23	\$142,062.13	2.20%	1
NAB	14/12/22	14/03/23	\$1,001,890.42	3.06%	3
NAB	10/10/22	10/05/23	\$1,000,000.00	3.20%	7
Total			\$8,582,068.31		

DISTRIBUTION OF INVESTMENTS 28/02/2023

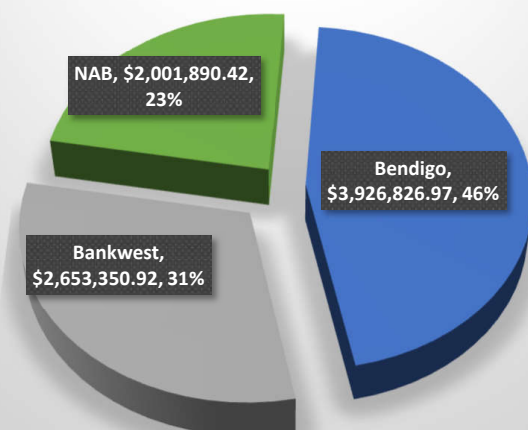

13.4.3 Budget Review 2022/23

File Reference:	8.2.7.1
Reporting Officer:	Colin Young (Executive Manager Corporate Services)
Responsible Officer:	Colin Young (Executive Manager Corporate Services)
Officer Declaration of Interest:	Nil
Voting Requirement:	Absolute Majority
Press release to be issued:	Yes

BRIEF

To consider and adopt the Budget Review as presented in the Statement of Financial Activity for the period 1 July 2021 to 31 January 2023.

ATTACHMENTS

1. Appendix Budget Review 2223 [**13.4.3.1** - 7 pages]

A. BACKGROUND / DETAILS

A Statement of Financial Activity incorporating year to date budget variations and forecasts to 30 June 2023 for the period ending 31 January 2023 is presented for council to consider. The *Local Government (Financial Management) Regulations 1996*, regulation 33A as amended, requires that local governments conduct a budget review between 1 January and 31 March in each financial year. A copy of the review and determination is to be provided to the Department of Local Government within 30 days of the adoption of the review.

B. CONSIDERATIONS

B.1 Strategic Community / Corporate Business Plan

Performance Area: Performance. Outcome 12: Excellence in organisational performance and customer service.

Objective 12.1: Maintain a high standard of corporate governance and financial management.

Priority Action 12.1.1: Provide the community with an annual explanation of the Shire's short and long term financial commitments and overall financial health.

Performance Area: Performance.

Outcome 12: Excellence in organisational performance and customer service.

Objective 12.3: Effectively manage the Shire's assets.

Priority Action 12.3.3: Provide well maintained Shire buildings.

Priority Action 12.3.4: Provide well maintained plant and equipment.

B.2 Financial / Resource Implications

The subsequent review will incorporate Budget amendments which will impact in accordance with the schedule provided.

B.3 Legislative Compliance

Section 6.4 and 6.26(2)(g) of the Local Government Act.

Regulation 33A of the Local Government (Financial Management) Regulations 1996 requires:

- (1) *Between 1 January and 31 March in each financial year a local government is to carry out a review of its annual budget for that year.*
- (2A) *The review of an annual budget for a financial year must —*
 - (a) *consider the local government's financial performance in the period beginning on 1 July and ending no earlier than 31 December in that financial year; and*
 - (b) *consider the local government's financial position as at the date of the review; and*
 - (c) *review the outcomes for the end of that financial year that are forecast in the budget.*
- (2) *Within 30 days after a review of the annual budget of a local government is carried out it is to be submitted to the council.*
- (3) *A council is to consider a review submitted to it and is to determine* whether or not to adopt the review, any parts of the review or any recommendations made in the review.*

**Absolute majority required.*

- (4) *Within 30 days after a council has made a determination, a copy of the review and determination is to be provided to the Department*

B.4 Policy Implications

Nil.

B.5 Stakeholder Engagement / Consultation

Nil.

B.6 Risk Implications

Risk Category	Description	Rating (likelihood x consequence)	Mitigation Action
Financial	Changes do not reflect the current position of Council.	Unlikely (2) x Minor (2) = Low (4)	Ensure that existing policies and processes are implemented and are compliant with relevant legislation and that there are sufficient funds to meet estimated expenditure for the remainder of the year.
Health & Safety	N/A	N/A	N/A
Reputation	N/A	N/A	N/A
Service Interruption	N/A	N/A	N/A
Compliance	All Council purchasing policies and guidelines have been adhered to	Unlikely (2) x Minor (2) = Low (4)	Unlikely (2) x Minor (2) = Low (4)
Property	N/A	N/A	N/A
Environment	N/A	N/A	N/A

B.7 Natural Environment Considerations

Nil.

C. OFFICER'S COMMENT

The budget review has been prepared to include information required by the *Local Government Act 1995*, *Local Government (Financial Management) Regulations 1996* and Australian Accounting Standards. Council adopted a 10% and a \$20,000 minimum for the reporting of material variances to be used in the statements of financial activity.

The budget has been reviewed to continue to deliver on other strategies adopted by the Council and maintains a high level of service across all programs.

The notes below correspond to the notes in the note column in recommended adjustments contained within Attachment 1. A revised Operating Statement (N&T) and Rate Setting Statement have been produced based on the recommended budget alterations below along with the budgeted reserve closing balances as of 30 June 2023.

Proposed Budget Review Amendment

Operating Expense Accounts

1. Following an extensive review of salaries and wages for the current financial year to January 2023, the following adjustments have been identified as specified below:
 - Corporate Services Salaries to reduce by \$135,000 due to vacancies of several senior staff for a combined period of 6 months, additionally structural realignment has produced savings within the administration customer service area.
 - A realignment of salary expenditure within Recreation Services seeing an overall increase of \$15,000 to offset the termination payment of a long term employee.
 - An Increase of \$30,000 for the CESM Salaries to offset the termination payment associated with a long term employee.
 - A reduction in Health Salaries of \$10,000 due to less hours worked that resulted from a position that was vacant for a period of time.
 - An increase in Planning Salaries due to the need to employ a contractor for a period greater than budgeted this resulted from Executive Manager acting in the position of Chief Executive Officer.
 - A re-alignment between Building Salaries and Building superannuation of \$10,000.
 - Increase in Visitor Centre salaries part due to an employee taking maternity leave, 24,000, disclosed at note 34 below.
 - Community Services Salaries have also increased by \$20,000 due to a long term employees termination payment.
 - Works Staff Salaries have also increased by \$20,000 and long service leave by \$20,000 also due to a long term employees termination payment.

The adjustments combined have a nil effect on the budget after taking into consideration the Information Technology's Trainee grant disclosed at note 35 below.

2. An additional \$10,000 is required to carry out a staff cultural survey, this has in the past been carried out bi-annually however after discussion with the executive managers group and recognising the benefits that it brings to the Shire it is recommended to move to an annual survey.

3. This budget has been increased due to the training requirements for the current employee whom was an internal appointment is and not qualified \$5,000.
4. Additional expenditure of \$2,000 required for the Wundowie community bus required to pay the driver for community bus service that was not budgeted for.
5. The Bernard Park Water Playground requires additional \$5,000 due to unexpected works to ensure the water park is compliant with regulations.
6. Verge Maintenance requires an increase of \$20,000 due to the need to remove/prune trees that were assessed a safety hazard in both urban and rural locations.
7. The following accounts have been increased upwards within schedule 14.
 - a. Expendable Tools and Equipment \$5,000
 - b. Tyres and Tubes \$5,000
 - c. Sundry Consumables \$5,000
 - d. Conference & Training \$10,000

Capital Expenditure

8.

<p>RECOMMENDATION / COUNCIL DECISION</p> <p>Minute No:C.4564</p> <p>Moved: Cr Mencshelyi Seconded: Cr Hughes</p> <p>That Council approve an unbudgeted expenditure of \$7,360 excluding GST to be identified in the 2022/23 mid-year budget review to facilitate the upgrade of the Northam Airport Wind Indicator and Windsock.</p> <p style="text-align: right;">CARRIED 8/0 BY ABSOLUTE MAJORITY</p>
--

9. Additional urgent works are required for the relocation of an electrical feeder line due to the installation of an LPG tank at Hanger 32 costing \$10,888, this was amended under Policy F4.11 Budget Variation Reporting by reducing the consultants budget 04042132, as such it is being requested to add the \$10,888 back to the consultants account.
10. Quotes for the sanding of the Wundowie Town Hall have come in over budget resulting in a \$3,000 increase to the budget.
11. Plant Replacement for the Hino dual Cab required the Budget to be Increased by \$40,000.
12. An allocation has been added for new hand-rails at Wundowie depot to due to being raised as a safety concern, \$6,000.

13. Street Bin Replacement, an allocation is needed to replace and upgrade unsightly bins with the CBD, \$13,200
14. Spencer Brook Road widening has come in over budget by \$33,897
15. Savings were made on Tamma Road, as such the budget has been reduced by \$27,900.
16. Due to the first signs of deterioration of the Henry St Oval retaining wall, it is recommended that it be treated (sealed) at a cost of \$17,000 to prevent further deterioration.

Accounts netted out and related transactions

17. The Superannuation expenditure for the Bushfire Mitigation Officer has been transferred to the correct account, nil impact on budget.
18. An amendment has been made for the purchase of the Bushfire Mitigation Officer's Vehicle due to the decision to Purchase outright rather leasing.
19. Various changes to the number of recreation purchases, it entitles bringing some forward from the 2023/24 year and pushing some out to the 2023/24 from 2022/23 financial year as per the table presented below;

Budget 22/23	
Rec Precinct Upgrades	50,000
Bert Hawke Oval/Hockey	50,000
Henry Street	75,000
Grandstand	80,000
Grant Revenue	- 40,000
	215,000
Ammended Budget 22/23	
Bert Hawke - storage	59,520
Hockey storage / dug outs	35,735
Grant Received (Sport & Recreation)	- 25,000
Bert Hawke - Shade	
Hockey Shade	
Grand Stands	50,262
Hockey - water provision	13,000
Hockey fencing	43,325
Football netting	22,749
Henry Street Scoreboard	
Reserve transfer	
Hockey Club contribution	- 15,000
Miscellaneous works at Rec Centre precinct	33,000
	217,591

20.

RECOMMENDATION / COUNCIL DECISION

Minute No:C.4631

Moved: Cr Mencshelyi

Seconded: Cr Appleton

That Council;

- 1. Receive the resignation of Cr Paul Curtis dated 25 November 2022 effective immediately and acknowledge his service on Council.**
- 2. In accordance with section 4.9(1)(b) of the *Local Government Act 1995*, fix 16 March 2023 as the date for an extraordinary election.**
- 3. Authorise an unbudgeted expenditure of \$14,000 including GST to conduct an extraordinary election from accounts 04042012 and 04042002, with an additional amount of \$6,500 being identified at the 2022/23 mid-year budget review.**
- 4. Declare, in accordance with section 4.20(4) of the *Local Government Act 1995*, the Electoral Commissioner to be responsible for the conduct of the Extraordinary Election.**
- 5. Determine, in accordance with section 4.61(2) of the *Local Government Act 1995* that the method of conducting the election will be as a postal election.**

**CARRIED 8/0
BY ABSOLUTE MAJORITY**

21. An increase in Stock sold at the Recreation Centre resulting in both revenue increased \$14,000 and expenditure increased by \$10,000, the same has occurred for the visitor Centre with both revenue and expenditure increasing by \$5,000.
22. An allocation for Wayfound Signage of \$20,000 has been moved for accounting purposes to a stand alone account, this has a nil impact on the budget.
23. Accounting for a \$33,000 grant received from the National Australia Day Council events on Australia Day including an allocation for an Auslan interpreter. The additional \$33,000 has been allocated to the Festivals and Events and is expected to be Spent on the Hot air Ballooning Shire run events and activations in May and September.
24. A reimbursement was received due to unforeseen circumstances related to the prepayment for purchase of a float Trailer of \$29,250, this was transferred against plant item PN1407 that was budgeted to be purchased in the 2021/22 financial year however carried over to the 2022/23 financial year.

25. Road works associated with Mitchell Avenue came in under budget by \$37,750, as it was grant funded the associated grant was reduced by \$19,727.

26.

RECOMMENDATION/COUNCIL DECISION

Minute No: C.4647

Moved: Cr Mencshelyi

Seconded: Cr Hughes

That Council:

- 1. Defer Grass Valley South Road, \$280,000 SLK 0.00 – 1.10 to the 2023/24 financial year and incorporate in the 2023/24 draft budget.**
- 2. Authorise an unbudgeted expenditure from Job 3125 (Grass Valley South Road SLK 0.00 – 1.10) to allocate to the following capital works:**
 - a. Lyon St SLK 0.00 – 0.60 \$8,383**
 - b. Markey St SLK 0.00 - 0.11 \$8,942**
 - c. Southern Brook Road SLK 16.33 – 17.30 \$197,000**
- 3. Reduce DRFAWA AGN 962 revenue by \$71,633.**
- 4. Authorise the remaining \$5,958 to be absorbed within the current budget.**

**CARRIED 7/0
BY ABSOLUTE MAJORITY**

27. Works associated with the Wundowie Oval Scheme Works where carried out by the Water Corporation at no cost to Council, in addition a grant has been received for a water reuse tank of \$85,000 with the total expenditure being \$127,600.

28. Council has received a bridge grant from Western Australian Grants Commission for Capital Works to be Carried out on the Old York Road Bridge of \$400,000, this will be paid to Main Roads WA as they will be carrying out the works, total cost \$600,000, with the additional \$200,000 paid by Main roads WA.

29. This allocation is to account for the payment and reimbursement of a dangerous goods licence paid by Council on behalf of the Northam Balloon Events Inc. For the LPG gas cylinder at the Northam Airstrip of \$5,016.

Transfer To/from Reserve

30.

RECOMMENDATION/COUNCIL DECISION

Minute No: C.4648

Moved: Cr Ryan
Seconded: Cr Mencshelyi

That Council resolve to:

- 1. Adopt the proposed amendments to the liquid waste disposal fees and charges effective from 1 March 2023 as follows:**

Liquid Waste Source	Proposed new charge:	Previous charge:
Local	\$0.10 per litre	\$0.08 per litre
Regional	\$0.12 per litre	\$0.08 per litre
Metro	\$0.14 per litre	\$0.08 per litre

Advertise the proposed amendments to the public pursuant to section 6.19 of the Local Government Act 1995.

- 2. Approve the unbudgeted expenditure of \$110,000 from the Septage Ponds reserve in accordance with the provisions of section 6.8 of the Local Government Act 1995 to carry out emergency works at the Old Quarry Road Liquid Waste Facility.**

CARRIED 7/0
BY ABSOLUTE MAJORITY

Operating Revenue Accounts

31. Additional Federal Assistance Grants were received above the estimate supplied by the Grants Commission, General Purpose \$86,616 and roads \$29,230.
32. Backs Rates of \$14,000 greater than budgeted have been received.
33. A contribution for Long Service Leave has been received from other Councils due to an employee termination \$14,187.
34. It is anticipated that the financial year will end with additional Rate Enquiry Fee revenue of \$10,000
35. The 2022/23 budget included revenue from the Old Pool House, this has been removed due to delays in construction works that are to be carried out.
36. Paternity leave has been received for Visitor Centre Manager whilst she is on maternity leave of \$14,000
37. A grant for an IT trainee was received for \$38,000, however most of the expenditure is expected to be received in the 2023/24 financial year and as per AASB 15 the expected expenditure of \$10,000 has been account for in the 2022/23.

38. Due to a large development application the budget for planning fees has been increase by \$22,269.
39. Killara Brokerage funding is greater than budgeted as such the budget has been increased \$110,000.
40. \$4,847 additional revenue was received from the Roads Direct Grant.
41. Due to Surplus funds in the regional pool the Grant associated with Jennapullin Road 2.58 – 3.19 SLK was increased by \$13,798.
42. Licensing income is expected to finish the year \$13,000 greater than budgeted.
43. A grant was received from Local Government Managers Australia towards the implementation of the Shire new Chart of Accounts.

Adjustment To EOFY Surplus

44. An adjustment was required due to movements in contract Liabilities and Accrued revenue to the value of \$104,467.

RECOMMENDATION / COUNCIL DECISION

Minute No: C.4696

Moved: Cr M P Ryan

Seconded: Cr M I Girak

That Council:

- 1. Receive the Budget Review for the eight (8) months ended 28 February 2023.**
- 2. Authorise the Chief Executive Officer to amend the 2022/23 Budget in accordance with the attached report titled Budget Review 2022/23.**

**BY ABSOLUTE MAJORITY
CARRIED 8/0**

**Shire of Northam
Budget Review
For the Year Ended June 2023**

TABLE OF CONTENTS

	Page
Budget Adjustments	2
Revised Statement of Comprehensive Income (N&T)	4
Revised Rate Setting Statement	5
Revised Statement of Comprehensive Income (Program)	6
Revised Reserve Balances	7

	Adopted Budget	RECOMMENDED ADJUSTMENTS BUDGET REVIEW 2022/23		Revised Budget
		Council Motion	Amendment	
Expense Accounts				
1 Corporate Services Salaries (04051002)	(\$ 1,025,579)		\$ 135,000	(\$ 890,579)
1 Northam Aquatic Facility Salaries (11331002)	(\$ 279,943)		\$ 10,000	(\$ 269,943)
1 Wundowie Pool Salaries (11331012)	(\$ 60,114)		\$ 10,000	(\$ 50,114)
1 Recreation Centre Salaries (11341002)	(\$ 314,992)		(\$ 30,000)	(\$ 344,992)
1 Recreation Superannuation (11341102)	(\$ 33,968)		(\$ 5,000)	(\$ 38,968)
1 CESH Salaries (05061002)	(\$ 197,926)		(\$ 30,000)	(\$ 227,926)
1 Health Wages (07141002)	(\$ 264,509)		\$ 10,000	(\$ 254,509)
1 Town Planning (10301002)	(\$ 432,541)		(\$ 40,000)	(\$ 472,541)
1 Building Salaries (13461002)	(\$ 171,383)		\$ 10,000	(\$ 161,383)
1 Building Superannuation (13461102)	(\$ 14,292)		(\$ 10,000)	(\$ 24,292)
1 Visitor Centre (13771012)	(\$ 243,575)		(\$ 24,000)	(\$ 267,575)
1 Community Services (13493002)	(\$ 339,319)		(\$ 20,000)	(\$ 359,319)
1 Works, LSL (14521322)	\$ -		(\$ 20,000)	(\$ 20,000)
1 Works Various	\$ -		(\$ 20,000)	(\$ 20,000)
2 Consultants, Staff Survey, (04042112)	(\$ 45,000)		(\$ 10,000)	(\$ 55,000)
3 Health Conference/Training (07142042)	(\$ 6,500)		(\$ 5,000)	(\$ 11,500)
4 Community Bus Wundowie (6391)	(\$ 5,088)		(\$ 2,000)	(\$ 7,088)
5 Water Park (11332202)	(\$ 5,000)		(\$ 5,000)	(\$ 10,000)
6 Verge Maintenance (5285)	(\$ 437,901)		(\$ 30,000)	(\$ 467,901)
7 Expendables Tools & Equipment (14532062)	(\$ 20,000)		(\$ 5,000)	(\$ 25,000)
7 Tyres & Tubes (14532042)	(\$ 28,000)		(\$ 5,000)	(\$ 33,000)
7 Sundry Consumables(14522062)	(\$ 7,250)		(\$ 5,000)	(\$ 12,250)
7 Conference & Training (14522052)	(\$ 65,523)		(\$ 10,000)	(\$ 75,523)
Sub total Expenditure	(\$ 3,998,403)		(\$ 101,000)	(\$ 4,099,403)
Capital Expenditure				
8 Airport Infrastructure (3507)	(\$ 14,500)	C.4564	(\$ 7,360)	(\$ 21,860)
9 Airport Infrastructure (3507), consultants (04042132)	(\$ 21,860)		(\$ 10,888)	(\$ 32,748)
10 Wundowie Floor Sanding (1811)	(\$ 13,500)		(\$ 3,000)	(\$ 16,500)
11 Hino Dual Cab Plant & Equip (12399004)	(\$ 60,000)		(\$ 40,000)	(\$ 100,000)
11 Profit on Sale of Asset (12396003)	\$ 46,645		(\$ 10,383)	\$ 36,262
11 Loss on Sale of Assets (12396012)	(\$ 121,463)		(\$ 29,617)	(\$ 151,080)
11 Non- Cash Adjustment Profit on Sale of Asset	\$ -		\$ 40,000	\$ 40,000
12 Wundowie Depot Safety Handrails (1960)	\$ -		(\$ 6,000)	(\$ 6,000)
13 Street Bin Replacement 1102620020	(\$ 8,159)		(\$ 13,200)	(\$ 21,359)
14 Spencers Brook Road (3680)	(\$ 1,413,692)		(\$ 33,897)	(\$ 1,447,589)
15 Tamma Road SLK 2.70 - 4.00 (7015)	(\$ 55,000)		\$ 27,900	(\$ 27,100)
16 Henry St Oval Wall (new job)	\$ -		(\$ 17,000)	(\$ 17,000)
Sub total Expenditure	(\$ 1,661,529)		(\$ 103,445)	(\$ 1,764,974)

	Adopted Budget	RECOMMENDED ADJUSTMENTS BUDGET REVIEW 2022/23		Revised Budget
		Council Motion	Amendment	
Accounts Netted Out & Related Transactions				
17 Fire Mitigation Expenditure (5536)	(\$ 62,036)		\$ 7,302	(\$ 54,734)
17 CESM Staff Costs (05061012)	(\$ 14,990)		(\$ 7,302)	(\$ 22,292)
18 Fire Mitigation Co-ordinator Expenditure (5536)	(\$ 54,734)		\$ 38,000	(\$ 16,734)
18 Purchase Plant & Equipment (05067014)	(\$ 115,000)		(\$ 51,000)	(\$ 166,000)
18 Trade Plant & Equipment (05067003)	\$ 36,500		\$ 13,000	\$ 49,500
18 Profit Sale of Asset (05066003)	\$ 8,000		\$ 13,000	\$ 21,000
18 Non- Cash Adjustment Profit on Sale of Asset	\$ -		(\$ 13,000)	(\$ 13,000)
19 Various Rec Centre Changes	(\$ 215,000)		(\$ 2,600)	(\$ 217,600)
20 Election Expenditure (04042062)	\$ -	C.4631	(\$ 14,000)	(\$ 14,000)
20 Members Allowances (04042002)	(\$ 57,000)	C.4631	\$ 7,500	(\$ 49,500)
21 Stock Northam Aquatic Facility (11332122)	(\$ 23,000)		(\$ 10,000)	(\$ 33,000)
21 Stock Revenue Northam Aquatic Facility (11333163)	\$ 30,000		\$ 14,000	\$ 44,000
21 Sale of Stock, Visitor centre (13773013)	\$ 20,000		\$ 5,000	\$ 25,000
21 Stock Visitor Centre (13772052)	(\$ 11,000)		(\$ 5,000)	(\$ 16,000)
22 Signage (4656)	(\$ 20,000)		\$ 20,000	\$ -
22 Signage (New Accountant)	\$ -		(\$ 20,000)	(\$ 20,000)
23 Grants, Australia Day Council (13453013)	\$ 40,000		\$ 33,000	\$ 73,000
23 Festivals and Events (13452172)	(\$ 199,000)		(\$ 33,000)	(\$ 232,000)
24 Plant Purchases (12399004)	(\$ 1,132,956)		(\$ 29,250)	(\$ 1,162,206)
24 Reimbursements (1145330130)	\$ 45,000		\$ 29,250	\$ 74,250
25 Mitchel Avenue slk 0.21-3.47 (3682)	(\$ 38,000)		\$ 37,750	(\$ 250)
25 Mitchel Avenue (12373013)	\$ 14,720		(\$ 19,727)	(\$ 5,007)
26 Lyon Street St 0-600 (3677)	\$ -	C.4647	(\$ 8,383)	(\$ 8,383)
26 Markey St 0-110 (3900)	\$ -	C.4647	(\$ 8,942)	(\$ 8,942)
26 Southern Brook RD SLK 16.33-17.30 (3905)	\$ -	C.4647	(\$ 197,000)	(\$ 197,000)
26 DRFAWA (WANDRRA) (1123730530)	\$ 2,945,994	C.4647	(\$ 71,633)	\$ 2,874,361
26 Grass Valley 0-1.1 (3125)	(\$ 280,000)	C.4647	\$ 280,000	\$ -
27 Wundowie oval Scheme Water conversion (6464)	(\$ 34,700)		(\$ 92,900)	(\$ 127,600)
27 Grants (11343093)-Wundowie oval water scheme	\$ 34,700		\$ 50,300	\$ 85,000
28 Bridges Expenditure (Old York Road), (12379064)	\$ -		(\$ 400,000)	(\$ 400,000)
28 Bridge Contribution (12373013)	\$ 171,000		\$ 400,000	\$ 571,000
29 Consultants (04042112)	(\$ 45,000)		(\$ 5,016)	(\$ 50,016)
29 Sundry Income (04043003)	\$ 1,300		\$ 5,016	\$ 6,316
Sub total Accounts Netted Out & Related Transactions				
Transfers To/From Reserve				
30 Transfer from Septage Pond Reserve	\$ -	C.4648	\$ 110,000	\$ 110,000
30 Septage Pond Maintenance (10262082)	(\$ 40,500)	C.4648	(\$ 110,000)	(\$ 150,500)
Sub total	\$ 1,004,298		(\$ 35,635)	\$ 968,663
Revenue Accounts				
31 FAG Roads (03023033)	\$ 150,530		\$ 29,230	\$ 179,760
31 FAG Grant General (03023023)	\$ 702,653		\$ 86,616	\$ 789,269
32 Back Rates (03013013)	\$ 1,000		\$ 15,000	\$ 16,000
33 LSL Contribution (04051503)	\$ 5,062		\$ 14,187	\$ 19,249
34 Rates Enquiry Fees (03013063)	\$ 60,000		\$ 10,000	\$ 70,000
35 Rental Housing (09233013)	\$ 10,400		(\$ 10,400)	\$ -
36 Paternal Leave (14552032)	\$ -		\$ 14,000	\$ 14,000
37 Trainee Grant (04053033)	\$ -		\$ 10,000	\$ 10,000
38 Planning Fees (10303003)	\$ 95,000		\$ 22,269	\$ 117,269
39 Killara Brokerage Income (08173093)	\$ 55,000		\$ 110,000	\$ 165,000
40 Roads Direct Grant (12383053)	\$ 225,325		\$ 4,847	\$ 230,172
41 RRG Grant (12373043)	\$ 478,396		\$ 13,798	\$ 492,194
42 Licensing Income (12413033)	\$ 185,000		\$ 20,000	\$ 205,000
43 Grants -DLG Mun (040430230)	\$ -		\$ 5,000	\$ 5,000
Sub total Revenue	\$ 1,968,366		\$ 344,547	\$ 2,312,913
Adjustment To End Of Year Surplus				
44 Surplus Budget			(\$ 4,090,543)	(\$ 4,090,543)
44 Accrued Revenue			(\$ 224,758)	(\$ 224,758)
44 Contract Liability			\$ 44,000	\$ 44,000
44 Contract Liability			\$ 35,000	\$ 35,000
44 Contract Liability			\$ 497,440	\$ 497,440
44 Surplus Actual			\$ 3,634,394	\$ 3,634,394
Sub total Adjustments/Untied Surplus			(\$ 104,467)	(\$ 104,467)
Net Change to Budget	(\$ 2,687,268)	\$ -	\$ -	(\$ 2,687,268)

Shire of Northam
Statement Of Comprehensive Income
By Nature and Type
For the Year Ending 30th June 2023

	2022/23 Original Budget \$	2022/23 Amendments \$	2022/23 Revised Budget \$
REVENUE			
Rates	11,360,033	15,000	11,375,033
Operating Grants & Subsidies & Contributions	6,172,224	238,513	6,410,737
Fees and Charges	4,416,789	170,869	4,587,658
Interest Earnings	325,000	0	325,000
Other Revenue	1,079,015	0	1,079,015
	<u>23,353,061</u>	<u>424,382</u>	<u>23,777,443</u>
EXPENSES			
Employee Costs	(9,681,211)	(24,000)	(9,705,211)
Materials and Contracts	(8,702,468)	(208,516)	(8,910,984)
Utility Charges	(1,167,337)	0	(1,167,337)
Depreciation	(5,080,238)	0	(5,080,238)
Interest Expenses	(253,065)	0	(253,065)
Insurance Expenses	(556,858)	0	(556,858)
Other Expenditure	(225,549)	0	(225,549)
	<u>(25,666,726)</u>	<u>(232,516)</u>	<u>(25,899,242)</u>
	(2,313,665)	191,866	(2,121,799)
Non-Operating Grants, Subsidies and Contributions	5,246,091	717,053	5,963,144
Profit on Asset Disposals	54,645	2,617	57,262
Loss on Asset Disposals	(124,463)	(29,617)	(154,080)
	<u>2,862,608</u>	<u>881,919</u>	<u>3,744,527</u>
NET RESULT	2,862,608	881,919	3,744,527
Other Comprehensive Income	0	0	0
TOTAL COMPREHENSIVE INCOME	<u>2,862,608</u>	<u>881,919</u>	<u>3,744,527</u>

This statement is to be read in conjunction with the accompanying notes.

Shire of Northam
Revised Rate Setting Statement
By Nature and Type
For the Year Ending 30th June 2023

	2022/23 Original Budget \$	2022/23 Ammendments \$	2022/23 Revised Budget \$
REVENUE			
Rates	27,307	15,000	42,307
Operating Grants & Subsidies & Contributions	6,172,224	238,513	6,410,737
Fees and Charges	4,416,789	170,869	4,587,658
Interest Earnings	325,000	0	325,000
Other Revenue	1,079,015	0	1,079,015
	<u>12,020,335</u>	<u>424,382</u>	<u>12,444,717</u>
EXPENSES			
Employee Costs	(9,681,211)	(24,000)	(9,705,211)
Materials and Contracts	(8,702,468)	(208,516)	(8,910,984)
Utility Charges	(1,167,337)	0	(1,167,337)
Depreciation	(5,080,238)	0	(5,080,238)
Interest Expenses	(253,065)	0	(253,065)
Insurance Expenses	(556,858)	0	(556,858)
Other Expenditure	(225,549)	0	(225,549)
	<u>(25,666,726)</u>	<u>(232,516)</u>	<u>(25,899,242)</u>
	(13,646,391)	191,866	(13,454,525)
Non-Operating Grants, Subsidies and Contributions	5,246,091	717,053	5,963,144
Profit on Asset Disposals	54,645	2,617	57,262
Loss on Asset Disposals	(124,463)	(29,617)	(154,080)
Net Operating Result Excluding Rates	(8,470,118)	881,919	(7,588,199)
Adjustments for Cash Budget Requirements:			
Non-Cash Expenditure and Revenue			
(Profit)/Loss on Asset Disposals	69,818	27,000	96,818
Depreciation on Assets	5,080,238	0	5,080,238
Capital Expenditure and Revenue			
Purchase Land and Buildings	(3,166,027)	(9,000)	(3,175,027)
Purchase Infrastructure Assets - Roads	(7,326,591)	97,428	(7,229,163)
Purchase Infrastructure Assets - Bridges & Culverts	0	(400,000)	(400,000)
Purchase Infrastructure Assets - Footpaths	(259,628)	0	(259,628)
Purchase Infrastructure Assets - Drainage	(2,456,593)	0	(2,456,593)
Purchase Infrastructure Assets - Parks	(2,218,734)	(17,000)	(2,235,734)
Purchase Infrastructure Assets - Other	(416,105)	(126,948)	(543,053)
Purchase Plant and Equipment	(1,314,956)	(120,250)	(1,435,206)
Purchase Furniture and Equipment	(162,500)	0	(162,500)
Proceeds from Disposal of Assets	379,000	13,000	392,000
Proceeds New Debentures	2,700,000	0	2,700,000
Repayment of Debentures	(407,957)	0	(407,957)
Self-Supporting Loan Principal Income	21,518	0	21,518
Proceeds Community Advance	6,000	0	6,000
Transfers to Reserves (Restricted Assets)	(340,054)	0	(340,054)
Transfers from Reserves (Restricted Assets)	2,859,420	110,000	2,969,420
Estimated Surplus/(Deficit) July 1 B/Fwd	4,090,543	(456,149)	3,634,394
Estimated (Surplus)/Deficit June 30 C/Fwd	0	0	0
Amount Required to be Raised from Rates	(11,332,726)	0	(11,332,726)

This statement is to be read in conjunction with the accompanying notes.

Shire of Northam
Operating Income and Expenses
By Function and Activity
For the Year Ending 30th June 2023

	2022/23 Original Budget \$	2022/23 Amendments \$	2022/23 Revised Budget \$
REVENUES			
Governance	30,070	34,203	64,273
General Purpose Funding	12,712,487	140,846	12,853,333
Law, Order, Public Safety	1,290,840	13,000	1,303,840
Health	61,000	0	61,000
Education and Welfare	1,200,818	110,000	1,310,818
Housing	62,277	(10,400)	51,877
Community Amenities	3,034,721	22,269	3,056,990
Recreation and Culture	607,793	58,000	665,793
Transport	3,518,264	24,847	3,543,111
Economic Services	705,236	4,984	710,220
Other Property and Services	184,200	29,250	213,450
	<u>23,407,706</u>	<u>426,999</u>	<u>23,834,705</u>
CAPITAL GRANTS			
Law, Order, Public Safety	841,232	0	841,232
Recreation and Culture	1,165,840	50,300	1,216,140
Transport	3,204,019	584,737	3,788,756
Economic services	35,000	82,016	117,016
	<u>5,246,091</u>	<u>717,053</u>	<u>5,963,144</u>
TOTAL REVENUE	<u>28,653,797</u>	<u>1,144,052</u>	<u>29,797,849</u>
EXPENSES			
Governance	(2,409,672)	123,484	(2,286,188)
General Purpose Funding	(321,096)	(30,000)	(351,096)
Law, Order, Public Safety	(2,484,548)	8,000	(2,476,548)
Health	(390,849)	5,000	(385,849)
Education and Welfare	(1,368,049)	0	(1,368,049)
Housing	(72,696)	0	(72,696)
Community Amenities	(4,049,132)	(150,000)	(4,199,132)
Recreation & Culture	(5,337,630)	(25,000)	(5,362,630)
Transport	(6,587,228)	(29,617)	(6,616,845)
Economic Services	(2,719,820)	(94,000)	(2,813,820)
Other Property and Services	(50,469)	(70,000)	(120,469)
	<u>(25,791,189)</u>	<u>(262,133)</u>	<u>(26,053,322)</u>
NET RESULT	2,862,608	881,919	3,744,527
Other Comprehensive Income	0	0	0
TOTAL COMPREHENSIVE INCOME	<u>2,862,608</u>	<u>881,919</u>	<u>3,744,527</u>

This statement is to be read in conjunction with the accompanying notes.

Shire of Northam
Revised Reserve Account Balances
For the Year Ending 30th June 2023

	2022/23	2022/23	2022/23
RESERVES - CASH BACKED	Budget	Movement	Revised Budget
	\$	\$	\$
Employee Liability Reserve	796,875		796,875
Housing Reserve			-
Reticulation Scheme Reserve	241,656		241,656
Office Equipment Reserve	102,268		102,268
Plant & Equipment Reserve	121,917		121,917
Road & Bridgeworks Reserve	204,534		204,534
Refuse Site Reserve	495,803		495,803
Regional Development Reserve	-		-
Speedway Reserve	153,993		153,993
Community Bus Replacement Reserve	102,369		102,369
Septage Pond Reserve	311,116	- 110,000	201,116
Killara Reserve	400,591		400,591
Stormwater Drainage Projects Reserve	-		-
Recreation and Community Facilities Reserve	28,511		28,511
Administration Office Reserve	-		-
Council Buildings & Amenities Reserve	284,791		284,791
River Town Pool Dredging Reserve			-
Parking Facilities Construction Reserve	102,267		102,267
Art Collection Reserve	-		-
Election Reserve	-		-
Revaluation Reserve	2,714		2,714
Covid 19 Reserve	-		-
Total Cash Backed Reserves	3,349,405	(110,000)	3,239,405

13.5 COMMUNITY SERVICES

13.5.1 Financial support for the 2023 National Ballooning Championships

File Reference:	1.3.2.16
Reporting Officer:	Jo Metcalf (Executive Manager Community Services)
Responsible Officer:	Jo Metcalf (Executive Manager Community Services)
Officer Declaration of Interest:	Nil.
Voting Requirement:	Absolute Majority
Press release to be issued:	No

BRIEF

For Council to consider providing financial support for the 5th FAI Women's World Hot Air Ballooning Championships (WWHABC).

ATTACHMENTS

1. Letter from Northam Ballooning Events (NBE) for Sponsorship. [**13.5.1.1** - 2 pages]
2. CONFIDENTIAL REDACTED - Budget 2023 Womens Worlds updated Feb 2023 (Available on Request) [**13.5.1.2** - 3 pages]
3. CONFIDENTIAL REDACTED - Woman s World Ballooning Championship Funding Correspondance [**13.5.1.3** - 1 page]

A. BACKGROUND / DETAILS

The Northam Ballooning Events Inc. is requesting \$40,000 in support from the Shire of Northam for the WWHABC in September 2023. The Shire has also contributed \$40,000 to the National Hot Air Ballooning Championships due to take place in Northam in May 2023.

NBE has secured funding from Tourism WA and are seeking additional funding to deliver the September event.

Previous contributions by the Shire of Northam (& State Government) are as follow:

- 2015 National Championships \$15,000 (Eventscorp \$82,995)
- 2017 National Championships \$20,000 (Eventscorp \$100,000)
- 2021/23 National Championships \$40,000 (Tourism WA \$90,000)

- 2021/23 Women's Worlds (Tourism WA \$210,000).

B. CONSIDERATIONS

B.1 Strategic Community / Corporate Business Plan

Performance Area: Prosperity.

Outcome 10: An attractive destination for investors, business and visitors; helping to grow the economy and local jobs.

Objective 10.4: Identify develop and promote tourism experiences and supporting services.

Priority Action 10.4.1: Advocate for a national or international ballooning event in Northam every two years.

B.2 Financial / Resource Implications

If supported, this allocation would need to be included in the 2023/24 budget.

B.3 Legislative Compliance

Local Government Act 1995, section 6.8 - Expenditure from municipal fund not included in annual budget.

B.4 Policy Implications

Nil.

B.5 Stakeholder Engagement / Consultation

Nil.

B.6 Risk Implications

Risk Category	Description	Rating (likelihood x consequence)	Mitigation Action
Financial	Nil.		
Health & Safety	Nil.		
Reputation	Council is seen as being unsupportive of major international event.	Medium (3) x Possible (3) = Moderate (9)	Council provide financial support to the NBE Championships as the key delivery partner for the event.
Service Interruption	Nil.		
Compliance	Nil.		
Property	Nil.		
Environment	Nil.		

B.7 Natural Environment Considerations

Nil.

C. OFFICER'S COMMENT

This financial support will ensure the successful delivery of the championships and allow NBE to undertake the necessary planning and logistical activities for the competition.

The WWHABC will position Northam as a significant hot air ballooning destination in the Southern Hemisphere and attract major media and community profile and the subsequent economic impact.

Spectator figures are based on estimated attendances during the 2017 Australian National Ballooning Championships. It is anticipated that a larger number of international visitors will attend this event than for the National Championship events previously held in Northam, given the World Championship status of the competition. This will include competitors, crew members, and spectators.

The Estimated Event Visitation and Economic Impact for the event when it was originally planned for 2021 was that approximately 20,000 visitors would bring a direct spend of more than \$2.6million to the region.

NBE has secured funding from Tourism WA and will also be seeking additional corporate sponsorship.

This request is specifically for the delivery of the competition element of the event and additional resource and budget will be required for the Shire of Northam to deliver the activation elements associated with the event, for which NBE is not responsible, such as a balloon 'glow', entertainment and community engagement.

In line with the discussion at the Council forum, Northam Ballooning Events have revised their request for financial support. The request has been adjusted from a request to underwrite for \$100,000 to a request for a direct grant of \$40,000.

RECOMMENDATION / COUNCIL DECISION

Minute No: C.4697

Moved: Cr A J Mencshelyi

Seconded: Cr H J Appleton

That Council allocate \$40,000 in the 2023/2024 Draft Budget for Northam Ballooning Events Inc. to hold the 5th FAI Women's World Hot Air Ballooning Championships.

**BY ABSOLUTE MAJORITY
CARRIED 8/0**

One member of gallery, Mr W Jones, left the meeting at 6:05 pm



Chief Executive Officer
Shire of Northam
PO Box 613
NORTHAM WA 6401

19 January 2023

Dear Jason,

In 2019 Northam Ballooning Events (NBE), with support from the Shire of Northam, made a successful bid to host the 5th FAI Women's World Hot Air Ballooning Championship in 2021. The global outbreak of Covid 19 resulted in the postponement of the Championship until September 2023.

Subsequently, in 2020, the Australian Ballooning Federation (ABF) approached NBE to host the 23rd Australian National Ballooning Championships in 2021, as a Tasmanian bid had been withdrawn. NBE received funding from Tourism WA and from the Shire of Northam, along with a number of local business sponsors, to enable the running of this National event in Northam. Covid 19 lockdowns in NSW & VIC resulted in this event also being postponed. The Nationals event has been rescheduled for May 2023, and despite a number of unforeseen cost increases, we are managing to meet budget forecasts, with a minor shortfall to be met by the inclusion of additional local small business sponsorship.

NBE is now seeking Council's financial support for the second, and more globally significant event in 2023, the 5th FAI Women's World Hot Air Ballooning Championship. This will be held in the first week of September 2023, and it is anticipated that 45 of the best women pilots from around the globe will participate. National Aero Clubs around the world have been invited to submit nominations, with a closing date at the end of this month. To date we have received a full quota of nominations from the UK, US, Austria, Poland, Lithuania and Australia.

We have again gained significant financial support from Tourism WA, and have identified a number of smaller corporate sponsors, but there is currently a budget shortfall of \$100,000. This is due to changing circumstances from those in 2021.

As you have probably been made aware by Council's rep on Committee, there are issues with regards to the supply of LPG to competitors (to be provided at no charge to them) which will result in a tripling of that cost; and also the changes to the accommodation available at Muresk Institute. We have committed to the supply of accommodation for the teams at no charge, with the budget based on booking the entirety of the halls at Muresk. We are now only able to book 20 single rooms, resulting in a quadrupling of cost.

The World Championship event will be a huge stage for Northam, providing benefits for local businesses and community, and global exposure for our hub at the centre of the beautiful Avon Valley. So we ask that Council consider assisting, with the provision of financial support that will offset our current shortfall.

Yours sincerely

ERROL CROFT
Chairman

Northam Ballooning Events Inc.
PO Box 1040 NORTHAM WA 6401
northamballooningevents@gmail.com



14 MATTERS BEHIND CLOSED DOORS

RECOMMENDATION / COUNCIL DECISION

Minute No: C.4698

Moved: Cr D J Galloway

Seconded: Cr A J Mencshelyi

That Council, in accordance with section 11.1(i) of the Shire of Northam Standing Orders Local Law 2018 and Section 5.23 (2) (A) and (C) of the Local Government Act 1995, meet behind closed doors to consider agenda items:

- 14.1 - Financier's Side Deed – Northam Country Club, 15 Wood Drive, Northam – as it related to a contract entered into, or which may be entered into, by the local government and which relates to a matter to be discussed at the meeting.
- 14.2 - Chief Executive Officer Review Committee meeting held on 15 February 2023 – as it is a matter affecting an employee or employees.
- 14.3 - Chief Executive Officer Review Committee meeting held on 08 March 2023 – as it is a matter affecting an employee or employees.

CARRIED 8/0

Members of the gallery left the meeting at 6:06 pm.

14.1 FINANCIER'S SIDE DEED - NORTHAM COUNTRY CLUB, 15 WOOD DRIVE, NORTHAM

RECOMMENDATION / COUNCIL DECISION

Minute No: C.4699

**Moved: Cr M P Ryan
Seconded: Cr A J Mencshelyi**

That Council authorise the Chief Executive Officer and Shire President to execute the Financier's Side Deed subject to:

- 1. Section 2. Statement of intent and purpose being amended to include:**

"2.3 Condition precedent

The parties covenant and agree that the obligations under this Deed are conditional upon execution of the Deed of Assignment."

- 2. 9.3 Legal Costs being amended to include:**

"(b) The Owner covenants and agrees to pay the Mortgagee's reasonable legal costs in the review of this Deed."

CARRIED 8/0

Members of the Staff left the meeting at 6:10 pm.

14.2 CHIEF EXECUTIVE OFFICER REVIEW COMMITTEE MEETING HELD ON 15 FEBRUARY 2023

Receipt of Minutes:

RECOMMENDATION / COUNCIL DECISION

Minute No: C.4700

Moved: Cr C R Antonio

That Council receive the minutes from the Chief Executive Officer Review Committee meeting held on 15 February 2023.

CARRIED 8/0

Adoption of Recommendations:

RECOMMENDATION / COUNCIL DECISION

Minute No: C.4701

Moved: Cr C R Antonio

That Council:

1. Accept the minutes of the Chief Executive Officer Review Committee meeting held on 25 January 2023 be confirmed as a true and correct record of that meeting.
2. Authorise the Shire President to write to the Chief Executive Officer requesting written acceptance to amend his current contract of employment with the Shire of Northam, by amending the commencement date from 03/09/2018 to 01/03/2023, and the end date from 02/09/2023 to 29/02/2028.
3. Authorise the matter regarding the Chief Executive Officer's current contract of employment with the Shire of Northam be raised as a matter of urgent business, and behind closed doors, at the Ordinary Council Meeting to be held on Wednesday 15 February 2023.

CARRIED 8/0

14.3 CHIEF EXECUTIVE OFFICER REVIEW COMMITTEE MEETING HELD ON 08 MARCH 2023

Receipt of Minutes:

RECOMMENDATION / COUNCIL DECISION

Minute No: C.4702

Moved: Cr C R Antonio

That Council receive the minutes from the Chief Executive Officer Review Committee meeting held on 08 March 2023.

CARRIED 8/0

Adoption of Recommendations:

RECOMMENDATION / COUNCIL DECISION

Minute No: C.4703

Moved: Cr M P Ryan

Seconded: Cr D J Galloway

That Council:

1. Accepts the minutes of the Chief Executive Officer Review Committee meeting held on 15 February 2023 be confirmed at a true and correct record of that meeting.
2. Advise Mills Recruitment that their quote of \$17,400 plus GST and advertising and incidentals is accepted and request they provide executive recruitment services for the upcoming Shire of Northam's Chief Executive Officer Recruitment Process.
3. Authorise an unbudgeted expenditure of \$17,400 plus GST from account 04042132 (consultants) to undertake the Chief Executive Officer recruitment process.

BY ABSOLUTE MAJORITY
CARRIED 8/0

Reason for Change to Committee Recommendation

With respect to item 3 of the Committee Recommendation, the committee is proposing to commence this process in April 2023 with an 8 week timeline. This will result in the process being concluded in June 2023 and as such the full amount will be required in the 2022/23 budget. Officers recommend that

Council authorise an unbudgeted expenditure (by Absolute Majority) as the mid-year budget review has been finalised.

RECOMMENDATION / COUNCIL DECISION

Minute No: C.4704

Moved: Cr A J Mencshelyi

Seconded: Cr H J Appleton

That Council move out from behind closed doors.

CARRIED 8/0

Members of the Staff and 1 member of the gallery returned to the meeting at 6:20 pm.

15 MOTIONS OF WHICH PREVIOUS NOTICE HAS BEEN GIVEN

Nil.

16 URGENT BUSINESS APPROVED BY DECISION

Nil.

17 DECLARATION OF CLOSURE

There being no further business, the Shire President, Cr C R Antonio, declared the meeting closed at 6:20 pm.

"I certify that the Minutes of the Ordinary Meeting of Council held on 15 March 2023 have been confirmed as a true and correct record."



President

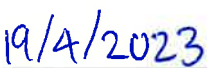

Date