



Shire of Northam  
*Heritage, Commerce and Lifestyle*

## **Shire of Northam**

### **Agenda**

### **Ordinary Council Meeting**

**17 August 2022**



**NOTICE PAPER**  
**Ordinary Council Meeting**  
**17 August 2022**

President and Councillors

I inform you that an Ordinary Council meeting will be held in the Council Chambers, located at 395 Fitzgerald Street, Northam on 17 August 2022 at 5:30pm.

There will be a Forum meeting held in the Council Chambers on 10 August 2022 at 5:30pm to discuss the contents of this agenda.

Yours faithfully



**Jason Whiteaker**  
**Chief Executive Officer**

## DISCLAIMER

This agenda has yet to be dealt with by the Council. The Recommendations shown at the foot of each item have yet to be considered by the Council and are not to be interpreted as being the position of the Council. The minutes of the meeting held to discuss this agenda should be read to ascertain the decision of the Council.

In certain circumstances members of the public are not entitled to inspect material, which in the opinion of the Chief Executive Officer is confidential, and relates to a meeting or a part of a meeting that is likely to be closed to members of the public.

No responsibility whatsoever is implied or accepted by the Shire of Northam for any act, omission, statement or intimation occurring during Council or Committee meetings.

The Shire of Northam disclaims any liability for any loss whatsoever and howsoever caused arising out of reliance by any person or legal entity on any such act, omission or statement of intimation occurring during Council or Committee meetings.

Any person or legal entity who acts or fails to act in reliance upon any statement, act or omission made in a Council or Committee meeting does so at that person's or legal entity's own risk.

In particular and without derogating in any way from the broad disclaimer above, in any discussion regarding any planning application or application for a licence, any statement or intimation of approval made by any member or Officer of the Shire of Northam during the course of any meeting is not intended to be and is not taken as notice of approval from the Shire of Northam.

The Shire of Northam advises that anyone who has any application lodged with the Shire of Northam must obtain and should only rely on WRITTEN CONFIRMATION of the outcome of the application and any conditions attaching to the decision made by the Shire of Northam in respect of the application.

The Shire of Northam advises that any plans or documents contained within this agenda may be subject to copyright law provisions (*Copyright Act 1968*, as amended) and that the express permission of the copyright owner(s) should be sought prior to their reproduction. It should be noted that copyright owners are entitled to take legal action against any persons who infringe their copyright. A reproduction of material that is protected by copyright may represent a copyright infringement.

## Contents

|        |   |    |
|--------|---|----|
| 1.     | DECLARATION OF OPENING.....   | 6  |
| 2.     | ACKNOWLEDGEMENT TO COUNTRY.....   | 6  |
| 3.     | ATTENDANCE.....   | 6  |
| 3.1    | APOLOGIES.....  | 6  |
| 3.2    | APPROVED LEAVE OF ABSENCE.....  | 6  |
| 3.3    | ABSENT.....   | 6  |
| 4.     | DISCLOSURE OF INTERESTS.....  | 6  |
| 5.     | ANNOUNCEMENT BY THE PRESIDING MEMBER (WITHOUT DISCUSSION) ...                                   | 9  |
| 6.     | PUBLIC QUESTION TIME.....   | 11 |
| 6.1    | PUBLIC QUESTIONS.....   | 11 |
| 7.     | RESPONSE TO PREVIOUS PUBLIC QUESTIONS TAKEN ON NOTICE.....                                      | 11 |
| 8.     | RECEIVING OF PETITIONS, PRESENTATIONS AND DEPUTATIONS.....                                      | 11 |
| 8.1    | PETITIONS.....  | 11 |
| 8.2    | PRESENTATIONS.....  | 11 |
| 8.3    | DEPUTATIONS.....  | 11 |
| 9.     | APPLICATION FOR LEAVE OF ABSENCE.....   | 11 |
| 10.    | CONFIRMATION OF MINUTES.....  | 11 |
| 10.1   | ORDINARY COUNCIL MEETING HELD 20 JULY 2022.....   | 11 |
| 10.2   | SPECIAL COUNCIL MEETING HELD 27 JULY 2022.....  | 11 |
| 10.3   | NOTES FROM COUNCIL FORUM MEETING HELD 10 AUGUST 2022... ..                                      | 11 |
| 11.    | ITEMS BROUGHT FORWARD FOR THE CONVENIENCE OF THOSE IN THE PUBLIC GALLERY.....                   | 29 |
| 12.    | REPORTS OF COMMITTEE MEETINGS.....  | 29 |
| 12.1   | NYOONGAR CULTURAL ADVISORY GROUP COMMITTEE MEETING HELD ON 14 MAY 2022.....                     | 29 |
| 13.    | OFFICER REPORTS.....  | 61 |
| 13.1   | CEO'S Office.....   | 61 |
| 13.1.1 | Lease Agreement for Northam Pistol Club, Portion of Reserve 3303, 98 Clarke Street Northam..... | 61 |
| 13.2   | ENGINEERING SERVICES.....   | 66 |
| 13.2.2 | RFQ 10 of 2022 Spencers Brook Road Spray Seal & Asphalt Works.....                              | 66 |
| 13.3   | DEVELOPMENT SERVICES.....   | 70 |

|        |  |     |
|--------|--|-----|
| 13.3.1 | Proposed Amendment – Co-Operative Bulk Handling,<br>Leeming Road, Grass Valley ..... | 70  |
| 13.3.2 | Proposed Review of the Heritage List .....   | 136 |
| 13.4   | CORPORATE SERVICES.....  | 160 |
| 13.4.1 | Accounts & Statements of Accounts 1 July 2022 to 31 July<br>2022.....                | 160 |
| 13.5   | COMMUNITY SERVICES .....   | 233 |
| 13.5.1 | Nyoongar Cultural Advisory Group .....   | 233 |
| 14.    | MATTERS BEHIND CLOSED DOORS .....  | 244 |
| 14.1   | LEASE OF A PORTION OF RESERVE 44700 .....  | 244 |
| 14.2   | UNAUTHORISED STRUCTURE – A72.....  | 244 |
| 15.    | MOTIONS OF WHICH PREVIOUS NOTICE HAS BEEN GIVEN.....                                 | 244 |
| 15.1   | FENCED DOG PARK .....  | 244 |
| 16.    | URGENT BUSINESS APPROVED BY DECISION.....  | 264 |
| 17.    | DECLARATION OF CLOSURE.....  | 264 |



## 1. DECLARATION OF OPENING

## 2. ACKNOWLEDGEMENT TO COUNTRY

The Shire of Northam would like to acknowledge the Traditional Owners of the land on which we meet, the Ballardong and Whadjuk people of the Nyoongar nation and pay our respects to Elders, past present and emerging.

## 3. ATTENDANCE

### Council:

Shire President  
Deputy Shire President  
Councillors

C R Antonio  
M P Ryan  
D Galloway  
R W Tinetti  
A J Mencshelyi  
M I Girak  
J E G Williams  
D A Hughes  
H Appleton  
P Curtis

### Staff:

|  |               |
|--|---------------|
| Chief Executive Officer                | J B Whiteaker |
| Executive Manager Engineering Services | S Patterson   |
| Executive Manager Development Services | C B Hunt      |
| Executive Manager Community Services   | J Metcalf     |
| Executive Manager Corporate Services   | C Young       |
| Acting Governance Officer              | T P Van Beek  |
| Acting Governance Coordinator          | A C McCall    |

### 3.1 APOLOGIES

Nil

### 3.2 APPROVED LEAVE OF ABSENCE

Nil.

### 3.3 ABSENT

Nil.

## 4. DISCLOSURE OF INTERESTS

*Members should fill in Disclosure of Interest forms for items in which they have a financial, proximity or impartiality interest and forward these to the Presiding Member before the meeting commences.*

As defined in section 5.60A of the Local Government Act 1995, a **financial interest** occurs where a Councillor / Committee Member, or a person with whom the Councillor / Committee Member is closely associated, has a direct or indirect financial interest in the matter. That is, the person stands to make a financial gain or loss from the decision, either now or at some time in the future.

As defined in section 5.61 of the Local Government Act 1995, an **indirect financial interest** includes a reference to a financial relationship between that person and another person who requires a Local Government decision in relation to the matter.

As defined in section 5.60B of the Local Government Act 1995, a person has a **proximity interest** in a matter if the matter concerns a proposed change to a planning scheme affecting land that adjoins the person's land; or a proposed change to the zoning or use of land that adjoins the person's land; or a proposed development (as defined in section 5.63(5)) of land that adjoins the person's land.

As defined in 34C of the Local Government (Administration) Regulations 1996, an **impartiality interest** means an interest that could, or could reasonably be perceived to, adversely affect the impartiality of the person having the interest and includes an interest arising from kinship, friendship or membership of an association.

| Item Name   | Item No. | Name              | Type of Interest | Nature of Interest  |
|---|----------|-------------------|------------------|---|
| Proposed Amendment – Co-Operative Bulk Handling, Leeming Road, Grass Valley | 13.3.1   | Cr C R Antonio    | Financial        | Cr Antonio's farming operation holds a \$2 share in CBH.                      |
| Proposed Review of Heritage List  | 13.3.2   | Cr M I Girak      | Proximity        | Cr Girak's residential property is on the proposed Heritage List.             |
| Proposed Review of Heritage List  | 13.3.2   | Cr A J Mencshelyi | Impartiality     | Some owners of properties on the Heritage List are known to Cr Mencshelyi     |
| Proposed Review of Heritage List  | 13.3.2   | Cr R W Tinetti    | Impartiality     | Some owners of properties on the Heritage List are known to Cr Tinetti        |
| Proposed Review of Heritage List  | 13.3.2   | Cr M P Ryan       | Impartiality     | One of the property owners on the proposed Heritage List is known to Cr Ryan. |
| Proposed Review of  | 13.3.2   | Cr D A Hughes     | Impartiality     | One of the property   |

|                                  |        |                   |              |  |
|----------------------------------|--------|-------------------|--------------|--|
| Heritage List                    |        |                   |              | owners on the proposed Heritage List is known to Cr Hughes.                                |
| Proposed Review of Heritage List | 13.3.2 | Cr J E G Williams | Impartiality | Some owners of properties on the Heritage List are known to Cr Williams.                   |
| Proposed Review of Heritage List | 13.3.2 | Cr C R Antonio    | Impartiality | Some owners of properties on the Heritage List are known to Cr Antonio.                    |
| Unauthorised Structure – A72     | 14.2   | Cr J E G Williams | Proximity    | A property Cr Williams co-owns is located across a thoroughfare from the subject property. |



## 5. ANNOUNCEMENT BY THE PRESIDING MEMBER (WITHOUT DISCUSSION)

| <b>Visitations and Consultations</b> |   |
|--------------------------------------|---|
| 21/07/2022                           | CBH Regional Member Forum – Buckland Estate                               |
| 22/07/2022                           | Eclipse Brewery – Wheatbelt Launch - Northam                              |
| 26/07/2022                           | 6PR Radio Interview on loss of bid for the 2022 Air Race                  |
| 26/07/2022                           | Aboriginal Cultural Heritage Workshop - Northam                           |
| 26/07/2022                           | Channel 9 Interview on loss of bid for the 2022 Air Race                  |
| 27/07/2022                           | Triple M News Radio Interview on Ballooning Championship events in 2023   |
| 27/07/2022                           | ABC Radio Interview on Ballooning Championship events in 2023             |
| 28/07/2022                           | Wheatbelt Local Government COVID-19 Information video conference          |
| 29/07/2022                           | ABC Midwest & Wheatbelt Radio Interview on Land Rates                     |
| 01/08/2022                           | Triple M Fortnightly Radio Interview                                      |
| 04/08/2022                           | Northam Liquor Accord Meeting   |
| 04/08/2022                           | Pop Up Shop Official Opening - Northam                                    |
| 05/08/2022                           | Culture and Behaviour Workshop - Online                                   |
| 06/08/2022                           | Lions Community Markets - Northam   |
| 10/08/2022                           | Commonwealth & State Treasury Delegation Dinner - Northam                 |
| 12/08/2022                           | Triple M Fortnightly Radio Interview including commentary on Avon Descent |
| 12/08/2022                           | ABC Midwest & Wheatbelt Morning Show broadcast from Northam               |
| 12/08/2022                           | Bilya Festival - Northam  |
| 13/08/2022                           | Avon Descent – Official Start   |
| 13/08/2022                           | Avon Descent Festival - Toodyay   |
| 14/08/2022                           | Avon Descent – End of race presentations                                  |
| 17/08/2022                           | Tour of Aurizon Rail Yard – Avon Yards - Northam                          |
| <b>Upcoming Events</b>               |   |
| 18/08/2022                           | Regional Capitals Alliance Meeting & Strategic Planning - Perth           |
| 19/08/2022                           | Regional Capitals Alliance Meeting & Strategic Planning - Perth           |
| 20/08/2022                           | Northam Lions Club Changeover Night                                       |
| 23/08/2022                           | Dowerin Field Days Launch - Perth   |
| 24/08/2022                           | Dowerin Field Days – extends for two days                                 |
| 26/08/2022                           | Avon-Midland Zone Meeting – Shire of Victoria Plains                      |
| 29/08/2022                           | Triple M Fortnightly Radio Interview                                      |
| 01/09/2022                           | Local Emergency Management Workshop & Exercise -                          |

|            |  |
|------------|--|
|            | Northam  |
| 03/09/2022 | Lions Community Markets - Northam                    |
| 04/09/2022 | Father's Day   |
| 08/09/2022 | Shire of Northam Strategic Plan Launch and Sundowner |
| 12/09/2022 | Triple M Fortnightly Radio Interview                 |
| 16/09/2022 | Citizenship Ceremony - Northam                       |

### **Operational Matters:**

The Shire has recently published a Youth Survey –the details are as follows:

This survey takes a look at the needs and aspirations of young people living in the Shire of Northam. The survey results will help us to provide better experiences in Northam for young people.

If you're aged between 7 and 18 and live in the Northam Shire, we want to hear from you!

The survey closes 31 August 2022, and can be completed by following this link - <https://app.smartsheet.com/b/form/ab9cc99fe6b24182b32f54a108689e32>

The new waster transfer facility opened its doors on the 1<sup>st</sup> of August. Following public consultation, the name “Northam Re-Store” was chosen. This was, in part, established due to the public wishing to reduce our carbon footprint.

### **Events Calendar**

August is the month when one of our cornerstone events occurs. Starting with the annual Bilya Festival on Friday night and extending to the start of the annual Avon Descent Race on Saturday morning. These events attract many visitors to the Shire, including media outlets, which further increases positive coverage.

The recent announcement of both the National Ballooning Championships in May 2023 and Women's World Ballooning Championships in September 2023 further cement our position as one of, if not the, preeminent Hot Air Ballooning Capital of Australia.

### **Strategic Matters:**

With the Shire of Northam recently finalising the review of the Strategic Community and Corporate Business Plans, there will be an official launch at the start of September. This allows all of residents, ratepayers and the general public to see what, based on consultation, has already occurred, is being undertaken, or has been completed since the review started.

**6. PUBLIC QUESTION TIME**

**6.1 PUBLIC QUESTIONS**

**7. RESPONSE TO PREVIOUS PUBLIC QUESTIONS TAKEN ON NOTICE**

Nil.

**8. RECEIVING OF PETITIONS, PRESENTATIONS AND DEPUTATIONS**

**8.1 PETITIONS**

Nil

**8.2 PRESENTATIONS**

Nil

**8.3 DEPUTATIONS**

Nil

**9. APPLICATION FOR LEAVE OF ABSENCE**

Nil.

**10. CONFIRMATION OF MINUTES**

**10.1 ORDINARY COUNCIL MEETING HELD 20 JULY 2022**

**RECOMMENDATION**

That the minutes of the Ordinary Council meeting held on Wednesday, 20 July 2022 be confirmed as a true and correct record of that meeting.

**10.2 SPECIAL COUNCIL MEETING HELD 27 JULY 2022**

**RECOMMENDATION**

That the minutes of the Special Council meeting held on Wednesday, 27 July 2022 be confirmed as a true and correct record of that meeting.

**10.3 NOTES FROM COUNCIL FORUM MEETING HELD 10 AUGUST 2022**

**RECOMMENDATION**

That Council receive the notes from the Council Forum meeting held Wednesday, 10 August 2022.



## Shire of Northam

### Notes

### Council Forum Meeting

10 August 2022

Council Forum Meeting Notes  
10 August 2022



**DISCLAIMER**

This agenda has yet to be dealt with by the Council. The Recommendations shown at the foot of each item have yet to be considered by the Council and are not to be interpreted as being the position of the Council. The minutes of the meeting held to discuss this agenda should be read to ascertain the decision of the Council.

In certain circumstances members of the public are not entitled to inspect material, which in the opinion of the Chief Executive Officer is confidential, and relates to a meeting or a part of a meeting that is likely to be closed to members of the public.

No responsibility whatsoever is implied or accepted by the Shire of Northam for any act, omission, statement or intimation occurring during Council or Committee meetings.

The Shire of Northam disclaims any liability for any loss whatsoever and howsoever caused arising out of reliance by any person or legal entity on any such act, omission or statement of intimation occurring during Council or Committee meetings.

Any person or legal entity who acts or fails to act in reliance upon any statement, act or omission made in a Council or Committee meeting does so at that person's or legal entity's own risk.

In particular and without derogating in any way from the broad disclaimer above, in any discussion regarding any planning application or application for a licence, any statement or intimation of approval made by any member or Officer of the Shire of Northam during the course of any meeting is not intended to be and is not taken as notice of approval from the Shire of Northam.

The Shire of Northam advises that anyone who has any application lodged with the Shire of Northam must obtain and should only rely on WRITTEN CONFIRMATION of the outcome of the application and any conditions attaching to the decision made by the Shire of Northam in respect of the application.

The Shire of Northam advises that any plans or documents contained within this agenda may be subject to copyright law provisions (*Copyright Act 1968*, as amended) and that the express permission of the copyright owner(s) should be sought prior to their reproduction. It should be noted that copyright owners are entitled to take legal action against any persons who infringe their copyright. A reproduction of material that is protected by copyright may represent a copyright infringement.

Council Forum Meeting Notes  
10 August 2022



**Preface**

When the Chief Executive Officer approves these Notes for distribution they are in essence "informal notes."

At the next Ordinary Meeting of Council the Notes will be received, subject to any amendments made by the Council. The "Received" Notes are then signed off by the Presiding Person.

Please refer to the Ordinary Council meeting agenda and minutes for further information and details in relation to the matters and items discussed at the Forum meeting.

**Unconfirmed Notes**

These notes were approved for distribution on 15 July 2022.

**JASON WHITEAKER**  
**CHIEF EXECUTIVE OFFICER**

**Received Notes**

These notes were received at an Ordinary Meeting of Council held on 20 July 2022.

Signed: .....

*Note: The Presiding Member at the meeting at which the minutes were confirmed is the person who signs above.*

## Contents

|        |   |    |
|--------|---|----|
| 1.     | DECLARATION OF OPENING.....   | 6  |
| 2.     | ACKNOWLEDGEMENT TO COUNTRY.....   | 6  |
| 3.     | ATTENDANCE.....   | 6  |
| 3.1    | APOLOGIES.....  | 6  |
| 3.2    | APPROVED LEAVE OF ABSENCE.....  | 6  |
| 3.3    | ABSENT.....   | 6  |
| 4.     | DISCLOSURE OF INTERESTS.....  | 7  |
| 5.     | ANNOUNCEMENT BY THE PRESIDING MEMBER (WITHOUT DISCUSSION) ...                                   | 9  |
| 6.     | PUBLIC QUESTION TIME.....   | 9  |
| 6.1    | PUBLIC QUESTIONS.....   | 9  |
| 7.     | RESPONSE TO PREVIOUS PUBLIC QUESTIONS TAKEN ON NOTICE.....                                      | 9  |
| 8.     | RECEIVING OF PETITIONS, PRESENTATIONS AND DEPUTATIONS.....                                      | 9  |
| 8.1    | PETITIONS.....  | 9  |
| 8.2    | PRESENTATIONS.....  | 9  |
| 8.3    | DEPUTATIONS.....  | 9  |
| 9.     | APPLICATION FOR LEAVE OF ABSENCE.....   | 9  |
| 10.    | CONFIRMATION OF MINUTES.....  | 9  |
| 10.1   | ORDINARY COUNCIL MEETING HELD 20 JULY 2022.....   | 9  |
| 10.2   | SPECIAL COUNCIL MEETING HELD 27 JULY 2022.....  | 9  |
| 10.3   | NOTES FROM COUNCIL FORUM MEETING HELD 10 AUGUST 2022.....                                       | 9  |
| 11.    | ITEMS BROUGHT FORWARD FOR THE CONVENIENCE OF THOSE IN THE PUBLIC GALLERY.....                   | 10 |
| 12.    | REPORTS OF COMMITTEE MEETINGS.....  | 10 |
| 12.1   | NYOONGAR CULTURAL ADVISORY GROUP COMMITTEE MEETING HELD ON 14 MAY 2022.....                     | 10 |
| 13.    | OFFICER REPORTS.....  | 10 |
| 13.1   | CEO'S Office.....   | 10 |
| 13.1.1 | Lease Agreement for Northam Pistol Club, Portion of Reserve 3303, 98 Clarke Street Northam..... | 10 |
| 13.2   | ENGINEERING SERVICES.....   | 11 |
| 13.2.2 | RFQ 10 of 2022 Spencers Brook Road Spray Seal & Asphalt Works.....                              | 11 |
| 13.3   | DEVELOPMENT SERVICES.....   | 11 |

Council Forum Meeting Notes  
10 August 2022



|        |   |    |
|--------|---|----|
| 13.3.1 | Proposed Amendment – Co-Operative Bulk Handling, Leeming Road, Grass Valley ..... | 11 |
| 13.3.2 | Proposed Review of the Heritage List .....  | 12 |
| 13.4   | CORPORATE SERVICES .....  | 13 |
| 13.4.1 | Accounts & Statements of Accounts 1 July 2022 to 31 July 2022 .....               | 13 |
| 13.5   | COMMUNITY SERVICES .....  | 15 |
| 13.5.1 | Nyoongar Cultural Advisory Group .....  | 15 |
| 14.    | MATTERS BEHIND CLOSED DOORS .....   | 15 |
| 14.1   | LEASE OF A PORTION OF RESERVE 44700 .....   | 15 |
| 14.2   | UNAUTHORISED STRUCTURE – A72 .....  | 16 |
| 15.    | MOTIONS OF WHICH PREVIOUS NOTICE HAS BEEN GIVEN .....                             | 17 |
| 15.1   | FENCED DOG PARK .....   | 17 |
| 16.    | URGENT BUSINESS APPROVED BY DECISION .....  | 17 |
| 17.    | DECLARATION OF CLOSURE .....  | 17 |

UNCONFIRMED



Council Forum Meeting Notes  
10 August 2022



**1. DECLARATION OF OPENING**

The Shire President, Cr C R Antonio declared the meeting open at 5.30pm.

**2. ACKNOWLEDGEMENT TO COUNTRY**

The Shire of Northam would like to acknowledge the Traditional Owners of the land on which we meet, the Ballardong and Whadjuk people of the Nyoongar nation and pay our respects to Elders, past present and emerging.

**3. ATTENDANCE**

**Council:**

Shire President  
Deputy Shire President  
Councillors

C R Antonio  
M P Ryan  
D Galloway  
R W Tinetti  
A J Mencshelyi  
M I Girak  
J E G Williams  
D A Hughes  
H Appleton  
P Curtis

**Staff:**

Chief Executive Officer  
Executive Manager Engineering Services  
Executive Manager Development Services  
Executive Manager Community Services  
Executive Manager Corporate Services  
Acting Governance Officer

J B Whiteaker  
S Patterson  
C B Hunt  
J Metcalf  
C Young  
T P Van Beek

**3.1 APOLOGIES**

Acting Governance Coordinator

A C McCall

**3.2 APPROVED LEAVE OF ABSENCE**

Nil.

**3.3 ABSENT**

Nil.

Council Forum Meeting Notes  
10 August 2022



**4. DISCLOSURE OF INTERESTS**

Members should fill in Disclosure of Interest forms for items in which they have a financial, proximity or impartiality interest and forward these to the Presiding Member before the meeting commences.

As defined in section 5.60A of the Local Government Act 1995, a **financial interest** occurs where a Councillor / Committee Member, or a person with whom the Councillor / Committee Member is closely associated, has a direct or indirect financial interest in the matter. That is, the person stands to make a financial gain or loss from the decision, either now or at some time in the future.

As defined in section 5.61 of the Local Government Act 1995, an **indirect financial interest** includes a reference to a financial relationship between that person and another person who requires a Local Government decision in relation to the matter.

As defined in section 5.60B of the Local Government Act 1995, a person has a **proximity interest** in a matter if the matter concerns a proposed change to a planning scheme affecting land that adjoins the person's land; or a proposed change to the zoning or use of land that adjoins the person's land; or a proposed development (as defined in section 5.63(5)) of land that adjoins the person's land.

As defined in 34C of the Local Government (Administration) Regulations 1996, an **impartiality interest** means an interest that could, or could reasonably be perceived to, adversely affect the impartiality of the person having the interest and includes an interest arising from kinship, friendship or membership of an association.

| Item Name   | Item No. | Name              | Type of Interest | Nature of Interest  |
|---|----------|-------------------|------------------|---|
| Proposed Amendment – Co-Operative Bulk Handling, Leeming Road, Grass Valley | 13.3.1   | Cr C R Antonio    | Financial        | Cr Antonio's farming operation holds a \$2 share in CBH.                  |
| Proposed Review of Heritage List  | 13.3.2   | Cr M I Girak      | Proximity        | Cr Girak's residential property is on the proposed Heritage List.         |
| Proposed Review of Heritage List  | 13.3.2   | Cr A J Mencshelyi | Impartiality     | Some owners of properties on the Heritage List are known to Cr Mencshelyi |
| Proposed Review of Heritage List  | 13.3.2   | Cr R W Tinetti    | Impartiality     | Some owners of properties on the Heritage List are known to Cr Tinetti    |

Council Forum Meeting Notes  
**10 August 2022**



|                                  |        |                   |              |  |
|----------------------------------|--------|-------------------|--------------|--|
| Proposed Review of Heritage List | 13.3.2 | Cr M P Ryan       | Impartiality | One of the property owners on the proposed Heritage List is known to Cr Ryan.              |
| Proposed Review of Heritage List | 13.3.2 | Cr D A Hughes     | Impartiality | One of the property owners on the proposed Heritage List is known to Cr Hughes.            |
| Proposed Review of Heritage List | 13.3.2 | Cr J E G Williams | Impartiality | Some owners of properties on the Heritage List are known to Cr Williams.                   |
| Proposed Review of Heritage List | 13.3.2 | Cr C R Antonio    | Impartiality | Some owners of properties on the Heritage List are known to Cr Antonio.                    |
| Unauthorised Structure – A72     | 14.2   | Cr J E G Williams | Proximity    | A property Cr Williams co-owns is located across a thoroughfare from the subject property. |

UNCONFIRMED

Council Forum Meeting Notes  
10 August 2022



**5. ANNOUNCEMENT BY THE PRESIDING MEMBER (WITHOUT DISCUSSION)**

No queries were raised in relation to these items.

**6. PUBLIC QUESTION TIME**

**6.1 PUBLIC QUESTIONS**

Nil

**7. RESPONSE TO PREVIOUS PUBLIC QUESTIONS TAKEN ON NOTICE**

Nil.

**8. RECEIVING OF PETITIONS, PRESENTATIONS AND DEPUTATIONS**

**8.1 PETITIONS**

Nil

**8.2 PRESENTATIONS**

Nil

**8.3 DEPUTATIONS**

Nil

**9. APPLICATION FOR LEAVE OF ABSENCE**

Nil.

**10. CONFIRMATION OF MINUTES**

**10.1 ORDINARY COUNCIL MEETING HELD 20 JULY 2022**

No queries were raised in relation to this item.

**10.2 SPECIAL COUNCIL MEETING HELD 27 JULY 2022**

Clarification was sought in relation to:

- The total budget allocated to the building of the Shire Depot. The Chief Executive Officer advised of the total budget allocated over the financial years 21/22 and 22/23. The Executive Manager Engineering Services advised that the Depot project was divided into smaller packages, which made it more difficult to accurately calculate the potential cost before commencement. The additional costs are reflective of scoping adjustments and escalating prices.

**10.3 NOTES FROM COUNCIL FORUM MEETING HELD 10 AUGUST 2022**

No queries were raised in relation to this item.

Council Forum Meeting Notes  
10 August 2022



**11. ITEMS BROUGHT FORWARD FOR THE CONVENIENCE OF THOSE IN THE PUBLIC GALLERY**

Nil

**12. REPORTS OF COMMITTEE MEETINGS**

**12.1 NYOONGAR CULTURAL ADVISORY GROUP COMMITTEE MEETING HELD ON 14 MAY 2022**

Clarification was sought in relation to:

- If the meeting minutes from the committee meeting held on 14 MAY 2022 had already been received by council previously. The Chief Executive Officer will seek further clarification prior to council meeting on 17 AUGUST 2022.

Additional Comment

- Staff have confirmed the presented minutes have not been previously provided to Council for endorsement

**13. OFFICER REPORTS**

**13.1 CEO'S Office**

**13.1.1 Lease Agreement for Northam Pistol Club, Portion of Reserve 3303, 98 Clarke Street Northam**

Clarification was sought in relation to:

- How the Pistol Club were able to build a structure without shire approval.  
Executive Manager Development Services advised that the shire simply was not aware that it had been done. However once we became aware, we reached out to the Pistol Club to explain the breach and have been assisting them through the process of retrospective approval since. It was noted that the Pistol Club had not thought they needed approval as they were replacing a shed with a shed (like for a like).
- If there is any liability risk for the shire.  
Chief Executive Officer advised that in his view the exposure would be limited, however it would very much depend on the circumstance. The Shire was simply unaware that the works had been undertaken and as soon as we were made aware of the situation steps were taken to correct it.
- If the Pistol Club would need to follow the same procedure a rate payer would.

Council Forum Meeting Notes  
10 August 2022



Executive Manager Development Services advised that the club would be able to apply for retrospective approval but would still need to comply with all necessary building requirements and specifications.

### 13.2 ENGINEERING SERVICES

#### 13.2.2 RFQ 10 of 2022 Spencers Brook Road Spray Seal & Asphalt Works

Clarification was sought in relation to:

- Why the cost for line marking is estimated as high as it is.  
Executive Manager Engineering Services advised that due to the length of the road plus how many lines will be painted plus the traffic management involved that is the estimated cost.
- If the Shire had previously looked at purchasing a line marking machine themselves.  
Chief Executive Officer advised that that they have purchased a line marking machine for the grass fields but not for roads.

### 13.3 DEVELOPMENT SERVICES

*Cr C R Antonio declared a "Financial" interest in item 13.3.1 – Proposed Amendment – Co-operative Bulk Handling, Leeming Road, Grass Valley as Cr Antonio's farming operation holds a \$2 share in CBH.*

*Cr C R Antonio left the meeting at 5.49pm*

#### 13.3.1 Proposed Amendment – Co-Operative Bulk Handling, Leeming Road, Grass Valley

Clarification was sought in relation to:

- If there was a way to catch the water runoff.  
Executive Manager Development Services advised that CBH addressed this in their drainage management plan.
- If CBH will assist to fix roads damaged by heavy truck loads.  
Executive Manager Development Services advised that this is covered by condition 3 in the officer recommendation.

*Cr C R Antonio returned to the meeting at 5.51pm*

*Cr M I Girak declared a "Proximity" interest in item 13.3.2 – Proposed Review of the Heritage List as Cr Girak's residential property is on the proposed Heritage List.*

Council Forum Meeting Notes  
10 August 2022



Cr A J Mencshelyi declared a "Impartiality" interest in item 13.3.2 – Proposed Review of the Heritage List as some property owners on the proposed Heritage List are known to Cr Mencshelyi.

Cr R W Tinetti declared a "Impartiality" interest in item 13.3.2 – Proposed Review of the Heritage List as some property owners on the proposed Heritage List are known to Cr Tinetti.

Cr M P Ryan declared a "Impartiality" interest in item 13.3.2 – Proposed Review of the Heritage List as one of the property owners on the proposed Heritage List are known to Cr Ryan.

Cr D A Hughes declared a "Impartiality" interest in item 13.3.2 – Proposed Review of the Heritage List as one of the property owners on the proposed Heritage List are known to Cr Hughes.

Cr J E G Williams declared a "Impartiality" interest in item 13.3.2 – Proposed Review of the Heritage List as some property owners on the proposed Heritage List are known to Cr Williams.

Cr C R Antonio declared a "Impartiality" interest in item 13.3.2 – Proposed Review of the Heritage List as some property owners on the proposed Heritage List are known to Cr Antonio.

Cr M I Girak left the meeting at 5.52pm

### 13.3.2 Proposed Review of the Heritage List

Clarification was sought in relation to:

- If the list provided includes all properties on the previous Heritage List. Executive Manager Development Services advised that the list shows the original properties plus the properties being recommended for addition.
- If the different wording in attachments on pages 128-129 will cause issues in future. Executive Manager Development Services advised that there will be no issues.
- If Dempster Home at Muresk Institute will need to come through the shire or if it is exempt due to being on government property. Executive Manager Development Services advised that Dempster Home would generally be exempt from the Shire of Northam approval process as it is State Government owned but would still be required to go through the internal government heritage process.
- If the Centenary Hill monument is included on the Heritage List. Executive Manager Development Services advised his understanding is that it is not currently included on the Municipal Heritage Inventory (MHI) (soon to be renamed Local Heritage Survey), however could be considered in the future.

Council Forum Meeting Notes  
10 August 2022



- If Pool Street bridge is included on to the Heritage list will this mean that the Shire is liable/obligated to fix the disrepair on the bridge. Executive Manager Development Services advised that as the Shire does not own the bridge, we will not be liable for the repair. However, having the bridge listed in the Heritage list may strengthen a case to obtain funding for recommissioning/repair.
- Will the Shire respond to the 5 submissions received regarding the Heritage list. Executive Manager Development Services advised that the Shire will respond to the submissions.

Cr M I Girak returns to the meeting at 6.02pm

### 13.4 CORPORATE SERVICES

#### 13.4.1 Accounts & Statements of Accounts 1 July 2022 to 31 July 2022

Clarification was sought in relation to:

- Clarification around payment for crash barriers on Mitchell Avenue and whether it actually belongs to the Shire or Main Roads. Executive Manager Engineering Services advised that Mitchell Ave belongs to the Shire, however that the project to fix the road has been 2/3 funded by Main Roads.
- Why the finance report was not provided in this agenda. Executive Manager Corporate Services advised that due to the heavy workload at this time of year the report was not ready as yet but will be provided in next month's agenda.



Council Forum Meeting Notes  
10 August 2022



| Reference     | Page # | Details Reference             | Question  | Query By    | Answer  | Answered By |
|---------------|--------|-------------------------------|---|-------------|---|-------------|
| EFT44357      | 185    | Mad Dog Promo Key Rings       | What are these for  | Cr Tinetti  | As per Community Safety Committee meeting motion 090, purchased key rings with community safety messages on them to distribute to members of the Community  | Jaime       |
| EFT44417      | 196    | Grafton Electrics             | Why so much   | Cr Tinetti  | This was to repair 21 lights on Minson Avenue that were not working, including five that needed replaced, (broken presumed by slingshot), an elevated platform was required to perform the works. Broken bulbs were replaced with LED bulbs | Shane       |
| EFT44295      | 175    | Macri Partners                | Financial management review 21/22 - \$19800.00- is this for part of the normal audit process?                           | Cr Williams | Yes, this is required to be carried out under the Local Government Financial Management Regulations 1996 every three financial years, results will be presented to Council via the Audit Committee on the 25 August 2022                    | Colin       |
| EFT44408      | 195    | Country Comfort style Northam | Enterprise office chair - \$948.00- is this for one chair only? Is there a maximum set for expenditure on staff chairs? | Cr Williams | This was for 3 office chairs, no maximum price is set for expenditure on office chairs, though in general they cost between \$300-\$400 each. The greater the weight rating the more expensive the chair as a general rule.                 | Colin       |
| EFT44439      | 199    | Promopal Pty Ltd              | Umbrella canopies for Bilya Festival - \$6377.80- is this for purchase or hire?   | Cr Williams | Purchased for use at Bilya Festival, it is noted that the purchase of the umbrellas was less than hiring a marquee for the event.   | Jo          |
| EFT44449      | 201    | The Book Shed                 | Paint lettering onto concrete at Bernard Park - \$1309.00- for what?  | Cr Williams | This was for the words, River Heart Land painted on the footpath out the front of the BKB as part of initiatives to attract people into the centre.   | Jo          |
| CEO C/card    | 211    | N/a                           | Confirming the personal purchase of \$500.00 has been refunded?   | Cr Williams | The request has been made for the refund, as yet still pending but should be deposited this month.  | Colin       |
| EMCOMS C/card | 212    | Harvey Norman                 | Cricut cutting machine and tools for \$468.00- purchased for what please?   | Cr Williams | Purchased by the events team to be used at events in general, it was initially used to cut the leaves for the reconciliation tree, other potential uses are signage/labelling etc.  | Jo          |

## 13.5 COMMUNITY SERVICES

### 13.5.1 Nyoongar Cultural Advisory Group

Clarification was sought in relation to:

- The use of the meeting room at the Bilya Koort Boodja and adding a requirement for a welcome to country.  
Chief Executive Officer advised that the hope is that while any one can use the room, they will still leave the centre with more of an understanding of the indigenous culture.
- Would a person hiring the room have to pay someone to do a welcome to country.  
Chief Executive Officer advised that they would be able to do an acknowledgement to country at no cost.

## 14. MATTERS BEHIND CLOSED DOORS

### RECOMMENDATION

Minute No: C.4525

Moved: Cr Ryan

Seconded: Cr Hughes

That Council, in accordance with section 11.1(i) of the Shire of Northam Standing Orders Local Law 2018 and Section 5.23 (2) (b) (c) (d) of the Local Government Act 1995 meet behind closed doors to consider agenda items:

- 14.1 Lease of a portion of Reserve 44700 - as the matter relates to a contract which may be entered into.
- 14.2 Unauthorised Structure – A72 – as the matter relates to the personal affairs of a person and legal advice obtained or which may be obtained.

CARRIED 10/0

### 14.1 LEASE OF A PORTION OF RESERVE 44700

Clarification was sought in relation to:

- If the area is larger but the rates stay the same.  
Chief Executive Officer advised that there will be no monetary change to the lease.

*Cr J E G Williams declared a "Proximity" interest in item 14.2 – Unauthorised Structure – A72 as a property that Cr Williams co-owns is located directly across a thoroughfare from the subject property.*

Council Forum Meeting Notes  
10 August 2022



Cr J E G Williams left the meeting at 6.10pm

#### 14.2 UNAUTHORISED STRUCTURE – A72

Clarification was sought in relation to:

- If this individual completed the correct application process and had an engineer sign off on the structure in question, would it be allowed. Executive Manager Development Services clarified that the structure would need to meet all requirements and specifications of both building and planning departments.
- If it is possible that the individual needs assistance through the process. Executive Manager Development Services advised that this situation has been ongoing for 4 years and all reasonable assistance has been offered to the individual.
- If the structure was relocated to a rural property would that remove the issue. Executive Manager Development Services advised that this could address the planning issue but not building code matters unless the structure was used as a non-habitable building or significantly altered.
- Should the Shire consider the inclusion of a flyer with the rates with information for rate payers regarding not building without a permit. Chief Executive Officer advised that as the number of issues in Northam are relatively minor, it is not considered to be a significant enough matter to warrant more information to accompany the rate notice, however some promotion could occur through other means.
- Could this building be classified as a Granny Flat. Executive Manager Development Services advised that even if it was, granny flats are still subject to the same building requirements as a habitable dwelling. As these buildings are becoming more popular, how do the shire plan to address it.
- Executive Manager Development Services advised that there are a number of companies that applied and been approved to build small modular buildings that comply with Shire specifications. Council has an existing policy in place with respect to Transportable buildings and provided they comply with that policy approvals can be issued.

Colin Young left the meeting at 6.20pm

Colin Young returned to the meeting at 6.23pm

Council Forum Meeting Notes  
10 August 2022



Cr J E G Williams returned to the meeting at 6.36pm

| <b>RECOMMENDATION / COUNCIL DECISION</b>               |                      |
|--|----------------------|
| <b>Minute No:</b>                                      | <b>C. 4526</b>       |
| <b>Moved:</b>  | <b>Cr Mencshelyi</b> |
| <b>Seconded:</b>                                       | <b>Cr Ryan</b>       |
| <b>That Council move out from behind closed doors.</b> |                      |
| <b>CARRIED 10/0</b>                                    |                      |

**15. MOTIONS OF WHICH PREVIOUS NOTICE HAS BEEN GIVEN**

**15.1 FENCED DOG PARK**

Clarification was sought in relation to:

- Would the petition be accepted with the majority of the signers not being located in Northam.  
Chief Executive Officer advised that this document would not be recognised as a formal petition as it does not comply with the requirements under the Shire of Northam Standing Order local law. The proponent was advised of this.
- Is a fenced dog park part of any identified future plans of the Shire.  
Executive Managed Development Services advised that it is not currently in a recognised plan, but discussions have been held previously.

**16. URGENT BUSINESS APPROVED BY DECISION**

Nil.

**17. DECLARATION OF CLOSURE**

The Shire President, Cr C R Antonio declared the meeting closed at 6.40pm.

**11. ITEMS BROUGHT FORWARD FOR THE CONVENIENCE OF THOSE IN THE PUBLIC GALLERY**

Nil

**12. REPORTS OF COMMITTEE MEETINGS**

**12.1 NYOONGAR CULTURAL ADVISORY GROUP COMMITTEE MEETING HELD ON 14 MAY 2022**

**Receipt of Minutes:**

**RECOMMENDATION**

**That Council receive the minutes from the Nyoongar Cultural Advisory Group Committee meeting held on 14 May 2022.**

**Adoption of Recommendations:**

**RECOMMENDATION**

**That Council:**

- 1. Accepts the following nominations on the Nyoongar Cultural Advisory Group Committee:**
  - Ms Donna Moody – representing the Moody Family
  - Yvonne Kickett – representing the Kickett Family
  - Shirley Slater – representing the Slater Family
- 2. Receives the Bilya Koort Boodja update as presented.**
- 3. Accepts the plan to host an event or events for the week of Reconciliation Week, 27 May 2022 – 3 June 2022.**

Note: This committee was disbanded on 22 July 2022 and replaced with a working group.

**Attachment 1 – Nyoongar Cultural Advisory Group Meeting Minutes 4 May 2022**



Shire of Northam  
*Heritage, Commerce and Lifestyle*

**Shire of Northam**

**Agenda**

**Nyoongar Cultural Advisory**

**Group Meeting**

**4 May 2022**



Nyoongar Cultural Advisory Group Committee Minutes  
04 May 2022



### DISCLAIMER

These minutes are yet to be dealt with by the Council. The Recommendations shown at the foot of each item have yet to be considered by the Council and are not to be interpreted as being the position of the Council. The minutes of the meeting held to discuss this agenda should be read to ascertain the decision of the Council.

In certain circumstances members of the public are not entitled to inspect material, which in the opinion of the Chief Executive Officer is confidential, and relates to a meeting or a part of a meeting that is likely to be closed to members of the public.

No responsibility whatsoever is implied or accepted by the Shire of Northam for any act, omission, statement or intimation occurring during Council or Committee meetings.

The Shire of Northam disclaims any liability for any loss whatsoever and howsoever caused arising out of reliance by any person or legal entity on any such act, omission or statement of intimation occurring during Council or Committee meetings.

Any person or legal entity who acts or fails to act in reliance upon any statement, act or omission made in a Council or Committee meeting does so at that person's or legal entity's own risk.

In particular and without derogating in any way from the broad disclaimer above, in any discussion regarding any planning application or application for a licence, any statement or intimation of approval made by any member or Officer of the Shire of Northam during the course of any meeting is not intended to be and is not taken as notice of approval from the Shire of Northam.

The Shire of Northam advises that anyone who has any application lodged with the Shire of Northam must obtain and should only rely on **WRITTEN CONFIRMATION** of the outcome of the application and any conditions attaching to the decision made by the Shire of Northam in respect of the application.

The Shire of Northam advises that any plans or documents contained within this agenda may be subject to copyright law provisions (*Copyright Act 1968*, as amended) and that the express permission of the copyright owner(s) should be sought prior to their reproduction. It should be noted that copyright owners are entitled to take legal action against any persons who infringe their copyright. A reproduction of material that is protected by copyright may represent a copyright infringement.

## Contents

|     |   |    |
|-----|---|----|
| 1.  | DECLARATION OF OPENING.....   | 4  |
| 2.  | ACKNOWLEDGEMENT TO COUNTRY.....   | 4  |
| 3.  | ATTENDANCE.....   | 4  |
|     | 3.1 APOLOGIES.....  | 4  |
|     | 3.2 APPROVED LEAVE OF ABSENCE.....  | 5  |
|     | 3.3 ABSENT.....   | 5  |
| 4.  | DISCLOSURE OF INTERESTS.....  | 5  |
| 5.  | RECEIVING OF PETITIONS, PRESENTATIONS AND DEPUTATIONS.....  | 5  |
| 6.  | CONFIRMATION OF MINUTES.....  | 7  |
|     | 6.1 COMMITTEE MEETING HELD ON 6 APRIL 2022.....   | 7  |
| 7.  | COMMITTEE REPORTS.....  | 7  |
|     | 7.2 NOMINATION MEMBERSHIP ON THE NYOONGAR CULTURAL<br>ADVISORY GROUP COMMITTEE – DONNA MOODY..... | 7  |
|     | 7.1 BILYA KOORT BOODJA UPDATE.....  | 10 |
|     | 7.5 PLANNING FOR NATIONAL RECONCILIATION WEEK EVENT 27 MAY –<br>3 JUNE 2022.....                  | 14 |
|     | 7.3 TRACKS & TRAILS MASTER PLAN CONSULTATION.....   | 19 |
|     | 7.4 CULTURAL AWARENESS VIDEO.....   | 24 |
|     | 7.6 REVIEW OF THE TERMS OF REFERENCE FOR THE NYOONGAR<br>CULTURAL ADVISORY GROUP.....             | 26 |
| 8.  | URGENT BUSINESS APPROVED BY DECISION.....   | 31 |
| 9.  | DATE OF NEXT MEETING.....   | 31 |
| 10. | DECLARATION OF CLOSURE.....   | 31 |



Nyoongar Cultural Advisory Group Committee Minutes  
04 May 2022



### 1. DECLARATION OF OPENING

The Chairperson Cr Michael Ryan declared the meeting open at 3.35pm

### 2. ACKNOWLEDGEMENT TO COUNTRY

The Shire of Northam would like to acknowledge the Traditional Owners of the land on which we meet, the Ballardong people of the Nyoongar nation and pay our respects to Elders, past present and emerging.

- Cr Michael Ryan gave an Acknowledgement of Country, followed by a Welcome to Country by Mrs Deborah Moody. It was noted that if an Elder is present, they should be give the Welcome to Country.

### 3. ATTENDANCE

#### Committee:

Councillors

Moody Family  
McGuire Family  
Davis Family

ATSI Representative  
Stack Family

M P Ryan  
A J Mencshelyi  
Julie Wynne  
Deborah Moody  
Jermaine Davis (left the meeting 5:00pm)  
Brenda DeAtta  
Elizabeth Stack (arrived 4:29pm)

#### Staff:

CEO  
Exec. Manager Community Services  
Community Development Officer  
Manager Communications & Tourism

Jason Whiteaker  
Jo Metcalf  
Jaime Hawkins  
Vic Williams

#### Guests:

Donna Moody  
Boyd Kickett  
Yvonne Kickett  
Shirley Slater

#### 3.1 APOLOGIES

BKB Centre Coordinator  
Ryder Family  
Davis Family

Robyn Davis  
Vivienne Ryder  
Kathy Davis

Nyoongar Cultural Advisory Group Committee Minutes  
04 May 2022



**3.2 APPROVED LEAVE OF ABSENCE**

Nil.

**3.3 ABSENT**

Ryder Family  
Moody Family  
Garlett Family  
Stack Family  
McGuire Family

Joan Parfitt  
Priscilla Moody  
Kirk Garlett  
Kate Stack  
Maria Nickels

**4. DISCLOSURE OF INTERESTS**

Nil.

**5. RECEIVING OF PETITIONS, PRESENTATIONS AND DEPUTATIONS**

**5.1 JASON WHITEAKER - INDUCTION COMMITTEE OF COUNCIL**

**DISCUSSION**

- Ms Donna Moody requested the structure & process of meeting be considered. The meeting held 6 April the agenda was rushed through, and Elders were not given adequate time for consideration. It was agreed that the presentations at the previous meeting were time consuming and these be limited in the future.
- Ms Donna Moody questioned whether there was to be the opportunity for the Elders to take ownership of the Committee. CEO, Jason Whiteaker explained the position of the NCAG as a formal Committee of Council established under the Local Government Act. How the committee is run is governed by the Act. The Elders cannot take ownership of the Committee but can take leadership roles. Being a Committee of Council, the Elders are given a strong voice on cultural matters and decisions made are reported directly back to Council and are to be actioned.
- Mrs Deborah Moody asked why the committee are not receiving sitting fees. Mr Jason Whiteaker explained that the Local Government Act precluded the Shire from paying people to sit on Committees of Council. Ms Shirley Slater asked if this is something that Council can change their policy on, in which Mr Whiteaker explained that it is State Government legislation, and the Shire of Northam Council has no power to change it and must follow the legislation.

Nyoongar Cultural Advisory Group Committee Minutes  
04 May 2022



Mr Whiteaker stated that he hoped the Committee would see the bigger picture beyond the issue of payment for meeting attendance and leave a legacy for future generations by ensuring Council is celebrating Aboriginal Culture and capturing cultural knowledge for the community so this is not lost. Guidance is provided by the committee, however stories are collected outside the operations of the Committee and individuals are paid for their time when recording stories and knowledge.

Ms Donna Moody requested that the CEO, Jason Whiteaker investigates ways the Committee could be restructured so Elders and the Aboriginal Community can benefit from payment of their personal time and knowledge. Mr Whiteaker stated that Council could look at the NCAG becoming an informal group, who would then be eligible to receive payment, but in doing this the Committee would lose its strength of having a direct line to Council, where decisions made at NCAG meetings are reported to Council for implementation.

Mr Jermaine Davis stated that when invited to nominate, it was clearly raised to him that it was not to be a paid position to sit on the NCAG, that it was to be a voluntary role. He suggested that each Elder could be contacted to raise and communicate issues and concerns to be discussed at the meeting rather than getting a set agenda they have no input into. Mr Whiteaker agreed that 10 minutes could be dedicated to the start or conclusion of the meeting for Elders to raise topics and issues for discussion.

The Council Committee meeting Code of Conduct was distributed to committee.

\*Ms Elizabeth Stack entered the meeting at 4:29pm.

Nyoongar Cultural Advisory Group Committee Minutes  
04 May 2022



## 6. CONFIRMATION OF MINUTES

### 6.1 COMMITTEE MEETING HELD ON 6 APRIL 2022

#### RECOMMENDATION / COUNCIL DECISION

Minute No: NCAG. 31  
Moved: Ms Julie Wynne  
Seconded: Cr Attila Mencshelyi

That the minutes of the Nyoongar Cultural Advisory Group meeting held on 6 April 2022 be confirmed as a true and correct record of that meeting, subject to the correction of the spelling of Cr. Attila Mencshelyi on page 16.

CARRIED 7/0

## 7. COMMITTEE REPORTS

Agenda item 7.2 was brought forward.

### 7.2 NOMINATION MEMBERSHIP ON THE NYOONGAR CULTURAL ADVISORY GROUP COMMITTEE – DONNA MOODY

|                                  |  |
|----------------------------------|--|
| File Reference:                  | 2.1.3.7  |
| Reporting Officer:               | Jaime Hawkins, Community Development Officer     |
| Responsible Officer:             | Jo Metcalf, Executive Manager Community Services |
| Officer Declaration of Interest: | Nil  |
| Voting Requirement:              | Simple Majority                                  |
| Press release to be issued:      | Nil  |

#### BRIEF

For the Committee to accept the nomination of Donna Moody on to the Nyoongar Cultural Advisory Committee to represent the Moody Family.

ATTACHMENTS Nil

#### A. BACKGROUND / DETAILS

Nyoongar Cultural Advisory Group Committee Minutes  
04 May 2022



Ms Donna Moody was previously endorsed as a member of the Nyoongar Cultural Advisory Group in 2019, however was unable to attend meetings. Following her attendance at the meeting held 6 April 2022, Ms Moody submitted a nomination form to join the Committee representing the Moody Family on behalf of her father who is a Moody Elder.

The Moody Family also have Mrs Julie Wynne and Ms Priscilla Moody as current representatives. Only one family representative is eligible to vote, other members can be nominated as Proxy members and attendance at meetings is open to the public.

**B. CONSIDERATIONS**

**B.1 Strategic Community / Corporate Business Plan**

Theme Area 4: Environment and Heritage  
Outcome 4.2: Northam honours, and is recognised for, its unique heritage and cultural identity  
Objective: There is a strong, respected and valued Aboriginal community and culture in the Shire of Northam

**B.2 Financial / Resource Implications**

Nil.

**B.3 Legislative Compliance**

Nil.

**B.4 Policy Implications**

Nil.

**B.5 Stakeholder Engagement / Consultation**

Calls for Expressions of Interest to join the Committee were advertised via social media and the Shire website.

**B.6 Risk Implications**

| Risk Category   | Description   | Rating<br>(likelihood x consequence) | Mitigation Action  |
|-----------------|---|--------------------------------------|--|
| Financial       | N/A   |                                      |  |
| Health & Safety | N/A   |                                      |  |
| Reputation      | Membership on the committee is not seen as representative of the Northam Ballardong Nyoongar Community. | Unlikely(2) x Minor(2) = Low (4)     | Shire develops Terms of Reference and appoints representation in consultation with Ballardong Nyoongar Elders. |

Nyoongar Cultural Advisory Group Committee Minutes  
**04 May 2022**



|                      |     |  |  |
|----------------------|-----|--|--|
| Service Interruption | N/A |  |  |
| Compliance           | N/A |  |  |
| Property             | N/A |  |  |
| Environment          | N/A |  |  |

**C. OFFICER'S COMMENT**

The Committee are to be given the opportunity to consider the nomination received from Ms Donna Moody as a representative of the Moody Family.

**DISCUSSION**

Further nominations received at the meeting from Mrs Yvonne Kickett and Ms Shirley Slater.

**RECOMMENDATION**

**That Council accepts the nomination of Ms Donna Moody, on the Nyoongar Cultural Advisory Group Committee.**

**RECOMMENDATION / COUNCIL DECISION**

Minute No: **NCAG. 33**  
 Moved: **Cr Michael Ryan**  
 Seconded: **Mrs Deborah Moody**

**That Council accepts the following nominations on the Nyoongar Cultural Advisory Group Committee:**

- **Ms Donna Moody – representing the Moody Family**
- **Yvonne Kickett – representing the Kickett Family**
- **Shirley Slater – representing the Slater Family**

**CARRIED 7/0**

Nyoongar Cultural Advisory Group Committee Minutes  
04 May 2022



**7.1 BILYA KOORT BOODJA UPDATE**

|   |  |
|---|--|
| <b>File Reference:</b>                  | 1.3.13.5   |
| <b>Reporting Officer:</b>               | Robyn Davis, BKB Coordinator                     |
| <b>Responsible Officer:</b>             | Jo Metcalf, Executive Manager Community Services |
| <b>Officer Declaration of Interest:</b> | Nil.   |
| <b>Voting Requirement:</b>              | Simple Majority                                  |
| <b>Press release to be issued:</b>      | Nil.   |

**BRIEF**

For the Committee to receive an update on the Bilya Koort Boodja Centre.

**ATTACHMENTS**

Nil.

**A. BACKGROUND / DETAILS**

The Bilya Koort Boodja is the Aboriginal Interpretive Centre in the Shire of Northam, offering visitors a visual and immersive experience into Aboriginal culture, heritage and traditions through various displays and events.

**A.1 Visitor Numbers**

| Month    | BKB visitations - Normal | BKB visitations - Free Pass | BKB visitations - Concessions | BKB visitations - Average per day | BKB Entry Fees |
|----------|--------------------------|-----------------------------|-------------------------------|-----------------------------------|----------------|
| APRIL 21 | 200                      | 1                           | 122                           | 10.76                             | \$2610.00      |
| MAY 21   | 149                      | 0                           | 111                           | 8.38                              | \$2045.00      |
| JUNE 21  | 161                      | 0                           | 96                            | 8.56                              | \$2090.10      |
| JULY 21  | 182                      | 0                           | 129                           | 10.03                             | \$2465         |
| AUG 21   | 199                      | 1                           | 121                           | 10.32                             | \$2595         |
| SEPT 21  | 251                      | 0                           | 126                           | 12.56                             | \$3140         |
| OCT 21   | 233                      | 4                           | 180                           | 13.32                             | \$3230         |
| NOV 21   | 126                      | 0                           | 78                            | 6.8                               | \$1650         |
| DEC 21   | 105                      | 0                           | 134                           | 7.70                              | \$1720         |

| Month | BKB visitations - | BKB visitations - | BKB visitations | BKB visitations - | BKB Entry Fees |
|-------|-------------------|-------------------|-----------------|-------------------|----------------|
|       |                   |                   |                 |                   |                |

Nyoongar Cultural Advisory Group Committee Minutes  
04 May 2022



|                 | Single Entry | Annual Membership | – Free Pass | Average per day |       |
|-----------------|--------------|-------------------|-------------|-----------------|-------|
| JAN 22          | 176          | 2                 | 0           | 5.74            | \$920 |
| FEB 22          | 47           | 0                 | 2           | 1.75            | \$235 |
| MARCH 22        | 195          | 2                 | 0           | 6.35            | \$985 |
| APRIL – TO DATE | 327          | 0                 | 0           | 10.90           | \$480 |

**A.2 Programmed Activities**

Upcoming Programs;

NAIDOC

Ms Robyn Davis will provide an update on planned activities for the Bilya Koort Boodja Centre.

**A.3 Marketing**

An update to be provided by Ms Jo Metcalf.

**B. CONSIDERATIONS**

**B.1 Strategic Community / Corporate Business Plan**

Theme Area 4:

Environment and Heritage.

Outcome 4.2:

Northam honours, and is recognised for, its unique heritage and cultural identity.

Objective:

There is a strong, respected and valued Aboriginal community and culture in the Shire of Northam.

**B.2 Financial / Resource Implications**

Nil.

**B.3 Legislative Compliance**

Nil.

**B.4 Policy Implications**

Nil.

**B.5 Stakeholder Engagement / Consultation**

Nil.

**B.6 Risk Implications**

| Risk Category | Description | Rating (likelihood x | Mitigation Action |
|---------------|-------------|----------------------|-------------------|
|---------------|-------------|----------------------|-------------------|



Nyoongar Cultural Advisory Group Committee Minutes  
04 May 2022



|                      |  | consequence                           |  |
|----------------------|--|---------------------------------------|--|
| Financial            | The Centre fails to reach financial sustainability                     | Possible (3) x Medium (3)= 9 (Medium) | Development of marketing plan to promote centre<br><br>Secure external funding |
| Health & Safety      | N/A  |                                       |  |
| Reputation           | The Centre fails to provide an experience that delivers on expectation | Possible (3) x Medium (3)= 9 (Medium) | Ensure weekend activities are in place   |
| Service Interruption | N/A  |                                       |  |
| Compliance           | N/A  |                                       |  |
| Property             | N/A  |                                       |  |
| Environment          | N/A  |                                       |  |

### C. OFFICER'S COMMENT

Tourism Australia brief – Wanting to do some filming on 9<sup>th</sup> May to promote the BKB experience. Looking for Talent to be involved in the project.

Thylacine update – Collection of stories.

### DISCUSSION

An update was provided by the Executive Manager Community Services, Ms Jo Metcalf.

- The Northam Yorga's Group are now meeting at the BKB.
- Tourism WA will be doing a photo shoot on the 9<sup>th</sup> May and the TV show Getaway will be featuring the BKB in a piece on the Avon Valley.

Mrs Victoria Williams gave an update on Stage 2 of the BKB.

- The Shire has funding for upgrades and repairs for existing things within the centre.
- The graphic as you enter the exhibition is to be changed.
- There will be new installations in the Welcome Space to give the impression of trees and new lighting effects.
- Some of the graphics of the wall panels are to be re-done, including the first panel where feedback has been that writing is too small.
- New stories will be collected from those who are yet to be captured, both written and video.

Nyoongar Cultural Advisory Group Committee Minutes  
04 May 2022



- Glitches to the touch screen will be repaired, so that all of the content doesn't pop up on the screen at once.
- Season monitors will be re-programmed and fitted with new speakers.
- The lighting will be improved to highlight the names on the wooden beams in the sorry space, as they are barely visible at the moment.
- Speakers will be upgraded to include directional speakers, as the sounds are currently competing with each other.
- There will be new showcases installed in the shop area for the stock. These will also be designed to provide better theft prevention.
- A digital screen will be installed out the front of the centre to highlight the exhibition and give people a glimpse of what they are paying for if they come in.

Ms Shirley Slater asked if the stories of the Ballardong soldiers be included in the updates to the exhibition, as she believes this will provide greater interest for the schools. Mrs Victoria Williams said that these could be programmed in to feature seasonally around ANZAC Day and Remembrance Day.

Ms Jo Metcalf updated the Committee that the BKB Centre Coordinator, Ms Robyn Davis has resigned. She will be finishing on 17 May 2022. Mr Jason Whiteaker, advised that an Elder is to sit on the interview panel for the selection of the new BKB Centre Coordinator. Mrs Yvonne Kickett recommended that Mrs Kathy Davis and Mrs Deborah Moody are the best Elders to be on the selection panel for the recruitment of the new Coordinator.

Ms Jo Metcalf provided an update on the Community Arts Network Noongar Lullabies Project. Session one was very successful, and on Friday 6 May ABC TV will be filming for national TV for a program on arts programs and community wellbeing. Ms Metcalf encouraged the committee to attend and advise others in the community to attend. It was suggested by Ms Donna Moody that Clontarf Academy and the Wirrpanda Girls be contacted to see if they are able to attend.

Nyoongar Cultural Advisory Group Committee Minutes  
04 May 2022



**RECOMMENDATION / COUNCIL DECISION**

**Minute No:** NCAG. 32

**Moved:** Mrs Deborah Moody

**Seconded:** Ms Shirley Slater

**That Council receives the Bilya Koort Boodja update as presented.**

**CARRIED 7/0**

\*Mr Jermaine Davis left the meeting at 5:00pm.

Agenda item 7.5 was brought forward.

**7.5 PLANNING FOR NATIONAL RECONCILIATION WEEK EVENT 27 MAY – 3 JUNE 2022**

|   |  |
|---|--|
| <b>File Reference:</b>                  | 2.1.3.7  |
| <b>Reporting Officer:</b>               | Jaime Hawkins, Community Development Officer     |
| <b>Responsible Officer:</b>             | Jo Metcalf, Executive Manager Community Services |
| <b>Officer Declaration of Interest:</b> | Nil  |
| <b>Voting Requirement:</b>              | Simple Majority                                  |
| <b>Press release to be issued:</b>      | Nil  |

**BRIEF**

National Reconciliation Week (NRW) is a time for all Australians to learn about our shared histories, cultures, and achievements, and to explore how each of us can contribute to achieving reconciliation in Australia. National Reconciliation Week is from 27<sup>th</sup> May to the 3<sup>rd</sup> June. These dates commemorate two significant milestones in the reconciliation journey— the successful 1967 referendum, and the High Court Mabo decision respectively. The theme for Reconciliation Week 2022 is "Be Brave. Make Change"

**ATTACHMENTS**

Attachment 4: National Reconciliation Week Poster 2022

**A. BACKGROUND / DETAILS**

Nyoongar Cultural Advisory Group Committee Minutes  
04 May 2022



Since 2018 the Shire of Northam has hosted community National Reconciliation Week events, with the exception of 2020 where Covid restrictions meant that a community gathering could not take place, so the event was recognised online.

The National Reconciliation Week 2022 theme, "Be Brave. Make Change." is a challenge to all Australians— individuals, families, communities, organisations and government—to Be Brave and tackle the unfinished business of reconciliation so we can Make Change for the benefit of all Australians.

This year Reconciliation Australia are asking everyone to make change beginning with brave actions in their daily lives – where they live, work, play and socialise.

National Reconciliation Week—27 May to 3 June—is a time for all Australians to learn about our shared histories, cultures, and achievements, and to explore how each of us can contribute to achieving reconciliation in Australia.

<https://nrw.reconciliation.org.au>

**B. CONSIDERATIONS**

**B.1 Strategic Community / Corporate Business Plan**

Theme Area 4: Environment and Heritage  
Outcome 4.2: Northam honours, and is recognised for, its unique heritage and cultural identity  
Objective: There is a strong, respected and valued Aboriginal community and culture in the Shire of Northam

**B.2 Financial / Resource Implications**

There is a small financial and resource implication to undertake activities relating to Reconciliation Week.

**B.3 Legislative Compliance**

Nil.

**B.4 Policy Implications**

Nil.

**B.5 Stakeholder Engagement / Consultation**

The previous RAP Working Group are being consulted about planning a NRW event.

**B.6 Risk Implications**

| Risk Category | Description | Rating<br>(likelihood x<br>consequence) | Mitigation Action |
|---------------|-------------|---|-------------------|
|               |             |   |                   |

Nyoongar Cultural Advisory Group Committee Minutes  
04 May 2022



|                      |  |                                  |   |
|----------------------|--|----------------------------------|---|
| Financial            |  |                                  |   |
| Health & Safety      | N/A  |                                  |   |
| Reputation           | Shire of Northam is seen as not supportive of reconciliation | Unlikely(2) x Minor(2) = Low (4) | Shire develops RAP in consultation with RAP Working group and endorsement of Reconciliation Australia |
| Service Interruption | N/A  |                                  |   |
| Compliance           | N/A  |                                  |   |
| Property             | N/A  |                                  |   |
| Environment          | N/A  |                                  |   |

**C. OFFICER'S COMMENT**

To commemorate National Reconciliation Week 2022, it is proposed that the Shire of Northam in conjunction with the Nyoongar Cultural Advisory Group host a celebration on Friday 27 May 2022 at the Bilya Koort Boodja Centre. The event will include:

- Welcome to Country.
- Official address by the Shire President or Chairperson of the NCAG and representatives.
- Kangaroo stew and damper for morning tea or lunch for invited guests and community, including NCAG members, Elders, Shire of Northam Councillors and staff, local parliamentary representatives, Northam Police, government agencies and local businesses.
- Growing of the BKB Reconciliation Tree with individuals to place a new leaf on the tree with a message of reconciliation.
- Free entry to the BKB exhibition for the day.

**DISCUSSION**

Ms Elizabeth Stack suggested an event in the CBD, such as the Village Green would be preferable so it is more visible to the community.

Ms Donna Moody suggested the entire week should be commemorated, not just have a one day event.

Ms Shirley Slater and Elizabeth Stack nominated to assist with Reconciliation Week planning.

Nyoongar Cultural Advisory Group Committee Minutes  
04 May 2022



**RECOMMENDATION**

That Council accepts the plans to host a National Reconciliation Week event on Friday 27 May at the Bilya Koot Boodja Centre, with free entry to the exhibition for the day.

**RECOMMENDATION / COUNCIL DECISION**

Minute No: NCAG. 34

Moved: Ms Donna Moody

Seconded: Ms Brenda DeAtta

That Council accepts the plan to host an event or events for the week of Reconciliation Week, 27 May 2022 – 3 June 2022.

**CARRIED 6/0**

Reason for change to Officer Recommendation

Following the recommendations from Ms Elizabeth Stack and Donna Moody the Committee formed the view that the entire week should be celebrated, rather than just one day.

Nyoongar Cultural Advisory Group Committee Minutes  
04 May 2022



Attachment 4: National Reconciliation Week 2022 Poster

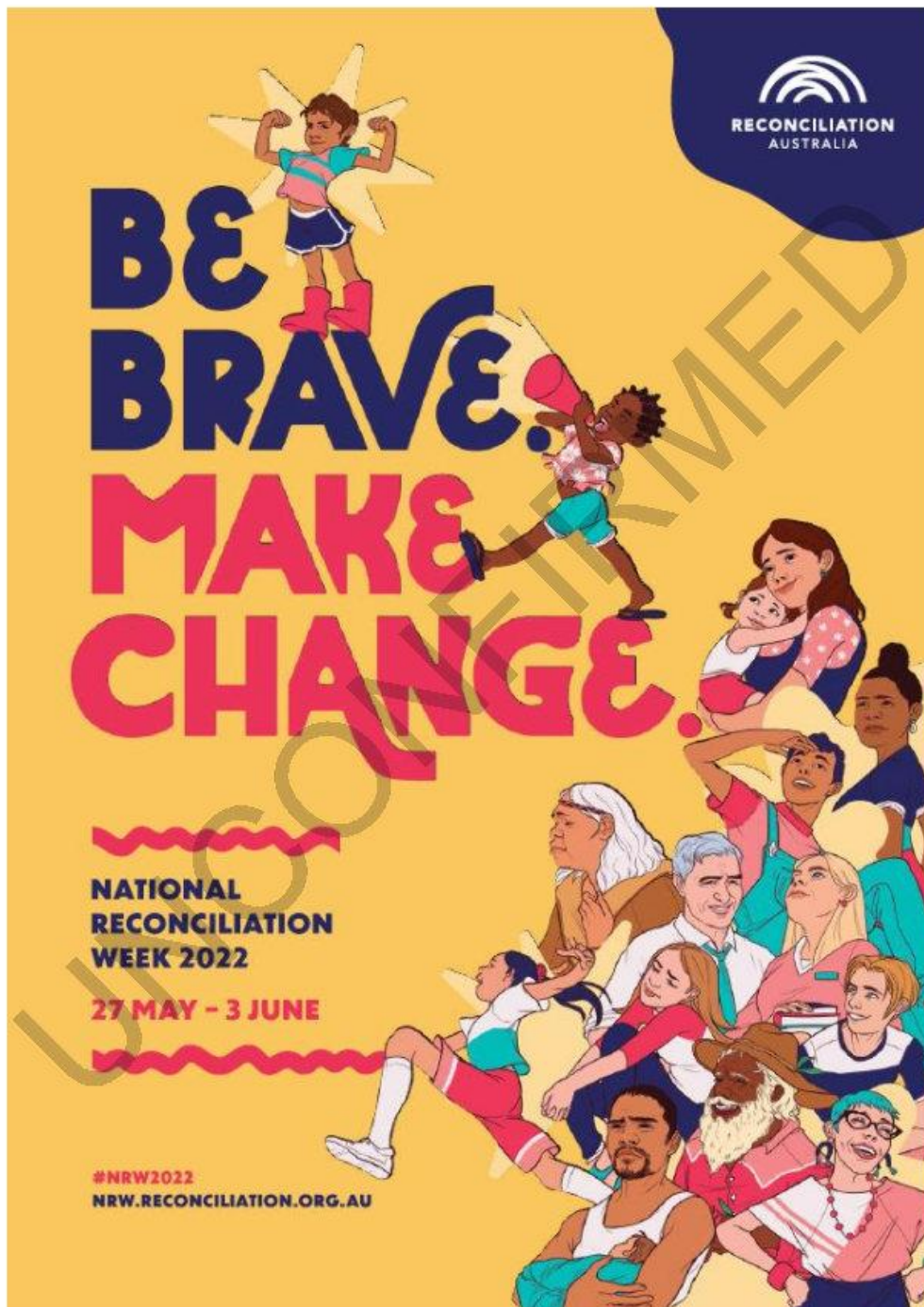

Nyoongar Cultural Advisory Group Committee Minutes  
04 May 2022



Agenda Item 7.3 was not considered at the meeting.

### 7.3 TRACKS & TRAILS MASTER PLAN CONSULTATION

|   |  |
|---|--|
| <b>File Reference:</b>                  | 2.1.3.7                                      |
| <b>Reporting Officer:</b>               | Jaime Hawkins, Community Development Officer |
| <b>Responsible Officer:</b>             | Jo Metcalf, Executive Manager                |
| <b>Officer Declaration of Interest:</b> | Nil  |
| <b>Voting Requirement:</b>              | Simple Majority                              |
| <b>Press release to be issued:</b>      | Nil  |

#### BRIEF

For the committee to provide input into the tracks and trails master plan.

#### ATTACHMENTS

Attachment 1: Base Map  
Attachment 2: Consultation Questions

#### A. BACKGROUND / DETAILS

At the meeting held 6 April 2022, Ms Megan Watson from Common Ground Trails made a presentation to the committee regarding the development of the Shire of Northam Tracks & Trails Master Plan. Ms Watson called for input from the advisory group regarding significant sites that have a story that can be shared, and sacred areas that are to be avoided all together. In particular, the Dornij Koorliny Trail was focused on.

Feedback forms were emailed to those with email access and were also made available from the BKB. No responses have been received.

#### B. CONSIDERATIONS

##### B.1 Strategic Community / Corporate Business Plan

Theme Area 4: Environment and Heritage  
Outcome 4.2: Northam honours, and is recognised for, its unique heritage and cultural identity  
Objective: There is a strong, respected and valued Aboriginal community and culture in the Shire of Northam

##### B.2 Financial / Resource Implications

Nil

##### B.3 Legislative Compliance



Nyoongar Cultural Advisory Group Committee Minutes  
04 May 2022



Nil.

**B.4 Policy Implications**

Nil.

**B.5 Stakeholder Engagement / Consultation**

The Nyoongar Cultural Advisory Group were consulted with at the meeting held 6 April 2022 and feedback forms made available.

**B.6 Risk Implications**

| Risk Category        | Description  | Rating<br>(likelihood x<br>consequence)        | Mitigation Action  |
|----------------------|--|--|--|
| Financial            | N/A  |  |  |
| Health & Safety      | N/A  |  |  |
| Reputation           | There are significant reputational risks should Council construct a track through a sacred area. | Major (4) x<br>Unlikely (2) =<br>Moderate (8)  | Ensure extensive consultation with Aboriginal Elders and Community.  |
| Service Interruption | N/A  |  |  |
| Compliance           | N/A  |  |  |
| Property             | N/A  |  |  |
| Environment          | Tracks and trails have a detrimental impact on natural environment.                              | Medium (3) x<br>Unlikely (2) =<br>Moderate (6) | Thorough research and consultation before the planning and construction of any tracks and trails through natural bushland. |

**C. OFFICER'S COMMENT**

The Committee are to be given the opportunity to provide any further feedback on the tracks and trails. It is requested that feedback forms be completed and returned as soon as possible.

Further consultation will occur prior to the endorsement of the final plan.

Nyoongar Cultural Advisory Group Committee Minutes  
04 May 2022

Attachment 1: Base Map

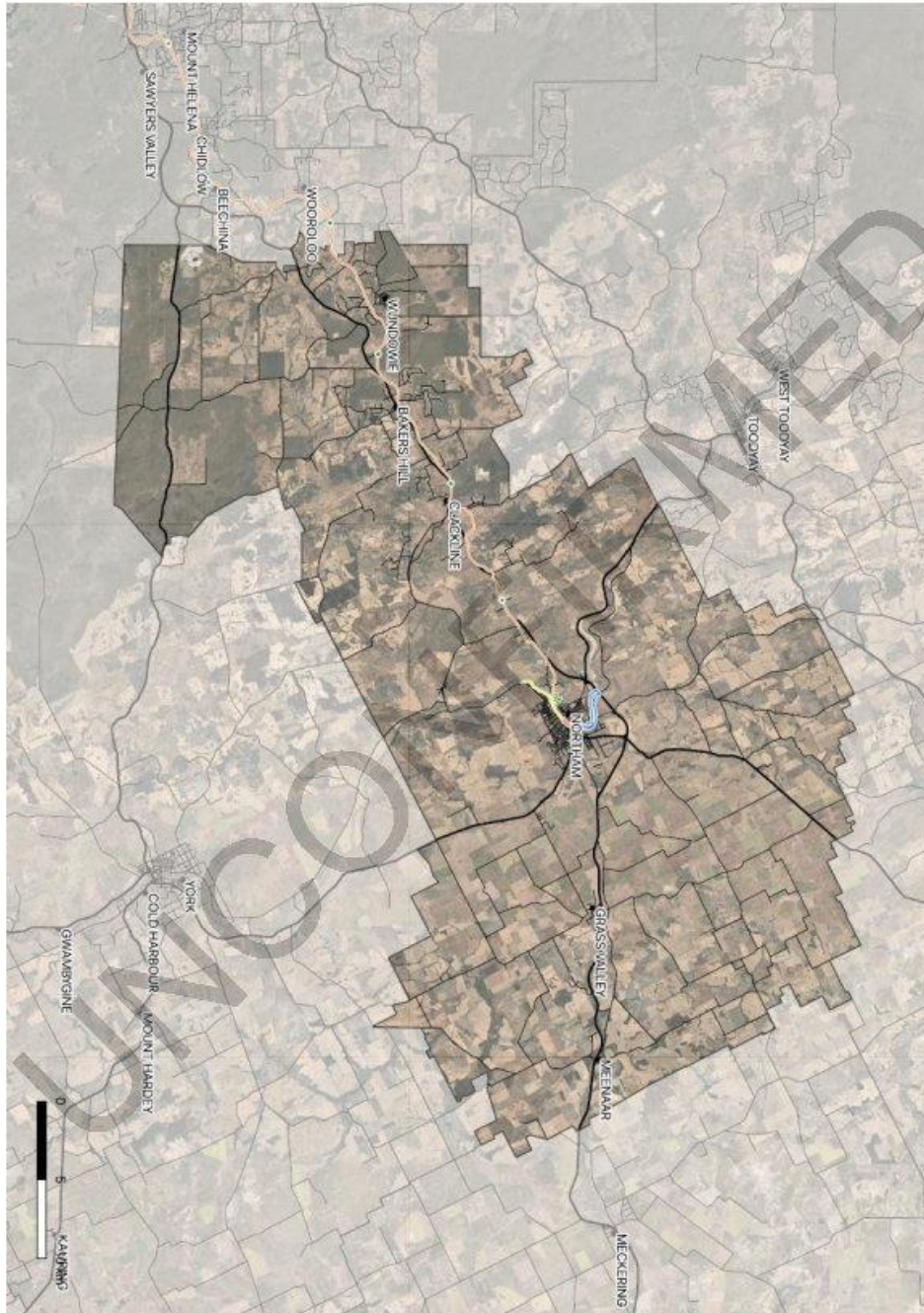

Nyoongar Cultural Advisory Group Committee Minutes  
04 May 2022



Attachment 2: Consultation Questions



Consultation & Engagement – Cultural Leaders

|                 |  |      |  |
|-----------------|--|------|--|
| NAME            |  | DATE |  |
| LEADERSHIP ROLE |  |      |  |

|          |  |
|----------|--|
| OVERVIEW | <p>The Trails Master Plan recommends that the Shire focus on celebrating cultural and environmental values as a key point of difference.</p> <p>The signature trail experiences are proposed to have a focus on opportunities to connect trail users to the cultural heritage values in the area.</p> <p><b>Example</b><br/>The Dorntj Koorliny Trail is proposed to connect trail users from the BKB Centre to Burlong Pool and the confluence of the Avon and Mortlock Rivers as key sites of cultural significance with opportunities for self-guided or guided cultural tours.</p> |
|----------|--|

| QUESTION  | COMMENT / FEEDBACK |
|---|--------------------|
| <p>Key sites of cultural significance identified in the Plan.<br/>Are Elders and Leaders comfortable with promoting access to:</p> <ul style="list-style-type: none"> <li>• Avon River,</li> <li>• Burlong Pool and</li> <li>• Enright Park</li> </ul>  |                    |
| <p>Are there stories or other sites that have potential to be incorporated into interpretation signs or tours?<br/>If so where?<br/>What is the story or site?<br/>How could we obtain further information?</p>   |                    |
| <p>Is there a desire to be involved in ongoing implementation of the Master Plan proposals?<br/><b>Example</b></p> <ul style="list-style-type: none"> <li>• Involvement in refining trail ideas,</li> <li>• Developing and running tours once trails are in place,</li> <li>• Development of ranger program to maintain trails</li> </ul> |                    |
| <p>Are there specific sensitive environment ecosystems or old growth trees that they Shire should identify and ensure are appropriately protected?</p>  |                    |

|            |              |
|------------|--------------|
| Created By | David Emery  |
| Date       | 6 April 2022 |
| Version    | 1            |

Nyoongar Cultural Advisory Group Committee Minutes  
**04 May 2022**



|   |  |
|---|--|
| Where are these located?<br>Is it of benefit to highlight these areas for trail users and provide information about protecting these ecosystems?<br>Is there cultural significance to these ecosystems? |  |
| In your opinion what benefits are there culturally on implementing a 'Trails Masterplan' within the Shire of Northam boundary?  |  |
| Were there any other cultural considerations that you would like to provide that may need to be considered with the implementation or planning for the 'Trails Masterplan'?                             |  |
| Other Comments:   |  |

**IMPORTANT** – This feedback is to be returned to [reccoord@northam.wa.gov.au](mailto:reccoord@northam.wa.gov.au) no later than 4pm Friday 22 April 2022.

Should you require further assistance please contact the Shire's Manager Recreation Services, David Emery on 962257 53 or the above email address.

| Your Details              |  |
|---------------------------|--|
| Preferred Contact Person: |  |
| Email address             |  |
| Contact No:               |  |

Name: \_\_\_\_\_

Signed: \_\_\_\_\_

|            |              |
|------------|--------------|
| Created By | David Emery  |
| Date       | 6 April 2022 |
| Version    | 1            |

Nyoongar Cultural Advisory Group Committee Minutes  
04 May 2022



Agenda Item 7.4 was not considered at the meeting.

#### 7.4 CULTURAL AWARENESS VIDEO

|   |  |
|---|--|
| <b>File Reference:</b>                  | 2.1.3.7                                  |
| <b>Reporting Officer:</b>               | Bev Jones, Human Resources Manager       |
| <b>Responsible Officer:</b>             | Jason Whiteaker, Chief Executive Officer |
| <b>Officer Declaration of Interest:</b> | Nil                                      |
| <b>Voting Requirement:</b>              | Simple Majority                          |
| <b>Press release to be issued:</b>      | Nil                                      |

#### BRIEF

To seek a recommendation from the Committee regarding the use of a cultural awareness training video produced for the Public Sector Commission for Shire of Northam staff.

#### ATTACHMENTS

Attachment 3: Video link (sent as a separate attachment)

#### A. BACKGROUND / DETAILS

The Shire of Northam is seeking to develop a cultural awareness package for new and existing staff. In the meantime, a video produced for the Public Sector Commission has been identified to fill the gap. This agenda item has been carried over from the previous meeting held 6 April 2022.

#### B. CONSIDERATIONS

##### B.1 Strategic Community / Corporate Business Plan

Theme Area 4: Environment and Heritage  
Outcome 4.2: Northam honours, and is recognised for, its unique heritage and cultural identity  
Objective: There is a strong, respected and valued Aboriginal community and culture in the Shire of Northam

##### B.2 Financial / Resource Implications

Nil.

##### B.3 Legislative Compliance

Nil.

Nyoongar Cultural Advisory Group Committee Minutes  
04 May 2022



**B.4 Policy Implications**

Nil.

**B.5 Stakeholder Engagement / Consultation**

Nil.

**B.6 Risk Implications**

| Risk Category        | Description  | Rating<br>(likelihood x<br>consequence) | Mitigation Action  |
|----------------------|--|---|--|
| Financial            | N/A  |   |  |
| Health & Safety      | N/A  |   |  |
| Reputation           | The video is presented for staff inductions, however is not culturally accurate for the Ballardong region. | Unlikely (2) x Minor (2) = Low (4)      | Video is endorsed by the NCAG prior to be integrated into the workplace induction package. |
| Service Interruption | N/A  |   |  |
| Compliance           | N/A  |   |  |
| Property             | N/A  |   |  |
| Environment          | N/A  |   |  |

**C. OFFICER'S COMMENT**

Cultural training in the workplace can enhance cultural sensitivity, competence and most importantly eliminate the risk of major miscommunication. The implementation of a tailored cultural awareness training package for Shire of Northam staff will enhance cultural understanding which will in turn encourage positive cross-cultural working relationships as well as positive relationships outside of work. Whilst the package is being created in preparation for endorsement by the Nyoongar Cultural Advisory Group, a video produced by the Public Sector Commission has been identified to hopefully educate staff and make them more culturally aware.

**RECOMMENDATION**

That Council accept the video produced by the Public Sector Commission to be used for staff cultural awareness training until the Shire's own training package is developed.

Nyoongar Cultural Advisory Group Committee Minutes  
04 May 2022



Agenda Item 7.6 was not considered at the meeting.

**7.6 REVIEW OF THE TERMS OF REFERENCE FOR THE NYOONGAR CULTURAL ADVISORY GROUP**

|   |  |
|---|--|
| <b>File Reference:</b>                  | 2.1.3.7  |
| <b>Reporting Officer:</b>               | Jaime Hawkins, Community Development Officer     |
| <b>Responsible Officer:</b>             | Jo Metcalf, Executive Manager Community Services |
| <b>Officer Declaration of Interest:</b> | Nil  |
| <b>Voting Requirement:</b>              | Simple Majority                                  |
| <b>Press release to be issued:</b>      | Nil  |

**BRIEF**

For the Committee to consider changes to the Terms of Reference for the Nyoongar Cultural Advisory Group.

**ATTACHMENTS**

Attachment 5: Terms of Reference Nyoongar Cultural Advisory Group with proposed changes

**A. BACKGROUND / DETAILS**

The current Terms of Reference states the following under Membership of the Committee:

The Advisory Group shall consist of elected members, designated Shire of Northam employees and Aboriginal and Torres Strait Islander community members as follows:

- Two (2) Elected Members and Two (2) Proxy Elected Members;
- One representative from each of the following families and one proxy representative;
  - Ryder
  - Garlett
  - Stack
  - Slater
  - McGuire
  - Kickett
  - Moody
  - Davis
- Two other Aboriginal and/or Torres Strait Islander Community Representatives

Nyoongar Cultural Advisory Group Committee Minutes  
**04 May 2022**



- Shire of Northam CEO or nominated Executive Manager.
- Member for Central Wheatbelt, State Legislative Assembly
- Member of the WA Police Force
- The CEO and or their nominee is to attend all meetings to provide advice and guidance to the committee. They do not have voting rights on the committee
- The local government shall provide secretarial and administrative support to the committee.

It is recommended that the Member for Central Wheatbelt, State Legislative Assembly; and member of the WA Police Force be removed as voting members of the committee and attendance be by invitation. It is also recommended that the Shire of Northam CEO or nominated Executive Manager be removed and the line remain that they shall attend all meetings to provide advice and guidance to the committee. They do not have voting rights on the committee.

**B. CONSIDERATIONS**

**B.1 Strategic Community / Corporate Business Plan**

Theme Area 4: Environment and Heritage  
 Outcome 4.2: Northam honours, and is recognised for, its unique heritage and cultural identity  
 Objective: There is a strong, respected and valued Aboriginal community and culture in the Shire of Northam

**B.2 Financial / Resource Implications**

Nil.

**B.3 Legislative Compliance**

Nil.

**B.4 Policy Implications**

Nil.

**B.5 Stakeholder Engagement / Consultation**

Nil.

**B.6 Risk Implications**

| Risk Category   | Description | Rating<br>(likelihood x consequence) | Mitigation Action |
|-----------------|-------------|--------------------------------------|-------------------|
| Financial       | N/A         |                                      |                   |
| Health & Safety | N/A         |                                      |                   |



Nyoongar Cultural Advisory Group Committee Minutes  
**04 May 2022**



|                      |   |                                  |  |
|----------------------|---|----------------------------------|--|
| Reputation           | Membership on the committee is not seen as representative of the Northam Ballardong Nyoongar Community. | Unlikely(2) x Minor(2) = Low (4) | Shire develops Terms of Reference and appoints representation in consultation with Ballardong Nyoongar Elders. |
| Service Interruption | N/A   |                                  |  |
| Compliance           | N/A   |                                  |  |
| Property             | N/A   |                                  |  |
| Environment          | N/A   |                                  |  |

**C. OFFICER'S COMMENT**

It is recommended that the Member for Central Wheatbelt, State Legislative Assembly; and member of the WA Police Force be removed as voting members and it be stated that their attendance shall be by invitation and they do not have voting rights (see attachment). These changes are proposed as not all meetings will have agenda items of relevance to these organisations and their non-attendance could result in the Committee not reaching a quorum. Voting on the committee should be reserved for the nominated Aboriginal representatives.

The Shire of Northam CEO or nominated Executive Manager is listed as a member of the Committee, however it is also stated further down that they shall attend all meetings to provide advice and guidance to the committee, but do not have voting rights on the committee. It is proposed they are removed from the membership list to avoid confusion.

**RECOMMENDATION**

**That Council accepts the changes to Membership of the Committee in the Nyoongar Cultural Advisory Group Terms of Reference as presented.**

Nyoongar Cultural Advisory Group Committee Minutes  
04 May 2022



Attachment 5: Terms of Reference with Proposed Changes

*Nyoongar Cultural Advisory Group Terms of Reference 2021 to 2023*

**TERMS OF REFERENCE  
SHIRE OF NORTHAM NYOONGAR CULTURAL ADVISORY GROUP**

**1. Objectives of the Shire of Northam NYOONGAR CULTURAL ADVISORY Group (NCAG)**

The primary objective of NCAG is to provide guidance and recommendations to the Shire of Northam on all Nyoongar related matters focusing on the BKB Centre for Nyoongar Culture & Environmental Knowledge and the development of a community wide Reconciliation Action Plan.

**2. Powers of the Northam NCAG**

NCAG is a formally appointed committee of Council and is responsible to that body. NCAG does not have executive powers or authority to implement actions in areas over which the CEO has legislative responsibility and does not have any delegated financial responsibility. NCAG does not have any management functions and cannot involve itself in management processes or procedures.

NCAG is to report to Council and provide appropriate advice and recommendations on matters relevant to its terms of reference in order to facilitate informed decision-making by Council in relation to the legislative functions and duties of the local government that have not been delegated to the CEO.

**3. Membership**

The Advisory Group shall consist of elected members, designated Shire of Northam employees and Aboriginal and Torres Strait Islander community members as follows:

- Two (2) Elected Members and Two (2) Proxy Elected Members;
- One representative from each of the following families and one proxy representative:
  - Ryder
  - Garlett
  - Stack
  - Slater
  - McGuire
  - Kickett
  - Moody
  - Davis
- Two other Aboriginal and/or Torres Strait Islander Community Representatives
- ~~Shire of Northam CEO or nominated Executive Manager~~
- Member for Central Wheatbelt, State Legislative Assembly by invitation. They do not have voting rights
- Member of the WA Police Force by invitation. They do not have voting rights
- The CEO and or their nominee is to attend all meetings to provide advice and guidance to the committee. They do not have voting rights on the committee
- The local government shall provide secretarial and administrative support to the committee.

COMMS-TR-02 Nyoongar Cultural Advisory Group Terms of Reference 2021 - 2023\_V3 - Copy  
COMMS-TR-02 Nyoongar Cultural Advisory Group Terms of Reference 2021 - 2023\_V3

Nyoongar Cultural Advisory Group Committee Minutes  
04 May 2022



*Nyoongar Cultural Advisory Group Terms of Reference 2021 to 2023*

#### 4. Meetings

The NCAG shall meet at least four times annually.

Additional meetings shall be convened at the discretion of the presiding member.

#### 5. Reporting

Minutes and recommendations of each NCAG meeting shall be presented to the next Ordinary Meeting of the Council.

The NCAG is responsible for liaising with all relevant business units to complete and submit the RAP Impact Measurement Questionnaire to Reconciliation Australia annually.

#### 6. Duties and Responsibilities

The following activities will be carried out by the NCAG:

- Provide guidance and assistance to Council on the future development of the BKB.
- Provide input and advice in relation to the development of a Shire of Northam Reconciliation Action Plan.
- Meet with the Full Shire of Northam Council, not less than once each year to discuss progress of the Reconciliation Action Plan and BKB
- Develop a RAP within the context of the Shire of Northam's core business and in-line with:
  - Over-arching community strategic plan and corporate business plan.
  - Any existing Aboriginal and Torres Strait Islander employment strategy
  - Any existing supplier diversity strategy
  - Any existing equity and diversity policies.
- Establish a collaborative/consultative process for engaging staff across the organisation so that they can provide ideas for the RAP and comment on drafts.
- Develop a project plan and timeline to development, launch and begin implementing the RAP, including consultation with Reconciliation Australia at regular intervals.
- Regularly liaise with relevant business units and key stakeholders to review progress of RAP actions and:
  - Report RAP progress to internal and external stakeholders, including Reconciliation Australia, Shire of Northam elected members and staff, and Aboriginal and Torres Strait Islander stakeholders
  - Reflect on key learnings in the development of new RAPs.
  - Consider RAP implementation issues and consult with relevant business units to find solutions.
- Develop a new RAP when the current plan expires.

[COMMS-TR-02 Nyoongar Cultural Advisory Group Terms of Reference 2021 - 2023\\_V3 - Copy](#)  
[COMMS-TR-02 Nyoongar Cultural Advisory Group Terms of Reference 2021 - 2023\\_V3](#)

Nyoongar Cultural Advisory Group Committee Minutes  
04 May 2022



**8. URGENT BUSINESS APPROVED BY DECISION**

Cr Michael Ryan invited the Committee to raise items they would like to see included in the agenda for the next meeting.

Ms Elizabeth Stack requested that tracks and trails be discussed again.

Ms Donna Moody requested that the CEO provide other options for the structure of the committee that would allow for sitting fee payment.

Mrs Yvonne Kickett requested that NAIDOC Week event planning be included.

Cr Attila Menoshelyi requested the meeting dates be changed from first Wednesday of the month, as this clashes with another meeting he and other committee members are involved in.

**9. DATE OF NEXT MEETING**

To be advised.

**10. DECLARATION OF CLOSURE**

There being no further business, the Presiding Member Cr Michael Ryan declared the meeting closed at 5:20pm.

"I certify that the Minutes of the Nyoongar Cultural Advisory Group Committee held on Wednesday, 4 May have been confirmed as a true and correct record."

\_\_\_\_\_ Presiding Member

\_\_\_\_\_ Date

## 13. OFFICER REPORTS

### 13.1 CEO'S Office

#### 13.1.1 Lease Agreement for Northam Pistol Club, Portion of Reserve 3303, 98 Clarke Street Northam

|   |  |
|---|--|
| <b>File Reference:</b>                  | A15653                                       |
| <b>Reporting Officer:</b>               | Alysha McCall, Acting Governance Coordinator |
| <b>Responsible Officer:</b>             | Jason Whiteaker, Chief Executive Officer     |
| <b>Officer Declaration of Interest:</b> | Nil  |
| <b>Voting Requirement:</b>              | Simple Majority                              |
| <b>Press release to be issued:</b>      | No   |

### BRIEF

For Council to approve a lease for a portion of Reserve 3303, 98 Clarke Street Northam to the Northam Pistol Club Inc.

### ATTACHMENTS

Attachment 1: Map of Area.

---

## A. BACKGROUND / DETAILS

The existing lease agreement expired on 30 June 2022 and is due for renewal.

The Northam Pistol Club is an active group which holds regular meets and tournaments.

## B. CONSIDERATIONS

### B.1 Strategic Community / Corporate Business Plan

Outcome 3: A happy, healthy, and connected community.

Objective 3.2: Grow participation in sport, recreation and leisure activities with quality regional facilities.

### B.2 Financial / Resource Implications

Nil.

### B.3 Legislative Compliance

Local Government Act 1995

Section 3.58 of the *Local Government Act 1995* details the requirements for the disposing of property.

*Local Government (Functions and General)*

Regulation 30 of the *Local Government (Functions and General) Regulations 1996* details dispositions of property which are excluded from the Act. As this disposal relates to recreational and sporting purposes it is exempt from section 3.58 of the Act.

*Land Administration Act 1997*

As the proposed lease is on a Reserve, in accordance with section 18 of the Land Administration Act 1997 approval from the Minister for Lands is required.

## **B.4 Policy Implications**

### A 8.5 Management of Council Property Leases

#### 2.0 Community Based Not-for-profit Lease: Reg 30(2)(b)

The basic principles considered in establishing a standard lease fee reflects a fair and equitable contribution of provision of a facility, the venue's pattern of use, location and the potential to obtain Community Grants assistance, as follows:-

- 2.1 The Shire levy an annual administration rent equivalent to the cost of building insurance, to all community, sport and recreation groups, not including the abovementioned Community Halls, and is reviewed annually.
- 2.2 Lessees or Licensees will be responsible for the full cost of the lease document preparation, registration and other costs associated with the execution of the agreement.
- 2.3 Lessees or Licensees must agree with Council to manage the "Demised Premises" on behalf of the community and to offer a service to the community that provides a net benefit.
- 2.4 The Lessee or Licensee will be responsible for the payment of outgoing, operating costs, and minor maintenance obligations.
- 2.5 The Lessee or Licensee will not be responsible for Shire land rates, but will be responsible for rubbish service rates.
- 2.6 The Shire will insure the "Demised Premises" at replacement value and pass on the cost to the Lessee as per 2.1. The Shire will perform any structural repairs, improvements and maintenance in accordance with levels determined within its budget forecast.
- 2.7 In the case of the Lessee or Licensee who leases a Council building and obtains approval to carry out extensions, alterations and/or additions, Council will insure the improvements as part of its insurance portfolio at replacement value.
- 2.8 The Lessee or Licensee will be responsible for contents insurance for their contents, and also hold public liability for their activities and

- workers compensation insurance for their employees (if applicable) to the value stipulated in the agreement.
- 2.9 The Lessee or Licensee will be responsible for the cost of repair of any internal damage, vandalism, corrective maintenance or damage to external doors, glass windows, security lighting and any other external facility through misuse by a club representative, member or guest. The Shire may carry out any corrective works and recoup the full cost from the Lessee.
  - 2.10 The Lessee or Licensee will be responsible for keeping the building clean and tidy at levels predetermined within the agreement.
  - 2.11 The Lessee or Licensee will not incur any costs for property damage excluding contents occasioned by fire, fusion, explosion, lightning, civil commotion, storm, tempest, or earthquake.
  - 2.12 On an annual basis, Lessees and Shire representatives will meet to carry out a property inspection to determine the extent to which the Lessee or Licensee have met their lease/licence obligation and to consider any specified building maintenance schedules for the following twelve month period within the Shire's budget parameters.

Delegated Authority Register

Delegation F06 allows for the disposal of property by lease or licence. As the leased area is greater than 1,000m<sup>2</sup> this lease cannot be approved under delegated authority.

**B.5 Stakeholder Engagement / Consultation**

The Northam Pistol Club have confirmed that they wish to renew the lease.

**B.6 Risk Implications**

| Risk Category        | Description | Rating<br>(likelihood x consequence) | Mitigation Action |
|----------------------|-------------|--------------------------------------|-------------------|
| Financial            | Nil.        |                                      |                   |
| Health & Safety      | Nil.        |                                      |                   |
| Reputation           | Nil.        |                                      |                   |
| Service Interruption | Nil.        |                                      |                   |
| Compliance           | Nil.        |                                      |                   |
| Property             | Nil.        |                                      |                   |
| Environment          | Nil.        |                                      |                   |

**B.7 Natural Environment Considerations**

Nil.

### C. OFFICER'S COMMENT

Officers have recently been made aware of unauthorised building works on the Reserve and are currently working with the Northam Pistol Club to obtain relevant approvals.

#### RECOMMENDATION

**That Council:**

1. Lease a portion of Reserve 3303, 98 Clarke Street, Northam to the Northam Pistol Club Inc. for a period of five (5) years in accordance with section 2.0 of Council Policy A 8.5 Management of Council Property Leases and subject to:
  - a. Section 18 approval under the *Land Administration Act 1997* being provided by the Minister for Planning, Lands and Heritage.



Attachment 1



## 13.2 ENGINEERING SERVICES

### 13.2.2 RFQ 10 of 2022 Spencers Brook Road Spray Seal & Asphalt Works

|   |   |
|---|---|
| <b>File Reference:</b>                  | 8.2.9.1   |
| <b>Reporting Officer:</b>               | Scott Patterson, Executive Manager Engineering Services |
| <b>Responsible Officer:</b>             | Scott Patterson, Executive Manager Engineering Services |
| <b>Officer Declaration of Interest:</b> | Nil   |
| <b>Voting Requirement:</b>              | Simple Majority   |
| <b>Press release to be issued:</b>      | No  |

#### BRIEF

For Council to consider submissions received in response to the Request for Quote (RFQ) 10 of 2022 – Spencers Brook Road Spray Seal & Asphalt Works. This report provides details of the submissions received and identifies a recommended contractor to complete the works.

#### ATTACHMENTS

Attachment 1: Evaluation report (Provided as a separate confidential attachment).

---

#### A. BACKGROUND / DETAILS

Spencers Brook Road project is a fully funded project under the Regional Road Safety Program endorsed by Council as a part of the 2021/2022 financial year's budget.

In compliance with legislative requirements, a request for these works was prepared and advertised on Tuesday 05 July 2022 to Friday 15 July 2022 in order to seek suitably qualified contractors to complete the works on the Shire's behalf.

#### B. CONSIDERATIONS

##### B.1 Strategic Community / Corporate Business Plan

Theme Area: Place

Outcome 9: Safe roads and greater use of sustainable transport options

Objective 9.1: Maintain a safe, efficient road network and supporting infrastructure.

## **B.2 Financial / Resource Implications**

The 2021/22 adopted budget made the following budget provisions for these projects:

Job 3680 Spencers Brook Road SLK 0.00-23.63 \$1,413,692 ex GST

The Spencers Brook Road project consists of three main components of work, being:

1. Road shoulder reconstruction
2. Spray seal/asphalt works
3. Line marking

Road shoulder reconstruction has already been awarded by council at a cost of \$851,583.88 ex. GST (RFQ 03/2022).

With a value of work of \$318,926.62 ex GST being recommended for award under this contract, this will leave \$243,181.50 for the line marking component of works. The line marking component being estimated at around \$250,000-\$300,000 to complete.

## **B.3 Legislative Compliance**

Section 3.57 of the Local Government Act 1995 requires a local government to invite tenders before it enters into a contract of a prescribed kind under which another person is to supply goods and services.

The Local Government (Functions & General) Regulations 1996 prescribe the manner in which Tenders are to be called and assessed.

The Local Government (Functions & General) Regulations 1996 additionally prescribes that tenders do not have to be publicly invited according to the requirements if the supply of the goods or services is to be obtained through the WALGA Preferred Supplier Program.

## **B.4 Policy Implications**

Policy F 4.2 – Purchasing and Tendering Policy.

## **B.5 Stakeholder Engagement / Consultation**

These are planned capital works projects. The stakeholders will be notified of the proposed work under contract via works notification.

### B.6 Risk Implications

| Risk Category        | Description                            | Rating<br>(likelihood x consequence)           | Mitigation Action  |
|----------------------|--|--|--|
| Financial            | Cost of works exceed budget allowance. | Unlikely (2) x<br>Medium (3) =<br>Moderate (6) | Contract will be monitored closely. Cost variation to be rejected or adjusted as necessary.        |
| Health & Safety      | Medical type injury                    | Unlikely (2) x<br>Medium (3) =<br>Moderate (6) | Compliance to OHS & E policy and standard procedures as part of contract.                          |
| Reputation           | Customer complaints                    | Unlikely (2) x<br>Medium (3) =<br>Moderate (6) | Complaints management protocol for swift resolution under contract, and ongoing works supervision. |
| Service Interruption | Delay in project delivery              | Unlikely (2) x<br>Medium (3) =<br>Moderate (6) | Works programme will be monitored and followed as a part of contract                               |
| Compliance           | Substandard work                       | Unlikely (2) x<br>Minor (2) = Low (4)          | Quality assurance standards to be complied as part of contract                                     |
| Property             | Nil                                    | -  | -  |
| Environment          | Nil                                    | -  | -  |

### C. OFFICER'S COMMENT

In response to the advertised request, three (3) submissions were received, of which all were compliant:

1. Fulton Hogan Industries Pty Ltd
2. KEE Surfacing Pty Ltd
3. Supercivil Pty Ltd

A full report on the procurement process and outcomes have been provided as a separate confidential attachment.

#### RECOMMENDATION

##### **That Council:**

1. **Award Request for Quote 10 of 2022 – Spencers Brook Road Spray Seal and Asphalt Works for \$318,926.62(ex GST) to Fulton Hogan Industries Pty Ltd.**
2. **Authorise the Chief Executive Officer to make minor variations (maximum increase of 5%) to the awarded price prior to entering a contract with Fulton Hogan Industries Pty Ltd.**

### 13.3 DEVELOPMENT SERVICES

Cr C R Antonio declared a "Financial" interest in item 13.3.1 – Proposed Amendment – Co-operative Bulk Handling, Leeming Road, Grass Valley as Cr Antonio's farming operation holds a \$2 share in CBH.

#### 13.3.1 Proposed Amendment – Co-Operative Bulk Handling, Leeming Road, Grass Valley

|   |  |
|---|--|
| <b>Address:</b>                         | Lots 9002, 18, 19 and 20 Leeming Road, Grass Valley (Avon Industrial Park) |
| <b>Owner:</b>                           | Western Australian Land Authority  |
| <b>Applicant:</b>                       | Co-operative Bulk Handling Ltd   |
| <b>File Reference:</b>                  | P21083.2 / A16428  |
| <b>Reporting Officer:</b>               | Jacky Jurmann, Manager Planning & Environment                              |
| <b>Responsible Officer:</b>             | Chadd Hunt, Executive Manager Development Services                         |
| <b>Officer Declaration of Interest:</b> | Nil  |
| <b>Voting Requirement:</b>              | Simple   |
| <b>Press release to be issued:</b>      | No   |

#### BRIEF

An application has been received to amend the development approval (ref: P21083) to construct an additional 3 open bulkheads at CBH's temporary grain receival and handling facility in the Avon Industrial Park.

#### ATTACHMENTS

Attachment 1: Application documents.

#### A. BACKGROUND / DETAILS

##### Background

Council at its Ordinary Meeting held on 21 July 2021 resolved to grant development approval for the construction of a temporary grain receival and storage facility at Lots 9002, 18, 19 and 20 Leeming Road, Grass Valley.

The existing development currently consists of six open bulkheads, temporary sample hut, weighbridge and staff amenities.

The original development approval was granted for a temporary period of 12 months. A 24 month extension was granted by Council at last month's OCM to enable CBH to continue to provide additional grain storage and to plan for the development of their new permanent facility on the site.

### Application Details

CBH is now seeking approval to construct an additional three open storage bulkheads with a capacity of 123,140 tonnes to provide emergency storage to cater for the current forecast of another significant harvest and the large amount of carryover grain from the previous season.

The existing temporary weighbridge, sample hut and staff facilities will continue to be utilised. New access roads and stormwater detention are also proposed as part of this application.

## **B. CONSIDERATIONS**

### **B.1 Strategic Community / Corporate Business Plan**

Theme Area: Governance & Leadership

Outcome: Residents and other stakeholders are actively listened to and their input into decision-making processes is valued.

Objective: Decisions made by the Shire of Northam are communicated and the reasoning clearly articulated to residents and stakeholders.

### **B.2 Financial / Resource Implications**

There are no financial / resource implications associated with this proposal. The relevant application fee has been paid.

### **B.3 Legislative Compliance**

Clause 77(1) of the *Planning and Development (Local Planning Schemes) Regulations 2015* enables an owner to request the local government to do any or all of the following:

- (a) to amend the approval so as to extend the period within which any development approved must be substantially commenced;
- (b) to amend or delete any condition to which the approval is subject;
- (c) to amend an aspect of the development approved, which if amended, would not substantially change the development approved;
- (d) to cancel the approval.

The application to construct an additional three bulkheads can be considered under the provisions of sub-clause (c) as it is amending an aspect of the development approval that does not substantially change the development approval (i.e. a temporary grain receipt and handling facility).

### **B.4 Policy Implications**

There are no policy implications associated with this proposal.

### **B.5 Stakeholder Engagement / Consultation**

Stakeholder Engagement

The Applicant has consulted with Main Roads WA who have advised that they have no objections to the approval of the three additional bulkheads.

### Consultation

The development proposal did not require any public consultation as it is a 'D' (discretionary) use under the provisions of the Northam Local Planning Scheme No. 6.

### **B.6 Risk Implications**

| <b>Risk Category</b> | <b>Description</b>                  | <b>Rating<br/>(likelihood x<br/>consequence)</b> | <b>Mitigation Action</b>           |
|----------------------|-------------------------------------|--|------------------------------------|
| Financial            | Nil                                 | Nil  | Nil                                |
| Health & Safety      | Nil                                 | Nil  | Nil                                |
| Reputation           | Nil                                 | Nil  | Nil                                |
| Service Interruption | Nil                                 | Nil  | Nil                                |
| Compliance           | Conditions not being complied with. | Minor (2) x Unlikely (2) = Low (4)               | Monitor conditions for compliance. |
| Property             | Nil                                 | Nil  | Nil                                |
| Environment          | Nil                                 | Nil  | Nil                                |

### **B.7 Natural Environment Considerations**

Not applicable.

### **C. OFFICER'S COMMENT**

The assessment of the original application identified the main issues to be traffic generation and stormwater management.

#### Traffic

A Traffic Impact Assessment has been submitted with the application to provide an assessment of the increase in traffic movements as a result of the additional storage, which will increase from 251kt to 374kt.

The TIA indicates that the truck movements for the upcoming season will exceed the existing capacity and last year's truck movements during harvest. The intent of the additional emergency storage is to reduce the outgoing movements during harvest as shown in the scenarios in the following table from page 3 of the TIA:



| Item                                | 2021/22 Harvest | 2022/23 without emergency | 2022/23 with emergency |
|-------------------------------------|-----------------|---------------------------|------------------------|
| Tonnes Received (t)                 | 109,597         | 231,021                   | 231,021                |
| Truck Payload (tonnes)              | 50.1            | 50.1                      | 50.1                   |
| Total Harvest Receival Movements    | 2,188           | 4,611                     | 4,611                  |
| Total Harvest Out Loading Movements |                 | 2,310                     | -                      |
| Total Harvest Movement              | 2,188           | 6,922                     | 4,611                  |

CBH have consulted Main Roads WA regarding the proposed development and resulting additional traffic generation. Main Roads have raised no objections to approval of the development relating to potential impacts from the additional truck movements on Great Eastern Highway and the intersection with Leeming Road.

Shire Officers agree with the Main Roads assessment regarding the operational phase of the development. Leeming Road is capable of catering for additional heavy vehicle movements and is constructed to acceptable standard for accessing and egressing the site from an easterly direction, which is the direction the TIA indicates the harvest traffic will be generated.

However, the TIA does not provide an assessment of the traffic movements associated with the construction phase of the development. CBH Officers have advised that approximately 20,000 tonnes of gravel will be required to construct the additional bulkheads, which equates to approximately 350 truck movements importing gravel onto the site from a local supplier.

Previously the gravel was sourced from a local gravel pit on Gentle Road entering the site from an easterly direction, which resulted in a number of complaints being received regarding the impacts on the condition of Grass Valley South Road. To better understand and manage the number, frequency and impact of the truck movements during the construction phase, a condition is recommended requiring submission and approval of a Construction Management Plan.

#### Stormwater

The development application also contains a Stormwater Management Plan, which proposes the construction of an additional onsite drainage basin to manage stormwater runoff from the proposed bulkheads and associated accessways to retain manage stormwater on-site.



### Future Development

CBH have indicated that a masterplan for the site is currently being prepared and that they are keen to discuss their plans with Shire Officers in the near future.

Scheme Amendment No. 16 that proposes to rezone portions of the land to General Industry to facilitate the future development of the site by CBH, including construction of a rail spur, is currently with the Western Australian Planning Commission for final approval.

### Conclusion

The approval of this application will not substantially change the intent of the original development approval to develop the land for the purposes of a temporary grain receival and storage facility, and is acceptable to consider under the provisions of clause 77 of the Deemed Provisions.

The application is recommended for approval subject to the reimposition of the original conditions of approval, except where varied by this amendment including the requirement for approval of a Construction Management Plan.

## **RECOMMENDATION**

### **That Council resolves to:**

1. **Accept** that the development application reference P21083.2 as detailed on the development application form dated 27 August 2020 is appropriate for consideration in accordance with regulation 77 of the *Planning and Development (Local Planning Schemes) Regulations 2015*;
2. **Approve** the development application reference P19080.1 as detailed on the development application form dated 28 July 2022 and accompanying plans:
  - Site Plan – 801-ENG-CI-DCO-0015; Rev. A;
  - Standard Elevation Drawing – S119-ENG-ST-DGA-0003; Rev. 0;
  - Standard DOG Drawing – S040-ENG-ME-DGA-0010; Rev. 0;
  - Stormwater Management Plan – Shawmac dated 27/07/2022;
  - Traffic Impact Assessment – Shawmac dated 27/07/2022.

in accordance with clause 68 of Schedule 2 (Deemed Provisions) of the *Planning and Development (Local Planning Schemes) Regulations 2015* and the provisions of the Shire of Northam Local Planning Scheme No. 6, for the proposed amendments to the approved temporary grain receival and storage facility at Lot 9002 Leeming Road, Grass Valley.

3. **Add** an additional condition (No. 9) of development approval (ref: P21083) dated 21 July 2021 and as amended on 20 July 2022 (P21083.1) to read:

“A Construction Management Plan shall be submitted for approval to the Shire of Northam prior to commencement of works. The Construction Management Plan shall address dust, noise, waste management, storage of materials, traffic management and site safety/security. The Construction

**Management Plan is to be complied with for the duration of the construction of the development.”**

- 4. Advise the Applicant that all other conditions of the development approval (P21083) dated 21 July 2021 and as amended on 20 July 2022 (P21083.1) remain unchanged.**

## Attachment 1: Application documents



28 July 2022

Chadd Hunt, Executive Manager Development Services  
Shire of Northam  
Via email: [emds@northam.wa.gov.au](mailto:emds@northam.wa.gov.au)

Dear Chadd,

### **LOT 9002 LEEMING ROAD, GRASS VALLEY, WA 6403 STORAGE ADDITIONS TO EXISTING GRAIN HANDLING & STORAGE FACILITY**

CBH is seeking development approval from the Shire of Northam for proposed additions (storage bulkheads) to an existing grain handling and storage facility located at Lot 9002 Leeming Road, Grass Valley. The subject application is prepared in accordance with Schedule 2 (Deemed Provisions) of the Planning and Development (Local Planning Schemes) Regulations 2015 and the Shire of Northam Local Planning Scheme No. 6.

#### **Site Details**

Lot 9002 Leeming Road, Grass Valley (subject site) is located within the Avon Industrial Park as shown in Figure 1 below.



Figure 1: Location Plan

### Background

At the 21 July 2021 Ordinary Council Meeting, Council resolved to approve an application to obtain development approval to construct a temporary grain receival and storage facility at its Meenaar site located within the Avon Industrial Park. Condition 2 of this development approval limited the approval to a period of 12 months from the date of the commencement of the approved use.

CBH lodged a further development application to amend this condition 2 which time limited the use of the facility to 12 months. At the 20 July 2022 Ordinary Council Meeting, Council resolved to approve the amended development application for the continued use of the temporary grain receival and storage facility for a further 24 months.

As you know, CBH had a record harvest last year where its existing storage infrastructure was not enough to keep up with the record crop. The Shire of Northam assisted CBH with this storage shortfall through approving this development application for open storage bulkheads at the Meenaar CBH site.

Given the current forecast of another significant harvest for FY22/23 and the large amount of carryover grain that remains at many of our receival sites, we have identified the potential need to build emergency storage at identified sites with forecasted storage deficits for this harvest. The Meenaar CBH site is one of these sites where there is a strong likelihood that emergency storage could be needed. As such CBH is seeking development approval from the Shire of Northam for an additional three storage bulkheads.

### Context and Land Use

The subject land is located within the Shire of Northam. Access to the site is from the south via Leeming Road which is an access road under the control of the Shire of Northam. The subject site is zoned 'general industry' under the Shire's Local Planning Scheme No. 6. The subject site is surrounded by 'rural' zoned land to the south and west and land immediately east of the subject site is also zoned 'general industry'. The site is adjacent to a parks and recreation reserve to the north than buffers land reserved as railway.

### Town Planning Considerations

The proposed development is considered to be consistent with Clause 68 of Schedule 2 (Deemed Provisions) of the Planning and Development (Local Planning Schemes) Regulations 2015 and the provisions of the Shire of Northam Local Planning Scheme No. 6. The subject land is zoned 'general industry' under the Shire's Local Planning Scheme No. 6. The development proposed does not require any public consultation as it is a 'D' (discretionary) use under the provisions of Local Planning Scheme No. 6.

Through their assessment of the previous application, the Shire of Northam identified the main issues to be traffic generation and stormwater management. Both issues were satisfactorily addressed by CBH and conditions of development approval were able to ensure that there were no adverse effects on the locality. CBH would be supportive of similar conditions being imposed on any subsequent development approval to ensure any potential impacts continue to be mitigated appropriately as it is noted that there have been specific concerns in relation to the impact of the facility on both Leeming and Grass Valley South roads. Notwithstanding a Stormwater Management Plan and Traffic Impact Statement have been provided with lodgement of the application to assist with the Shire's consideration of the proposal.

### Traffic Management

As CBH are expecting another significant harvest in 2022/23 in order for our network to be able to service growers and cope with the task we have identified sites throughout the network where emergency storage is required. We propose to construct 3 new temporary OBH's with nameplate storage capacity of 123kt at Meenaar. This will increase the total site storage capacity from 251kt to 374kt. Note that the total site storage capacity includes 109kt which is expected to be held at the site as carryover grain from the prior year. The following notes are applicable to the Shire's consideration of storage capacity and its traffic impacts:

- Listed capacity is also not an accurate representation of what can be received due to operational intricacies that impact the sites. This namely because of "loss by division/loss by commodity" where multiple grain types are required to be stored/tarped within the same OBH, resulting in less efficient storage.
- The max case does not take into account the carryover amounts which refer to the amounts that will be retained/store in the storage from the prior year.
- Thereby reducing the effective storage amount for the current period by the carryover amount, our carryover estimate leading in to the 2022/23 harvest is 109kt.
- This means that the effective max storage capacity for the 2022/23 harvest with the proposed emergency storage build is 265kt.
- The effect of constructing the emergency storage is that out loading movements during the busy harvest period to keep the site open for grower receivals are eliminated.

Based on the average payload of 50.1t, the table below provides an estimate of the FY22/23 harvest period truck movements, with and without the proposed emergency OBH and with comparison to the previous year's volumes and movements.

| Item                                | 2021/22 Harvest | 2022/23 without emergency | 2022/23 with emergency |
|-------------------------------------|-----------------|---------------------------|------------------------|
| Tonnes Received (t)                 | 109,597         | 231,021                   | 231,021                |
| Truck Payload (tonnes)              | 50.1            | 50.1                      | 50.1                   |
| Total Harvest Receival Movements    | 2,188           | 4,611                     | 4,611                  |
| Total Harvest Out Loading Movements |                 | 2,310                     | -                      |
| Total Harvest Movement              | 2,188           | 6,922                     | 4,611                  |

As shown, the movements for FY22/23 regardless of the emergency TBH construction are expected to exceed the existing capacity and last year's truck movements, but the construction of the emergency TBH allows movements to be reduced in comparison to the scenario where the emergency TBH is not installed for the 2022/2023 harvest. Further detail on the impact of roads is provided under Section 4.2 of the Traffic Impact Statement that is provided in conjunction with lodgement of this application.

Stormwater Management

An onsite drainage basin will be constructed that caters for a 5-year ARI event with all stormwater runoff from the proposed bulkheads and associated accessways directed to this drainage basin system where all surface water will be detained on-site up to the 5-year ARI event. A Stormwater Management Plan has been provided in conjunction with lodgement of the application for the Shire's consideration.

Noise & Dust Management

CBH shall ensure that noise from the specification and installation of any mechanical equipment as well as traffic and construction noise does not exceed levels prescribed in the *Environmental Protection (Noise) Regulations 1997*, when it is received at a neighbouring property. CBH undertakes frequent noise and dust monitoring across its sites to ensure that dust and noise levels are measured and are mitigated whenever there is an exceedance.

**Conclusion**

The proposed addition is aligned with the planning framework for the area specifically the general industry zone and it is not considered to result in any new amenity impacts to the surrounding area. CBH respectfully requests the Application for Development Approval is considered by the Shire of Northam expeditiously given the straightforward nature of the application, that it is already constructed and its general compliance with the Shire's planning framework. Should you have any question in relation to the details provided in this submission, please contact Timothy Roberts on 9216 6061 or [timothy.roberts@cbh.com.au](mailto:timothy.roberts@cbh.com.au)

Yours Sincerely,



**Timothy Roberts**  
Specialist – Regulatory Approvals Adviser

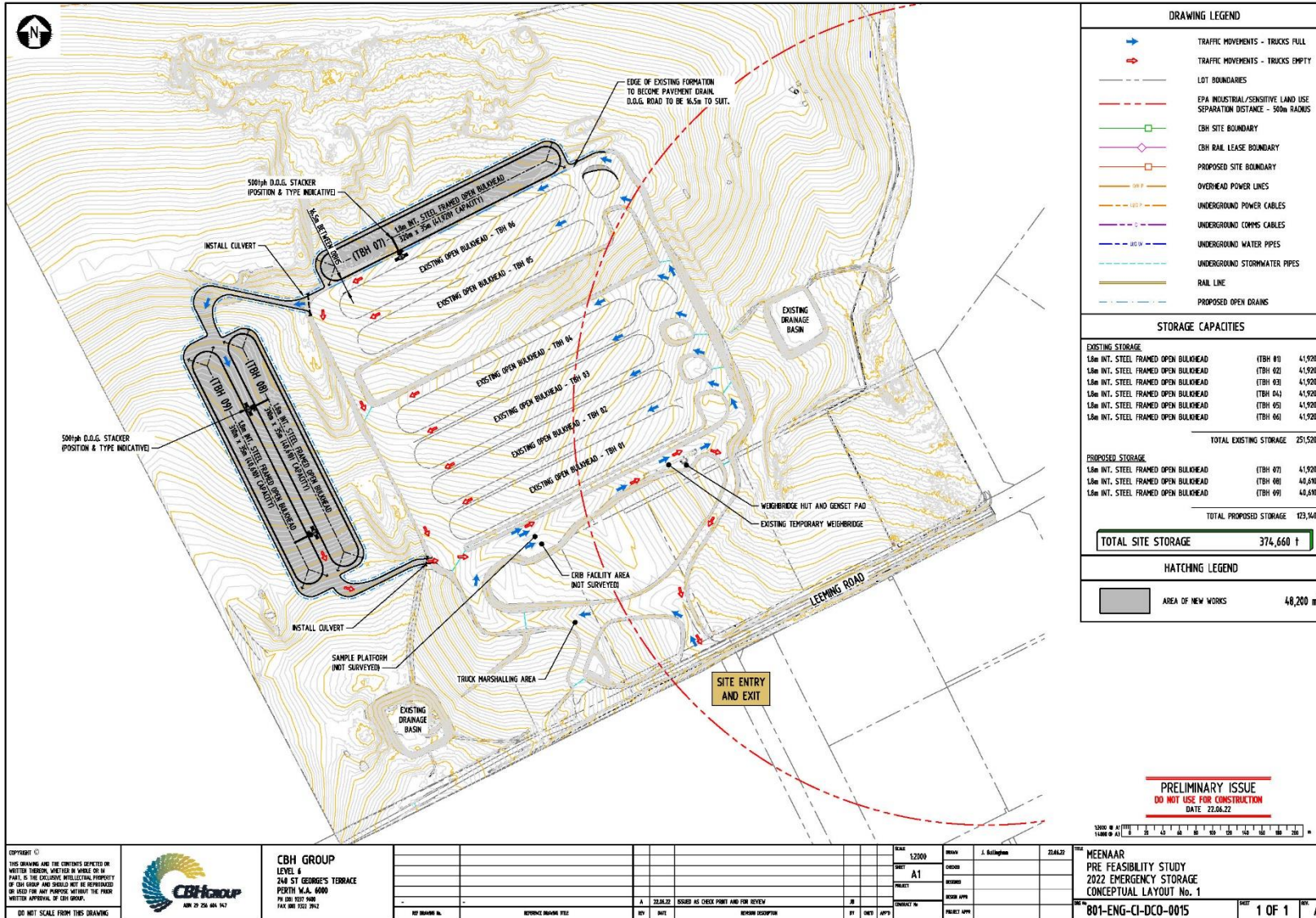



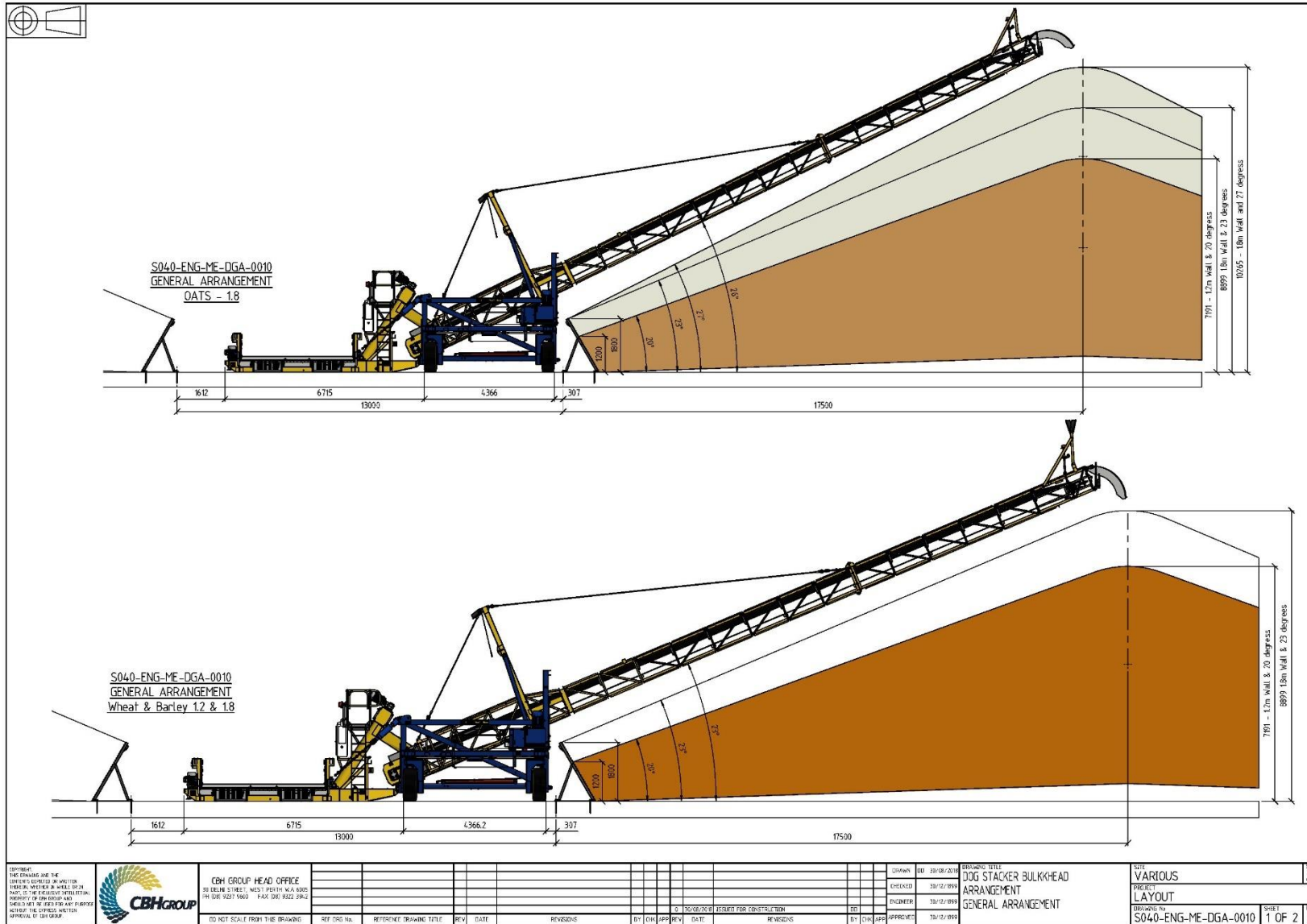

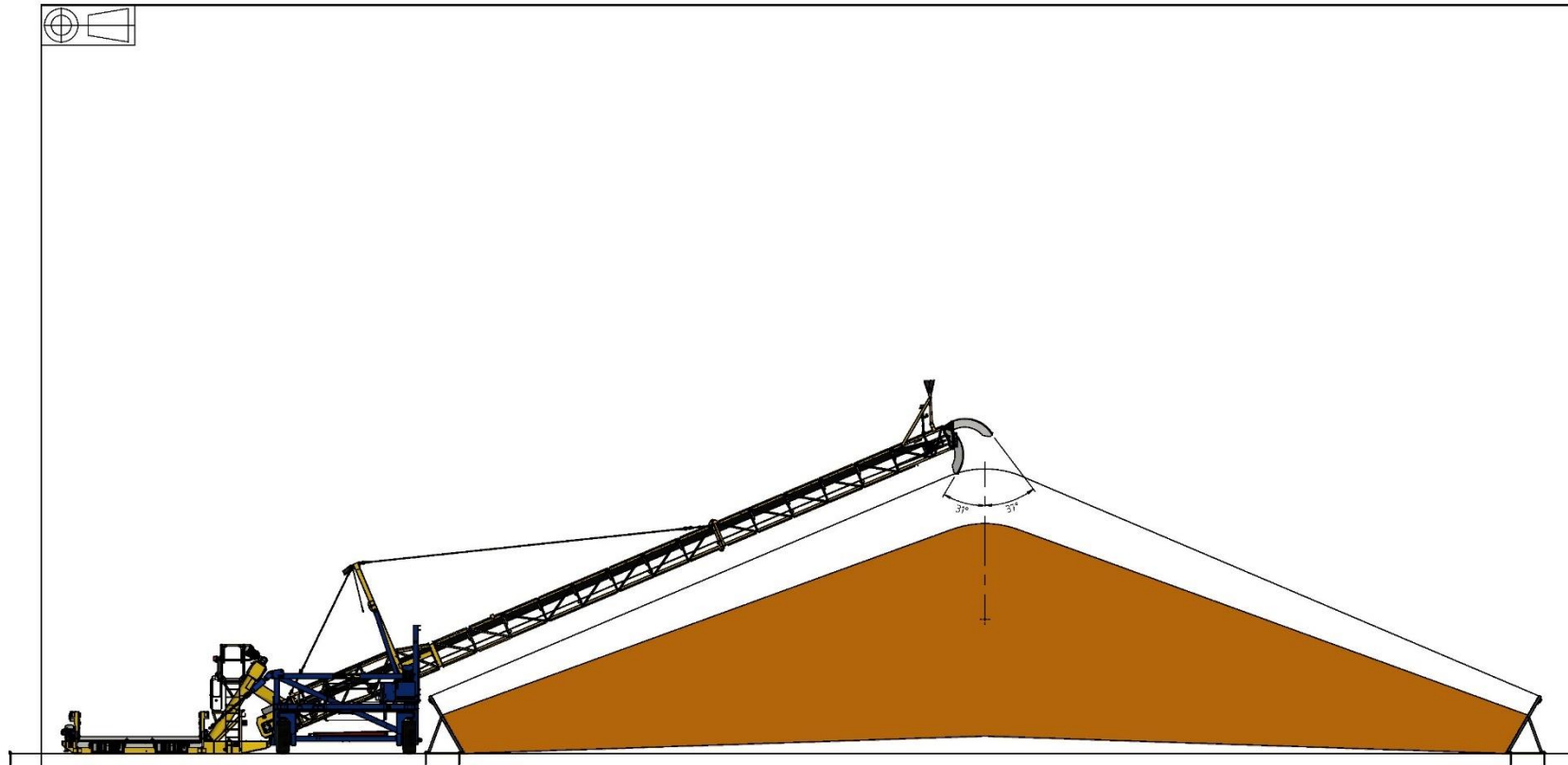

S040-ENG-ME-DGA-0010  
 GENERAL ARRANGEMENT

|  |   |   |  |              |                         |      |      |           |    |     |     |  |           |   |     |  |      |                           |    |     |     |
|--|---|---|--|--------------|-------------------------|------|------|-----------|----|-----|-----|--|-----------|---|-----|--|------|---------------------------|----|-----|-----|
| APPROVED:<br>THE DRAWING AND THE<br>SYSTEMS DESCRIBED IN THIS<br>DRAWING, WHETHER IN WHOLE OR IN<br>PART, IS THE PROPERTY OF CBH GROUP<br>AND SHALL NOT BE USED FOR ANY OTHER<br>PROJECT WITHOUT THE EXPRESS WRITTEN<br>APPROVAL OF CBH GROUP. |  | CBH GROUP HEAD OFFICE<br>35 DEANE STREET, WEST PERTH, W.A. 6150<br>PH (08) 9427 9900 FAX (08) 9422 2962 |  |              |                         |      |      |           |    |     |     | DRAWN: 000 13/08/2018<br>CHECKED: 33/12/1999<br>ENGINEER: 33/12/1999<br>APPROVED: 33/12/1999 |           | DRAWING TITLE<br>DOG STACKER BULKHEAD<br>ARRANGEMENT<br>GENERAL ARRANGEMENT |     | SHEET<br>VARIOUS<br>LAYOUT<br>S040-ENG-ME-DGA-0010 |      | SIZE<br>A1<br>2 OF 2<br>0 |    |     |     |
|  |   | DO NOT SCALE FROM THIS DRAWING  |  | REF. DSG No. | REFERENCE DRAWING TITLE | REV. | DATE | REVISIONS | BY | CHK | APP | DATE   | REVISIONS | BY  | CHK | APP  | DATE | REVISIONS                 | BY | CHK | APP |

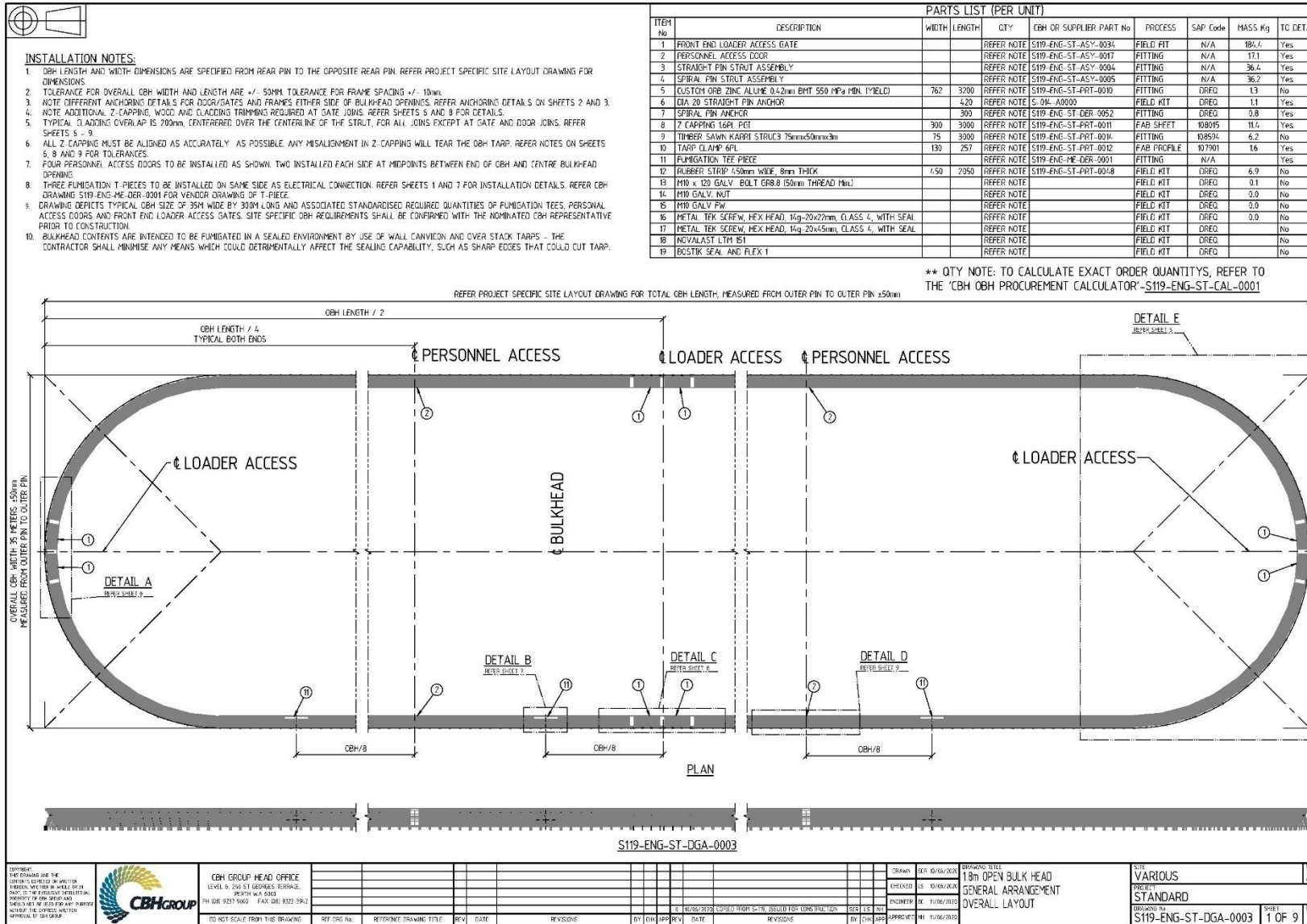

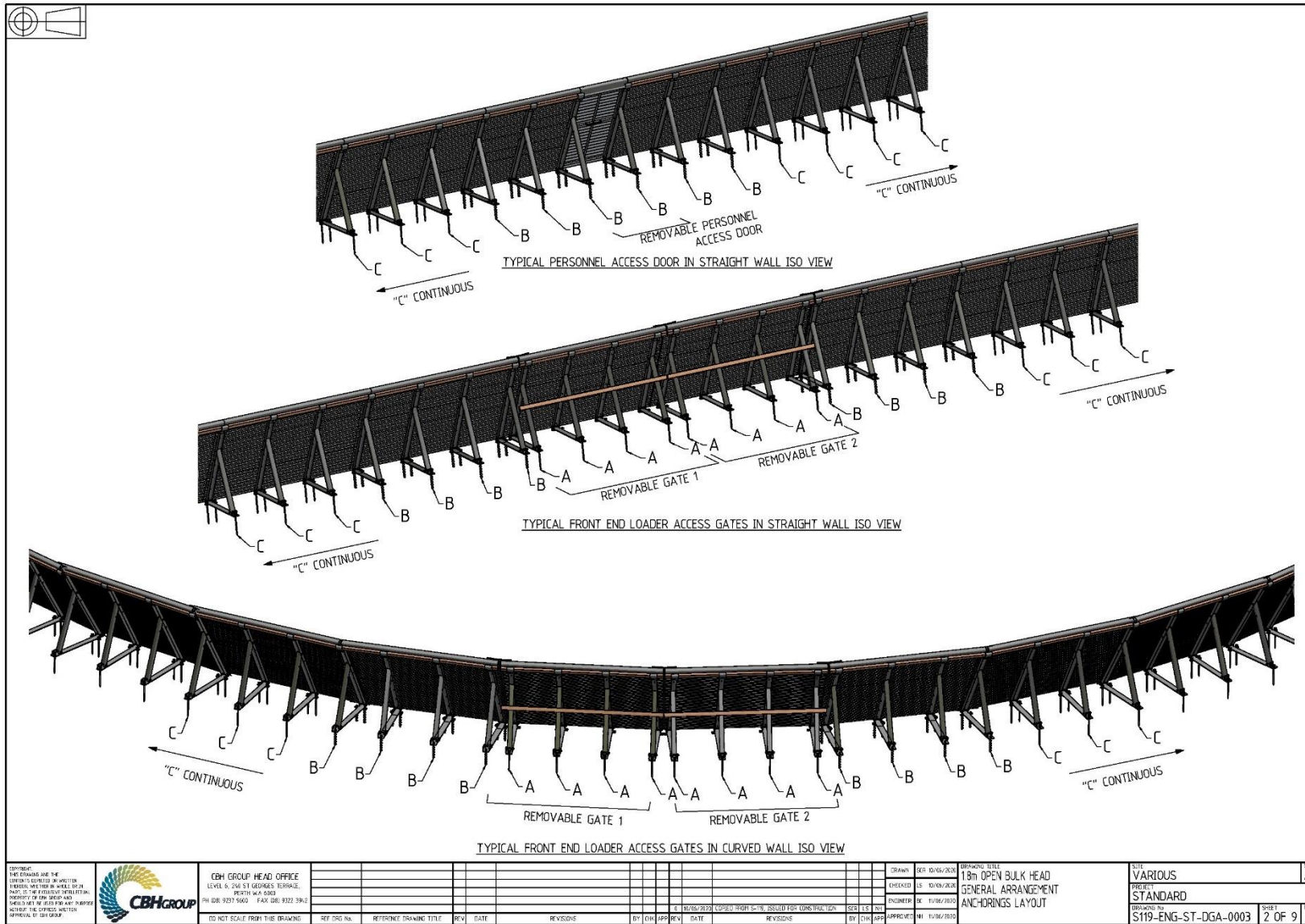

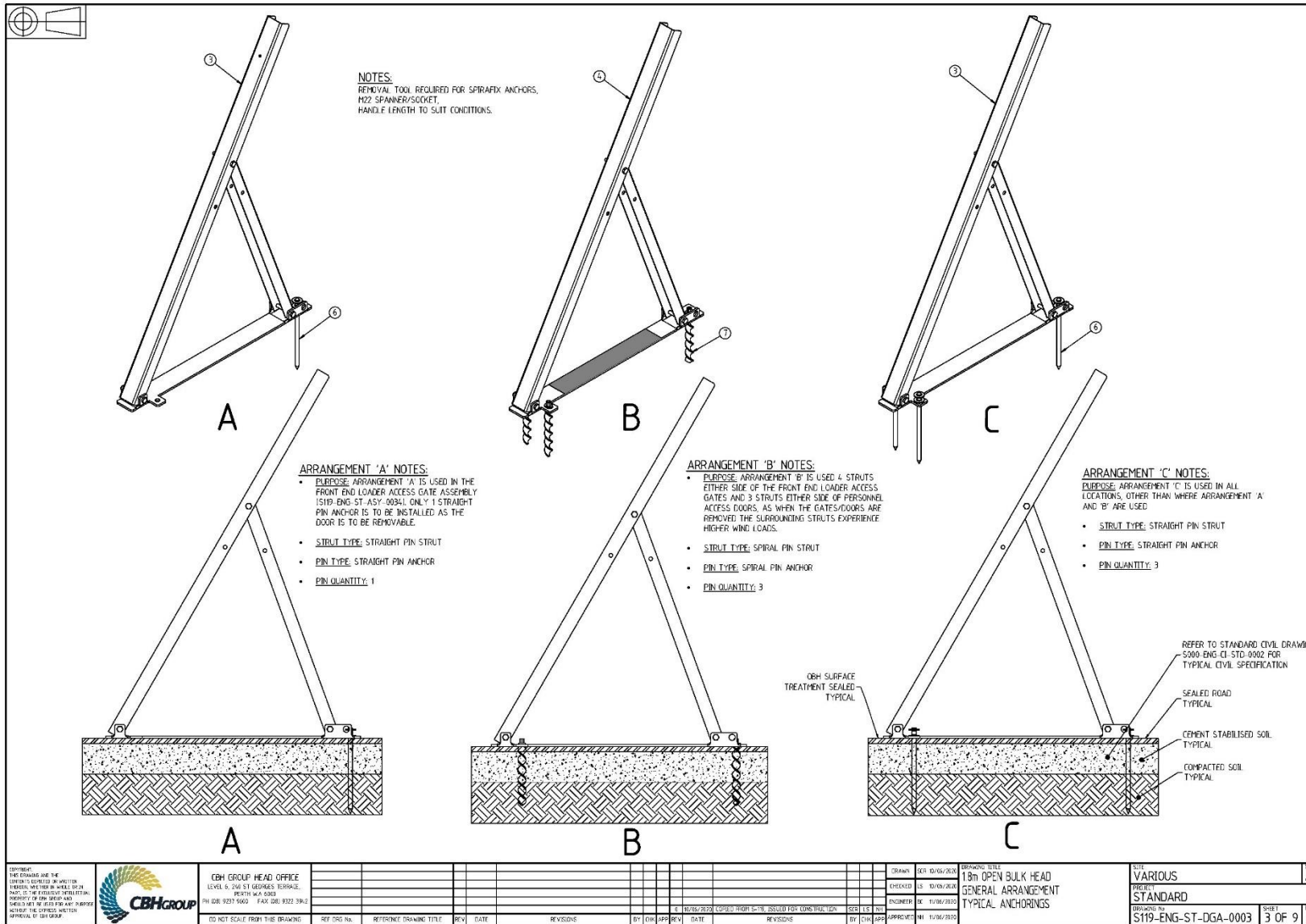

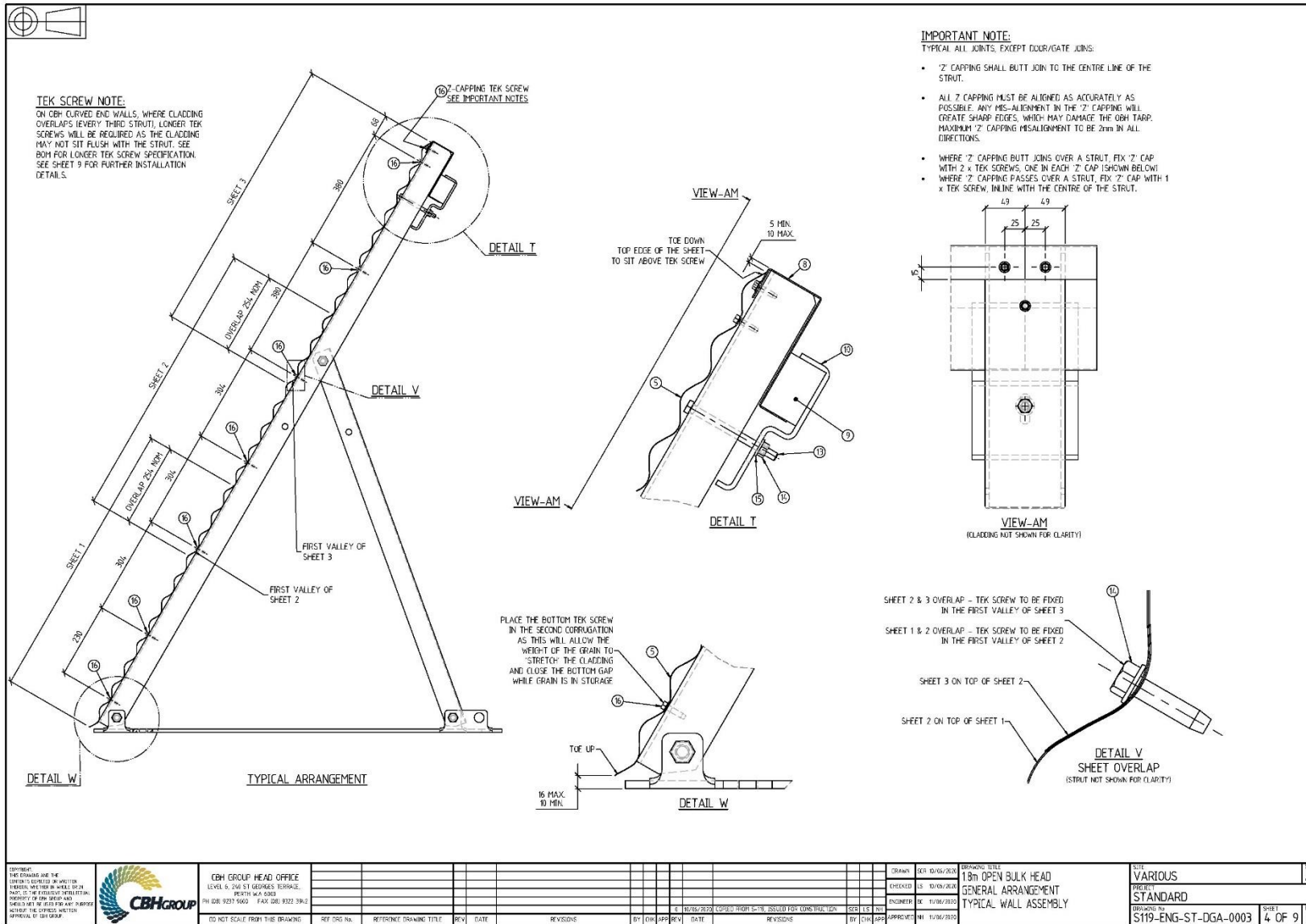

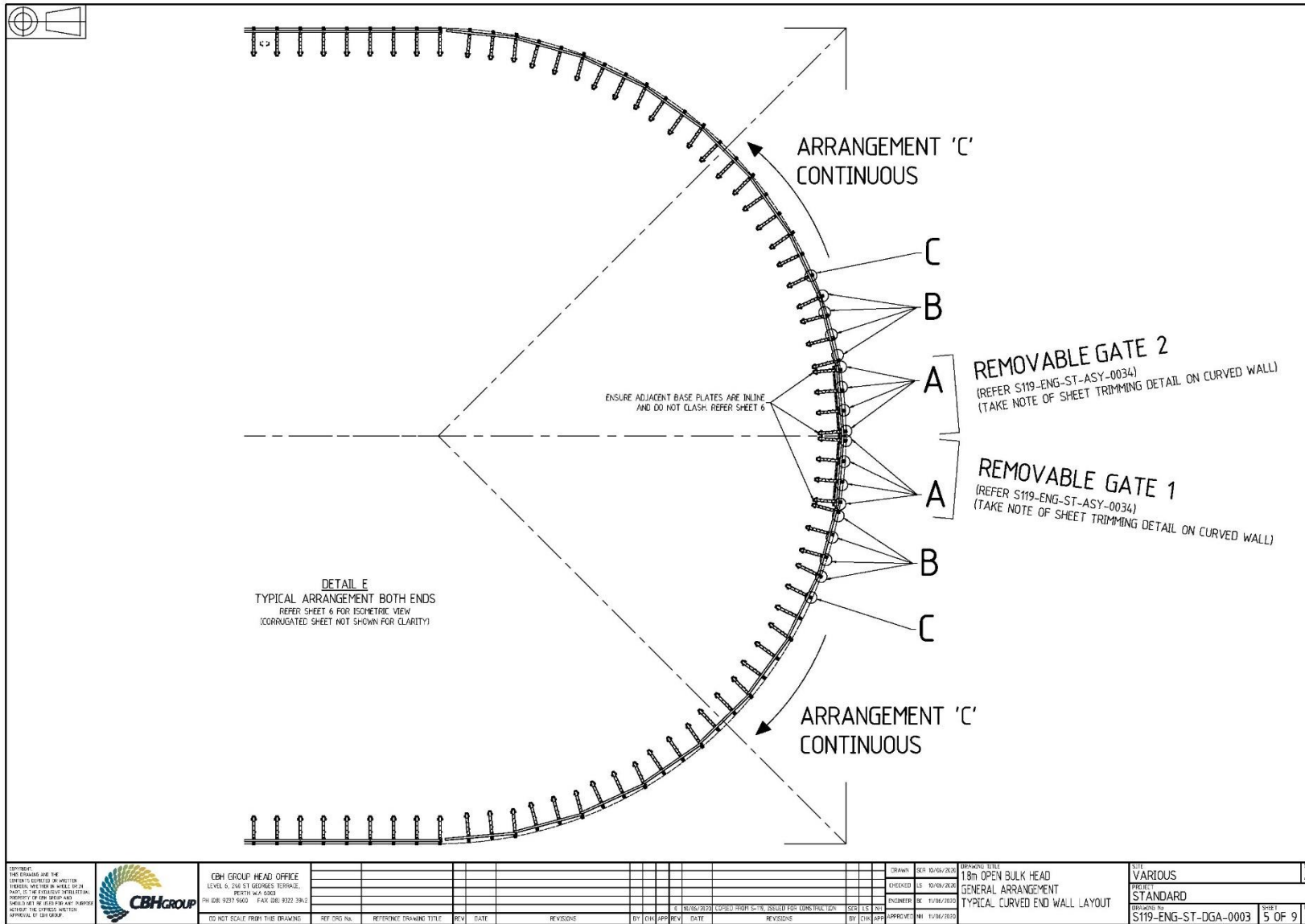

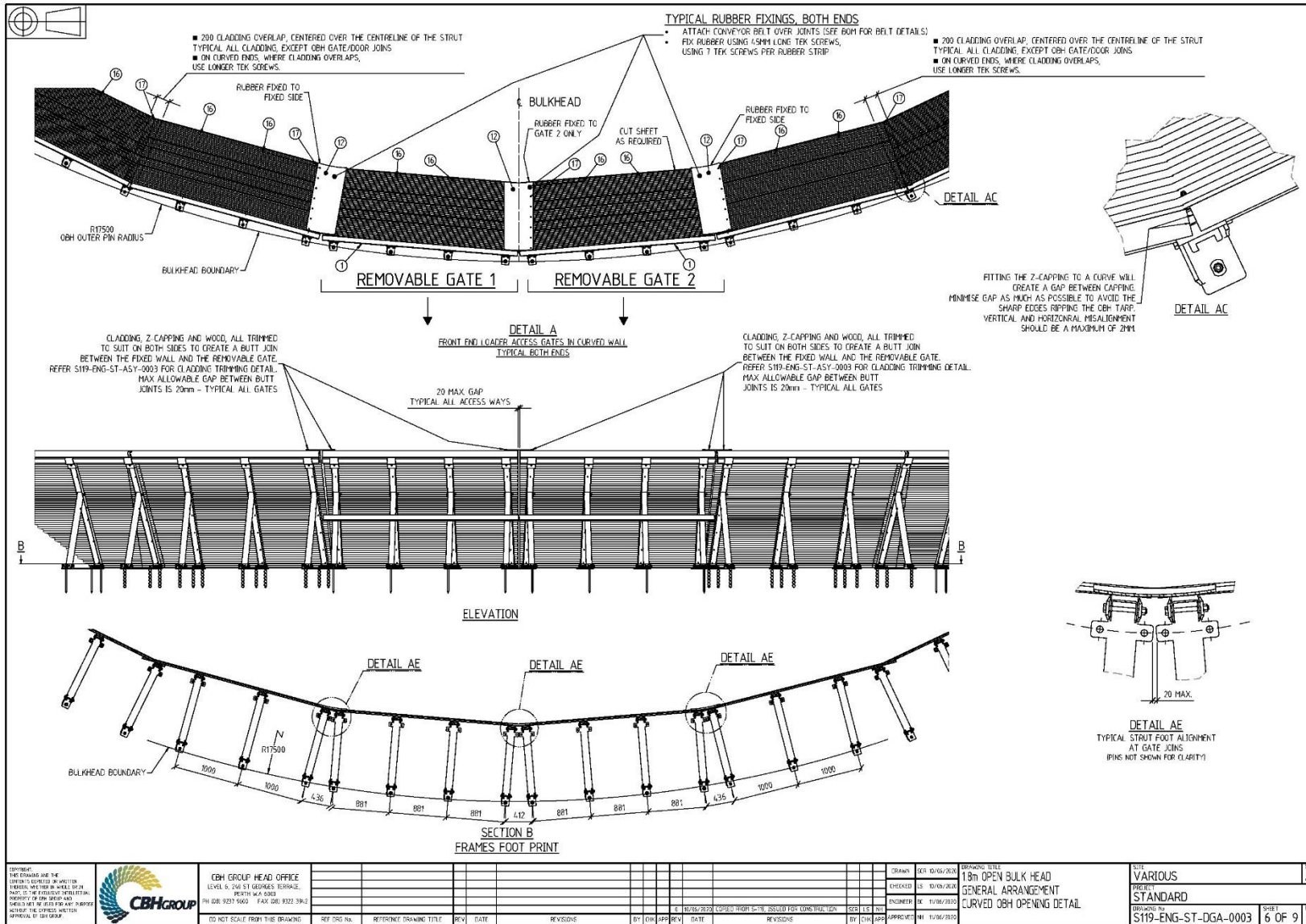



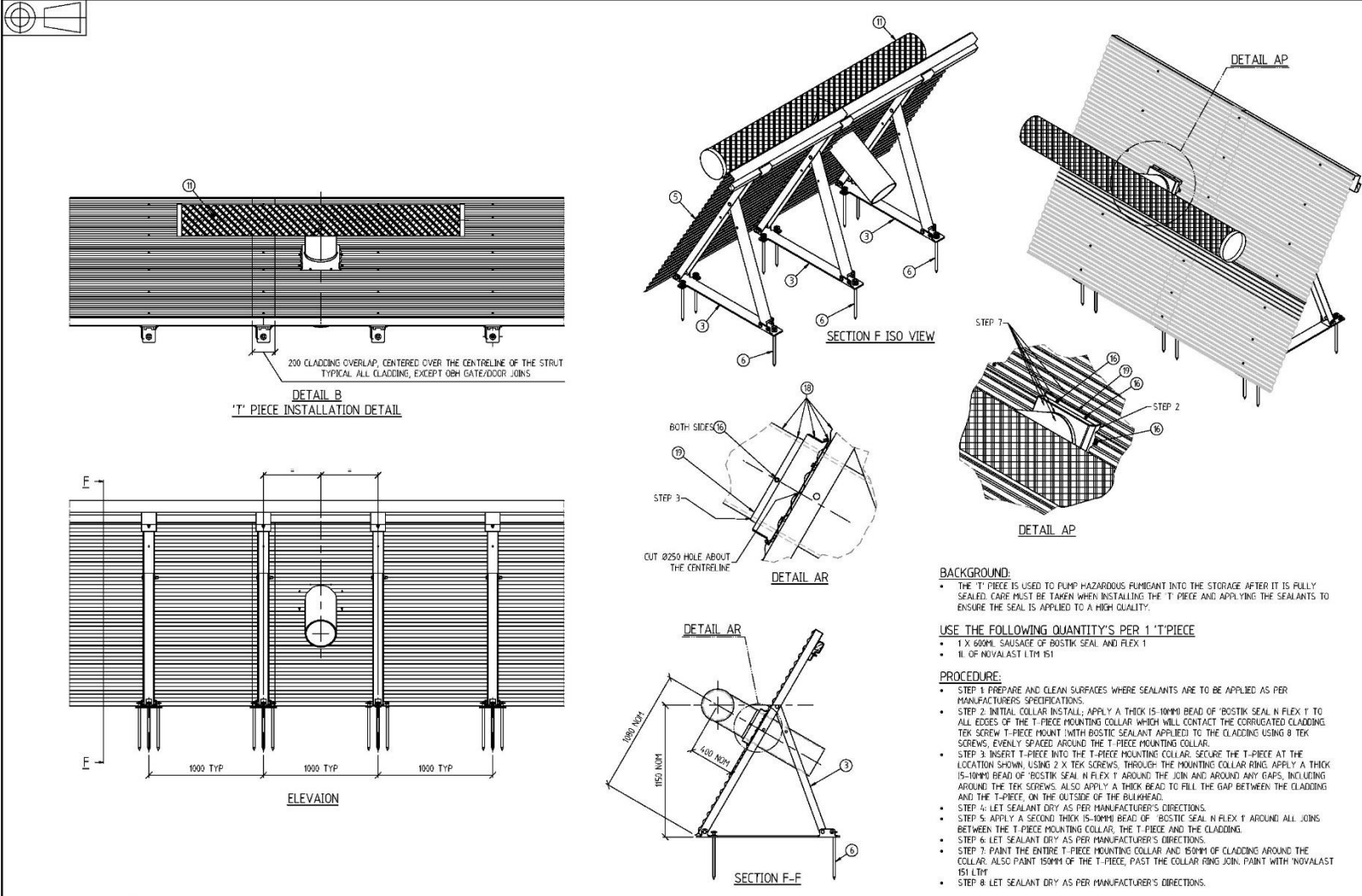

**200 CLADDING OVERLAP, CENTERED OVER THE CENTRELINE OF THE STRUT  
 TYPICAL ALL CLADDING, EXCEPT OBH GATE/DOOR JOINTS**

**DETAIL B  
 'T' PIECE INSTALLATION DETAIL**

**ELEVATION**

**SECTION F ISO VIEW**

**DETAIL AP**

**DETAIL AR**

**SECTION F-F**

**BACKGROUND:**

- THE 'T' PIECE IS USED TO PUMP HAZARDOUS FLUID INTO THE STORAGE AFTER IT IS FULLY SEALED. CARE MUST BE TAKEN WHEN INSTALLING THE 'T' PIECE AND APPLYING THE SEALANTS TO ENSURE THE SEAL IS APPLIED TO A HIGH QUALITY.

**USE THE FOLLOWING QUANTITIES PER 1 'T'PIECE**

- 1 X 600M SAUSAGE OF BOSTIK SEAL AND FLEX 1
- 1L OF NOVALAST LTM 151

**PROCEDURE:**

- STEP 1: PREPARE AND CLEAN SURFACES WHERE SEALANTS ARE TO BE APPLIED AS PER MANUFACTURERS' SPECIFICATIONS.
- STEP 2: INITIAL COLLAR INSTALL: APPLY A THICK 15-10MM BEAD OF BOSTIK SEAL N FLEX 1 TO ALL EDGES OF THE 'T' PIECE MOUNTING COLLAR WHICH WILL CONTACT THE CORRUGATED CLADDING. TEK SCREW 'T' PIECE MOUNT WITH BOSTIK SEALANT APPLIED TO THE CLADDING USING 8 TEK SCREWS, EVENLY SPACED AROUND THE 'T' PIECE MOUNTING COLLAR.
- STEP 3: INSERT 'T' PIECE INTO THE 'T' PIECE MOUNTING COLLAR. SECURE THE 'T' PIECE AT THE LOCATION SHOWN USING 2 X TEK SCREWS THROUGH THE MOUNTING COLLAR RING. APPLY A THICK 15-10MM BEAD OF BOSTIK SEAL N FLEX 1 AROUND THE JOINT AND AROUND ANY GAFFS, INCLUDING AROUND THE TEK SCREWS. ALSO APPLY A THICK BEAD TO FILL THE GAP BETWEEN THE CLADDING AND THE 'T' PIECE, ON THE OUTSIDE OF THE BULKHEAD.
- STEP 4: LET SEALANT DRY AS PER MANUFACTURER'S DIRECTIONS.
- STEP 5: APPLY A SECOND THICK 15-10MM BEAD OF BOSTIK SEAL N FLEX 1 AROUND ALL JOINTS BETWEEN THE 'T' PIECE MOUNTING COLLAR, THE 'T' PIECE AND THE CLADDING.
- STEP 6: LET SEALANT DRY AS PER MANUFACTURER'S DIRECTIONS.
- STEP 7: PAINT THE ENTIRE 'T' PIECE MOUNTING COLLAR AND 150MM OF CLADDING AROUND THE COLLAR. ALSO PAINT 150MM OF THE 'T' PIECE, PAST THE COLLAR RING JOINT. PAINT WITH NOVALAST 151 LTM.
- STEP 8: LET SEALANT DRY AS PER MANUFACTURER'S DIRECTIONS.

**NOTES:**  
 1. THE DRAWING AND THE DATA CONTAINED HEREIN ARE THE PROPERTY OF CBH GROUP AND SHALL REMAIN THE PROPERTY OF CBH GROUP AND SHALL NOT BE REPRODUCED OR TRANSMITTED IN ANY FORM OR BY ANY MEANS, ELECTRONIC OR MECHANICAL, INCLUDING PHOTOCOPYING, RECORDING, OR BY ANY INFORMATION STORAGE AND RETRIEVAL SYSTEM, WITHOUT THE WRITTEN PERMISSION OF CBH GROUP.

**CBH GROUP**

**CBH GROUP HEAD OFFICE**  
 LEVEL 6, 250 ST GEORGES TERRACE,  
 WESTERN HILLS CROSSING  
 PH: 08 9237 5600 FAX: 08 9232 3942

DO NOT SCALE FROM THIS DRAWING

| REV | DATE | BY | CHK | APP | REV | DATE | BY | CHK | APP |
|-----|------|----|-----|-----|-----|------|----|-----|-----|
|     |      |    |     |     |     |      |    |     |     |

|          |            |               |                    |
|----------|------------|---------------|--------------------|
| DATE     | 02/06/2020 | DRAWING TITLE | 18m OPEN BULK HEAD |
| CHECKED  | 13/09/2020 | PROJECT       | STANDARD           |
| ENGINEER | 11/06/2020 | REVISED BY    | 11/06/2020         |
| APPROVED | 11/06/2020 | APPROVED BY   | 11/06/2020         |

PROJECT: S119-ENG-ST-DGA-0003  
 SHEET: 7 OF 9

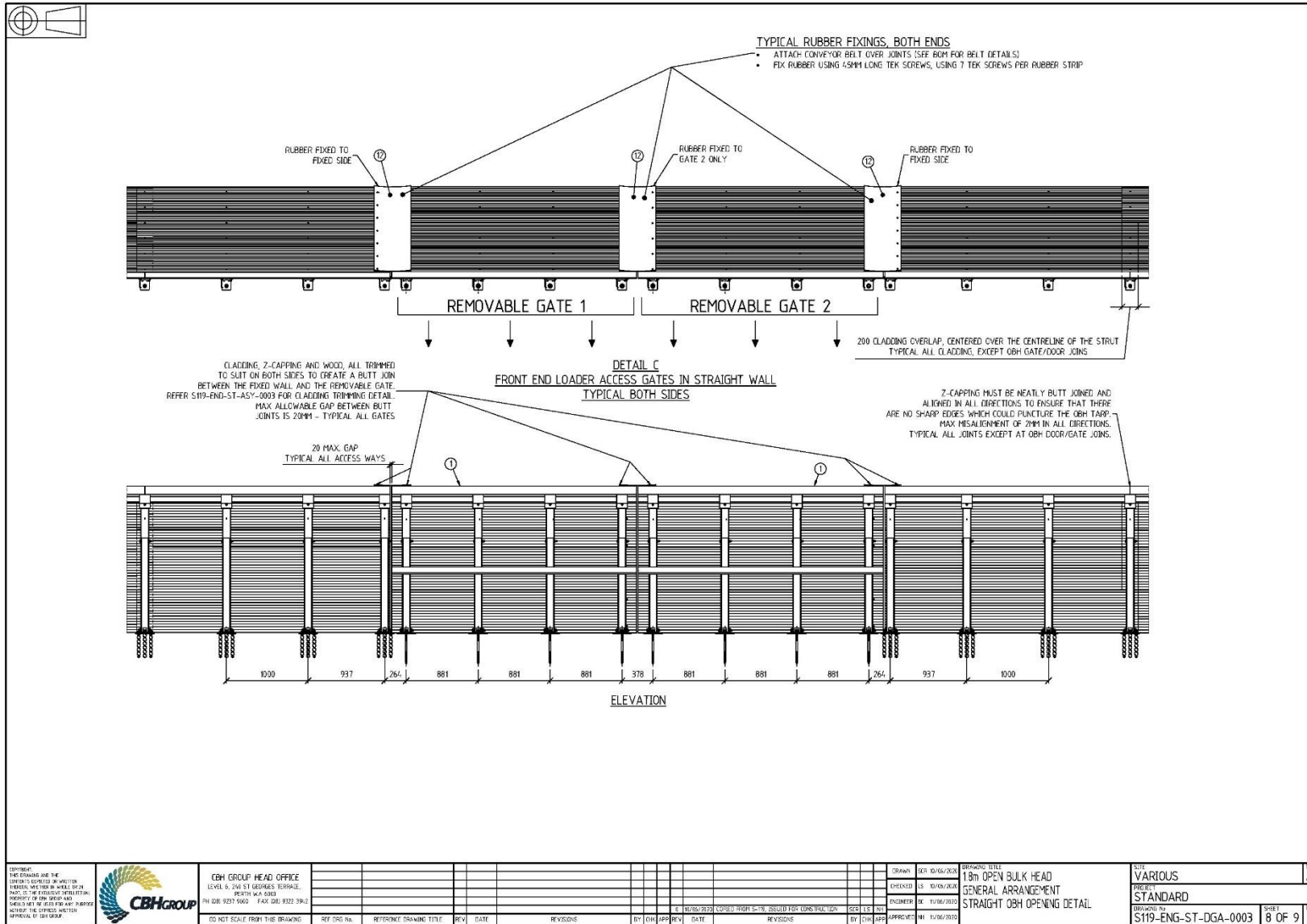

DISCLAIMER: THESE DRAWINGS ARE THE PROPERTY OF CBH GROUP. ANY REUSE OR MODIFICATION WITHOUT THE WRITTEN PERMISSION OF CBH GROUP IS PROHIBITED. THE USER ACCEPTS FULL RESPONSIBILITY FOR THE DESIGN AND CONSTRUCTION OF THE PROJECT AND SHALL BE RESPONSIBLE FOR OBTAINING ALL NECESSARY APPROVALS FROM THE APPROPRIATE AUTHORITIES.



CBH GROUP HEAD OFFICE  
 LEVEL 6, 250 ST GEORGES TERRACE,  
 NORTH WA QLD  
 PH (08) 9327 5600 FAX (08) 9322 3942

| REV | DATE | REVISIONS | BY | CHK | APP | DATE | REVISIONS | BY | CHK | APP | DATE |
|-----|------|-----------|----|-----|-----|------|-----------|----|-----|-----|------|
|     |      |           |    |     |     |      |           |    |     |     |      |

|             |            |                             |                    |
|-------------|------------|-----------------------------|--------------------|
| DESIGNED BY | 10/06/2020 | DESIGNED TITLE              | 18m OPEN BULK HEAD |
| CHECKED BY  | 13/08/2020 | GENERAL ARRANGEMENT         |                    |
| ENGINEER BY | 11/06/2020 | STRAIGHT OBH OPENING DETAIL |                    |
| APPROVED BY | 11/06/2020 |                             |                    |

|            |                      |       |        |
|------------|----------------------|-------|--------|
| SITE       | VARIOUS              | SHEET | A1     |
| PROJECT    | STANDARD             | SHEET | 8 OF 9 |
| DRAWING NO | S119-ENG-ST-DGA-0003 | REV   | 0      |

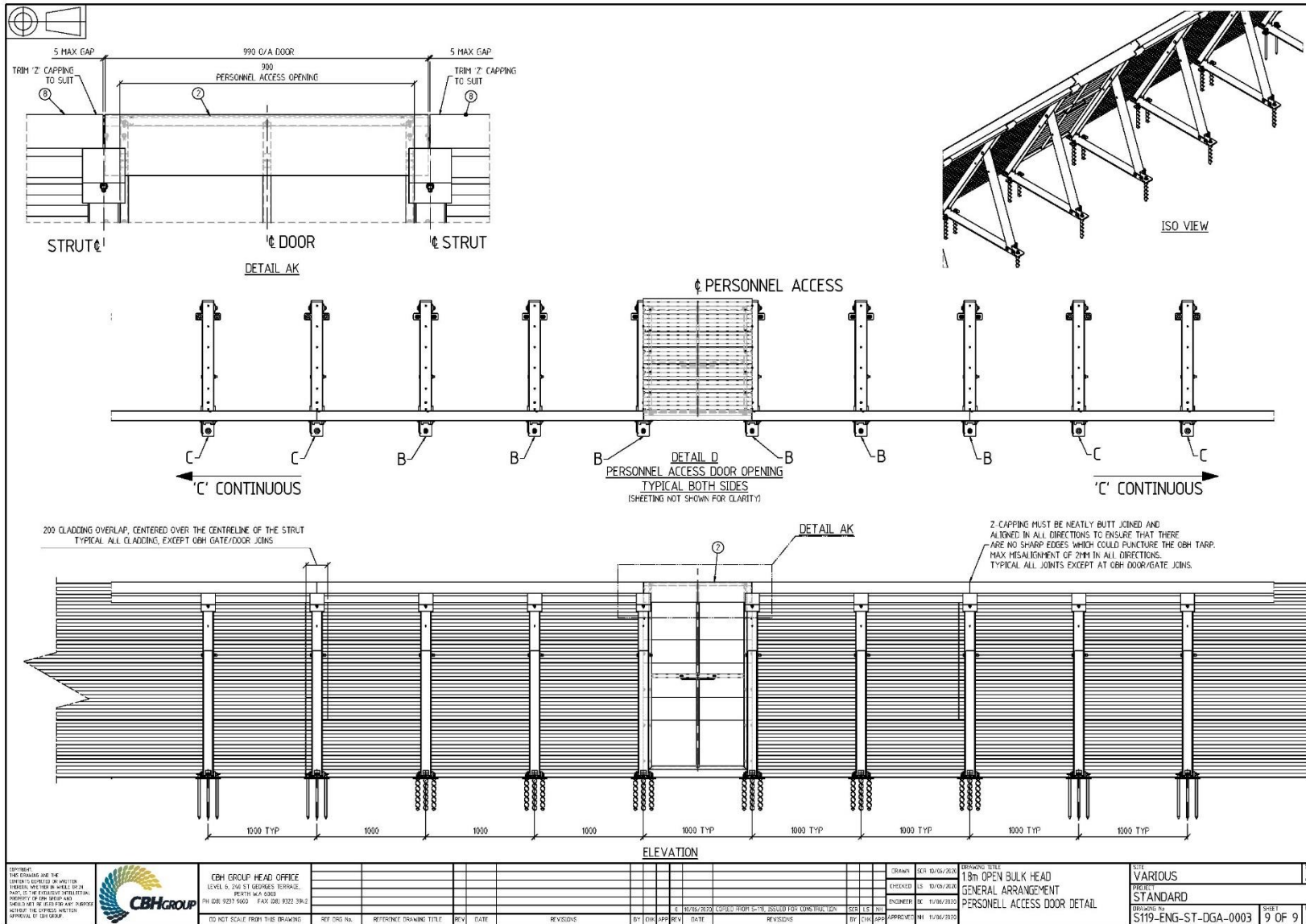



|                        |   |
|------------------------|---|
| Project:               | Meenaar 2022 Emergency Bulkhead<br>Stormwater Management Plan |
| Client:                | CBH   |
| Author:                | R. Needham  |
| Date:                  | 27 <sup>th</sup> July 2022                                    |
| Shawmac<br>Document #: | 2207017-REP-001   |

CONSULTING CIVIL AND TRAFFIC ENGINEERS  
1 ST. FLOOR, 908 ALBANY HIGHWAY, EAST VICTORIA PARK WA 6101.  
PHONE|+61 8 9355 1300  
EMAIL|admin@shawmac.com.au



ISO 9001 QUALITY  
Certified System



Document Status:

| Version | Prepared By | Reviewed By | Approved By | Date     |
|---------|-------------|-------------|-------------|----------|
| A       | R. Needham  | J. Bridge   | R. Needham  | 27/07/22 |
|         |             |             |             |          |
|         |             |             |             |          |
|         |             |             |             |          |
|         |             |             |             |          |
|         |             |             |             |          |

Disclaimer

Although all care has been taken in the preparation of this document, Shawmac Pty Ltd and all parties associated with the preparation of this document disclaim any responsibility for any errors or omissions. Shawmac Pty Ltd reserves the right to amend or change this document at any time. This document does not constitute an invitation, agreement or contract (or any part thereof) of any kind whatsoever. Liability is expressly disclaimed by Shawmac Pty Ltd for any loss or damage which may be sustained by any person acting on this document © Shawmac Pty. Ltd. 2016 ABN 51 828 614 001

File Reference: W:\shaw-sw\NewData\Jobs Active 2022\CE - Roads and Drainage\CBH - Meenaar Emergency Bulkhead\_2207017\3. Documents\3.3 Design Report\SWMP\2207017-REP-001.docx





## Contents

|      |   |    |
|------|---|----|
| 1.   | Introduction .....                              | 4  |
| 1.1. | The Project .....                               | 4  |
| 1.2. | Purpose .....                                   | 4  |
| 1.3. | History .....                                   | 5  |
| 2.   | Pre-developed Situation .....                   | 6  |
| 2.1. | General .....                                   | 6  |
| 2.2. | Site Characteristics .....                      | 6  |
| 2.3. | Topography .....                                | 6  |
| 2.4. | Geotechnical .....                              | 7  |
| 2.5. | Environmental .....                             | 8  |
| 2.6. | Catchment and Surface Water Flows .....         | 8  |
| 3.   | Stormwater Management Strategy .....            | 10 |
| 3.1. | Strategy Overview .....                         | 10 |
| 3.2. | Design Criteria and Modelling Assumptions ..... | 10 |
| 3.3. | Stormwater Quantity .....                       | 12 |
|      | Appendix A – CBH Concept Plan .....             | 13 |

## Figures

|           |   |   |
|-----------|---|---|
| Figure 1: | Meenaar Site .....                            | 4 |
| Figure 2: | Pre-developed Site Characteristics .....      | 6 |
| Figure 3: | Existing Topography .....                     | 7 |
| Figure 4: | Catchment Areas and Surface Water Flows ..... | 9 |



---

**Tables**

Table 1: Existing Catchment Flow Rates..... 9

Table 2: Basin Details..... 12



## 1. Introduction

### 1.1. The Project

CBH are in the process of planning for an emergency specification open Bulkhead (OBH) expansion to their existing Meenaar site to be delivered before the 2022 harvest. The Meenaar site is located within the Avon Industrial Park, approximately 20km east of the existing CBH Avon site, along Great Eastern Highway (GEH).

The Meenaar site has been operating in a temporary manner for one year, after CBH constructed 6x emergency bulkheads on the site ahead of the 2021 harvest.

The 2022 emergency OBH expansion involves the construction of three new bulkheads (TBH 07,08 and 09) to provide 1231,140t of storage. Refer to **Appendix A – CBH Concept Plan** which shows the proposed bulkhead areas.

**Figure 1** shows the general location of the Meenaar site.



Figure 1: Meenaar Site

### 1.2. Purpose

The purpose of this report is to outline and quantify the proposed stormwater management measures to be





adopted for the emergency bulkhead construction. This SWMP has been prepared ahead of detailed designs for the bulkhead construction and will be utilised to guide the future design work.

### 1.3. History

Shawmac previously prepared a Stormwater Management Plan to support the 2021 emergency expansion. Refer to document 2106010-REP-005. The 2021 SWMP identified the stormwater management measures to be adopted for the previous emergency bulkhead construction. In general, these included:

- Maintaining the two existing discharge points from the site.
- Installation of 2x new drainage basins just upstream of each site discharge point to compensate post-development outflow rates to pre-developed levels for up to the 5-year ARI event.
- The basins were designed to be free-draining (i.e. with an outlet at base level) so that they would empty between design events.
- Design of internal open drains and culverts in accordance to CBH's emergency bulkhead design criteria for up to the 5-year ARI event.

Although the 2021 SWMP proposed that the basins were to be free draining, they were not constructed this way. The reason behind this is not known, but may be due to a common Shire requirement to retain stormwater drainage on site.



## 2. Pre-developed Situation

### 2.1. General

For the purpose of this SWMP, the pre-developed descriptions will mainly reflect the situation prior to construction of the 2021 emergency bulkheads. Both the 2021 and 2022 emergency constructions seek to replicate the pre-developed situation as far as practical.

### 2.2. Site Characteristics

The pre-developed site was vacant and cleared of almost all significant vegetation. The site is bound by Leeming Road to the south, railway and Great Eastern Highway to the north, industrial development to the east and farmland to the west. The site is generally featureless except for a sand quarry located in the central northern part of the site and a number of rock outcrops throughout the site.

Error! Reference source not found. shows an aerial image of the pre-developed site.



Figure 2: Pre-developed Site Characteristics

### 2.3. Topography

Figure 3 shows the topography (2m contours) of the site and its immediate surrounds, as well as the 2021



emergency bulkhead construction. The site is undulating, and ranges in height from approximately 226m AHD along the eastern boundary to 251m AHD in the central northern area. A ridge in the northern part of the site and saddle in the southern portion results in the land falling to the north, east and southwest. The typical gradients are in the order of 1.5% to 7%.



Figure 3: Existing Topography

#### 2.4. Geotechnical

Galt Geotechnics undertook a geotechnical investigation of the site in July 2021 which involved excavation of 6 test pits at depths ranging from 1.0m to 2.9m. Galt described the subsurface conditions generally as follows:

- Northern portion (TBH05/06):
  - Thin layer of topsoil over variable thickness gravelly soil (gravelly sand/sandy gravel) and residual to extremely weathered rock (sandy clay to clay) to the maximum investigated depth of 2.3m.
- Balance of site:
  - Thin layer of topsoil over residual to extremely weathered rock. The weathered rock varies significantly between Sandy Clay/Clay, Clayey Sand and gravelly soils.



A previous geotechnical investigation was undertaken by GHD in September 2010 for the entire Avon Industrial Park. GHD described the soils the of the site as generally consisting of a layer of topsoil over residual and extremely weathered granitic gneiss soil, overlying granite gneiss bedrock. Localised yellow sand and gravelly sand/sandy gravel were encountered in the proximity of the existing quarry, with the thickness of sandy material ranging from 0.9m to 2.7m depths. Several rock outcrops were identified throughout the site.

Permeability tests were undertaken by GHD which indicated the permeability of the site soils range from 0.08m/day to 0.1 m/day. GHD advised that stormwater disposal through infiltration is not recommended.

## 2.5. Environmental

The site is almost completely cleared of natural vegetation and there is little environmental value within the site. The northern and eastern portion of the site fall towards Grass Valley Brook on the northern side of Great Eastern Highway. Grass Valley Brook combines with Mortlock River and then Avon River at Northam. The south western portion of the site falls towards an unnamed creek which traverses through farm land and connects to Mortlock River approximately 5km south east of the site.

## 2.6. Catchment and Surface Water Flows

Based on the location of the proposed OBH's and the existing topography, the site can be divided into two catchments. Catchment 'A' is located over the western portion of the site and discharges towards a culvert underneath Leeming Road which outfalls into the creek line running south to Mortlock River. Part of the adjacent farm to the west of the CBH site also contributes to this outlet. Catchment 'B' is located over the eastern portion of the site and discharges towards a creek line which flows into culverts under the railway, Great Eastern Highway and then Grass Valley Brook.

The proposed TBH07 is situated on the boundary between Catchment 'A', 'B' and the external catchment which falls north towards the railway line and Great Eastern Highway. CBH's design standards (open drains) will result in all runoff from TBH07 being directed to Catchment 'A' or 'B'. Given that the area of TBH07 within the external catchment is negligible in comparison to the overall catchment, the external catchment will be excluded from further assessment.



Figure 4: Catchment Areas and Surface Water Flows

The existing catchments were assessed using ARR's (2001) Index Flood Method. **Table 1** below shows the estimated pre-existing flow rates for various Average Recurrence Intervals.

Table 1: Existing Catchment Flow Rates

| Catchment | 2 year                | 5 year                | 10 year               | 20 year               | 50 year               |
|-----------|-----------------------|-----------------------|-----------------------|-----------------------|-----------------------|
| A         | 0.30m <sup>3</sup> /s | 0.62m <sup>3</sup> /s | 1.14m <sup>3</sup> /s | 2.01m <sup>3</sup> /s | 3.79m <sup>3</sup> /s |
| B         | 0.18m <sup>3</sup> /s | 0.38m <sup>3</sup> /s | 0.69m <sup>3</sup> /s | 1.22m <sup>3</sup> /s | 2.30m <sup>3</sup> /s |



### 3. Stormwater Management Strategy

#### 3.1. Strategy Overview

The proposed stormwater management strategy is identical to that adopted for the 2021 emergency bulkhead construction, including construction of the basins to not be free draining (i.e. without a low level culvert outlet). Note that the basin design parameters described in the 2021 SWMP reflect a free draining scenario. For this 2022 SWMP, the basin design parameters are much more onerous to reflect the increase catchment area for the site expansion as well as the removal of the low level culvert outlets.

Similar to the 2021 construction, the proposed overall drainage strategy primarily involves the retention of the two existing discharge points. Basin's 'A' and 'B' will be located just upstream of these locations and will be sized to CBH's design criteria to retain the entirety of the critical 5-year event. For events greater than this, the basins will overtop towards the existing discharge points. Typically, for Meenaar, the critical 5-year event (24 hours) of 54.8mm represents 78% of the average rainfall received in the month of July (70.1 mm).

The proposed OBH's and other infrastructure areas are almost entirely located within either Catchment 'A' or 'B' and accordingly, the earthworks designs will seek to maintain the existing catchment boundaries and overall areas as far as practical, and to direct runoff from the entire infrastructure area to one of the basins.

There is a small area of the northern part of the bulkheads (TBH07) that sits just outside the Catchment 'A' or 'B' boundary. This is a portion of land on the northern side of the natural ridge which falls to the north. This area will be captured in the open drains and directed to the two drainage basins to prevent uncontrolled runoff towards the north. This will require the basins to be slightly larger by proportion due to the change in catchment area.

As the site has poor infiltration characteristics and no low level outfall, the basins will start to fill after the first rains and drain very slowly, if at all. It is possible that the basin will fill and leave insufficient capacity for further rainfall events, then overtop towards the existing flow paths. There is risk of scour and transport of sediments occurring to the downstream land should the basins overtop. Provision will be made for this, through the construction of a controlled weir outfall from the basin and installation of loose rock to reduce velocities and promote sheet flow, but it should be noted that these measures are not 100% effective and ongoing monitoring and some repair work are likely to be required.

It is understood that after service life, CBH either decommission the basin and emergency bulkheads (and restore the site to its original conditions) or implement a permanent drainage solution in line with the planned permanent expansion of Meenaar site.

#### 3.2. Design Criteria and Modelling Assumptions

Based on the adopted strategy and CBH's emergency bulkhead design specifications, the key stormwater



management design criteria are summarised as follows:

- The existing internal and external catchments should retain their current flow paths through to the existing site discharge points as far as practical.
- The basin is to be sized for the critical 5-year event, with no outfall and a 300mm freeboard.
- The basin, open drains and culverts are to be sized for the 5-year ARI event in accordance with CBH requirements.
- A nominal 100mm/day infiltration rate has been assumed to reflect some seepage and evaporation.
- The basins should have provision for a controlled weir overflow and scour protection measures.
- Open drains are to be set at a minimum 300mm deep below the bottom of pavement, or 600mm below surface where no pavement is to be installed.
- Culvert headwater heights are to be limited to a maximum 300mm below shoulder surface level.
- Culverts may have a minimum 400mm cover.
- Minimum drain fall of 0.3% in accordance with CBH requirements.
- No scour protection (likely problem areas (>2m/s velocity to be highlighted), except for basin outlets.

A preliminary XPSTORM model has been built for the proposed works. The following key assumptions were utilised:

- Infiltration losses were assumed as 15mm from pervious areas. Nil losses were assumed for impervious areas.
- Rainfall intensities and temporal patterns are consistent with ARR 2019.
- Mannings 'n' value of 0.03 was assumed for open drains, to allow lower construction tolerances and some vegetation growth.
- The temporary OBH's are assumed to be impervious, and runoff occurs in one direction, consistent with the earthworks design. Note that when the tarping is installed runoff from half the OBH will fall in the opposite direction. The open drains have been checked for capacity under these conditions.



### 3.3. Stormwater Quantity

**Table 2** and Error! Reference source not found. provide summaries of the modelling outcomes of the basins and culverts, respectively. All results reflect the 5-year event.

**Table 2: Basin Details**

| Item                                 | Basin A | Basin B |
|--------------------------------------|---------|---------|
| Base Level (m AHD)                   | 228.70  | 229.66  |
| Base Area (m <sup>2</sup> )          | 5,000   | 8,800   |
| Top Level (m AHD)                    | 230.50  | 231.16  |
| Top Area (m <sup>2</sup> )           | 6,000   | 9,800   |
| Max Volume (m <sup>3</sup> )         | 9,900   | 13,500  |
| TWL (m AHD)                          | 230.19  | 230.81  |
| Freeboard (m)                        | 0.31    | 0.35    |
| Max Stored Volume                    | 8,083   | 10,695  |
| Max Outflow Rate (m <sup>3</sup> /s) | -       | -       |

Culvert and open drains have not been modelled in detail at this stage. These designs will be finalised in conjunction with the detailed earthworks designs, consistent with the design criteria outlined in the previous section of this report.





---

**Appendix A – CBH Concept Plan**

---

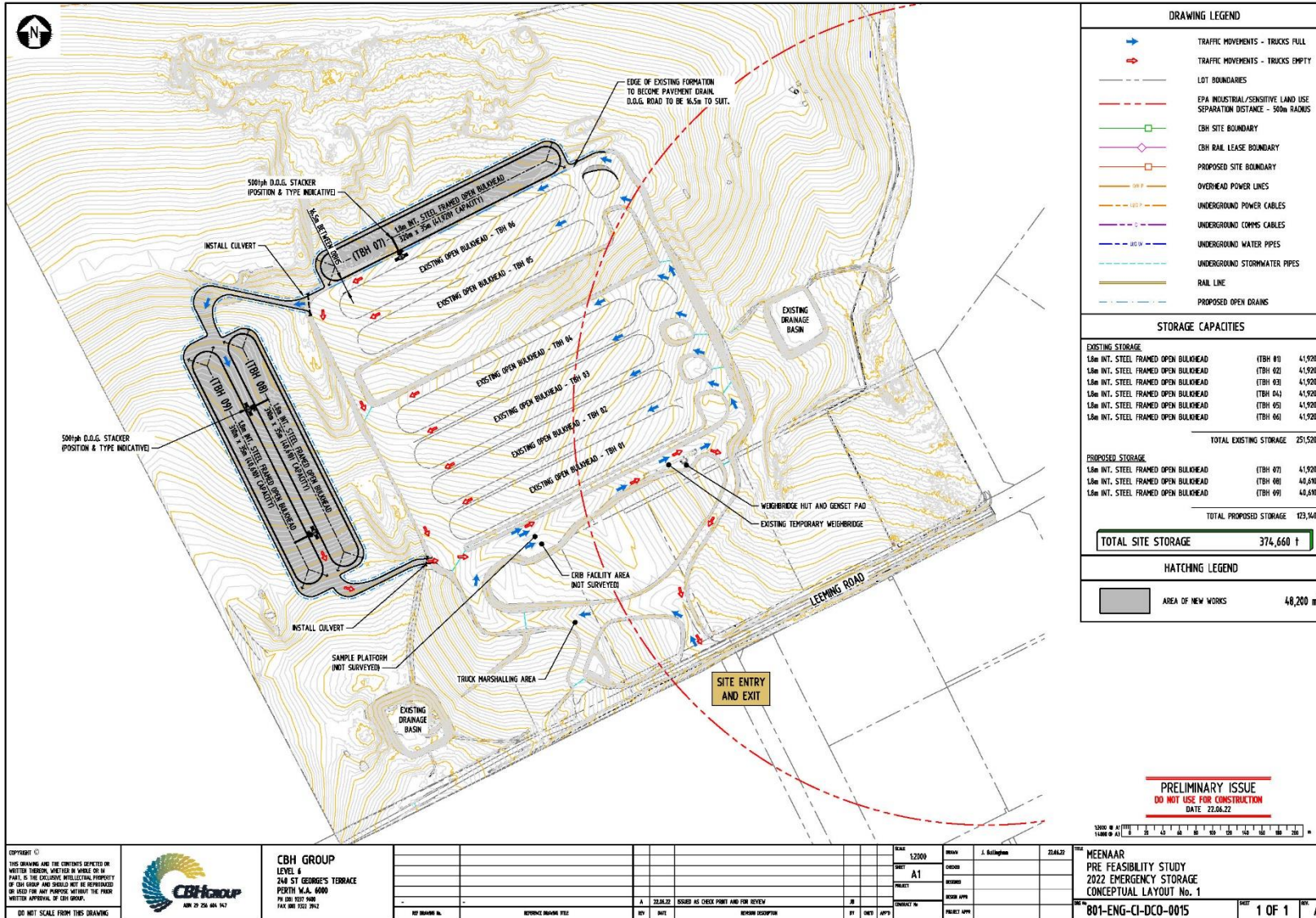



|                     |                            |
|---------------------|----------------------------|
| Project:            | Meenaar Emergency OBH's    |
| Client:             | CBH                        |
| Author:             | J. Bridge                  |
| Date:               | 27 <sup>th</sup> July 2022 |
| Shawmac Document #: | 2207017-TIS-001            |

CONSULTING CIVIL AND TRAFFIC ENGINEERS  
1 ST. FLOOR, 308 ALBANY HIGHWAY, EAST VICTORIA PARK WA 6101.  
PHONE +61 8 9355 1300  
EMAIL [admin@shawmac.com.au](mailto:admin@shawmac.com.au)



ISO 9001 QUALITY  
Certified System



Document Status: Client Review

| Version | Prepared By | Reviewed By | Approved By | Date     |
|---------|-------------|-------------|-------------|----------|
| A       | J. Bridge   | R. Needham  | J. Bridge   | 27.07.22 |
|         |             |             |             |          |
|         |             |             |             |          |
|         |             |             |             |          |
|         |             |             |             |          |
|         |             |             |             |          |

Disclaimer

Although all care has been taken in the preparation of this document, Shawmac Pty Ltd and all parties associated with the preparation of this document disclaim any responsibility for any errors or omissions. Shawmac Pty Ltd reserves the right to amend or change this document at any time. This document does not constitute an invitation, agreement or contract (or any part thereof) of any kind whatsoever. Liability is expressly disclaimed by Shawmac Pty Ltd for any loss or damage which may be sustained by any person acting on this document © Shawmac Pty. Ltd. 2016 ABN 51 828 614 001

File Reference: Y:\Jobs Active 2022\ICE - Roads and Drainage\CBH - Meenar Emergency Bulkhead\_2207017\3. Documents\3.6 TIS\2207017-TIS-001 RevA.docx



## Contents

|        |   |    |
|--------|---|----|
| 1.     | Introduction .....                                | 1  |
| 1.1.   | Background.....                                   | 1  |
| 2.     | Existing Situation.....                           | 2  |
| 2.1.   | Road Network.....                                 | 2  |
| 2.2.   | Speed Limit.....                                  | 2  |
| 2.3.   | Carriageway Width and Cross Section .....         | 3  |
| 2.4.   | Traffic Volumes .....                             | 4  |
| 2.5.   | RAV Status .....                                  | 6  |
| 2.6.   | Crash History .....                               | 8  |
| 2.7.   | Changes to Surrounding Transport Networks.....    | 8  |
| 3.     | Traffic Generation .....                          | 9  |
| 3.1.   | Development Details .....                         | 9  |
| 3.2.   | Haulage Vehicle.....                              | 9  |
| 3.3.   | Operating Hours and Reveal Period.....            | 9  |
| 3.4.   | 5-year Average Traffic Data.....                  | 9  |
| 3.5.   | Predicted Traffic without Emergency OBH.....      | 10 |
| 3.6.   | Predicted Traffic with Emergency OBH.....         | 10 |
| 3.7.   | Haulage Route.....                                | 11 |
| 3.8.   | Peak Period Assessment.....                       | 11 |
| 4.     | Traffic Impact Assessment.....                    | 13 |
| 4.1.   | Assessment Years.....                             | 13 |
| 4.2.   | Impact on Roads.....                              | 13 |
| 4.2.1. | Road Minimum Widths.....                          | 13 |
| 4.3.   | Road Safety.....                                  | 13 |
| 4.4.   | Safe Intersection Sight Distance – Site Exit..... | 13 |
| 4.5.   | Entering Sight Distance – Site Exit.....          | 16 |



---

|                                      |    |
|--------------------------------------|----|
| 5. Conclusions .....                 | 17 |
| Appendix A – CBH Concept Plan.....   | 18 |
| Appendix B – Traffic Count Data..... | 19 |



## Figures

|  |    |
|--|----|
| Figure 1: Site Location.....                                     | 1  |
| Figure 2: Road Hierarchy Layout.....                             | 2  |
| Figure 3: MRWA Speed Limit of Surrounding Road Network.....      | 3  |
| Figure 4: Traffic Count Location.....                            | 5  |
| Figure 5: RAV Status - Tandem Drive Network.....                 | 7  |
| Figure 6: RAV Status - Tri Drive Network.....                    | 7  |
| Figure 7: MRWA Crash report mapping.....                         | 8  |
| Figure 8: Typical Tandem Drive RAV7.....                         | 9  |
| Figure 9: Peak Daily / Hour Volumes (CBH Only).....              | 12 |
| Figure 10: Looking East Along Leeming Road from Site Access..... | 14 |
| Figure 11: Looking West Along Leeming Road from Site Access..... | 15 |
| Figure 12: Site Access SISD.....                                 | 15 |

## Tables

|  |    |
|--|----|
| Table 1: Road Configuration.....                       | 3  |
| Table 2: Daily Traffic Volumes (Monday to Friday)..... | 4  |
| Table 3: Peak Hour Traffic Volumes.....                | 4  |
| Table 4: Harvest Truck Movement Comparison.....        | 11 |
| Table 5: Rural Road Minimum Width.....                 | 13 |
| Table 6: SISD at Site Access.....                      | 16 |
| Table 7: RAV Vehicle Entering Sight Distance.....      | 16 |



## 1. Introduction

### 1.1. Background

CBH are proposing to construct emergency open bulkheads (TBH) at their existing Meenaar site in preparation for the 2022 harvest. It is proposed to construct three new emergency TBH's (TBH 07,08,09) with 123,140t capacity which will utilise the existing site access/exit and marshal/sample/weigh facilities.

Shawmac have been commissioned to prepare a Traffic Impact Statement assessing the impacts of the proposed emergency OBH storage on the surrounding road network.

**Figure 1** shows the existing site and location of the proposed emergency TBH's. Refer to **Appendix A – CBH Concept Plan** for full details of the proposal.

The emergency TBH's are anticipated to be in place for one year only.

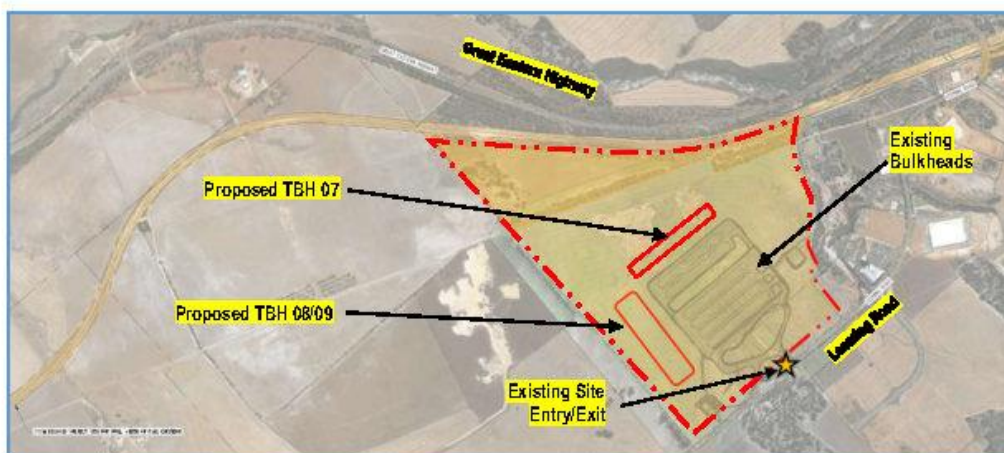

Figure 1: Site Location





## 2. Existing Situation

### 2.1. Road Network

The layout and hierarchy of the existing road network according to the Main Roads Western Australia (MRWA) Road Information Mapping System is shown in **Figure 2**.

As shown, Leeming Road is classified as an Access Road.

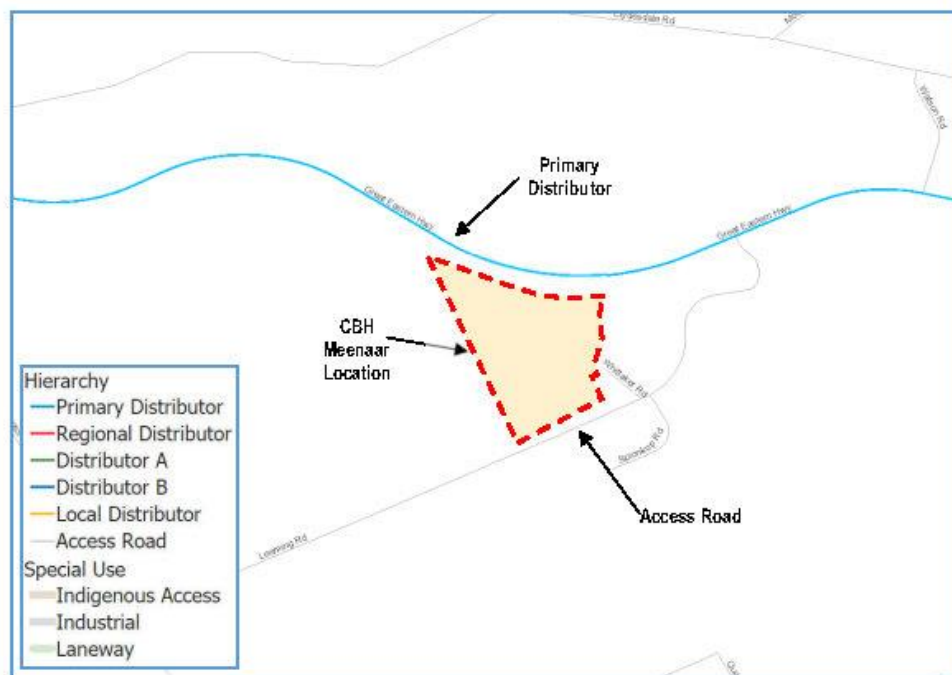

Figure 2: Road Hierarchy Layout

### 2.2. Speed Limit

As per MRWA's Road Information Mapping System, Leeming Road has a posted speed limit of 50 km/h. **Figure 3** shows the speed zoning of the surrounding road network.

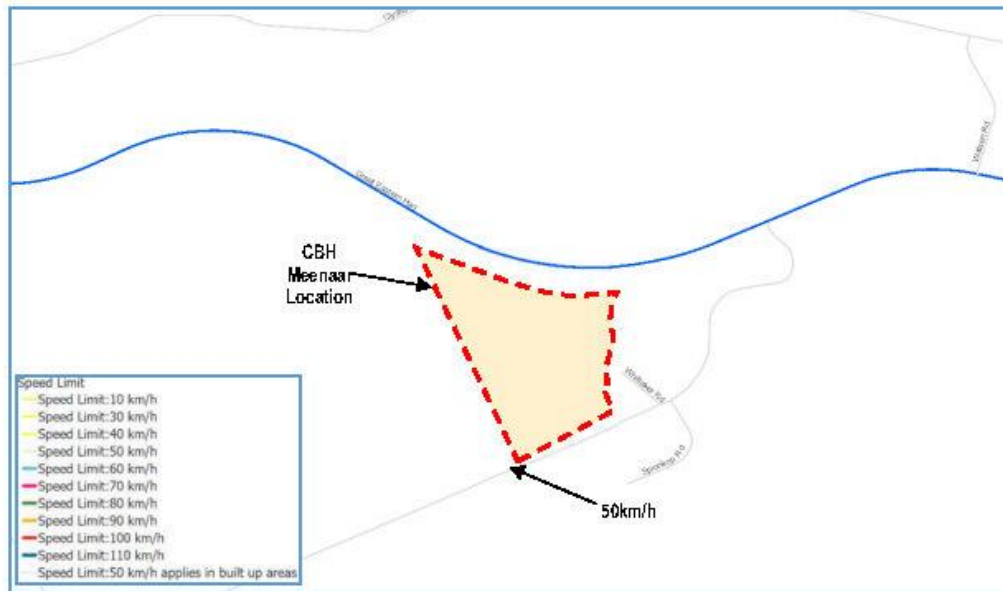

Figure 3: MRWA Speed Limit of Surrounding Road Network

### 2.3. Carriageway Width and Cross Section

The carriageway and configuration of the relevant adjacent roads are summarised in **Table 1**.

Table 1: Road Configuration

| Road and Location | Road Type   | Cross Section               | Carriageway Width (Approx.) | Sealed Pavement Width (Approx.) |
|-------------------|-------------|-----------------------------|-----------------------------|---------------------------------|
| Leeming Road      | Access Road | Two-lane single carriageway | 9.5-10m                     | 8.2-8.5m                        |

The above measurements were taken from survey previously provided by CBH.



## 2.4. Traffic Volumes

The latest traffic volumes for Leeming Road were obtained from MRWA Traffic map as summarised in **Table 2** and **Table 3**.

As shown in **Figure 4**, the traffic count is located north of the CBH site and the pre-existing developed industrial area. In addition, the CBH site is at the end of the sealed section of Leeming Road where there is expected to be negligible public traffic as there is a closed gate restricting public and CBH access from the unsealed section of Leeming Road. Therefore, the traffic volumes along Leeming Road fronting the CBH site are expected to be much lower than the traffic count volumes. For conservatism, the traffic count volumes have been adopted for the existing traffic fronting the CBH site/ In addition, it is assumed that the traffic count volumes did not include any CBH traffic.

Considering the conservative approach mentioned above for assessing existing traffic fronting the CBH site, an annual growth factor has not been applied to the 2020/21 volumes and are considered suitable for the purpose of the 2022/23 assessment.

Detailed traffic count data is attached in **Appendix A**.

**Table 2: Daily Traffic Volumes (Monday to Friday)**

| Road                   | Location                                 | Daily Volume | Data Source |
|------------------------|--|--------------|-------------|
| Leeming Road (4211128) | South of Great Eastern Highway (SLK 4.4) | 147          | MRWA 20/21  |

**Table 3: Peak Hour Traffic Volumes**

| Road / Direction | Location                       | AM Peak | PM Peak | HV% |
|------------------|--------------------------------|---------|---------|-----|
| Leeming Road NB  | South of Great Eastern Highway | 7       | 16      | 22% |
| Leeming Road SB  | South of Great Eastern Highway | 15      | 5       |     |



Figure 4: Traffic Count Location



## 2.5. RAV Status

As per MRWA HVS network mapping tool:

- Leeming Road (East of Site access)
  - Categorised under the Tandem Drive RAV 7.3 and Tri Drive 1.3 network with the following conditions.
  - Maximum speed 70km/h.
  - All operators must carry current written approval from the road asset owner permitting use of the road.
- Leeming Road (West of Site access)
  - Categorised under the Tandem Drive RAV 3.1 and Tri Drive 1.1 network with the following conditions.
  - Maximum speed 40km/h.
  - All Operators must carry current written approval from the road asset owner permitting use of the road. No Operation on unsealed road segment when visibly wet, without road owner's approval.

**Figure 5** and **Figure 6** shows the Tandem Drive and Tri-Drive network along Leeming Road.

It is noted the RAV status along Leeming Road varies and the classification changes from Tandem Drive 7.3 to 3.1 and Tri Drive 1.3 to 1.1. The maximum trucks able to access Leeming Road are RAV 7 trucks up to the site access.

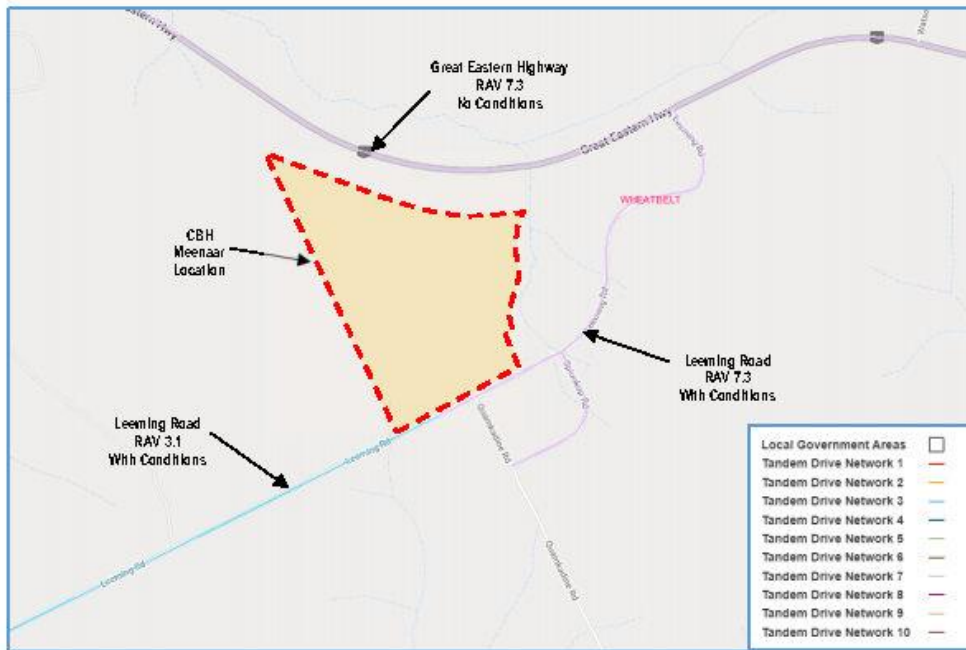

Figure 5: RAV Status - Tandem Drive Network

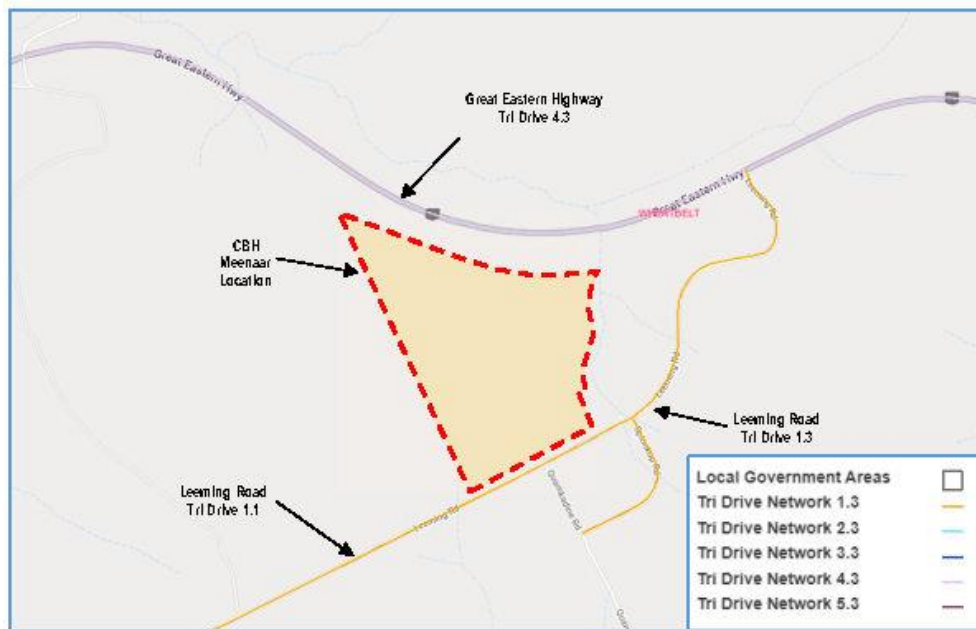

Figure 6: RAV Status - Tri Drive Network



## 2.6. Crash History

Crash data for the relevant roads in the vicinity of the site was sourced from MRWA Crash Analysis Reporting System (CARS) for the 5-year period ending 31/12/2021. This is shown in **Figure 7**.

Only one crash has been recorded along Leeming Road. The crash occurred on 13/01/2021 and involved a head on collision involving two vehicles. The severity is listed as "Property damage only".

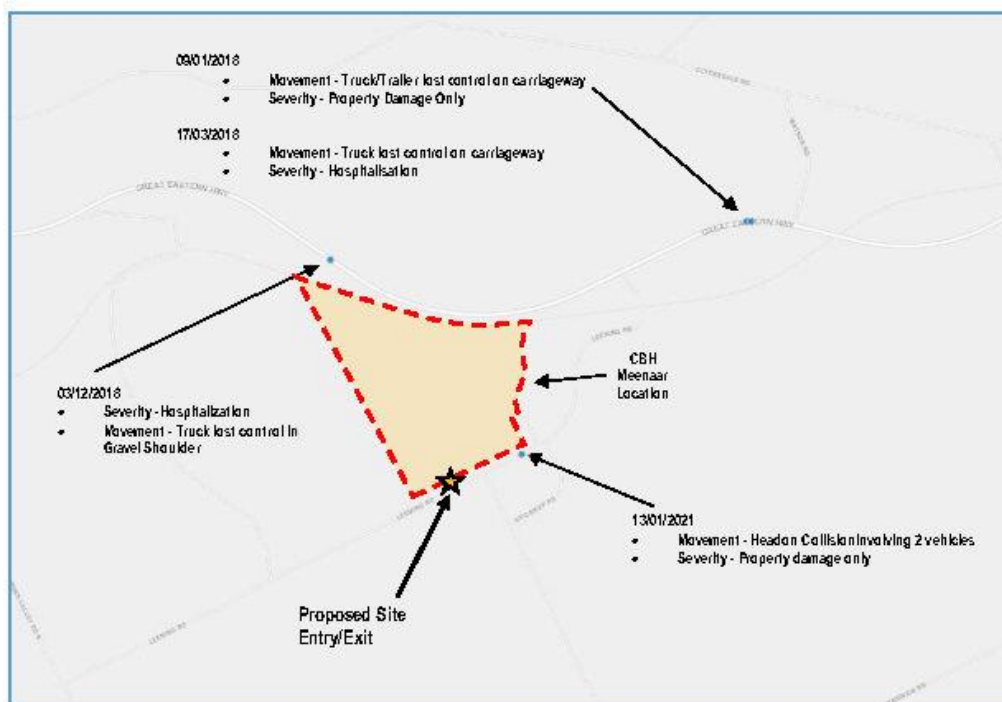

Figure 7: MRWA Crash report mapping

## 2.7. Changes to Surrounding Transport Networks

There are no known changes to the adjacent network that have the potential to affect the assessment. It is understood that in the medium term, it is likely that the intersection of Leeming Road and Great Eastern Highway will be upgraded, however this is outside the planned timeframe for the operation of the emergency bulkheads.



### 3. Traffic Generation

#### 3.1. Development Details

CBH propose to construct three new temporary TBH's to provide a total nameplate storage capacity of 123,140t. This will increase the total site storage capacity from 251,520t to 374,660t.

CBH have advised that the nameplate capacity is seldom able to be achieved. This is because of "loss by division/loss by commodity" where multiple grain types are required to be stored/tarped within the same TBH, resulting in less efficient storage. CBH have advised that maximum effective storage capacity for this site is generally around 94% of nameplate i.e., there is 6% lost due to loss by division/loss by commodity inefficiency. The effective existing storage capacity would therefore be 236,429t, increasing to 352,180t after construction of the emergency TBH.

However, CBH note that at present there is a large volume of "carry-over" grain at many sites including Meenaar. This is grain that, due to logistical constraints, has not been able to be removed from sites and exported prior to the upcoming harvest. This has left many sites, including Meenaar with a shortfall in capacity, and needing emergency storage to be built.

#### 3.2. Haulage Vehicle

It is proposed to use RAV7 trucks up to 36.5m long for the transport of grain. **Figure 8** shows a typical RAV7 vehicle. In addition, CBH also noted that while this site is rated for RAV7, deliveries would include haulage using RAV4 or even as low as RAV1 vehicles.



Figure 8: Typical Tandem Drive RAV7

#### 3.3. Operating Hours and Reveal Period

The campaign period for reveal of grains will start mid-October and last 2-3 months. It is noted that the amount of daily reveal varies depending on the supply.

CBH propose to operate the site 12 hours a day (6 AM to 6 PM) and Monday to Sunday with minor variations of start and finish times.

#### 3.4. 5-year Average Traffic Data

The Meenaar Site has only been in operation since last year's harvest (2021/22). Therefore, CBH have only last year's traffic data as follows:





- 2021/22 receivals – 109,597t
- Average truck payload – 50.1t
- Origin direction split – 12.77% north, 4.03% south, 43.95% east, 39.25% west.

The traffic / receival data indicates that the site is currently not being loaded to full capacity. However, given the significant harvest this year, CBH is anticipating an increase in received tonnes to the site (compared to last year). In addition, CBH note that at present there is a large volume of "carry-over" grain at many sites including Meenaar. This is grain that, due to logistical constraints, has not been able to be removed from sites and exported prior to the upcoming harvest. Therefore, although the entire Meenaar site provides a significant amount of storage, well over last year's receivals, it is understood that a large portion of this is not available for receivals.

### 3.5. Predicted Traffic without Emergency OBH

CBH are proposing to construct the emergency TBH's to increase site capacity so that more grain can be stored through the harvest and inefficient out loading movements within the harvest period are avoided.

During the harvest, once site capacity is reached, out loading movements may be required to restore capacity and allow grain to continue to be received from the nearby farms. This will involve shifting the grain from Meenaar to the next available site with storage capacity, with movement occurring towards the export port. This double-handling of grain is inefficient in terms of cost and adds additional traffic to the surrounding road network.

For comparative purposes it is useful to assess what would occur if the proposed emergency bulkheads are not constructed.

CBH expect that the 2022/23 harvest receivals will exceed the available capacity of the site by approximately the volume of the planned emergency storage. This would result in receivals of approximately 115,752t (123,140t x 94% efficiency). Based on the average truck payload of 50.1t, this would result in an additional 2,310 truck movements within the harvest period for out loading.

Note that for the purposes of this assessment a single 'movement' is defined as a round trip i.e. the site entry/delivery and site exit/return home comprise one movement.

If the emergency TBH is constructed, then the 2,310 truck movements still need to occur to move the grain for export, but this would occur outside the harvest period, when there are less trucks on the road network.

### 3.6. Predicted Traffic with Emergency OBH

Regardless of whether the emergency OBH's are built, the same higher than average delivery movements to the Meenaar site will occur during the harvest. The effect of constructing the emergency storage is that out loading movements during the busy harvest period are eliminated.

CBH expect that the 2022/2023 harvest will result in approximately 231,021t of grain being transported to the



Meenaar Site however, due to previous years of “carry-over” grain, it is understood that there is only 115,270t of storage available for receivals. Based on the average payload of 50.1t, **Table 4** provides an estimate of the 22/23 harvest period truck movements, with and without the proposed emergency OBH and with comparison to the current available storage.

**Table 4: Harvest Truck Movement Comparison**

|  | 2021/22<br>Receivals | 22/23 Without<br>Emergency OBH | 22/23 With<br>Emergency OBH |
|--|----------------------|--------------------------------|-----------------------------|
| Tonnes Received (t)                    | 109,597              | 231,021                        | 231,021                     |
| Truck Payload (t)                      | 50.1                 | 50.1                           | 50.1                        |
| Total Harvest Receival<br>Movements    | 2,188                | 4,611                          | 4,611                       |
| Total Harvest Out<br>Loading Movements |                      | 2,310                          | -                           |
| Total Harvest<br>Movements             | 2,188                | 6,922                          | 4,611                       |

As shown, the movements for 2022/2023 regardless of the emergency TBH construction are expected to exceed the existing capacity and last year's truck movements, but the construction of the emergency TBH allows movements to be reduced in comparison to the scenario where the emergency TBH is not installed for the 2022/2023 harvest.

### 3.7. Haulage Route

All trucks will enter and leave the CBH site via the existing access/exit off Leeming Road. CBH anticipate that the site catchment will result in the following movement directional split:

- North – 12.77%
- South – 4.03%
- East – 43.95%
- West – 39.25%

Based on the road network and given the condition and low RAV status of Leeming Road (west of the proposed site access, which access is also closed off by a gate, it is assumed that 100% of movements will entire the site from a right turn off Leeming Road and all vehicles will access the site from Great Eastern Highway.

### 3.8. Peak Period Assessment

Although the harvest period is expected to occur over a period of approximately 2-3 months, it is known that there is a peak within this period. Specific data for Meenaar was not available to define this peak period, but data from other CBH sites indicate that generally 80-85% of grain is received within 28 days.

For the purposes of assessing the peak period impacts, the following assumptions have been made:



- 85% of total grain tonnes are received within, and evenly distributed over 28 days.
- Truck deliveries occur over a 12-hour period, and 10% of all daily volumes are received within a peak hour.

Based on these assumptions:

- 3,920 truck movements will occur during the 28-day peak.
- 140 movements will occur each day of the 28-day peak.
- 14 movements will occur during a peak hour.

Figure 9 shows the peak daily / hourly movement volumes based on the previously discussed traffic distribution. Note that figures have been rounded up to the nearest whole number.

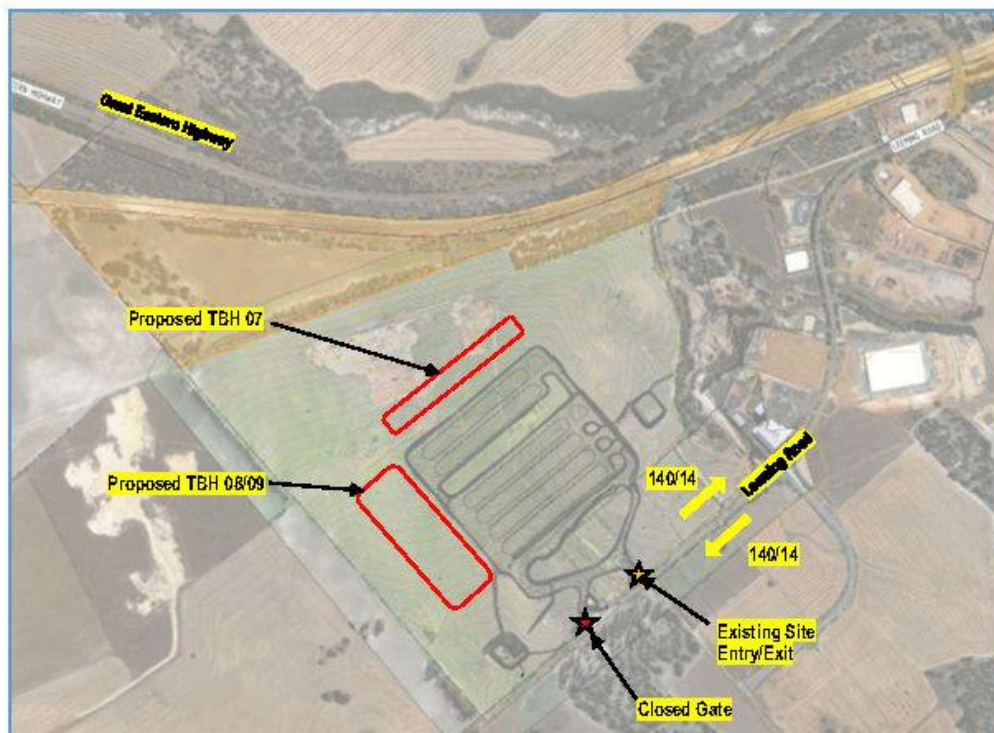

Figure 9: Peak Daily / Hour Volumes (CBH Only)



## 4. Traffic Impact Assessment

### 4.1. Assessment Years

The development is assessed based on current network condition (2022).

### 4.2. Impact on Roads

#### 4.2.1. Road Minimum Widths

The sealed widths of the surrounding roads were checked against the Rural Road Minimum Width in accordance with Appendix A of the MRWA RAV assessment guideline. The comparison is shown below in **Table 5**.

Table 5: Rural Road Minimum Width

| Road         | Location                       | Existing AADT | Proposed AADT (Peak) | Speed (RAV) | RAV Status | Required Minimum Seal / Carriageway | Existing Sealed / Carriageway Width |
|--------------|--------------------------------|---------------|----------------------|-------------|------------|-------------------------------------|-------------------------------------|
| Leeming Road | South of Great Eastern Highway | 147           | 287                  | 50km/h      | 7.3        | 5.7m/7.7m                           | 8.2-8.5m / 9.5-10m                  |

As shown, the minimum widths all comply

### 4.3. Road Safety

The crash history of the adjacent road network (as previously outlined in **Section 2.6**) does not suggest any atypical safety issues in the existing road network. The additional traffic movements generated by the emergency bulkhead is not considered to increase the likelihood of crashes to unacceptable levels.

### 4.4. Safe Intersection Sight Distance – Site Exit

The Safe Intersection Sight Distance (SISD) is the minimum distance which should be provided on the major road at any intersection. SISD provides sufficient distance for a driver of a vehicle on the major road to observe a vehicle on a minor road approach moving into a collision situation (e.g. in the worst case, stalling across the traffic lanes) and to decelerate to a stop before reaching the collision point.

The SISD for the site exit along Leeming Road is assessed based on the following parameters:

- An observation time of 3 seconds as per Austroads Part 3;
- A reaction time of 2.5 seconds;
- Deceleration coefficients for the purpose of SISD calculations are 0.36 for light vehicles and 0.28 for heavy vehicles (Road Train Type 2 – RAV 7 equivalent);
- Driver eye height is 2.4m for trucks and 1.1m for cars; and



- Design speed for cars at 60km/h and trucks at 50km/h.

**Figure 10** and **Figure 11** show the available sight distance along Leeming Road from the site access. Note that although Leeming Road continues as an unsealed track extending west from the end of the cul-de-sac, there is a sight board and gate that prevent access. For illustrative purposes, the sight distance measurements extend past the sight board and gate along the track.

The available sight distances are measured at approximately 520m and 510m to the west and east, respectively, as shown in **Figure 12**.



Figure 10: Looking East Along Leeming Road from Site Access



Figure 11: Looking West Along Leeming Road from Site Access



Figure 12: Site Access SISD



Based on the sight distance parameters, **Table 6** shows a comparison between the required and available sight distances from the site access. As shown, the available sight distances are significantly greater than the minimum requirements.

**Table 6: SISD at Site Access**

| Location  | Vehicle Type | Design Speed (km/h) (EB / WB) | Coefficient of Deceleration | Decision Time (s) | Longitudinal Grade (EB / WB) <sup>a</sup> | Required SISD for EB / WB Traffic (m) | Available SISD (m) |     |
|-----------|--------------|-------------------------------|-----------------------------|-------------------|---|---------------------------------------|--------------------|-----|
|           |              |                               |                             |                   |   |                                       | EB                 | WB  |
| Site Exit | Trucks       | 50 / 50                       | 0.28                        | 3+2.5             | 2%/3%                                     | 109 / 108                             | 520                | 510 |
|           | Cars         | 60 / 60                       | 0.36                        | 3+2.5             | 2%/3%                                     | 129 / 128                             | 520                | 510 |

<sup>a</sup>Positive for through traffic travelling uphill and negative for through traffic travelling downhill. Grades are estimated only.

#### 4.5. Entering Sight Distance – Site Exit

The Entering Sight Distance (ESD) is the minimum distance for driver of a RAV, entering a through road, having appropriate sight distance to see a sufficient gap in oncoming traffic that will allow a RAV, with greater length and lower acceleration capacity, to clear the intersection safely.

The ESD is assessed based on the following parameters:

- A reaction time of 4 seconds, and
- Deceleration coefficients of 0.29 (up to 90km/hr).

The Entering Sight Distance (ESD) for existing and proposed access locations has been assessed in accordance with RAV Route Assessment Guideline (updated May 2022). A comparison of available and required ESD for RAV vehicles are summarised in **Table 7**.

**Table 7: RAV Vehicle Entering Sight Distance**

| Location  | Design Speed (km/h) (EB / WB) | Coefficient of Deceleration | Reaction Time (s) | Longitudinal Grade (EB / WB) <sup>a</sup> | Required ESD for EB / South WB (m) | Available ESD (m) |     |
|-----------|-------------------------------|-----------------------------|-------------------|---|------------------------------------|-------------------|-----|
|           |                               |                             |                   |   |                                    | EB                | WB  |
| Site Exit | 50 / 50                       | 0.29                        | 4                 | 2% / 3%                                   | 242 / 238                          | 520               | 510 |

<sup>a</sup>Positive for through traffic travelling uphill and negative for through traffic travelling downhill. Grades are estimated only.

As shown, the ESD are sufficient to achieve minimum requirements in accordance with the MRWA RAV Assessment Guideline.



---

## 5. Conclusions

This Traffic Impact Statement has been prepared for the proposed Emergency TBH to be installed at CBH's existing Meenaar site. The TIS concluded:

- The estimated traffic generation can be accommodated within the capacity of the adjacent road network.
- The additional traffic generated by the site is not considered to increase the likelihood of crashes to unacceptable levels.
- The seal and carriageway widths of the surrounding road network generally meet the relevant RAV network requirements.
- There is sufficient sight distance at the existing site exit.





---

**Appendix A – CBH Concept Plan**

---



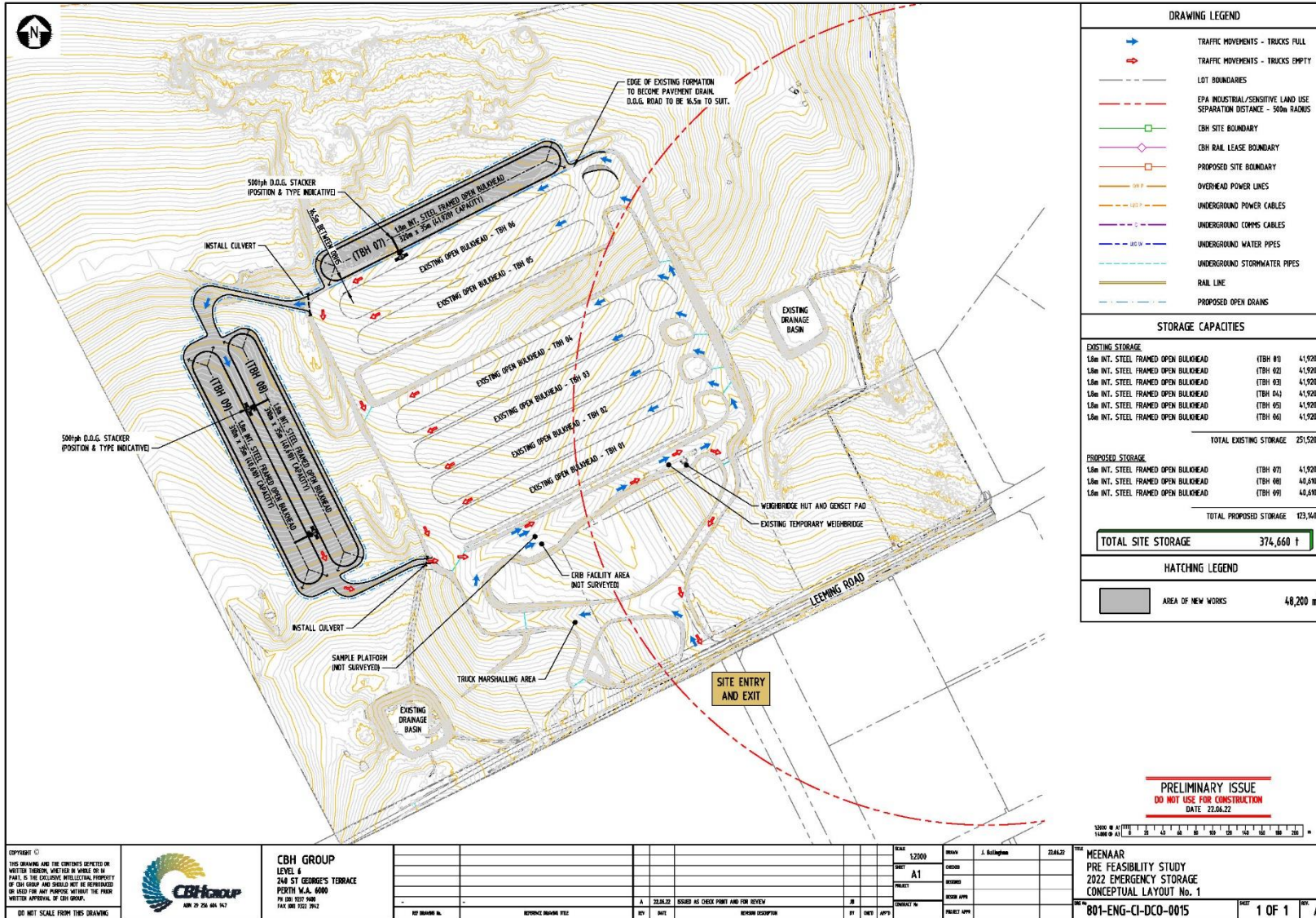



---

**Appendix B – Traffic Count Data**

---



SITE 53258

## Hourly Volume

Leeming Rd (4211128)

2020/21  
 Monday to Friday

South of Great Eastern Hwy (SLK 4.40)

|              | All Vehicles |           |            |             | Heavy Vehicles |           |           |             |  |  |
|--------------|--------------|-----------|------------|-------------|----------------|-----------|-----------|-------------|--|--|
|              | NB           | SB        | Both       | %           | NB             | SB        | Both      | %           |  |  |
| 00:00        | 0            | 0         | 0          | 0.0         | 0              | 0         | 0         | 0.0         |  |  |
| 01:00        | 0            | 0         | 0          | 0.0         | 0              | 0         | 0         | 0.0         |  |  |
| 02:00        | 0            | 0         | 0          | 0.0         | 0              | 0         | 0         | 0.0         |  |  |
| 03:00        | 0            | 0         | 0          | 0.0         | 0              | 0         | 0         | 0.0         |  |  |
| 04:00        | 0            | 1         | 1          | 0.0         | 0              | 0         | 0         | 0.0         |  |  |
| 05:00        | 0            | 12        | 12         | 0.0         | 0              | 0         | 0         | 0.0         |  |  |
| 06:00        | 3            | 12        | 15         | 20.0        | 2              | 1         | 3         | 20.0        |  |  |
| 07:00        | 6            | 8         | 14         | 28.6        | 3              | 1         | 4         | 28.6        |  |  |
| 08:00        | 5            | 8         | 13         | 46.2        | 3              | 3         | 6         | 46.2        |  |  |
| 09:00        | 2            | 4         | 6          | 16.7        | 0              | 1         | 1         | 16.7        |  |  |
| 10:00        | 3            | 5         | 8          | 25.0        | 1              | 1         | 2         | 25.0        |  |  |
| 11:00        | 3            | 4         | 7          | 14.3        | 0              | 1         | 1         | 14.3        |  |  |
| 12:00        | 5            | 4         | 9          | 22.2        | 1              | 1         | 2         | 22.2        |  |  |
| 13:00        | 5            | 4         | 9          | 44.4        | 2              | 2         | 4         | 44.4        |  |  |
| 14:00        | 4            | 3         | 7          | 42.9        | 1              | 2         | 3         | 42.9        |  |  |
| 15:00        | 11           | 3         | 14         | 7.1         | 1              | 0         | 1         | 7.1         |  |  |
| 16:00        | 15           | 1         | 16         | 12.5        | 2              | 0         | 2         | 12.5        |  |  |
| 17:00        | 9            | 1         | 10         | 20.0        | 2              | 0         | 2         | 20.0        |  |  |
| 18:00        | 1            | 1         | 2          | 0.0         | 0              | 0         | 0         | 0.0         |  |  |
| 19:00        | 1            | 2         | 3          | 33.3        | 0              | 1         | 1         | 33.3        |  |  |
| 20:00        | 1            | 0         | 1          | 0.0         | 0              | 0         | 0         | 0.0         |  |  |
| 21:00        | 0            | 0         | 0          | 0.0         | 0              | 0         | 0         | 0.0         |  |  |
| 22:00        | 0            | 0         | 0          | 0.0         | 0              | 0         | 0         | 0.0         |  |  |
| 23:00        | 0            | 0         | 0          | 0.0         | 0              | 0         | 0         | 0.0         |  |  |
| <b>TOTAL</b> | <b>74</b>    | <b>73</b> | <b>147</b> | <b>21.8</b> | <b>18</b>      | <b>14</b> | <b>32</b> | <b>21.8</b> |  |  |



### Peak Statistics

| AM  | TIME | 07:30 | 05:45 | 07:30 | 06:15 | 07:30 | 07:30 |
|-----|------|-------|-------|-------|-------|-------|-------|
| VOL |      | 7     | 15    | 19    | 4     | 3     | 7     |
| PM  | TIME | 15:45 | 13:45 | 15:45 | 16:30 | 13:45 | 13:45 |
| VOL |      | 16    | 5     | 18    | 4     | 3     | 5     |

Volume

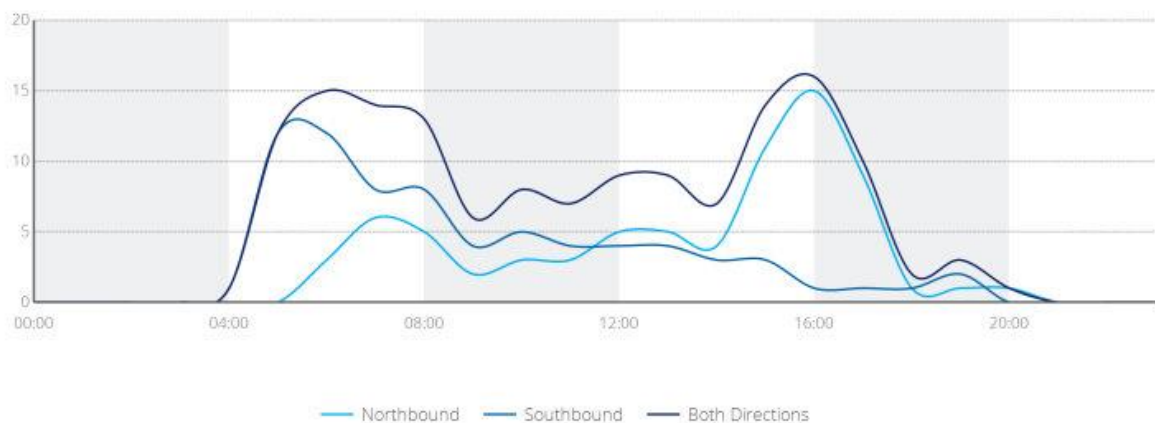



SITE 53258

## Hourly Volume

Leeming Rd (4211128)

2020/21  
 Monday to Sunday

South of Great Eastern Hwy (SLK 4.40)

|              | All Vehicles |           |            | Heavy Vehicles |          |           |           |             |
|--------------|--------------|-----------|------------|----------------|----------|-----------|-----------|-------------|
|              | NB           | SB        | Both       | NB             | SB       | Both      | Truck     | %           |
| 00:00        | 0            | 0         | 0          | 0              | 0        | 0         | 0         | 0.0         |
| 01:00        | 0            | 0         | 0          | 0              | 0        | 0         | 0         | 0.0         |
| 02:00        | 0            | 0         | 0          | 0              | 0        | 0         | 0         | 0.0         |
| 03:00        | 0            | 0         | 0          | 0              | 0        | 0         | 0         | 0.0         |
| 04:00        | 0            | 1         | 1          | 0              | 0        | 0         | 0         | 0.0         |
| 05:00        | 0            | 9         | 9          | 0              | 0        | 0         | 0         | 0.0         |
| 06:00        | 3            | 9         | 12         | 2              | 1        | 3         | 3         | 25.0        |
| 07:00        | 6            | 6         | 12         | 4              | 1        | 5         | 5         | 41.7        |
| 08:00        | 3            | 6         | 9          | 1              | 3        | 4         | 4         | 44.4        |
| 09:00        | 2            | 2         | 4          | 0              | 0        | 0         | 0         | 0.0         |
| 10:00        | 2            | 3         | 5          | 0              | 0        | 0         | 0         | 0.0         |
| 11:00        | 2            | 4         | 6          | 0              | 1        | 1         | 1         | 16.7        |
| 12:00        | 4            | 4         | 8          | 1              | 1        | 2         | 2         | 25.0        |
| 13:00        | 4            | 3         | 7          | 2              | 2        | 4         | 4         | 57.1        |
| 14:00        | 4            | 1         | 5          | 1              | 0        | 1         | 1         | 20.0        |
| 15:00        | 8            | 2         | 10         | 1              | 0        | 1         | 1         | 10.0        |
| 16:00        | 10           | 1         | 11         | 1              | 0        | 1         | 1         | 9.1         |
| 17:00        | 6            | 1         | 7          | 1              | 0        | 1         | 1         | 14.3        |
| 18:00        | 1            | 1         | 2          | 0              | 0        | 0         | 0         | 0.0         |
| 19:00        | 0            | 0         | 0          | 0              | 0        | 0         | 0         | 0.0         |
| 20:00        | 0            | 0         | 0          | 0              | 0        | 0         | 0         | 0.0         |
| 21:00        | 0            | 0         | 0          | 0              | 0        | 0         | 0         | 0.0         |
| 22:00        | 0            | 0         | 0          | 0              | 0        | 0         | 0         | 0.0         |
| 23:00        | 0            | 0         | 0          | 0              | 0        | 0         | 0         | 0.0         |
| <b>TOTAL</b> | <b>55</b>    | <b>53</b> | <b>108</b> | <b>14</b>      | <b>9</b> | <b>23</b> | <b>23</b> | <b>21.3</b> |



### Peak Statistics

|    |      |       |       |              |       |       |              |
|----|------|-------|-------|--------------|-------|-------|--------------|
| AM | TIME | 07:00 | 05:30 | <b>05:45</b> | 06:30 | 07:30 | <b>07:15</b> |
|    | VOL  | 6     | 11    | <b>14</b>    | 4     | 3     | <b>6</b>     |
| PM | TIME | 15:45 | 13:30 | <b>15:30</b> | 13:15 | 13:30 | <b>13:15</b> |
|    | VOL  | 11    | 4     | <b>14</b>    | 3     | 2     | <b>5</b>     |

Volume

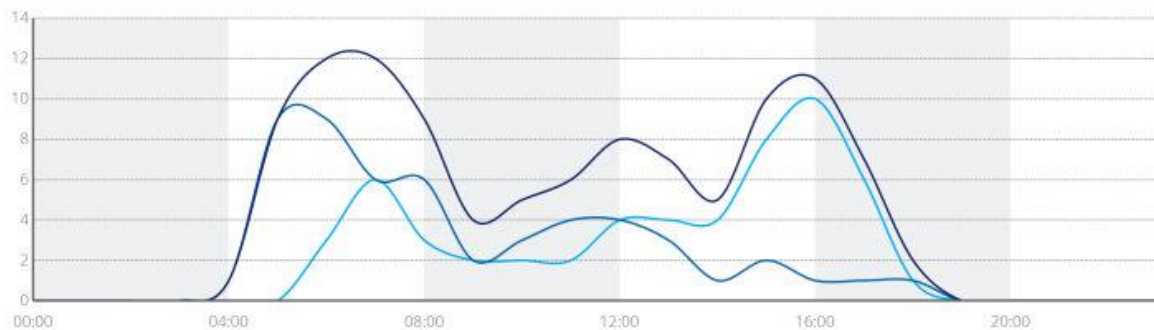

— Northbound — Southbound — Both Directions



SITE 53258

## Hourly Volume

Leeming Rd (4211128)

2020/21  
Weekend

South of Great Eastern Hwy (SLK 4.40)

|              | All Vehicles |           |           |  | Heavy Vehicles |          |          |  |             |  |
|--------------|--------------|-----------|-----------|--|----------------|----------|----------|--|-------------|--|
|              | NB           | SB        | Both      |  | NB             | SB       | Both     |  | %           |  |
| 00:00        | 0            | 0         | 0         |  | 0              | 0        | 0        |  | 0.0         |  |
| 01:00        | 0            | 0         | 0         |  | 0              | 0        | 0        |  | 0.0         |  |
| 02:00        | 0            | 0         | 0         |  | 0              | 0        | 0        |  | 0.0         |  |
| 03:00        | 0            | 0         | 0         |  | 0              | 0        | 0        |  | 0.0         |  |
| 04:00        | 0            | 0         | 0         |  | 0              | 0        | 0        |  | 0.0         |  |
| 05:00        | 0            | 3         | 3         |  | 0              | 0        | 0        |  | 0.0         |  |
| 06:00        | 1            | 2         | 3         |  | 1              | 0        | 1        |  | 33.3        |  |
| 07:00        | 2            | 1         | 3         |  | 1              | 0        | 1        |  | 33.3        |  |
| 08:00        | 2            | 1         | 3         |  | 0              | 0        | 0        |  | 0.0         |  |
| 09:00        | 1            | 0         | 1         |  | 0              | 0        | 0        |  | 0.0         |  |
| 10:00        | 1            | 1         | 2         |  | 0              | 0        | 0        |  | 0.0         |  |
| 11:00        | 0            | 1         | 1         |  | 0              | 0        | 0        |  | 0.0         |  |
| 12:00        | 2            | 1         | 3         |  | 0              | 0        | 0        |  | 0.0         |  |
| 13:00        | 3            | 2         | 5         |  | 1              | 1        | 2        |  | 40.0        |  |
| 14:00        | 3            | 0         | 3         |  | 0              | 0        | 0        |  | 0.0         |  |
| 15:00        | 2            | 1         | 3         |  | 1              | 0        | 1        |  | 33.3        |  |
| 16:00        | 1            | 0         | 1         |  | 0              | 0        | 0        |  | 0.0         |  |
| 17:00        | 0            | 0         | 0         |  | 0              | 0        | 0        |  | 0.0         |  |
| 18:00        | 1            | 2         | 3         |  | 0              | 0        | 0        |  | 0.0         |  |
| 19:00        | 0            | 0         | 0         |  | 0              | 0        | 0        |  | 0.0         |  |
| 20:00        | 0            | 0         | 0         |  | 0              | 0        | 0        |  | 0.0         |  |
| 21:00        | 0            | 1         | 1         |  | 0              | 0        | 0        |  | 0.0         |  |
| 22:00        | 0            | 0         | 0         |  | 0              | 0        | 0        |  | 0.0         |  |
| 23:00        | 0            | 0         | 0         |  | 0              | 0        | 0        |  | 0.0         |  |
| <b>TOTAL</b> | <b>19</b>    | <b>16</b> | <b>35</b> |  | <b>4</b>       | <b>1</b> | <b>5</b> |  | <b>14.3</b> |  |



### Peak Statistics

|           |             |       |       |       |       |       |       |
|-----------|-------------|-------|-------|-------|-------|-------|-------|
| <b>AM</b> | <b>TIME</b> | 07:15 | 05:00 | 07:30 | 06:30 | 00:00 | 06:30 |
|           | <b>VOL</b>  | 3     | 3     | 5     | 2     | 0     | 2     |
| <b>PM</b> | <b>TIME</b> | 13:30 | 12:45 | 13:30 | 15:00 | 13:30 | 13:00 |
|           | <b>VOL</b>  | 4     | 3     | 6     | 1     | 1     | 2     |

Volume

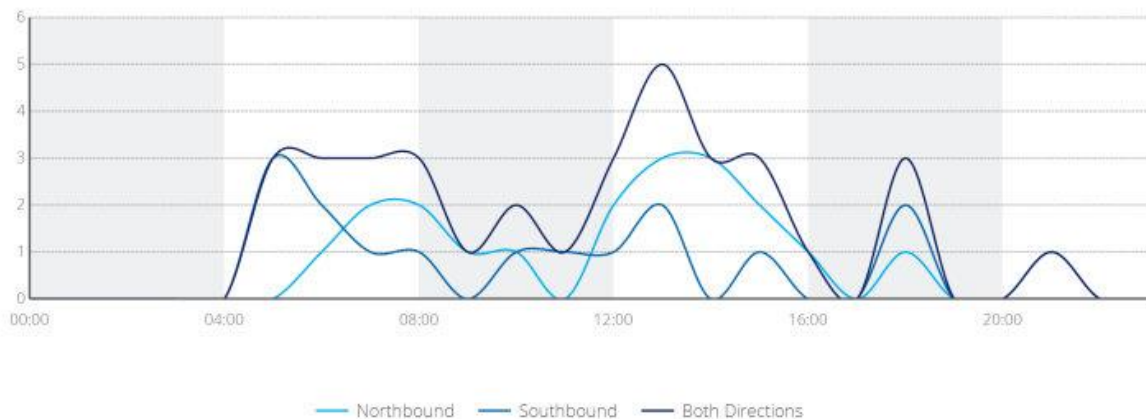

Cr M I Girak declared a "Proximity" interest in item 13.3.2 – Proposed Review of the Heritage List as Cr Girak's residential property is on the proposed Heritage List.

Cr A J Mencshelyi declared a "Impartiality" interest in item 13.3.2 – Proposed Review of the Heritage List as some property owners on the proposed Heritage List are known to Cr Mencshelyi.

Cr R W Tinetti declared a "Impartiality" interest in item 13.3.2 – Proposed Review of the Heritage List as some property owners on the proposed Heritage List are known to Cr Tinetti.

Cr M P Ryan declared a "Impartiality" interest in item 13.3.2 – Proposed Review of the Heritage List as one of the property owners on the proposed Heritage List are known to Cr Ryan.

Cr D A Hughes declared a "Impartiality" interest in item 13.3.2 – Proposed Review of the Heritage List as one of the property owners on the proposed Heritage List are known to Cr Hughes.

Cr J E G Williams declared a "Impartiality" interest in item 13.3.2 – Proposed Review of the Heritage List as some property owners on the proposed Heritage List are known to Cr Williams.

Cr C R Antonio declared a "Impartiality" interest in item 13.3.2 – Proposed Review of the Heritage List as some property owners on the proposed Heritage List are known to Cr Antonio.

### 13.3.2 Proposed Review of the Heritage List

|   |  |
|---|--|
| <b>Address:</b>                         | Various  |
| <b>Owner:</b>                           | Various  |
| <b>Applicant:</b>                       | Shire of Northam                                   |
| <b>File Reference:</b>                  | 3.1.8.19   |
| <b>Reporting Officer:</b>               | Jacky Jurmann, Manager Planning & Environment      |
| <b>Responsible Officer:</b>             | Chadd Hunt, Executive Manager Development Services |
| <b>Officer Declaration of Interest:</b> | Nil  |
| <b>Voting Requirement:</b>              | Simple   |
| <b>Press release to be issued:</b>      | No   |

#### BRIEF

Council at its Ordinary Meeting held on 18 May 2022 resolved to adopt the draft amended Heritage List for advertising purposes.



The advertising has been completed and four submissions were received. The issues raised in the submissions have been considered and the draft amended Heritage List is now presented to Council for adoption.

## ATTACHMENTS

- Attachment 1: Draft Amended Heritage List.  
Attachment 2: Updated Place Records.  
Attachment 3: Schedule of Submissions.

---

## A. BACKGROUND / DETAILS

As indicated in the previous Report on this matter, it is proposed to include an additional 27 places on the Shire's Heritage List to recognise their importance and provide an adequate level of protection.

These places were identified as part of a minor review of the Heritage List and new or amended place record forms have been created for each property providing justification for their inclusion, including information on their background and significance.

## B. CONSIDERATIONS

### B.1 Strategic Community / Corporate Business Plan

Theme Area: Environment & Heritage

Outcome: The Shire of Northam honours, and is recognised for, its unique heritage and cultural identity.

Objective: The Shire of Northam is a destination for heritage tourism and heritage buildings are easily located and interpreted; The Shire of Northam's heritage buildings and locations are well maintained.

### B.2 Financial / Resource Implications

The review of the Heritage List is within current budget.

### B.3 Legislative Compliance

*Planning and Development (Local Planning Schemes) Regulations 2015*  
Clause 8(1)(3) of Part 3 of Schedule 2 of the Regulations (also known as the Deemed Provisions) sets out the consultation requirements for entering or removing a place from the heritage list, or modifying the heritage list, and includes notifying each owner and occupier of the place to provide a minimum of 21 days to comment. Following adoption of the list (and any subsequent modifications), the Shire must notify the Heritage Council of WA, and each owner and occupier.

#### B.4 Policy Implications

The inclusion of the subject places on the Heritage List will provide an appropriate level of statutory protection.

#### B.5 Stakeholder Engagement / Consultation

Consultation was conducted in accordance with the provisions of the Regulations (as outlined above) for a minimum period of 21 days to all landowners and occupiers. The draft amended Heritage List was also advertised to the community on the Shire's website and social media.

Four (4) submissions were received in response and the issues raised in the submissions were considered in the finalisation of the proposed amendments. Refer to the Schedule of Submissions for details.

#### B.6 Risk Implications

| Risk Category        | Description                              | Rating<br>(likelihood x consequence)       | Mitigation Action                                    |
|----------------------|--|--|--|
| Financial            | Nil                                      | Nil  | Nil  |
| Health & Safety      | Nil                                      | Nil  | Nil  |
| Reputation           | Nil                                      | Nil  | Nil  |
| Service Interruption | Nil                                      | Nil  | Nil  |
| Compliance           | Comply with requirements of Regulations. | Insignificant (1) x Unlikely (2) = Low (2) | Ensure compliance, particularly during consultation. |
| Property             | Nil                                      | Nil  | Nil  |
| Environment          | Nil                                      | Nil  | Nil  |

#### B.7 Natural Environment Considerations

Nil.

### C. OFFICER'S COMMENT

As outlined in the Schedule of Submissions, the contents of the submissions were considered by the Shire's Heritage Consultant and where appropriate modifications have been made to the Place Records, and if necessary, the draft amended Heritage List.

Following adoption of the amended list, the State Heritage Office's database Inherit will be updated to reflect the changes and the affected landowners will be advised.

The next stage in the Shire's review of its management of local heritage places is the creation of a strategic framework. This work has been funded by a grant from the Heritage Council, and in conjunction with the Shire's Heritage Consultant, a staged review of the Local Heritage Survey (formerly

known as the Municipal Heritage Inventory) will be conducted. This review will inform any subsequent amendments to the Heritage List.

Extensive community consultation will be conducted as part of this project to ensure that all places of heritage significance are recognised and afforded the appropriate level of protection.

**RECOMMENDATION**

**That Council:**

- 1. Adopt the draft amended Heritage List; and**
- 2. Notify all affected land owners and occupiers and the State Heritage Council of the amendments to the Heritage List.**

**Attachment 1: Draft Amended Heritage List**

**SHIRE OF NORTHAM  
LOCAL PLANNING SCHEME NO. 6  
REGISTER 1 – HERITAGE LIST**

## 1. INTRODUCTION

The provisions for the adoption of a Heritage List under the provisions of the Northam Local Planning Scheme No. 5 are outlined in Schedule 2 of the *Planning and Development (Local Planning Schemes) Regulations 2015* known as the Deemed Provisions.

*Note: Deemed provisions are those provisions that are automatically incorporated into a local planning scheme.*

## 2. SCHEME PROVISIONS UNDER SHIRE OF NORTHAM LOCAL PLANNING SCHEME NO. 6

The provisions state:

### 8. Heritage list

- (1) The local government must establish and maintain a heritage list to identify places within the Scheme area that are of cultural heritage significance and worthy of built heritage conservation.
- (2) The heritage list —
  - (a) must set out a description of each place and the reason for its entry in the heritage list; and
  - (b) must be available, with the Scheme documents, for public inspection during business hours at the offices of the local government; and
  - (c) may be published on the website of the local government.
- (3) The local government must not enter a place in, or remove a place from, the heritage list or modify the entry of a place in the heritage list unless the local government —
  - (a) notifies in writing each owner and occupier of the place and provides each of them with a description of the place and the reasons for the proposed entry; and
  - (b) invites each owner and occupier to make submissions on the proposal within 21 days of the day on which the notice is served or within a longer period specified in the notice; and
  - (c) carries out any other consultation the local government considers appropriate; and
  - (d) following any consultation and consideration of the submissions made on the proposal, resolves that the place be entered in the heritage list with or without modification, or that the place be removed from the heritage list.
- (4) If the local government enters a place in the heritage list or modifies an entry of a place in the heritage list the local government must give notice of the entry or modification to —
  - (a) the Heritage Council of Western Australia; and
  - (b) each owner and occupier of the place.

---

Shire of Northam – Heritage List

### 3. HERITAGE LIST REGISTER

The following is the Heritage List Register.

| Heritage List # | Common Name                              | Lot No.      | House No. | Street            | Suburb    | Assess. No | Management Category | MHI Ref. | Inherit Ref. | Reason for Entry  |
|-----------------|--|--------------|-----------|-------------------|-----------|------------|---------------------|----------|--------------|---|
| 1.              | Northam Fire Station (fmr #2) & Quarters | 158          | 87        | Duke Street       | Northam   | A10590     | 1                   | 13       | 1852         | As per <a href="#">SRHP Statement of Significance</a> . |
| 2.              | Uniting Church & Hall                    | 611          | 103       | Duke Street East  | Northam   | A14327     | 1                   | 34       | 16300        | As per <a href="#">SRHP Statement of Significance</a> . |
| 3.              | Colonial Tavern & Stables                | 8-10         | 197       | Duke Street East  | Northam   | A14398     | 1                   | 8        | 1855         | As per <a href="#">SRHP Statement of Significance</a> . |
| 4.              | Bardeen Homestead Group                  | 100, 104-105 | 866       | Dumbarton Road    | Irishtown | A425       | 1                   | 3        | 3414         | As per <a href="#">SRHP Statement of Significance</a> . |
| 5.              | Union Bank (ANZ Bank)                    | 15-16        | 133       | Fitzgerald Street | Northam   | A11041     | 1                   | 1        | 1861         | As per <a href="#">SRHP Statement of Significance</a> . |
| 6.              | National Australia Bank                  | 7            | 141       | Fitzgerald Street | Northam   | A11049     | 1                   | 62       | 14788        | As per <a href="#">SRHP Statement of Significance</a> . |
| 7.              | Bank of New South Wales (fmr)            | 113          | 161       | Fitzgerald Street | Northam   | A11060     | 1                   | 36       | 1872         | As per <a href="#">SRHP Statement of Significance</a> . |
| 8.              | Commonwealth Bank                        | 111-112      | 181       | Fitzgerald Street | Northam   | A11079     | 1                   | 9        | 1871         | As per <a href="#">SRHP Statement of Significance</a> . |
| 9.              | Co-op (fmr) (Community Health Building)  | 14           | 222       | Fitzgerald Street | Northam   | A11115     | 1                   | 10       | 10880        | As per MHI Place Record.                                |

| Heritage List # | Common Name                                      | Lot No.                   | House No. | Street                                | Suburb  | Assess. No | Management Category | MHI Ref. | Inherit Ref. | Reason for Entry  |
|-----------------|--|---------------------------|-----------|---------------------------------------|---------|------------|---------------------|----------|--------------|---|
| 10.             | Northam Post Office & Quarters                   | 1                         | 239-243   | Fitzgerald Street                     | Northam | A13258     | 1                   | 24       | 1867         | As per <a href="#">SRHP Statement of Significance</a> . |
| 11.             | Town Council Offices (fmr) & Library             | 17 & 18                   | 298       | Fitzgerald Street East (cnr Glebe St) | Northam | A11140     | 1                   | 26       | 10907        | As per <a href="#">SRHP Statement of Significance</a> . |
| 12.             | Northam Railway Station                          | 359 & 370 (Reserve 31355) | 401       | Fitzgerald Street West                | Northam | A11190     | 1                   | 25       | 1859         | As per <a href="#">SRHP Statement of Significance</a> . |
| 13.             | John Morrell's Grave                             | 26637                     | -         | Goomalling Road (cnr Gillett Rd)      | Northam | A11264     | 1                   | 17       | 1885         | As per <a href="#">SRHP Statement of Significance</a> . |
| 14.             | Byfield House                                    | 1-3                       | 30        | Gordon Street                         | Northam | A14058     | 1                   | 5        | 1878         | As per <a href="#">SRHP Statement of Significance</a> . |
| 15.             | Uralia (Rosalyn, St John of God Hospital)        | 347                       | 59        | Gordon Street                         | Northam | A14343     | 1                   | 35       | 1876         | As per <a href="#">SRHP Statement of Significance</a> . |
| 16.             | Northam Army Camp                                | 28465                     |           | Great Eastern Highway                 | Burlong | A496       | 1                   | 68       | 6126         | As per <a href="#">SRHP Statement of Significance</a> . |
| 17.             | The Residency (The Magistrate's Residence (fmr)) | 330                       | 42        | Habgood Street                        | Northam | A11407     | 1                   | 31       | 1880         | As per <a href="#">SRHP Statement of Significance</a> . |
| 18.             | Mitchell House (Bona Vista)                      | 33                        | 15-17     | Hawes Street (cnr Duke St)            | Northam | A13332     | 1                   | 18       | 1882         | As per <a href="#">SRHP Statement of Significance</a> . |

| Heritage List # | Common Name                                    | Lot No.         | House No. | Street                                  | Suburb       | Assess. No | Management Category | MHI Ref. | Inherit Ref. | Reason for Entry  |
|-----------------|--|-----------------|-----------|---|--------------|------------|---------------------|----------|--------------|---|
| 19.             | Buckland Homestead & Farm Buildings            | 60              | 972       | Irishtown Road                          | Buckland     | A15736     | 1                   | 4        | 1843         | As per <a href="#">SRHP Statement of Significance</a> . |
| 20.             | Morby Farm Cottage                             | 600             | 70        | Katrine Road                            | Katrine      | A13075     | 1                   | 19       | 1837         | As per <a href="#">SRHP Statement of Significance</a> . |
| 21.             | Northam (Pioneer) Cemetery (1856+)             | Avon Loc. 20511 | 160       | Katrine Road                            | Northam      | A14141     | 1                   | 21       | 3976         | As per <a href="#">SRHP Statement of Significance</a> . |
| 22.             | Northam Senior High School                     | 463             | 30        | Kennedy Street                          | Northam      | A14136     | 1                   | 66       | 1883         | As per <a href="#">SRHP Statement of Significance</a> . |
| 23.             | Fermoy House (fmr), St Joseph's Primary School | 236 & 60        | 1         | Lance Street                            | Northam      | A15718     | 1                   | 47       | 1874         | As per <a href="#">SRHP Statement of Significance</a> . |
| 24.             | Railway Goods Shed                             | 438             | 437       | Morrell Street                          | West Northam | A12015     | 1                   | 15       | 17618        | As per <a href="#">Updated Place Record</a> .           |
| 25.             | Enfield House                                  | 1               | 12        | Newcastle Road (Corner Enfield Terrace) | Northam      | A12176     | 1                   | 12       | 10882        | As per <a href="#">Updated Place Record</a> .           |
| 26.             | Curdnatta                                      | 32              | 22        | Newcastle Road                          | Northam      | A12187     | 1                   | 11       | 10881        | As per <a href="#">SRHP Statement of Significance</a> . |
| 27.             | St John's Anglican Church & Parish Hall        | 90              | 11        | Wellington Street                       | Northam      | A12502     | 1                   | 33       | 1891         | As per <a href="#">SRHP Statement of Significance</a> . |
| 28.             | Northam State School (fmr) (Avon               | 380             | 33        | Wellington Street                       | Northam      | A13095     | 1                   | 29       | 1881         | As per <a href="#">SRHP Statement of Significance</a> . |



| Heritage List # | Common Name   | Lot No. | House No. | Street   | Suburb      | Assess. No | Management Category | MHI Ref. | Inherit Ref.       | Reason for Entry  |
|-----------------|---|---------|-----------|--|-------------|------------|---------------------|----------|--------------------|---|
|                 | Valley Arts Workshop)                               |         |           |  |             |            |                     |          |                    |   |
| 29.             | Northam Post Office (fmr) (Avon Valley Arts Centre) | 380     | 33        | Wellington Street  | Northam     | A13095     | 1                   | 29       | 1892<br>1867       | As per <a href="#">SRHP Statement of Significance</a> . |
| 30.             | Northam Town Hall & Lesser Hall                     | 86      | 85        | Wellington Street (cnr Gordon Street)                              | Northam     | A13409     | 1                   | 27       | 1877               | As per <a href="#">SRHP Statement of Significance</a> . |
| 31.             | Northam Police Station & Court House                | 429     | 114       | Wellington Street  | Northam     | A14132     | 1                   | 23       | 1890               | As per <a href="#">SRHP Statement of Significance</a> . |
| 32.             | Northam Police Station (former)                     | 254     | 128       | Wellington Street (cnr Fitzgerald Street)                          | Northam     | A12551     | 1                   | 23       | 17372<br>&<br>1869 | As per MHI Place Record.                                |
| 33.             | Railway Institute                                   | 453     | 182       | Wellington Street  | Northam     | A12641     | 1                   | 30       | 1898               | As per MHI Place Record.                                |
| 34.             | Hoopers Winery & Surrounds (Keanes Vineyards)       | 5739    | 9         | Yates Street   | Bakers Hill | A2052      | 1                   | 16       | 10917              | As per <a href="#">SRHP Statement of Significance</a> . |
| 35.             | Chauncy's Cairn                                     |         |           | North of Cobb Road, Chidlow State Forest                           | Woottatting |            | 1                   | 6        | 8565               | As per <a href="#">SRHP Statement of Significance</a> . |
| 36.             | Clackline Bridge or Viaduct                         |         |           | Over Clackline Brook and Railway (500m east of Clackline townsite) | Clackline   |            | 1                   | 7        | 10910              | As per <a href="#">SRHP Statement of Significance</a> . |

| Heritage List # | Common Name                     | Lot No.              | House No. | Street                  | Suburb      | Assess. No | Management Category | MHI Ref. | Inherit Ref. | Reason for Entry  |
|-----------------|---------------------------------|----------------------|-----------|-------------------------|-------------|------------|---------------------|----------|--------------|---|
| 37.             | Goldfields Water Supply         |                      |           | Mundaring to Kalgoorlie | Northam LGA |            | 1                   | 14       | 25251        | As per <a href="#">SRHP Statement of Significance</a> .         |
| 38.             | Methodist Manse (fmr)           | 62                   | 100       | Chidlow Street          | Northam     | A14199     | 2                   | 59       | 24992        | As per <a href="#">Updated MHI Place Record</a> .               |
| 39.             | Jacaranda House                 | 7-8                  | 25        | Duke Street             | Northam     | A10556     | 2                   | NEW      | NEW          | As per <a href="#">Place Record</a> .                           |
| 40.             | Northam Flour Mill              | 100 & 34             | 334       | Fitzgerald Street East  | Northam     | A15569     | 2                   | 64       | 10889        | As MHI Place Record & <a href="#">SRHP Interim Assessment</a> . |
| 41.             | Grand Hotel (fmr)               | 146-147              | 426       | Fitzgerald Street       | Northam     | A11194     | 2                   | 51       | 1873         | As per MHI Place Record.  |
| 42.             | Quellington Hall                | 28631 (Reserve 3410) |           | Grass Valley South Road | Quellington | A995       | 2                   | 72       |              | As per MHI Place Record.  |
| 43.             | Stackallan Homestead            | 9501                 | 29        | Henty Place             | Northam     | A15800     | 2                   | NEW      | NEW          | As per <a href="#">Place Record</a> .                           |
| 44.             | Katrine Precinct                | 50                   | 1418      | Katrine Road            | Katrine     | A1722      | 2                   | 54       | 16758        | As per MHI Place Record.  |
| 45.             | Lockyers Mill, Hampton Vineyard | 1                    | 633       | Katrine Road            | Irishtown   | A384       | 2                   | 57       | 3413         | As per MHI Place Record.  |
| 46.             | Carami House                    | 26                   | 38        | Newcastle Road          | Northam     | A12198     | 2                   | 41       | 10879        | As per <a href="#">Updated MHI Place Record</a> .               |
| 47.             | Bakers Hill Railway Platform    | 254                  |           | Newman Street           | Bakers Hill | A16442     | 2                   | NEW      | NEW          | As per <a href="#">Place Record</a> .                           |
| 48.             | St Peters Anglican Church       | 50                   | 1277      | Northam-Pithara Road    | Jennapullin | A1643      | 2                   | 78       | 1847         | As per MHI Place Record.  |

| Heritage List # | Common Name   | Lot No. | House No. | Street                             | Suburb         | Assess. No | Management Category | MHI Ref. | Inherit Ref. | Reason for Entry                      |
|-----------------|---|---------|-----------|------------------------------------|----------------|------------|---------------------|----------|--------------|---------------------------------------|
| 49.             | Egoline Homestead   | 100     | 439       | Northam-Toodyay Road               | Malabaine      | A2050      | 2                   | 46       | 3416         | As per MHI Place Record.              |
| 50.             | Glen Avon & Glen Avon Barn  | 204     | 1252      | Northam-Toodyay Road               | Katrine        | A16114     | 2                   | 32       | 3989         | As per MHI Place Record.              |
| 51.             | Warranine Homestead Group   | 75      | 91        | Old Spencers Brook Road            | Mokine         | A1983      | 2                   | 81       | 1886         | As per MHI Place Record.              |
| 52.             | Mokine Homestead  | 49      | 1662      | Spencers Brook Road                | Mokine         | A15382     | 2                   | 60       | 10919        | As per MHI Place Record.              |
| 53.             | Spencers Brook Tavern (fmr Brookton Hotel)                                      | 148     | 47        | Thomas Street                      | Spencers Brook | A2725      | 2                   | 74       | 1838         | As per MHI Place Record.              |
| 54.             | Barndon House   | 851     | 14        | Wellington Street                  | Northam        | A12499     | 2                   | NEW      | NEW          | As per <a href="#">Place Record</a> . |
| 55.             | Bushmans' House (fmr) (Northam Guest House/ Clearview House/ Temperance Hostel) | 7       | 51        | Wellington Street                  | Northam        | A12507     | 2                   | 41       | 1889         | As per MHI Place Record.              |
| 56.             | St Joseph's Catholic Church Group (Convent & School)                            | 54      | 77        | Wellington Street                  | Northam        | A15185     | 2                   | 76       | 1897         | As per MHI Place Record.              |
| 57.             | St James Anglican Church  | 97      | 185       | Wellington Street (cnr Morrell St) | West Northam   | A13532     | 2                   | 75       | 1899         | As per MHI Place Record.              |
| 58.             | Dr Burrow's Wife's Grave  |         |           | Mt Ommaney                         | Northam        |            | 2                   | 45       |              | As per MHI Place Record.              |

| Heritage List # | Common Name                              | Lot No.         | House No. | Street                            | Suburb       | Assess. No | Management Category | MHI Ref. | Inherit Ref. | Reason for Entry                              |
|-----------------|--|-----------------|-----------|-----------------------------------|--------------|------------|---------------------|----------|--------------|---|
| 59.             | St Simon & St Jude Anglican Church       | 157             | 34        | Boronia Avenue (cnr Banksia Ave)  | Wundowie     | A1571      | 3                   | 111      | 11646        | As per MHI Place Record.                      |
| 60.             | Grass Valley Hotel (fmr Tavern)          | 4 & 132         | 8         | Carter Street (cnr George Street) | Grass Valley | A1961      | 3                   | 97       | 1846         | As per MHI Place Record.                      |
| 61.             | Wundowie Foundry – Factory Office        | 28416           | 52        | Hawke Avenue                      | Wundowie     | A16025     | 3                   | 113      | 10922        | As per MHI Place Record.                      |
| 62.             | Pensioner Guard Cottage (fmr)            | 123             | 1         | McMillan Place                    | Northam      | A13174     | 3                   | 106      | 2661         | As per MHI Place Record.                      |
| 63.             | Exhibition Building & Commemorative Arch | 217             | 44        | Peel Terrace                      | Northam      | A14137     | 3                   | 91       | 18797        | As per MHI Place Record.                      |
| 64.             | Northam Care & Share                     | 401             | 88        | Wellington Street                 | Northam      | A12529     | 3                   | 104      | 25048        | As per <a href="#">Updated Place Record</a> . |
| 65.             | Our Lady Queen of Heaven Church          | 205             | 4         | Zamia Terrace (Cnr Orchid Tce)    | Wundowie     | A1585      | 3                   | 105      | 13106        | As per MHI Place Record.                      |
| 66.             | Agricultural Hall                        | Avon Loc. 00440 |           | Irishtown Rd                      | Irishtown    | A385       | 2                   | 37       | 1844         | As per <a href="#">Updated Place Record</a> . |
| 67.             | Australasia Bank (fmr)                   | 123             | 85        | Fitzgerald St East                | Northam      | A11019     | 2                   | 38       | 1858         | As per <a href="#">Updated Place Record</a> . |
| 68.             | Cody House                               | 120             | 77        | Gordon St                         | Northam      | A16213     | 2                   | 42       | 1879         | As per <a href="#">Updated Place Record</a> . |
| 69.             | Commercial Hotel (Hotel 190)             | 340             | 190       | Fitzgerald St East                | Northam      | A13530     | 2                   | 43       | 1864         | As per <a href="#">Updated Place Record</a> . |

| Heritage List # | Common Name  | Lot No. | House No. | Street             | Suburb  | Assess. No | Management Category | MHI Ref. | Inherit Ref. | Reason for Entry             |
|-----------------|--|---------|-----------|--------------------|---------|------------|---------------------|----------|--------------|------------------------------|
| 70.             | Dempster Homestead, Muresk Institute               | 12      | 1         | Muresk Rd          | Muresk  | A2390      | 2                   | 44       | 10914        | As per Updated Place Record. |
| 71.             | Government Building                                | 223     | 303       | Fitzgerald St East | Northam | A11146     | 2                   | 50       | 1875         | As per Updated Place Record. |
| 72.             | Homeswest (fmr)                                    | 14      | 129       | Fitzgerald St East | Northam | A11071     | 2                   | 52       | 1870         | As per Updated Place Record. |
| 73.             | Lands Office (fmr)                                 | 384     | 263       | Fitzgerald St East | Northam | A11149     | 2                   | 55       | 1866         | As per Updated Place Record. |
| 74.             | Link Theatre                                       | 1-2     | 89        | Duke St East       | Northam | A10591     | 2                   | 56       | 1854         | As per Updated Place Record. |
| 75.             | Masonic Hall (fmr)                                 | 5-6     | 16        | Gordon St          | Northam | A15461     | 2                   | 58       | 10890        | As per Updated Place Record. |
| 76.             | Northam RSL Memorial Hall & Senior Citizens Centre | 131     | 265       | Fitzgerald St East | Northam | A11138     | 2                   | 65       | 13503        | As per Updated Place Record. |
| 77.             | Monument – Chidlow & Jones                         | 5       |           | Dr Dunlop Grove    | Northam | A11237     | 2                   | 61       | 1840         | As per Updated Place Record. |
| 78.             | National Bank (fmr)                                | 750     | 55        | Fitzgerald St East | Northam | A13318     | 2                   | 62       | 1858         | As per Updated Place Record. |
| 79.             | The Northam Advertiser Officer (fmr)               | 600     | 245       | Fitzgerald St East | Northam | A11126     | 2                   | 63       | 1860         | As per Updated Place Record. |

| Heritage List # | Common Name                                | Lot No.        | House No. | Street                                   | Suburb         | Assess. No | Management Category | MHI Ref. | Inherit Ref. | Reason for Entry                       |
|-----------------|--|----------------|-----------|--|----------------|------------|---------------------|----------|--------------|--|
| 80.             | Northam Tavern                             | 151            | 75        | Fitzgerald St East                       | Northam        | A11014     | 2                   | 67       | 1862         | As per Updated Place Record.           |
| 81.             | G J Coles & Co. (fmr)                      | 1              | 178       | Fitzgerald St East                       | Northam        | A11077     | 2                   | 68       | 10886        | As per Updated Place Record.           |
| 82.             | Pine Park                                  | 16             | 61        | Duke St                                  | Northam        | A10577     | 2                   | 69       | 1853         | As per Updated Place Record.           |
| 83.             | Platelayers Cottage (fmr)                  | 29575          |           | Spencers Brook Rd (opp. 38 Rose Terrace) | Spencers Brook | A1474      | 2                   | 70       | 16633        | As per Updated Place Record.           |
| 84.             | Poole St Bridge                            | 505 / R46412   |           | Poole St (spanning over Avon River)      | Northam        | A16360     | 1                   | 28       | 3549         | As per SRHP Statement of Significance. |
| 85.             | Prospect House                             | 2              | 402       | Fitzgerald St West                       | Northam        | A11181     | 2                   | 71       | 10908        | As per Updated Place Record.           |
| 86.             | RAAF Anson Aircraft Monument               | 28827 / R39847 |           | Avro Anson Rd (adjacent No. 35)          | Mokine         | A1647      | 2                   | 73       | 13509        | As per Updated Place Record.           |
| 87.             | Shamrock Hotel (Dome & Farmers Home Hotel) | 800            | 112       | Fitzgerald St West                       | Northam        | A16102     | 1                   | 32       | 1865         | As per SRHP Statement of Significance. |
| 88.             | St Nicholas' Anglican Church               | 159            | 4605      | Great Eastern Hwy                        | Bakers Hill    | A1526      | 2                   | 77       | 1842         | As per Updated Place Record.           |
| 89.             | The Riverside Hotel (Avon Bridge Hotel)    | 450            | 322       | Fitzgerald St East                       | Northam        | A11142     | 1                   | 39       | 1863         | As per Updated Place Record.           |
| 90.             | Throssell Emporium (fmr)                   | 3              | 11        | Peel Terrace                             | Northam        | A12434     | 2                   | 79       | 10891        | As per Updated Place Record.           |

| Heritage List # | Common Name        | Lot No. | House No. | Street           | Suburb  | Assess. No | Management Category | MHI Ref. | Inherit Ref. | Reason for Entry             |
|-----------------|--------------------|---------|-----------|------------------|---------|------------|---------------------|----------|--------------|------------------------------|
| 91.             | Throssell Fountain | 500     | 1         | May Park, May St | Northam | A16321     | 2                   | 92       | 10883        | As per Updated Place Record. |

Register of Entries /Amendments

| H List# | Date of Update | Date of Decision | File reference |
|---------|----------------|------------------|----------------|
| 1       | August 2022    |                  |                |
|         |                |                  |                |
|         |                |                  |                |
|         |                |                  |                |
|         |                |                  |                |







**Attachment 2: Updated Place Records**

| <b>Heritage Item #</b>  |   |   |
|---|---|---|
| MI Reference: 68<br>HCWA No: 10886  | Place Name: G. J. Coles and Co., Limited (fmr)  | Other Name/s: Norrish Realty Building, Northam Travel |
|   |   | Date of Review: September 2021                        |
|    |   |   |
| Address: 178 Fitzgerald Street East, Northam  | Lot No: 19<br>Property Key:<br>Plan Diagram: 697<br>Vol Folio: 1822/59<br>Assess No: A11077 |   |
| Locality: Northam   | GPS:  |   |
| Current Use: Unoccupied (front), WA Country Health Services (rear)  | Original Use(s): Retail   |   |
| <b>HERITAGE LISTINGS</b>  |   |   |
| Listings: Art Deco Significant Building Survey, 1994  |   |   |
| <b>CONSTRUCTION</b>   |   |   |
| Date of Construction: 1937  |   |   |
| Architect / Builder: F. G. B. Hawkins and H. A. Norris  |   |   |
| Architectural Style: Inter-War Functionalist and Art Deco   |   |   |
| <b>PHYSICAL EVIDENCE</b>  |   |   |
| <p>Description:<br/>                     G. J. Coles and Co., Limited (fmr), located at 178 Fitzgerald Street East, is a single storey masonry building with a corrugated steel hip roof displaying characteristics of the Inter-War Functionalist and Art Deco styles of architecture.</p> <p>The building is located on a corner lot adjacent to the Avon Street Mall and town park area. The building has a rendered masonry parapet with detailed vertical pilasters. A curved cantilevered awning addresses the corner and features a stepped parapet with horizontal detailing and signage that reads 'Northam Travel and Cruise'. The underside of the awing is clad with pressed tin detailing.</p> <p>The ground floor is largely glazed with a fixed glass and brass framing. The corner has fixed faceted glazing. The glazing rests on a low plinth that is clad with blue ceramic tile. The entrance is through a set of aluminium framed glazed shop front doors addressing Fitzgerald Street East.</p> |   |   |



|   |
|---|
| The building extends down along Avon Street Mall. The rear of the brick building is painted with a face brick base. The roof is clad with short sheet corrugated steel and features steel roof cowls. The building has been adapted with several large openings extending along the northern façade.  |
| Condition: Good   |
| <b>HISTORICAL</b>   |
| Notes:<br><i>The following information includes extracts from the heritage assessment of 23-325 &amp; 16-334 Fitzgerald Street and 1-15 &amp; 12-18 Peel Terrace, Northam, prepared by Greenward Consulting, June 2015.</i>   |
| The construction of these premises was announced in 1937 in the following extract from <i>The West Australian</i> (10 July 1937):<br><i>Work has begun on the erection of premises to cost £3,130, with an additional £2,400 for shop fronts and counters, for G. J. Coles and Co., Limited, at the corner of Fitzgerald and Avon streets, Northam. The site has a frontage of 43ft. 8in to the main street and a depth of 198ft to Avon-street. Modern display windows of curved glass on the front and for 20 feet down Avon street will be well sheltered from the heat by a 10ft. cantilever verandah with recessed blinds. Black and cream tiles will lead up to entrances of inlaid terrazzo floors and four plate glass doors. The counters are of a good modern design, being finished in walnut plywood and staybrite steel fitted with bag pockets, recesses and other fittings, for ease of working. A complete set of wall fittings has been designed in similar material to that of the counters. About £160 will be spent on the electrical work, with electric fans 20ft. apart. The whole of the building will be fire-proofed with special layers of heat-protecting material over the whole of the roof. The architects are Mr. F. G. B. Hawkins, in association with Mr. H. A. Norris, of Melbourne, and the successful contractor is H. Scholfield. The shop fronts and counters are being executed by Wunderlich, Ltd., and Arcus, Ltd., respectively.</i> |
| As of September 2021, the front building is unoccupied while the rear is occupied by the Government of Western Australia Country Health Services.   |
| Theme: Commercial services and industries; Community services and utilities   |
| Associations: G.J. Coles, F.G.B. Hawkins (Architect)  |
| Heritage Assessment or Conservation Plan: Heritage Assessment of 23-325 & 16-334 Fitzgerald Street and 1-15 & 12-18 Peel Terrace, Northam. Prepared by Greenward Consulting, June 2015.   |
| Public Access: No   |
| <b>SIGNIFICANCE</b>   |
| Level of Integrity: Medium  |
| Level of Authenticity: High   |
| Statement of Significance:  |
| G. J. Coles and Co., Limited (fmr) is of cultural heritage significance for the following reasons: <ul style="list-style-type: none"> <li>The place is significant as a small scale simplistic version of an Inter-War Functionalist building highlighting the Art Deco features that positively contribute to the streetscape of the main commercial street of Northam.</li> </ul>   |
| Level of Significance: Considerable   |
| Heritage Category: 2  |

| Additional Photographs  |   |
|---|---|
|        |     |
| East Corner<br>Source: Municipal Heritage Inventory, 2012                               | Corner awning<br>Source: Stephen Carrick Architects<br>September 2021                 |
|       |    |
| Faceted glass corner<br>Source: Stephen Carrick Architects<br>September 2021            | Pressed tin ceiling to awning<br>Source: Stephen Carrick Architects<br>September 2021 |
|      |   |
| Tiles surrounding windows<br>Source: Stephen Carrick Architects<br>September 2021       | Rear of building<br>Source: Stephen Carrick Architects<br>September 2021              |
|      |   |
| Courtyard and park to the north<br>Source: Stephen Carrick Architects<br>September 2021 |   |

**Heritage Item #**

|                                   |                                 |                                       |
|-----------------------------------|---------------------------------|---------------------------------------|
| MI Reference: 28<br>HCWA No: 3549 | Place Name: Poole Street Bridge | Other Name/s: West Northam Footbridge |
|                                   |                                 | Date of Review: October 2021          |



|  |  |
|--|--|
| Address: Poole Street (spanning over Avon River), Northam  | Lot No:<br>Property Key:<br>Plan Diagram:<br>Vol Folio:<br>Assess No: In front of A15190 |
| Locality: Northam  | GPS:   |
| Current Use: Former Bridge   | Original Use(s): Bridge  |
| <b>HERITAGE LISTINGS</b>   |  |
| Listings: State Register of Heritage Places (1996)<br>Statewide Large Timber Structures Survey (1998)<br>Classified National Trust (1995)  |  |
| <b>CONSTRUCTION</b>  |  |
| Date of Construction: 1917   |  |
| Architect / Builder: P.V. O'Brien (Engineer)   |  |
| Architectural Style:   |  |
| <b>PHYSICAL EVIDENCE</b>   |  |
| Description:<br>Poole Street Bridge is located at the northern end of Poole Street to the west of the Northam town centre. The footbridge crosses the Avon River and is approximately 150m long and 2m wide.<br><br>The structure consists of large timber piers supporting a system of timber bearers, joists and planks. The piers have diagonal cross bracing that is connected by large iron bolts. The walkway is enclosed by a rounded steel balustrade with a wire mesh infill. The bridge is in poor condition with several failed bearers to the southern end. Many timber planks have collapsed causing the bridge to be unusable. A Keep Out sign is located at each end.<br><br>Commemorative plaques and additional historical information are located at the southern end of the Bridge. The bridge is located along the Dornij Koorliny 'Walking Together' Track, which is a loop trail around Northam. |  |

|  |
|--|
| <p>The bridge is at the eastern most end of the 70km long multi use 'Kep Track' from Mundaring Weir to Northam. In its inception the Track was designed to continue across the bridge and terminate at the old Northam Railway Station; however, lack of funding has prevented this from happening.</p>  |
| <p>Condition: Poor</p>   |
| <p><b>HISTORICAL</b></p>   |
| <p><b>Notes:</b><br/>                 The bridge was associated with the development of the Goldfields Water Supply (G.W.S.) Scheme and is representative of wooden bridges built by the PWD in the early twentieth century. It was built to carry the G.W.S. pipeline and to provide a footbridge for the townspeople of Northam. It was the only major river crossing bridge built for the Goldfields Water Supply Scheme, and is a rare example in Western Australia of a structure designed to be both a pipeline bridge and a footbridge, although it is no longer used for either.</p> <p>The bridge linked two sides of the river, providing easy access to the Northam Railway Station, West Northam, and the nearby shops, hotel, houses and the railway workshop. In summer, Northam children used the bridge for access to Burlong Pool, and in the 1950s the bridge was well used by the many European migrants who temporarily settled at the Holden Migrant Camp.</p> <p>The pipeline was shifted in 1958 to a new bridge in Burn Street. As of September 2021, the bridge is not in use and closed off to the public due to poor condition.</p>   |
| <p>Theme: Community Services and Utilities</p>   |
| <p>Associations: Water Corporation</p>   |
| <p>Heritage Assessment or Conservation Plan:</p>   |
| <p>Public Access: No</p>   |
| <p><b>SIGNIFICANCE</b></p>   |
| <p>Level of Integrity: High</p>  |
| <p>Level of Authenticity: High</p>   |
| <p>Statement of Significance:</p>  |
| <p>Poole Street Bridge is of cultural heritage significance for the following reasons:</p> <ul style="list-style-type: none"> <li>• The place, in its tranquil setting of the Avon River at a point where the river is in a relatively natural state, has landmark value. The style of timber construction, its regularity and uniformity of timber piers and the line of its footway, is juxtaposed against the natural state of the river. The strong contrast between industrial structure and natural setting contributes to the landmark quality of the place.</li> <li>• The place is closely associated with the development of the Goldfields Water supply pipeline from Perth to Kalgoorlie in the first decades of the century.</li> <li>• The place is representative of the construction of the pipeline through Northam at a time when the town was experiencing growth to the east, and the consolidation of its importance as a major rural centre. It is associated with the growth in prosperity of the town and district of Northam.</li> <li>• The place is valued by the community as a visible reminder of the decades of use by the population of West Northam during Northam's period of growth in the first quarter of the century, and by many workers and children, including migrants stationed at the Holden Camp, in the 1950s.</li> <li>• The place is a rare structure in Western Australia. It is the only bridge built for the Goldfields Water Supply Scheme at a major river crossing which serves as both pipeline bridge and footbridge.</li> </ul> |
| <p>Level of Significance: Exceptional</p>  |
| <p>Heritage Category: 1</p>  |

| Additional Photographs  |   |
|---|---|
|        |   |
| <p>View from South end<br/>Source: Municipal Heritage Inventory<br/>2012</p>            | <p>South end<br/>Source: Stephen Carrick Architects<br/>October 2021</p>            |
|       |  |
| <p>Damage to timber pillars<br/>Source: Stephen Carrick Architects<br/>October 2021</p> | <p>Historical plaque<br/>Source: Stephen Carrick Architects<br/>October 2021</p>    |

### Attachment 3: Schedule of Submissions

#### Draft Heritage List Amendments

#### Schedule of Submissions

| No. | Name & Address  | Submission  | Heritage Consultant's Comments   | Officer's Comments  |
|-----|---|---|--|---|
| 1.  | Randle Beavis (landowner)<br>President, Grass Valley Progress Association | <p>I cannot find or recall any notification advising that our property was to be removed from the register as per the scheme provisions stated:</p> <ul style="list-style-type: none"> <li>Heritage List #17, MHI Ref 118, Inherit Ref 1848, Grass Valley Store (fmr), Assess No A246, Lot No. 11, 4 George St, Grass Valley.</li> </ul> <p>Monday 12/8/2019 I did advise planning that the current Grass Valley post office at Lot 8, 14 Carter St Grass Valley was erected in 1986 and therefore not really a heritage building.</p> <p>The former Post office at Lot 6, 10 Carter St Grass Valley should be included on the register in its place. No response was received on this advice however I note the 1986 post office is removed from the register.</p> <p>As President of the Grass Valley Progress Association, we have no record of notification that the following property was removed as well:</p> <ul style="list-style-type: none"> <li>Heritage List #4, MHI Ref 96, Inherit Ref the, Grass Valley Railway goods shed (fmr) Carter St Grass Valley, this is the only remaining building from the former Grass Valley railway station, was built prior to 1900 and should be included.</li> </ul> <p>Also note that the Grass Valley Hall opened by the Premier of WA in August 1921 is not listed. It is listed on the Heritage Council of WA as place number 01845.</p> <p>These places are noted in Shires approved Grass Valley Community Plan under item 2.4.9 History &amp; Culture.</p> <p>Heritage List #6, MHI Ref 114, Inherit Ref 10912, Clackline Refractory (fmr), Assess No A526, Lot No 19, House No 3 Clackline Road Clackline seems to be removed too.</p> | <p>We are unsure of the broader context for the response from Mr Beavis. We have identified below the information that we are aware of with regard to the six places raised in the submission. We would recommend that when further LHS review work is undertaken that a meeting is held with Mr Beavis to discuss these places as well as other places for further consideration for the LHS.</p> <p>Correspondence should be sent to Mr Beavis outlining the process going forward.</p> <ol style="list-style-type: none"> <li>Grass Valley Store</li> </ol> <p>MHI place record form appears to have little to no information and has been allocated a Management Category 4. It is recommended that further review of the place and Management Category should be undertaken as part of the next update of the Local Heritage Survey.</p> <ol style="list-style-type: none"> <li>Grass Valley Post Office Former</li> </ol> <p>MHI identifies the place as the 1986 tin shed. In 2019 the place was reviewed with additional information added. The place remains a Management Category 3. It is recommended that the place be further reviewed as part of the next update of the Local Heritage Survey.</p> <ol style="list-style-type: none"> <li>Grass Valley Railway Goods Shed</li> </ol> <p>MHI identified the place with a Management Category 3.</p> <ol style="list-style-type: none"> <li>Grass Valley Hall</li> </ol> <p>The place has not been included in any previous MHI. It is recommended that the place should be submitted for consideration during the next update of the Local Heritage Survey</p> <ol style="list-style-type: none"> <li>Clackline Refractory (fmr)</li> </ol> <p>MHI identified the place with a Management Category 4. The Shire of Northam Heritage List has been amended to only include places with Management Category 1 and 2. It is recommended that the place be further reviewed as part of the next update of the Local Heritage Survey.</p> <ol style="list-style-type: none"> <li>House No 3 Clackline Road, Clackline</li> </ol> <p>Could not locate any information for this place.</p> | <p>The Grass Valley properties listed in the submission are Category 3 properties on the Local Heritage Survey (formerly known as the Municipal Heritage Inventory) and were originally proposed for inclusion on the draft Heritage List (2020), which was based on a draft list compiled by a former heritage consultant a few years earlier.</p> <p>However, a review of the places by the Shire's current Heritage Consultant advised that the Heritage List should only include places listed in Categories 1 and 2 and that a review of the LHS should be conducted to determine the correctness of the categories and whether any new places should be identified and included.</p> <p>The review of the LHS is being conducted as part of the Shire's grant project to establish a strategic framework for heritage protection and further community consultation will occur as part of this process.</p> |
| 2.  | Daniel Stevens, Senior Planner<br>Water Corporation                       | <p>Thanks for the opportunity to comment on the proposed inclusion of the Water Corporation's property at 263 Fitzgerald St East, Northam in the Shire's local heritage list. Water Corporation has no objection to the proposal.</p>   | <p>Noted and no further comment.</p>   | <p>Noted.</p>   |

|    |  |  |   |  |
|----|--|--|---|--|
| 3. | Julian Donaldson, CEO<br>National Trust WA                   | <p>Thank you for advising us of the revisions to the LPS6 – Heritage List.</p> <p>The National Trust has a Management Order over the Poole Street Bridge which is a part of the Trust's Golden Pipeline Heritage Trail. The Bridge is listed on the State Register of Heritage Places and included on the Shire's Heritage List.</p> <p>The National Trust is comfortable with the proposed changes to the listing. We suggest one small addition at the end of the 'Physical Evidence' section:</p> <p>"The bridge is at the eastern most end of the 70km long multi use 'Keap Track' from Mundaring Weir to Northam. In its inception the Track was designed to continue across the bridge and terminate at the old Northam railway station however lack of funding has prevented this from happening."</p>  | Place Record Form has been amended as per comments.   | Agree. Place record to be amended.   |
| 4. | Maria Girak (landowner)<br>16 Gordon Street, Northam         | <p>I refer to the Shire of Northam Public Notice, 24 May 2022. Proposed Amendments to the Heritage List. My residential property, the former Masonic Hall "Stone Court" at 16 Gordon Street, Northam has been listed on the Proposed Amended Heritage List #75.</p> <p>Assess No: A15461<br/>M Reference: 58<br/>HCWA No: 10890</p> <p>The property at 16 Gordon Street, Northam WA 6401 is on two separate titles, Lot 5 and Lot 6 on Plan 647 Vol Folio: 1498/380.</p> <p>The building subjected to the Heritage listing is situated on Lot 6 of the Certificate of Title</p> <p>I welcome the consideration of placing the former Masonic Hall building located on Lot 6 under heritage protection, and I have no objection for the building to be added to the register.</p> <p>However, Lot 5 is an unimproved block, and has no heritage significance. I do not consent to Lot 5 being added to the Heritage Register. I request that the Shire of Northam remove reference to Lot 5 on Plan 647 Vol Folio: 1498/380, 16 Gordon Street, Northam WA from the Shire of Northam Heritage List Register, and every other document and record relevant to heritage listing.</p> | We have reviewed the curtilage for 16 Gordon Street, Northam. In our opinion both Lots 5 and 6 should be included in the listing in the Local Heritage Survey. Any future development to the property will need to be cognisant of the cultural heritage values of the place.       | Agree. Aerial photographs indicate that a portion of the building encroaches onto Lot 5 together with a rear addition and stone fencing. It is therefore appropriate that both lots are included on the listing. |
| 5. | Les Norrish (landowner)<br>178 Fitzgerald Street,<br>Northam | <p>Our building situated at 178 Fitzgerald St Northam is currently noted on the Shire records as "Northam Travel".</p> <p>We would like to name the building something more appropriate – like say, Coles Corner or G J Coles – the original Tenants.</p> <p>We will make enquires with the appropriate parties. Any views you have to improve the historic character of this building would be appreciated.</p>   | <p>Agree with a proposed name amendment.</p> <p>Suggest liaison with Mr Norrish with regard to the name change to G. J. Coles and Co., Limited (fmr).</p> <p>Northam Travel to be included under other names.</p> <p>Place Record Form has been amended to reflect this change.</p> | Agree. Place record to be amended.   |

## 13.4 CORPORATE SERVICES

### 13.4.1 Accounts & Statements of Accounts 1 July 2022 to 31 July 2022

|   |  |
|---|--|
| <b>File Reference:</b>                  | 2.1.3.4  |
| <b>Reporting Officer:</b>               | Louise Harris, Creditors Officer                 |
| <b>Responsible Officer:</b>             | Colin Young, Executive Manager Corporate Service |
| <b>Officer Declaration of Interest:</b> | Nil  |
| <b>Voting Requirement:</b>              | Simple Majority                                  |
| <b>Press release to be issued:</b>      | No   |

#### BRIEF

For Council to receive the accounts for the period from 1 July 2022 to 31 July 2022.

#### ATTACHMENTS

Attachment 1: Accounts & Statements of Accounts – July 2022.  
Attachment 2: Declaration.

---

#### A. BACKGROUND / DETAILS

The reporting of monthly financial information is a requirement under section 6.4 of the Local Government Act 1995, and Regulation 34 of the Local Government (Financial Management) Regulations.

Pursuant to Financial Management Regulation 13, a list of payments made from Municipal and Trust accounts is required to be presented to Council on a periodical basis. These details are included as Attachment 1. In accordance with Financial Management Regulation 12, the Chief Executive Officer has delegated authority to make these payments.

#### B. CONSIDERATIONS

##### B.1 Strategic Community / Corporate Business Plan

Theme Area 6: Governance & Leadership.

Outcome 6.3: The Shire of Northam council is a sustainable, responsive, innovative and transparent organisation.

##### B.2 Financial / Resource Implications

Payments of accounts are in accordance with Council's 2022/23 Budget.



**B.3 Legislative Compliance**

Section 6.4 & 6.26(2) (g) of the Local Government Act 1995.  
 Financial Management Regulations 2007, Regulation 12 & 13.

**B.4 Policy Implications**

Nil.

**B.5 Stakeholder Engagement / Consultation**

Not applicable.

**B.6 Risk Implications**

| Risk Category        | Description   | Rating<br>(consequence<br>x likelihood) | Mitigation Action   |
|----------------------|---|---|---|
| Financial            | Figures not reflecting the true financial situation | Rare (2) x<br>Medium (3) =<br>Low (3)   | There are processes in place to show compliance with relevant legislation |
| Health & Safety      | N/A   | N/A                                     | N/A   |
| Reputation           | N/A   | N/A                                     | N/A   |
| Service Interruption | N/A   | N/A                                     | N/A   |
| Compliance           | Report not being accepted by Council                | Rare (2) x<br>Medium (3) =<br>Low (3)   | There are processes in place to show compliance with relevant legislation |
| Property             | N/A   | N/A                                     | N/A   |
| Environment          | N/A   | N/A                                     | N/A   |

**B.7 Natural Environment Considerations**

Nil.

**C. OFFICER'S COMMENT**

The matter of Council 'supporting local business' has been raised over a long period. To assist in providing a greater understanding of the purchasing patterns of the Shire of Northam, the following graph summarises the payments made locally for the month of July 2022:

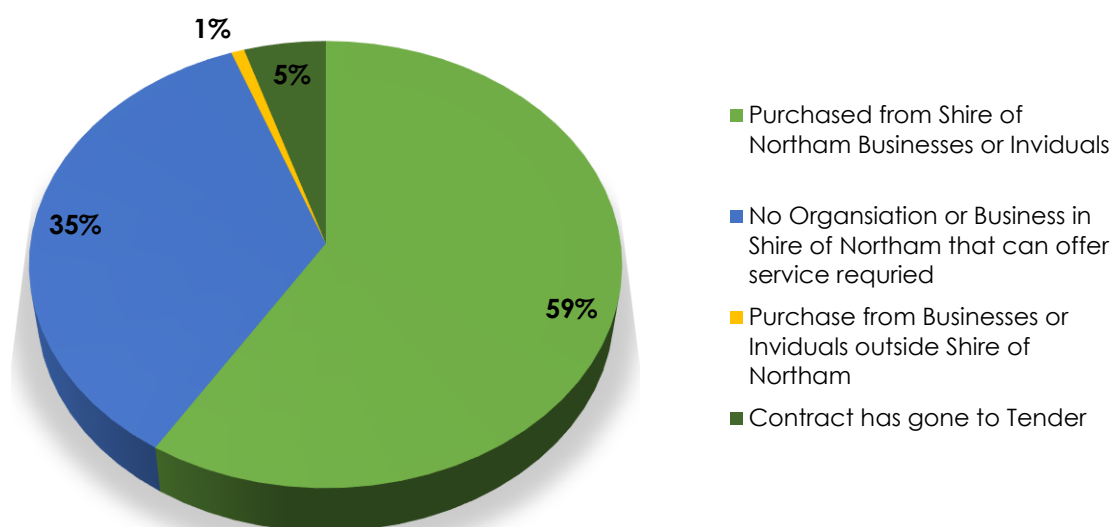

#### RECOMMENDATION

That Council receive the payments for the period 1 July 2022 to 31 July 2022, as listed:

- Municipal Fund payment cheque numbers 35509 to 35515 Total \$35,158.28.
- Municipal Fund EFT44134 to EFT44460 Total \$1,922,165.42.
- Direct Debits Total \$92,241.22.
- Payroll Total \$450,983.16

**TOTAL: \$2,500,548.08**

Which have been made in accordance with the delegated authority reference number (M/F/F/Regs LGA 1995 S5.42).

### Attachment 1: Accounts & Statements of Accounts – July 2022

Date: 01/08/2022  
Time: 9:17:37AM

Shire of Northam

USER: Louise Harris  
PAGE: 1

| Cheque /EFT No        | Date       | Name                   | Invoice Description  | Bank Code | INV Amount | Amount    |
|-----------------------|------------|------------------------|--|-----------|------------|-----------|
| 35509                 | 12/07/2022 | COMMISSIONER OF POLICE | NORTHAM BILYA FESTIVAL 2022 - ROAD CLOSURE FEE   | 1         |            | 85.70     |
| INV MB 06006/07/2022  |            | COMMISSIONER OF POLICE | NORTHAM BILYA FESTIVAL 2022 - ROAD CLOSURE FEE   | 1         | 85.70      |           |
| 35510                 | 12/07/2022 | FRANCES HELEN DOYE     | RATES CREDIT REFUND FOR ASSESSMENT A12572  | 1         |            | 491.03    |
| INV A1257230/06/2022  |            | FRANCES HELEN DOYE     | RATES CREDIT REFUND FOR ASSESSMENT A12572  |           | 491.03     |           |
| 35511                 | 12/07/2022 | PETTY CASH             | PETTY CASH - NORTHAM REC & POOL - BUNNINGS / NEWPOWER / NORTHAM BETTA HOMES / COLES / DUNNINGS / SHOE REPAIR MAN / RET DOT | 1         |            | 133.75    |
| INV DE 300630/06/2022 |            | PETTY CASH             | PETTY CASH - NORTHAM REC & POOL - BUNNINGS / NEWPOWER / NORTHAM BETTA HOMES / COLES / DUNNINGS / SHOE REPAIR MAN / RET DOT | 1         | 133.75     |           |
| 35512                 | 12/07/2022 | SHIRE OF NORTHAM       | MONTHLY BSL FEES COLLECTED FOR THE BUILDING COMMISSION FOR THE MONTH OF JUNE 2022  | 1         |            | 168.25    |
| INV T1079 08/07/2022  |            | SHIRE OF NORTHAM       | PAYMENT FOR COLLECTION OF BCITF FEES ON BEHALF OF THE CONSTRUCTION TRAINING FUND FOR THE MONTH OF JUNE 2022                | 1         | 8.25       |           |
| INV T1080 08/07/2022  |            | SHIRE OF NORTHAM       | MONTHLY BSL FEES COLLECTED FOR THE BUILDING COMMISSION FOR THE MONTH OF JUNE 2022  | 1         | 160.00     |           |
| 35513                 | 12/07/2022 | WATER CORPORATION      | 9007868583 WUNDOWIE SWIMMING POOL - 19/04/2022 to 13/06/2022   | 1         |            | 2,438.82  |
| INV 900786815/06/2022 |            | WATER CORPORATION      | 9007868583 WUNDOWIE SWIMMING POOL - 19/04/2022 to 13/06/2022   |           | 2,124.48   |           |
| INV 900786915/06/2022 |            | WATER CORPORATION      | 9007869121 WUNDOWIE LIBRARY & GARDENS - 19/04/2022 to 13/06/2022   |           | 314.34     |           |
| 35514                 | 22/07/2022 | SHIRE OF NORTHAM       | 12 MTHS REGISTRATION FOR N460 - 01/08/2022-31/07/2023  | 1         |            | 23,861.30 |
| INV N40157 20/06/2022 |            | SHIRE OF NORTHAM       | 12 MTHS REGISTRATION FOR N40157 - 01/08/2022-31/07/2023  |           | 24.85      |           |
| INV N10863 20/06/2022 |            | SHIRE OF NORTHAM       | 12 MTHS REGISTRATION FOR N10863 - 01/08/2022-31/07/2023  |           | 82.85      |           |
| INV N.017 20/06/2022  |            | SHIRE OF NORTHAM       | 12 MTHS REGISTRATION FOR N.017 - 01/08/2022-31/07/2023   |           | 82.85      |           |
| INV 1TNU4820/06/2022  |            | SHIRE OF NORTHAM       | 12 MTHS REGISTRATION FOR 1TNU484 -01/08/2022-31/07/2023  |           | 24.85      |           |

Date: 01/08/2022  
Time: 9:17:37AM

Shire of Northam

USER: Louise Harris  
PAGE: 2 10

| Cheque /EFT No | Date       | Name             | Invoice Description                                       | Bank Code | INV Amount | Amount |
|----------------|------------|------------------|---|-----------|------------|--------|
| INV N460       | 20/06/2022 | SHIRE OF NORTHAM | 12 MTHS REGISTRATION FOR N460 - 01/08/2022-31/07/2023     |           | 436.40     |        |
| INV 1GZQ71     | 20/06/2022 | SHIRE OF NORTHAM | 12 MTHS REGISTRATION FOR 1GZQ718 - 01/08/2022-31/07/2023  |           | 406.70     |        |
| INV N.4100     | 20/06/2022 | SHIRE OF NORTHAM | 12 MTHS REGISTRATION FOR N.4100 - 01/08/2022-31/07/2023   |           | 406.70     |        |
| INV N.4099     | 20/06/2022 | SHIRE OF NORTHAM | 12 MTHS REGISTRATION FOR N.4099 -01/08/2022-31/07/2023    |           | 406.70     |        |
| INV KILLAR20   | 20/06/2022 | SHIRE OF NORTHAM | 12 MTHS REGISTRATION FOR KILLARA - 01/08/2022-31/07/2023  |           | 436.40     |        |
| INV KILLAR20   | 20/06/2022 | SHIRE OF NORTHAM | 12 MTHS REGISTRATION FOR KILLARA3 - 01/08/2022-31/07/2023 |           | 436.40     |        |
| INV N.002      | 20/06/2022 | SHIRE OF NORTHAM | 12 MTHS REGISTRATION FOR N.002 -01/08/2022-31/07/2023     |           | 263.65     |        |
| INV 8TF590     | 20/06/2022 | SHIRE OF NORTHAM | 12 MTHS REGISTRATION FOR 8TF590 - 01/08/2022-31/07/2023   |           | 24.85      |        |
| INV N10996     | 20/06/2022 | SHIRE OF NORTHAM | 12 MTHS REGISTRATION FOR N10996 - 01/08/2022-31/07/2023   |           | 406.70     |        |
| INV N11063     | 20/06/2022 | SHIRE OF NORTHAM | 12 MTHS REGISTRATION FOR N11063 - 01/08/2022-31/07/2023   |           | 82.85      |        |
| INV 1TQM5      | 20/06/2022 | SHIRE OF NORTHAM | 12 MTHS REGISTRATION FOR 1TQM573 -01/08/2022-31/07/2023   |           | 24.85      |        |
| INV 1TQM5      | 20/06/2022 | SHIRE OF NORTHAM | 12 MTHS REGISTRATION FOR 1TQM574 - 01/08/2022-31/07/2023  |           | 24.85      |        |
| INV N.4174     | 20/06/2022 | SHIRE OF NORTHAM | 12 MTHS REGISTRATION FOR N.4174 -01/08/2022-31/07/2023    |           | 82.85      |        |
| INV N11142     | 20/06/2022 | SHIRE OF NORTHAM | 12 MTHS REGISTRATION FOR N11142 -01/08/2022-31/07/2023    |           | 406.70     |        |
| INV N40090     | 20/06/2022 | SHIRE OF NORTHAM | 12 MTHS REGISTRATION FOR N40090 - 01/08/2022-31/07/2023   |           | 24.85      |        |
| INV 1TRA5020   | 20/06/2022 | SHIRE OF NORTHAM | 12 MTHS REGISTRATION FOR 1TRA502 - 01/08/2022-31/07/2023  |           | 24.85      |        |
| INV N11164     | 20/06/2022 | SHIRE OF NORTHAM | 12 MTHS REGISTRATION FOR N11164 - 01/08/2022-31/07/2023   |           | 406.70     |        |
| INV N11267     | 20/06/2022 | SHIRE OF NORTHAM | 12 MTHS REGISTRATION FOR N11267 - 01/08/2022-31/07/2023   |           | 406.70     |        |
| INV N.5380     | 20/06/2022 | SHIRE OF NORTHAM | 12 MTHS REGISTRATION FOR N.5380 - 01/08/2022-31/07/2023   |           | 24.85      |        |

Ordinary Council Meeting Agenda  
17 August 2022



Date: 01/08/2022  
Time: 9:17:37AM

Shire of Northam

USER: Louise Harris  
PAGE: 3

| Cheque /EFT No | Date       | Name             | Invoice Description                                      | Bank Code | INV Amount | Amount |
|----------------|------------|------------------|--|-----------|------------|--------|
| INV N11187     | 20/06/2022 | SHIRE OF NORTHAM | 12 MTHS REGISTRATION FOR N11187 - 01/08/2022-31/07/2023  |           | 406.70     |        |
| INV N11291     | 20/06/2022 | SHIRE OF NORTHAM | 12 MTHS REGISTRATION FOR N11291 - 01/08/2022-31/07/2023  |           | 406.70     |        |
| INV 1TRB6720   | 20/06/2022 | SHIRE OF NORTHAM | 12 MTHS REGISTRATION FOR 1TRB674 - 01/08/2022-31/07/2023 |           | 24.85      |        |
| INV N.15088    | 20/06/2022 | SHIRE OF NORTHAM | 12 MTHS REGISTRATION FOR N.15088 - 01/08/2022-31/07/2023 |           | 24.85      |        |
| INV N577       | 20/06/2022 | SHIRE OF NORTHAM | 12 MTHS REGISTRATION FOR N577 -01/08/2022-31/07/2023     |           | 406.70     |        |
| INV N642       | 20/06/2022 | SHIRE OF NORTHAM | 12 MTHS REGISTRATION FOR N642 - 01/08/2022-31/07/2023    |           | 263.65     |        |
| INV N.003      | 20/06/2022 | SHIRE OF NORTHAM | 12 MTHS REGISTRATION FOR N.003 -01/08/2022-31/07/2023    |           | 406.70     |        |
| INV N.007      | 20/06/2022 | SHIRE OF NORTHAM | 12 MTHS REGISTRATION FOR N.007 -01/08/2022-31/07/2023    |           | 406.70     |        |
| INV N.1709     | 20/06/2022 | SHIRE OF NORTHAM | 12 MTHS REGISTRATION FOR N.1709 - 01/08/2022-31/07/2023  |           | 406.70     |        |
| INV N.1508020  | 20/06/2022 | SHIRE OF NORTHAM | 12 MTHS REGISTRATION FOR N.15080 - 01/08/2022-31/07/2023 |           | 24.85      |        |
| INV N.006      | 20/06/2022 | SHIRE OF NORTHAM | 12 MTHS REGISTRATION FOR N.006 -01/08/2022-31/07/2023    |           | 82.85      |        |
| INV N.3505     | 20/06/2022 | SHIRE OF NORTHAM | 12 MTHS REGISTRATION FOR N.3505 - 01/08/2022-31/07/2023  |           | 263.65     |        |
| INV 1TSH2720   | 20/06/2022 | SHIRE OF NORTHAM | 12 MTHS REGISTRATION FOR 1TSH272 - 01/08/2022-31/07/2023 |           | 24.85      |        |
| INV N11469     | 20/06/2022 | SHIRE OF NORTHAM | 12 MTHS REGISTRATION FOR N11469 - 01/08/2022-31/07/2023  |           | 406.70     |        |
| INV 1TSO1820   | 20/06/2022 | SHIRE OF NORTHAM | 12 MTHS REGISTRATION FOR 1TSO183 -01/08/2022-31/07/2023  |           | 24.85      |        |
| INV N.4346     | 20/06/2022 | SHIRE OF NORTHAM | 12 MTHS REGISTRATION FOR N.4346 - 01/08/2022-31/07/2023  |           | 263.65     |        |
| INV N.001      | 20/06/2022 | SHIRE OF NORTHAM | 12 MTHS REGISTRATION FOR N.001 -01/08/2022-31/07/2023    |           | 82.85      |        |
| INV N11120     | 20/06/2022 | SHIRE OF NORTHAM | 12 MTHS REGISTRATION FOR N11120 - 01/08/2022-31/07/2023  |           | 436.40     |        |
| INV N79        | 20/06/2022 | SHIRE OF NORTHAM | 12 MTHS REGISTRATION FOR N79 -01/08/2022-31/07/2023      |           | 406.70     |        |
| INV 1TTO4120   | 20/06/2022 | SHIRE OF NORTHAM | 12 MTHS REGISTRATION FOR 1TTO411 -01/08/2022-31/07/2023  |           | 24.85      |        |

Date: 01/08/2022  
Time: 9:17:37AM

Shire of Northam

USER: Louise Harris  
PAGE: 4 10

| Cheque /EFT<br>No     | Date | Name             | Invoice Description  | Bank<br>Code | INV<br>Amount | Amount |
|-----------------------|------|------------------|--|--------------|---------------|--------|
| INV KILLAR20/06/2022  |      | SHIRE OF NORTHAM | 12 MTHS REGISTRATION FOR KILLARA4 -<br>01/08/2022-31/07/2023 |              | 436.40        |        |
| INV N.3856 20/06/2022 |      | SHIRE OF NORTHAM | 12 MTHS REGISTRATION FOR N40157 -<br>01/08/2022-31/07/2023   |              | 263.65        |        |
| INV N10759 20/06/2022 |      | SHIRE OF NORTHAM | 12 MTHS REGISTRATION FOR N10759 -<br>01/08/2022-31/07/2023   |              | 406.70        |        |
| INV N.4012 20/06/2022 |      | SHIRE OF NORTHAM | 12 MTHS REGISTRATION FOR N.4012<br>-01/08/2022-31/07/2023    |              | 406.70        |        |
| INV N.009 20/06/2022  |      | SHIRE OF NORTHAM | 12 MTHS REGISTRATION FOR N.009 -01/08/2022-31/07/2023        |              | 436.40        |        |
| INV N.4013 20/06/2022 |      | SHIRE OF NORTHAM | 12 MTHS REGISTRATION FOR N.4013 -<br>01/08/2022-31/07/2023   |              | 406.70        |        |
| INV KILLAR20/06/2022  |      | SHIRE OF NORTHAM | 12 MTHS REGISTRATION FOR KILLARA2 -<br>01/08/2022-31/07/2023 |              | 436.40        |        |
| INV N.004 20/06/2022  |      | SHIRE OF NORTHAM | 12 MTHS REGISTRATION FOR N.004 -01/08/2022-31/07/2023        |              | 82.85         |        |
| INV N254 20/06/2022   |      | SHIRE OF NORTHAM | 12 MTHS REGISTRATION FOR N254 -01/08/2022-31/07/2023         |              | 436.40        |        |
| INV N10721 20/06/2022 |      | SHIRE OF NORTHAM | 12 MTHS REGISTRATION FOR N10721 -<br>01/08/2022-31/07/2023   |              | 406.70        |        |
| INV N11184 20/06/2022 |      | SHIRE OF NORTHAM | 12 MTHS REGISTRATION FOR N11184 -<br>01/08/2022-31/07/2023   |              | 406.70        |        |
| INV N.4468 20/06/2022 |      | SHIRE OF NORTHAM | 12 MTHS REGISTRATION FOR N.4468 -<br>01/08/2022-31/07/2023   |              | 82.85         |        |
| INV N.3862 20/06/2022 |      | SHIRE OF NORTHAM | 12 MTHS REGISTRATION FOR N.3862 -<br>01/08/2022-31/07/2023   |              | 82.85         |        |
| INV N11069 20/06/2022 |      | SHIRE OF NORTHAM | 12 MTHS REGISTRATION FOR N11069 -<br>01/08/2022-31/07/2023   |              | 436.40        |        |
| INV N10734 20/06/2022 |      | SHIRE OF NORTHAM | 12 MTHS REGISTRATION FOR N10734<br>-01/08/2022-31/07/2023    |              | 436.40        |        |
| INV N11196 20/06/2022 |      | SHIRE OF NORTHAM | 13 MTHS REGISTRATION FOR N11196 -<br>01/08/2022-31/07/2023   |              | 436.40        |        |
| INV N11657 20/06/2022 |      | SHIRE OF NORTHAM | 15 MTHS REGISTRATION FOR N11657 -<br>01/08/2022-31/07/2023   |              | 406.70        |        |
| INV N.4487 20/06/2022 |      | SHIRE OF NORTHAM | 12 MTHS REGISTRATION FOR N.4487<br>-01/08/2022-31/07/2023    |              | 406.70        |        |
| INV 1GZZ1220/06/2022  |      | SHIRE OF NORTHAM | 12 MTHS REGISTRATION FOR 1GZZ129 -<br>01/08/2022-31/07/2023  |              | 82.85         |        |

Date: 01/08/2022  
Time: 9:17:37AM

Shire of Northam

USER: Louise Harris  
PAGE: 5 5

| Cheque/EFT No | Date       | Name             | Invoice Description   | Bank Code | INV Amount | Amount |
|---------------|------------|------------------|---|-----------|------------|--------|
| INV N.4490    | 20/06/2022 | SHIRE OF NORTHAM | 12 MTHS REGISTRATION FOR N.4490<br>-01/08/2022-31/07/2023   |           | 406.70     |        |
| INV N11684    | 20/06/2022 | SHIRE OF NORTHAM | 12 MTHS REGISTRATION FOR N11684<br>-01/08/2022-31/07/2023   |           | 436.40     |        |
| INV N.3805    | 20/06/2022 | SHIRE OF NORTHAM | 12 MTHS REGISTRATION FOR N.3805 -<br>01/08/2022-31/07/2023  |           | 406.70     |        |
| INV N.4096    | 20/06/2022 | SHIRE OF NORTHAM | 12 MTHS REGISTRATION FOR N.4096 -<br>01/08/2022-31/07/2023  |           | 406.70     |        |
| INV N.3871    | 20/06/2022 | SHIRE OF NORTHAM | 12 MTHS REGISTRATION FOR N.3871 -<br>01/08/2022-31/07/2023  |           | 82.85      |        |
| INV N11206    | 20/06/2022 | SHIRE OF NORTHAM | 12 MTHS REGISTRATION FOR N11206 -<br>01/08/2022-31/07/2023  |           | 406.70     |        |
| INV 1TOV60    | 20/06/2022 | SHIRE OF NORTHAM | 12 MTHS REGISTRATION FOR 1TOV603 -<br>01/08/2022-31/07/2023 |           | 24.85      |        |
| INV 1TAA11    | 20/06/2022 | SHIRE OF NORTHAM | 12 MTHS REGISTRATION FOR 1TAA111 -<br>01/08/2022-31/07/2023 |           | 24.85      |        |
| INV N.4531    | 20/06/2022 | SHIRE OF NORTHAM | 12 MTHS REGISTRATION FOR N.4531 -<br>01/08/2022-31/07/2023  |           | 82.85      |        |
| INV N11363    | 20/06/2022 | SHIRE OF NORTHAM | 12 MTHS REGISTRATION FOR N11363 -<br>01/08/2022-31/07/2023  |           | 436.40     |        |
| INV N11114    | 20/06/2022 | SHIRE OF NORTHAM | 12 MTHS REGISTRATION FOR N11114 -<br>01/08/2022-31/07/2023  |           | 436.40     |        |
| INV N.3433    | 20/06/2022 | SHIRE OF NORTHAM | 12 MTHS REGISTRATION FOR N.3433 -<br>01/08/2022-31/07/2023  |           | 436.40     |        |
| INV N11084    | 20/06/2022 | SHIRE OF NORTHAM | 12 MTHS REGISTRATION FOR N11084 -<br>01/08/2022-31/07/2023  |           | 406.70     |        |
| INV 1THT84    | 20/06/2022 | SHIRE OF NORTHAM | 12 MTHS REGISTRATION FOR 1THT841 -<br>01/08/2022-31/07/2023 |           | 24.85      |        |
| INV 1TKK95    | 20/06/2022 | SHIRE OF NORTHAM | 12 MTHS REGISTRATION FOR 1TKK954 -<br>01/08/2022-31/07/2023 |           | 24.85      |        |
| INV N.5477    | 20/06/2022 | SHIRE OF NORTHAM | 12 MTHS REGISTRATION FOR N.5477 -<br>01/08/2022-31/07/2023  |           | 24.85      |        |
| INV 1TLA33    | 20/06/2022 | SHIRE OF NORTHAM | 12 MTHS REGISTRATION FOR 1TLA331 -<br>01/08/2022-31/07/2023 |           | 24.85      |        |
| INV N.4259    | 20/06/2022 | SHIRE OF NORTHAM | 12 MTHS REGISTRATION FOR N.4259<br>-01/08/2022-31/07/2023   |           | 406.70     |        |

Ordinary Council Meeting Agenda  
17 August 2022



Date: 01/08/2022  
Time: 9:17:37AM

Shire of Northam

USER: Louise Harris  
PAGE: 6 6

| Cheque /EFT No | Date       | Name              | Invoice Description   | Bank Code | INV Amount | Amount   |
|----------------|------------|-------------------|---|-----------|------------|----------|
| INV N11254     | 20/06/2022 | SHIRE OF NORTHAM  | 12 MTHS REGISTRATION FOR N11254 - 01/08/2022-31/07/2023             |           | 406.70     |          |
| INV N.4098     | 20/06/2022 | SHIRE OF NORTHAM  | 12 MTHS REGISTRATION FOR N.4098 - 01/08/2022-31/07/2023             |           | 436.40     |          |
| INV N9166      | 20/06/2022 | SHIRE OF NORTHAM  | 12 MTHS REGISTRATION FOR N9166 -01/08/2022-31/07/2023               |           | 82.85      |          |
| INV N11131     | 20/06/2022 | SHIRE OF NORTHAM  | 12 MTHS REGISTRATION FOR N11131 -01/08/2022-31/07/2023              |           | 436.40     |          |
| INV N.3333     | 20/06/2022 | SHIRE OF NORTHAM  | 12 MTHS REGISTRATION FOR N.3333 - 01/08/2022-31/07/2023             |           | 406.70     |          |
| INV 1TVZ2420   | 20/06/2022 | SHIRE OF NORTHAM  | 12 MTHS REGISTRATION FOR 1TVZ247 - 01/08/2022-31/07/2023            |           | 24.85      |          |
| INV N10938     | 20/06/2022 | SHIRE OF NORTHAM  | 12 MTHS REGISTRATION FOR N10938 -01/08/2022-31/07/2023              |           | 406.70     |          |
| INV N9467      | 20/06/2022 | SHIRE OF NORTHAM  | 12 MTHS REGISTRATION FOR N9467 - 01/08/2022-31/07/2023              |           | 436.40     |          |
| INV 1TLJ76720  | 20/06/2022 | SHIRE OF NORTHAM  | 12 MTHS REGISTRATION FOR 1TLJ767 - 01/08/2022-31/07/2023            |           | 24.85      |          |
| INV N.2116     | 20/06/2022 | SHIRE OF NORTHAM  | 12 MTHS REGISTRATION FOR N.2116 - 01/08/2022-31/07/2023             |           | 24.85      |          |
| INV N.1520420  | 20/06/2022 | SHIRE OF NORTHAM  | 12 MTHS REGISTRATION FOR N.15204 -01/08/2022-31/07/2023             |           | 24.85      |          |
| INV N.4651     | 20/06/2022 | SHIRE OF NORTHAM  | 12 MTHS REGISTRATION FOR N.4651 -01/08/2022-31/07/2023              |           | 406.70     |          |
| 35515          | 22/07/2022 | WATER CORPORATION | 9007913575 STANDPIPE - PEEL TCE - 19/05/2022 to 13/07/2022          | 1         |            | 7,979.43 |
| INV 900794505  | 07/2022    | WATER CORPORATION | 9007945104 KATRINE TOILETS - C2/05/2022 to 03/07/2022               |           | 16.37      |          |
| INV 901115405  | 07/2022    | WATER CORPORATION | 9011154743 COMMONAGE - C2/05/2022 to 03/07/2022                     |           | 650.19     |          |
| INV 900790107  | 07/2022    | WATER CORPORATION | 9007901603 RAILWAY MUSEUM - 05/05/2022 to 05/07/2022                |           | 171.51     |          |
| INV 900872907  | 07/2022    | WATER CORPORATION | 9008729788 SHIRE ADMINISTRATION BUILDING - 05/05/2022 to 05/07/2022 |           | 215.31     |          |
| INV 900789908  | 07/2022    | WATER CORPORATION | 9007899961 GIRL GUIDES HALL - 05/05/2022 to 06/07/2022              |           | 72.27      |          |
| INV 900790308  | 07/2022    | WATER CORPORATION | 9007903799 TOWN & LESSER HALL - 06/05/2022 to 06/07/2022            |           | 370.12     |          |



Ordinary Council Meeting Agenda  
17 August 2022



Date: 01/08/2022  
Time: 9:17:37AM

Shire of Northam

USER: Louise Harris  
PAGE: 7 5

| Cheque/EFT No         | Date       | Name              | Invoice Description   | Bank Code | INV Amount | Amount    |
|-----------------------|------------|-------------------|---|-----------|------------|-----------|
| INV 900790613/07/2022 |            | WATER CORPORATION | 9007906746 MEN'S SHED / OLD FIRE STATION - 17/05/2022 to 11/07/2022                 |           | 129.58     |           |
| INV 900790613/07/2022 |            | WATER CORPORATION | 9007906922 OLD INFANT HEALTH CLINIC - 16/05/2022 to 11/07/2022                      |           | 112.96     |           |
| INV 900790813/07/2022 |            | WATER CORPORATION | 9007908063 OLD POST OFFICE BUILDING - 16/05/2022 to 11/07/2022                      |           | 326.07     |           |
| INV 900790813/07/2022 |            | WATER CORPORATION | 9007908071 OLD GIRLS SCHOOL - 16/05/2022 to 11/07/2022                              |           | 72.27      |           |
| INV 900790913/07/2022 |            | WATER CORPORATION | 9007909752 YOUTH PARK - 17/05/2022 to 11/07/2022                                    |           | 40.94      |           |
| INV 900790913/07/2022 |            | WATER CORPORATION | 9007909787 JUBILEE OVAL - 17/05/2022 to 11/07/2022                                  |           | 693.25     |           |
| INV 900790414/07/2022 |            | WATER CORPORATION | 9007904089 NORTHAM LIBRARY - 17/05/2022 to 12/07/2022                               |           | 88.64      |           |
| INV 900790714/07/2022 |            | WATER CORPORATION | 9007907431 BERNARD PARK - 17/05/2022 to 12/07/2022                                  |           | 1,096.14   |           |
| INV 900790714/07/2022 |            | WATER CORPORATION | 9007907458 BERNARD PARK SUB METER - 17/05/2022 to 12/07/2022                        |           | 94.35      |           |
| INV 900792914/07/2022 |            | WATER CORPORATION | 9007929497 AVON MALL - 17/05/2022 to 12/07/2022                                     |           | 161.01     |           |
| INV 900790314/07/2022 |            | WATER CORPORATION | 9007903879 108 WELLINGTON ST - ST JOHN PUBLIC OPEN SPACE - 17/05/2022 to 11/07/2022 |           | 56.71      |           |
| INV 901107014/07/2022 |            | WATER CORPORATION | 9011070427 RIVERSEDGE CAFE (SNACKBAR) - WASTE - 01/07/2022 to 31/08/2022            |           | 236.56     |           |
| INV 900790314/07/2022 |            | WATER CORPORATION | 9007903991 ST JOHNS HALL - 17/05/2022 to 11/07/2022                                 |           | 151.91     |           |
| INV 900790414/07/2022 |            | WATER CORPORATION | 9007904003 MEMORIAL HALL - 17/05/2022 to 11/07/2022                                 |           | 319.86     |           |
| INV 900790414/07/2022 |            | WATER CORPORATION | 9007904062 OLD TOWN BUILDING - 17/05/2022 to 12/07/2022                             |           | 80.21      |           |
| INV 900791315/07/2022 |            | WATER CORPORATION | 9007913102 NORTHAM DEPOT - BYFIELD ST - 19/05/2022 to 13/07/2022                    |           | 166.47     |           |
| INV 900791315/07/2022 |            | WATER CORPORATION | 9007913567 NORTHAM DEPOT - PEEL ST - 19/05/2022 to 13/07/2022                       |           | 292.00     |           |
| INV 900791315/07/2022 |            | WATER CORPORATION | 9007913575 STANDPIPE - PEEL TCE - 19/05/2022 to 13/07/2022                          |           | 1,910.30   |           |
| INV 900791718/07/2022 |            | WATER CORPORATION | 9007917058 CEMETERY - 19/05/2022 to 14/07/2022                                      |           | 406.62     |           |
| INV 901247518/07/2022 |            | WATER CORPORATION | 9012475784 GARDEN TAYLOR ST - 01/07/2022 to 31/08/2022                              |           | 47.81      |           |
| EFT44134              | 04/07/2022 | WCP CIVIL PTY LTD | REFUND - BPAY PAYMENT 29/06/22- OVERPAYMENT OF INVOICE 26804                        | 1         |            | 26,804.00 |

Date: 01/08/2022  
Time: 9:17:37AM

Shire of Northam

USER: Louise Harris  
PAGE: 8 6

| Cheque /EFT No        | Date       | Name  | Invoice Description  | Bank Code | INV Amount | Amount    |
|-----------------------|------------|---|--|-----------|------------|-----------|
| INV 26804             | 17/06/2022 | WCP CIVIL PTY LTD                           | REFUND - BPAY PAYMENT 29/06/22- OVERPAYMENT OF INVOICE 26804   | 1         | 26,804.00  |           |
| EFT44135              | 05/07/2022 | ACES ANIMAL CARE EQUIPMENT SERVICES PTY LTD | CSS-C SHIELD SPRAY   | 1         |            | 482.15    |
| INV 000359423/06/2022 |            | ACES ANIMAL CARE EQUIPMENT SERVICES PTY LTD | CSS-C SHIELD SPRAY   | 1         | 482.15     |           |
| EFT44136              | 05/07/2022 | ADVANCED TRAFFIC MANAGEMENT (WA) PTY LTD    | 3 X TRAFFIC CONTROLLERS WELLINGTON / ROBINSON / FITZGERALD ST  | 1         |            | 958.10    |
| INV 001535123/02/2022 |            | ADVANCED TRAFFIC MANAGEMENT (WA) PTY LTD    | 3 X TRAFFIC CONTROLLERS WELLINGTON / ROBINSON / FITZGERALD ST  | 1         | 958.10     |           |
| EFT44137              | 05/07/2022 | AMPAC DEBT RECOVERY (WA) P/L                | DEBT RECOVERY FOR PERIOD ENDING 17 JUNE 2022   | 1         |            | 166.93    |
| INV 85236             | 23/06/2022 | AMPAC DEBT RECOVERY (WA) P/L                | DEBT RECOVERY FOR PERIOD ENDING 17 JUNE 2022   | 1         | 166.93     |           |
| EFT44138              | 05/07/2022 | ASTRO SYNTHETIC TURF                        | MANUFACTURE HEAVY DUTY RUBBER CRICKET PITCH COVERS<br>2170 X 2370 30MM DEEP<br>2030 X 2370 30MM DEEP           | 1         |            | 1,925.00  |
| INV 000011823/06/2022 |            | ASTRO SYNTHETIC TURF                        | MANUFACTURE HEAVY DUTY RUBBER CRICKET PITCH COVERS<br>2170 X 2370 30MM DEEP<br>2030 X 2370 30MM DEEP           | 1         | 1,925.00   |           |
| EFT44139              | 05/07/2022 | AUSTRALIAN TAXATION OFFICE - PAYG           | PAYG FOR PAY WEEK ENDING 21/06/2022  | 1         |            | 61,063.20 |
| INV PAYG 221/06/2022  |            | AUSTRALIAN TAXATION OFFICE - PAYG           | PAYG FOR PAY WEEK ENDING 21/06/2022  | 1         | 61,063.20  |           |
| EFT44140              | 05/07/2022 | AVON VALLEY ENVIRONMENTAL SOCIETY           | 2X RIVER WALK TOURS 16 JUNE 2022   | 1         |            | 200.00    |
| INV 24                | 22/06/2022 | AVON VALLEY ENVIRONMENTAL SOCIETY           | 2X RIVER WALK TOURS 16 JUNE 2022   | 1         | 200.00     |           |
| EFT44141              | 05/07/2022 | BLACKWELL PLUMBING & GAS PTY LTD            | CLACKLINE FIRE SHED. INSTALL WATER FILTRATION FROM RAINWATER TANK.   | 1         |            | 677.20    |
| INV INV-26321/06/2022 |            | BLACKWELL PLUMBING & GAS PTY LTD            | REPAIR TO URINAL IN COURTS (ONLY ONE SIDE WORKING)   | 1         | 173.40     |           |
| INV INV-26328/06/2022 |            | BLACKWELL PLUMBING & GAS PTY LTD            | SHOWER 4 IN CHANGEROOMS (COURTS) LEAKING<br>CLACKLINE FIRE SHED. INSTALL WATER FILTRATION FROM RAINWATER TANK. | 1         | 503.80     |           |

Ordinary Council Meeting Agenda  
17 August 2022



Date: 01/08/2022  
Time: 9:17:37AM

Shire of Northam

USER: Louise Harris  
PAGE: 9 13

| Cheque /EFT No        | Date       | Name                           | Invoice Description   | Bank Code | INV Amount | Amount   |
|-----------------------|------------|--------------------------------|---|-----------|------------|----------|
| EFT44142              | 05/07/2022 | BOC LIMITED                    | 11 X 400C OXYGEN MEDICAL C SIZE* RENTAL FEE<br>29.05.2022 TO 27.06.2022 | 1         |            | 68.90    |
| INV 403157628/06/2022 |            | BOC LIMITED                    | 11 X 400C OXYGEN MEDICAL C SIZE* RENTAL FEE<br>29.05.2022 TO 27.06.2022 | 1         | 68.90      |          |
| EFT44143              | 05/07/2022 | BUNNINGS BUILDING SUPPLIES P/L | GIFTS FOR CITIZENSHIP CEREMONY ON 24/06/2022                            | 1         |            | 222.04   |
| INV 2182/0022/06/2022 |            | BUNNINGS BUILDING SUPPLIES P/L | CRAFTRIGHT 2 PIECE CHISEL SET AND PLASTIC TUBING                        | 1         | 29.15      |          |
| INV 2182/0023/06/2022 |            | BUNNINGS BUILDING SUPPLIES P/L | YATES ROSE SHIELD 50L / RICHGRO ANT KILLER 3L                           | 1         | 53.35      |          |
| INV 2182/0023/06/2022 |            | BUNNINGS BUILDING SUPPLIES P/L | BLUELINE FITTINGS AND POLY FITTINGS FOR<br>WUNDOWIE RV PARK             | 1         | 48.50      |          |
| INV 2182/0024/06/2022 |            | BUNNINGS BUILDING SUPPLIES P/L | GIFTS FOR CITIZENSHIP CEREMONY ON 24/06/2022                            | 1         | 91.04      |          |
| EFT44144              | 05/07/2022 | CADD'S FASHIONS                | JBS SOFT SHELL JACKET BLACK SIZE 14                                     | 1         |            | 169.70   |
| INV 22-000016/06/2022 |            | CADD'S FASHIONS                | JBS SOFT SHELL JACKET BLACK SIZE 14                                     | 1         | 169.70     |          |
| EFT44145              | 05/07/2022 | CLOUD COLLECTIONS PTY LTD      | DEBT COLLECTION FOR MAY 2022  | 1         |            | 2,036.68 |
| INV 3109              | 01/06/2022 | CLOUD COLLECTIONS PTY LTD      | DEBT COLLECTION FOR MAY 2022  | 1         | 2,036.68   |          |
| EFT44146              | 05/07/2022 | COUNTRYWIDE GROUP              | EDGER BLADES  | 1         |            | 94.60    |
| INV ACC00127/06/2022  |            | COUNTRYWIDE GROUP              | 8X CHAINSAW FILES   | 1         | 44.00      |          |
| INV ACC00128/06/2022  |            | COUNTRYWIDE GROUP              | EDGER BLADES  | 1         | 50.60      |          |
| EFT44147              | 05/07/2022 | DAIMLER TRUCKS PERTH           | PN1805 - 980U/QMX005028 TANK FILLER CAP FOR<br>ADBLUE                   | 1         |            | 94.59    |
| INV KA980007/04/2022  |            | DAIMLER TRUCKS PERTH           | PN1805 - 980U/QMX005028 TANK FILLER CAP FOR<br>ADBLUE                   | 1         | 94.59      |          |
| EFT44148              | 05/07/2022 | DAMIAN BARNETT                 | REIMBURSEMENT FOR PURCHASE OF 30MM SOCKET                               | 1         |            | 12.99    |
| INV 100029821/06/2022 |            | DAMIAN BARNETT                 | REIMBURSEMENT FOR PURCHASE OF 30MM SOCKET                               | 1         | 12.99      |          |
| EFT44149              | 05/07/2022 | DCM CARPENTRY & MAINTENANCE    | REPAIR SOLAR LEAKS FOR NORTHAM POOL - STADIUM<br>ROOF                   | 1         |            | 2,321.00 |
| INV 1399              | 21/06/2022 | DCM CARPENTRY & MAINTENANCE    | RESCREW WOOD AROUND ALL THE WOODEN SEATING<br>AROUND POOL DECK          | 1         | 880.00     |          |

Ordinary Council Meeting Agenda  
17 August 2022



Date: 01/08/2022  
Time: 9:17:37AM

Shire of Northam

USER: Louise Harris  
PAGE: 10 10

| Cheque /EFT No | Date       | Name  | Invoice Description   | Bank Code | INV Amount | Amount   |
|----------------|------------|---|---|-----------|------------|----------|
| INV 1406       | 26/06/2022 | DCM CARPENTRY & MAINTENANCE                   | REPAIR SOLAR LEAKS FOR NORTHAM POOL - STADIUM ROOF  | 1         | 1,441.00   |          |
| EFT44150       | 05/07/2022 | DONALD GEORGE MOORE                           | RATES CREDIT REFUND FOR ASSESSMENT A12426   | 1         |            | 696.88   |
| INV A12426     | 30/06/2022 | DONALD GEORGE MOORE                           | RATES CREDIT REFUND FOR ASSESSMENT A12426   |           | 696.88     |          |
| EFT44151       | 05/07/2022 | DRACO AIR PTY LTD                             | REPAIRS TO KILLARA KITCHEN COMMERCIAL FRIDGE  | 1         |            | 1,647.98 |
| INV 14417      | 21/02/2022 | DRACO AIR PTY LTD                             | BAKERS HILL PAVILION. REPAIR AIRCONDITIONER TO FROM ROOM.   | 1         | 242.00     |          |
| INV 14662      | 01/06/2022 | DRACO AIR PTY LTD                             | REPAIRS TO KILLARA KITCHEN COMMERCIAL FRIDGE  | 1         | 1,163.98   |          |
| INV 14711      | 28/06/2022 | DRACO AIR PTY LTD                             | REC CENTRE. REPAIR AIRCON NOT WORKING.  | 1         | 242.00     |          |
| EFT44152       | 05/07/2022 | E FIRE & SAFETY                               | MONTHLY ROUTINE MAINTENANCE CHARGES FOR THE TESTING OF THE FIRE DETECTION SYSTEM AT KILLARA - JUNE 2022                   | 1         |            | 677.05   |
| INV 566330     | 28/06/2022 | E FIRE & SAFETY                               | MONTHLY ROUTINE MAINTENANCE CHARGES FOR THE TESTING OF THE FIRE DETECTION SYSTEM AT NORTHAM RECREATION CENTRE - JUNE 2022 | 1         | 254.65     |          |
| INV 566333     | 28/06/2022 | E FIRE & SAFETY                               | MONTHLY ROUTINE MAINTENANCE CHARGES FOR THE TESTING OF THE FIRE DETECTION SYSTEM AT KILLARA - JUNE 2022                   | 1         | 422.40     |          |
| EFT44153       | 05/07/2022 | EVAN DAVID WESLEY                             | RATES CREDIT REFUND FOR ASSESSMENT A1849  | 1         |            | 763.50   |
| INV A1849      | 30/06/2022 | EVAN DAVID WESLEY                             | RATES CREDIT REFUND FOR ASSESSMENT A1849  |           | 763.50     |          |
| EFT44154       | 05/07/2022 | HERRON TODD WHITE (WESTERN AUSTRALIA) PTY LTD | VALUATION FOR AIRPORT HANGAR SITES  | 1         |            | 4,180.00 |
| INV JB292632   | 7/04/2022  | HERRON TODD WHITE (WESTERN AUSTRALIA) PTY LTD | VALUATION FOR AIRPORT HANGAR SITES  | 1         | 4,180.00   |          |
| EFT44155       | 05/07/2022 | JLO DESIGNS                                   | DESIGN APRIL SCHOOL HOLIDAY FLIER 2022  | 1         |            | 65.00    |
| INV 470        | 29/03/2022 | JLO DESIGNS                                   | DESIGN APRIL SCHOOL HOLIDAY FLIER 2022  | 1         | 65.00      |          |
| EFT44156       | 05/07/2022 | KLEENWEST DISTRIBUTORS                        | TRIGGER SPRAY BOTTLES/ GLOVES/ WIPES/ LABELS  | 1         |            | 255.15   |
| INV 000700022  | 06/2022    | KLEENWEST DISTRIBUTORS                        | TRIGGER SPRAY BOTTLES/ GLOVES/ WIPES/ LABELS  | 1         | 255.15     |          |

Date: 01/08/2022  
Time: 9:17:37AM

Shire of Northam

USER: Louise Harris  
PAGE: 11 13

| Cheque /EFT No        | Date       | Name                     | Invoice Description   | Bank Code | INV Amount | Amount    |
|-----------------------|------------|--------------------------|---|-----------|------------|-----------|
| EFT44157              | 05/07/2022 | LANDGATE                 | RURAL UV GENERAL REVALUATION 2021/2022  | 1         |            | 15,283.58 |
| INV 374581            | 16/05/2022 | LANDGATE                 | RURAL UV GENERAL REVALUATION 2021/2022  | 1         | 14,511.00  |           |
| INV 374716            | 20/05/2022 | LANDGATE                 | CONSOLIDATED MINING TENEMENT ROLL   | 1         | 494.30     |           |
| INV 374814            | 25/05/2022 | LANDGATE                 | GROSS RENTAL VALUATIONS CHARGEABLE<br>SCHEDULE: G2022/06<br>DATE: 16/04/2022 TO 13/05/2022    | 1         | 150.04     |           |
| INV 374786            | 25/05/2022 | LANDGATE                 | RURAL UV'S CHARGEABLE<br>SCHEDULE: R2022/4<br>DATE: 02/04/2022 TO 13/05/2022                  | 1         | 86.94      |           |
| INV 374898            | 27/05/2022 | LANDGATE                 | MINING TENEMENTS CHARGEABLE<br>SCHEDULE: M2022/3<br>DATE: 08/04/2022 TO 04/05/2022            | 1         | 41.30      |           |
| EFT44158              | 05/07/2022 | LAURA ANNE-MAREE RUSS    | RATES CREDIT REFUND FOR ASSESSMENT A10866   | 1         |            | 98.88     |
| INV A10866            | 30/06/2022 | LAURA ANNE-MAREE RUSS    | RATES CREDIT REFUND FOR ASSESSMENT A10866   |           | 98.88      |           |
| EFT44159              | 05/07/2022 | LEONIE JUNE WHISSON      | RATES CREDIT REFUND FOR ASSESSMENT A15759   | 1         |            | 122.00    |
| INV A15759            | 30/06/2022 | LEONIE JUNE WHISSON      | RATES CREDIT REFUND FOR ASSESSMENT A15759   |           | 122.00     |           |
| EFT44160              | 05/07/2022 | LGIS - RISK MANAGEMENT   | REGIONAL RISK COORDINATOR FEE 2021-2022 2ND INSTALLMENT                                       | 1         |            | 8,088.85  |
| INV 156-C2221/06/2022 |            | LGIS - RISK MANAGEMENT   | REGIONAL RISK COORDINATOR FEE 2021-2022 2ND INSTALLMENT                                       | 1         | 8,088.85   |           |
| EFT44161              | 05/07/2022 | MCDOWALL AFFLECK PTY LTD | CIVIL AND DUMP POINT DETAILED DESIGN AND DOCUMENTATION OF RV OLD POOL SITE AS PER QUOTE 18235 | 1         |            | 7,315.00  |
| INV 612556            | 22/06/2022 | MCDOWALL AFFLECK PTY LTD | CIVIL AND DUMP POINT DETAILED DESIGN AND DOCUMENTATION OF RV OLD POOL SITE AS PER QUOTE 18235 | 1         | 7,315.00   |           |
| EFT44162              | 05/07/2022 | MICHAEL THOMAS MILLS     | RATES CREDIT REFUND FOR ASSESSMENT A1922  | 1         |            | 643.58    |
| INV A1922             | 30/06/2022 | MICHAEL THOMAS MILLS     | RATES CREDIT REFUND FOR ASSESSMENT A1922  |           | 643.58     |           |

Ordinary Council Meeting Agenda  
17 August 2022



Date: 01/08/2022  
Time: 9:17:37AM

Shire of Northam

USER: Louise Harris  
PAGE: 12 10

| Cheque /EFT No        | Date       | Name  | Invoice Description  | Bank Code | INV Amount | Amount   |
|-----------------------|------------|---|--|-----------|------------|----------|
| EFT44163              | 05/07/2022 | MINT CIVIL PTY LTD T/AS IMMACU SWEEP                      | C.201819-12 STREET SWEEPING & GULLY EDUCTION SERVICES (CLEANING TOWN ROADS) / FOOTPATH & VERGE SWEEPING OF CBD FROM 20/6/2022 - 26/6/2022            | 1         |            | 7,801.20 |
| INV N3016             | 27/06/2022 | MINT CIVIL PTY LTD T/AS IMMACU SWEEP                      | C.201819-12 STREET SWEEPING & GULLY EDUCTION SERVICES (CLEANING TOWN ROADS) / FOOTPATH & VERGE SWEEPING OF CBD FROM 20/6/2022 - 26/6/2022            | 1         | 3,900.60   |          |
| INV N3015             | 27/06/2022 | MINT CIVIL PTY LTD T/AS IMMACU SWEEP                      | C.201819-12 STREET SWEEPING & GULLY EDUCTION SERVICES (CLEANING TOWN ROADS) / C.201819-12 FOOTPATH & VERGE SWEEPING OF CBD - 13/06/2022 - 19/06/2022 | 1         | 3,900.60   |          |
| EFT44164              | 05/07/2022 | MORRIS PEST AND WEED CONTROL                              | BAKERS HILL FIRE SHED. NEW BUILDING - REPLACE RODENT BAITTS AND EXTERNAL SPRAY   | 1         |            | 1,431.75 |
| INV INV-21328/06/2022 |            | MORRIS PEST AND WEED CONTROL                              | REC CENTRE. CHECK RODENT STATIONS AND SEE IF MORE ARE REQUIRED IN KITCHEN AREA AND DAYCARE.  | 1         | 321.75     |          |
| INV INV-21328/06/2022 |            | MORRIS PEST AND WEED CONTROL                              | BAKERS HILL FIRE SHED. NEW BUILDING - REPLACE RODENT BAITTS AND EXTERNAL SPRAY   | 1         | 1,110.00   |          |
| EFT44165              | 05/07/2022 | NORTHAM AUTOS PTY LTD T/AS NORTHAM MAZDA & NORTHAM HOLDEN | N10721 - PN1901 - VIN-MMU148MK0LH607023 - 90,000KM SERVICE REQUIRED  | 1         |            | 783.70   |
| INV 137773            | 17/06/2022 | NORTHAM AUTOS PTY LTD T/AS NORTHAM MAZDA & NORTHAM HOLDEN | N10721 - PN1901 - VIN-MMU148MK0LH607023 - 90,000KM SERVICE REQUIRED  | 1         | 783.70     |          |
| EFT44166              | 05/07/2022 | NORTHAM COMMUNITY MEN'S SHED                              | REPAIR OF BENCHES FROM THE CEMETERY  | 1         |            | 198.00   |
| INV 23                | 28/06/2022 | NORTHAM COMMUNITY MEN'S SHED                              | REPAIR OF BENCHES FROM THE CEMETERY  | 1         | 198.00     |          |
| EFT44167              | 05/07/2022 | NORTHAM DISTRICTS GLASS PTY LTD                           | TOWN AND LESSER HALL. REPLACE 3 X BROKEN WINDOWS.  | 1         |            | 599.00   |
| INV INV-17024/02/2022 |            | NORTHAM DISTRICTS GLASS PTY LTD                           | TOWN AND LESSER HALL. REPLACE 3 X BROKEN WINDOWS.  | 1         | 599.00     |          |
| EFT44168              | 05/07/2022 | NORTHAM FEED & HIRE                                       | SWAN FOOD & OTHER MISCELLANEOUS ITEMS TILL 30/06/2022  | 1         |            | 105.50   |
| INV 000042920/06/2022 |            | NORTHAM FEED & HIRE                                       | SWAN FOOD & OTHER MISCELLANEOUS ITEMS TILL 30/06/2022  | 1         | 83.50      |          |
| INV 000042928/06/2022 |            | NORTHAM FEED & HIRE                                       | SWAN FOOD & OTHER MISCELLANEOUS ITEMS TILL 30/06/2022  | 1         | 22.00      |          |
| EFT44169              | 05/07/2022 | NORTHAM TOWING SERVICE                                    | TOWING OF CRASHED TOYOTA AURION - 1GKL 139   | 1         |            | 261.25   |

Ordinary Council Meeting Agenda  
17 August 2022



Date: 01/08/2022  
Time: 9:17:37AM

Shire of Northam

USER: Louise Harris  
PAGE: 13 13

| Cheque /EFT No         | Date       | Name  | Invoice Description  | Bank Code | INV Amount | Amount     |
|------------------------|------------|---|--|-----------|------------|------------|
| INV 211525             | 17/06/2022 | NORTHAM TOWING SERVICE                                | TOWING OF CRASHED TOYOTA AURION - 1GKL 139   | 1         | 261.25     |            |
| EFT44170               | 05/07/2022 | OASIS OUTDOOR STRUCTURES                              | C.202122-08 - 2021-22 FOOTPATH PROGRAM - BERNARD PARK / EAST ST / GORDON ST / MUDALLA RD / PERINA PATH | 1         |            | 255,057.00 |
| INV INV -06502/03/2022 |            | OASIS OUTDOOR STRUCTURES                              | KERB/CROSSOVER WORKS FOR 17 LYON STREET AS PER QUOTE #QU0758   | 1         | 6,402.00   |            |
| INV INV -06620/06/2022 |            | OASIS OUTDOOR STRUCTURES                              | C.202122-08 - 2021-22 FOOTPATH PROGRAM - BERNARD PARK / EAST ST / GORDON ST / MUDALLA RD / PERINA PATH | 1         | 237,633.00 |            |
| INV INV -06620/06/2022 |            | OASIS OUTDOOR STRUCTURES                              | C.202122-08 - VO 1 - EXTRA COSTING FOR RED COLOUR CONCRETE PATH FOR GORDON STREET AS PER QUOTE QU0771  | 1         | 1,914.00   |            |
| INV INV -06620/06/2022 |            | OASIS OUTDOOR STRUCTURES                              | TREAT ACTIVE TERMITES ON BRIDGE 0608   | 1         | 8,624.00   |            |
| INV INV -06620/06/2022 |            | OASIS OUTDOOR STRUCTURES                              | SUPPLY AND INSTALL PRAM RAMP ON COX STREET NORTHAM   | 1         | 484.00     |            |
| EFT44171               | 05/07/2022 | PERTH SAFETY PRODUCTS PTY LTD - YUNGATHA PTY LTD T/AS | NO PARKING SIGNAGE / KURINGAL RD SIGN  | 1         |            | 138.60     |
| INV 0001118            | 17/02/2022 | PERTH SAFETY PRODUCTS PTY LTD - YUNGATHA PTY LTD T/AS | NO PARKING SIGNAGE / KURINGAL RD SIGN  | 1         | 138.60     |            |
| EFT44172               | 05/07/2022 | POWERCARE   | INSTALLATION OF 5X SOLAR LIGHTS AS PER QUOTE #5852   | 1         |            | 2,667.50   |
| INV PC5852             | 16/06/2022 | POWERCARE   | INSTALLATION OF 5X SOLAR LIGHTS AS PER QUOTE #5852   | 1         | 2,667.50   |            |
| EFT44173               | 05/07/2022 | PRESTIGE ALARMS                                       | ADMIN BUILDING. QUARTERLY SECURITY ALARM MONITORING. 01/06/2022 - 31/08/2022                           | 1         |            | 172.00     |
| INV 000215009          | 05/05/2022 | PRESTIGE ALARMS                                       | ADMIN BUILDING. QUARTERLY SECURITY ALARM MONITORING. 01/06/2022 - 31/08/2022                           | 1         | 172.00     |            |
| EFT44174               | 05/07/2022 | QUIN'S GOURMET BUTCHERS                               | STANDING ORDER FOR MEAT DELIVERED TO KILLARA YEAR 21/22 - DELIVERED 28/6/2022                          | 1         |            | 127.66     |
| INV 000005828          | 06/06/2022 | QUIN'S GOURMET BUTCHERS                               | STANDING ORDER FOR MEAT DELIVERED TO KILLARA YEAR 21/22 - DELIVERED 28/6/2022                          | 1         | 127.66     |            |
| EFT44175               | 05/07/2022 | RED DOT STORES  | GIFT BAGS FOR CITIZENSHIP CEREMONY GIFTS ON 24/06/2022   | 1         |            | 16.00      |

Date: 01/08/2022  
Time: 9:17:37AM

Shire of Northam

USER: Louise Harris  
PAGE: 14 10

| Cheque /EFT No        | Date       | Name  | Invoice Description   | Bank Code | INV Amount | Amount   |
|-----------------------|------------|---|---|-----------|------------|----------|
| INV 416927224/06/2022 |            | RED DOT STORES                                  | GIFT BAGS FOR CITIZENSHIP CEREMONY GIFTS ON 24/06/2022  | 1         | 16.00      |          |
| EFT44176              | 05/07/2022 | SHARRON THERESE MILLER                          | RATES CREDIT REFUND FOR ASSESSMENT A12419   | 1         |            | 763.50   |
| INV A12419            | 30/06/2022 | SHARRON THERESE MILLER                          | RATES CREDIT REFUND FOR ASSESSMENT A12419   |           | 763.50     |          |
| EFT44177              | 05/07/2022 | SHRED-X PTY LTD                                 | EMPTYING OF ADMIN SHREDDER BIN  | 1         |            | 77.69    |
| INV 018204731/05/2022 |            | SHRED-X PTY LTD                                 | EMPTYING OF ADMIN SHREDDER BIN  | 1         | 77.69      |          |
| EFT44178              | 05/07/2022 | STALLION BUILDING CO PTY LTD T/A STALLION HOMES | VO-2 -C.202021-19 - CUTTING BACK 200MM & BACKFILL FOR SECOND TREE HOLE  | 1         |            | 2,615.73 |
| INV 2054              | 23/06/2022 | STALLION BUILDING CO PTY LTD T/A STALLION HOMES | VO-2 -C.202021-19 - CUTTING BACK 200MM & BACKFILL FOR SECOND TREE HOLE  | 1         | 2,615.73   |          |
| EFT44179              | 05/07/2022 | STEWART & HEATON CLOTHING CO.PTY LTD            | ANNUAL DFES APPROVED PPC FOR BFB VOLUNTEERS   | 1         |            | 412.63   |
| INV SIN-35617/06/2022 |            | STEWART & HEATON CLOTHING CO.PTY LTD            | ANNUAL DFES APPROVED PPC FOR BFB VOLUNTEERS   | 1         | 412.63     |          |
| EFT44180              | 05/07/2022 | SUSAN MAE CONNELL                               | REIMBURSEMENT OF CANCELLED "KANGAROO IN THE SKY" WORKSHOP FEE   | 1         |            | 10.00    |
| INV 011804            | 01/04/2022 | SUSAN MAE CONNELL                               | REIMBURSEMENT OF CANCELLED "KANGAROO IN THE SKY" WORKSHOP FEE   | 1         | 10.00      |          |
| EFT44181              | 05/07/2022 | THEA COMMINS                                    | BOOKMARKS   | 1         |            | 100.10   |
| INV 000278915/02/2022 |            | THEA COMMINS                                    | BOOKMARKS   | 1         | 100.10     |          |
| EFT44182              | 05/07/2022 | THIS IS CREATIVE PTY LTD                        | 2022 NCC SEMINARS- VOLUMES ONE & TWO - GORDON TESTER, 25 AUGUST, PERTH CONVENTION CENTRE 9AM-1PM                                | 1         |            | 130.00   |
| INV 119694322/04/2022 |            | THIS IS CREATIVE PTY LTD                        | 2022 NCC SEMINARS- VOLUMES ONE & TWO - GORDON TESTER, 25 AUGUST, PERTH CONVENTION CENTRE 9AM-1PM                                | 1         | 130.00     |          |
| EFT44183              | 05/07/2022 | UNITED SCANNING SERVICES PTY LTD                | GROUND PENETRATION RADAR SCANNING AND CABLE LOCATING WITHIN THE ROAD RESERVE SECTION OF MITCHELL AVE NORTHAM SLK2.90 TO SLK3.40 | 1         |            | 1,573.00 |



Ordinary Council Meeting Agenda  
17 August 2022



Date: 01/08/2022  
Time: 9:17:37AM

Shire of Northam

USER: Louise Harris  
PAGE: 15 13

| Cheque /EFT No        | Date       | Name   | Invoice Description  | Bank Code | INV Amount | Amount   |
|-----------------------|------------|--|--|-----------|------------|----------|
| INV 220621_21/06/2022 |            | UNITED SCANNING SERVICES PTY LTD             | GROUND PENETRATION RADAR SCANNING AND CABLE LOCATING WITHIN THE ROAD RESERVE SECTION OF MITCHELL AVE NORTHAM SLK2.90 TO SLK3.40  | 1         | 1,573.00   |          |
| EFT44184              | 05/07/2022 | WA CONTRACT RANGER SERVICES                  | MANAGMENT OF SHIRE OF NORTHAM DOG IMPOUND FACILITY AS PER C.201920-09 - 13/6/22 TO 26/6/22   | 1         |            | 1,320.00 |
| INV 000040427/06/2022 |            | WA CONTRACT RANGER SERVICES                  | MANAGMENT OF SHIRE OF NORTHAM DOG IMPOUND FACILITY AS PER C.201920-09 - 13/6/22 TO 26/6/22   | 1         | 1,320.00   |          |
| EFT44185              | 05/07/2022 | WESTERN IRRIGATION PTY LTD                   | CONDUCT ONSITE REVIEW EACH POS AND PAW CONTAINING IRRIGATION USING RECYCLED EFFLUENT WATER.<br>CONDUCT ONSITE REVIEW OF RECYCLED EFFLUENT SOURCE INFRASTRUCTURE.<br>CONDUCT REVIEW OF EXISTING OPERATIONAL GUIDELINES.<br>PROVIDE A REPORT CONTAINING THE FINDINGS OF THE ABOVE WORKS WITH INDICATIVE COSTING TO EITHER UPGRADE, OR RE-CONSTRUCT IN ACCORDANCE WITH ALL RELEVANT REGULATORY REQUIREMENTS | 1         |            | 9,570.00 |
| INV P48555            | 01/01/2022 | WESTERN IRRIGATION PTY LTD                   | CONDUCT ONSITE REVIEW EACH POS AND PAW CONTAINING IRRIGATION USING RECYCLED EFFLUENT WATER.<br>CONDUCT ONSITE REVIEW OF RECYCLED EFFLUENT SOURCE INFRASTRUCTURE.<br>CONDUCT REVIEW OF EXISTING OPERATIONAL GUIDELINES.<br>PROVIDE A REPORT CONTAINING THE FINDINGS OF THE ABOVE WORKS WITH INDICATIVE COSTING TO EITHER UPGRADE, OR RE-CONSTRUCT IN ACCORDANCE WITH ALL RELEVANT REGULATORY REQUIREMENTS | 1         | 9,570.00   |          |
| EFT44186              | 05/07/2022 | WESTWIDE AUTO ELECTRICS AND AIR CONDITIONING | PN1314 -VOLVO GRADER REPAIR HEADLIGHTS   | 1         |            | 510.00   |
| INV INV-13522/06/2022 |            | WESTWIDE AUTO ELECTRICS AND AIR CONDITIONING | PN1314 -VOLVO GRADER REPAIR HEADLIGHTS   | 1         | 510.00     |          |

Date: 01/08/2022  
Time: 9:17:37AM

Shire of Northam

USER: Louise Harris  
PAGE: 16 10

| Cheque /EFT No        | Date       | Name                                  | Invoice Description  | Bank Code | INV Amount | Amount   |
|-----------------------|------------|---------------------------------------|--|-----------|------------|----------|
| EFT44187              | 05/07/2022 | WHEATBELT NATURAL RESOURCE MANAGEMENT | MAINTENANCE OF NORTHAM CEMETERY AS PER C.201920-17. JULY, AUGUST, SEPTEMBER & OCTOBER 2021. 4 HRS A DAY / 3 DAYS A WEEK WITH 3 CREW MEMBERS. - FORTNIGHT ENDING 17/06/2022 | 1         |            | 7,706.16 |
| INV 003013407/06/2022 |            | WHEATBELT NATURAL RESOURCE MANAGEMENT | MAINTENANCE OF NORTHAM CEMETERY AS PER C.201920-17. JULY, AUGUST, SEPTEMBER & OCTOBER 2021. 4 HRS A DAY / 3 DAYS A WEEK WITH 3 CREW MEMBERS. - FORTNIGHT ENDING 03/06/2022 | 1         | 3,669.60   |          |
| INV 003013420/06/2022 |            | WHEATBELT NATURAL RESOURCE MANAGEMENT | MAINTENANCE OF NORTHAM CEMETERY AS PER C.201920-17. JULY, AUGUST, SEPTEMBER & OCTOBER 2021. 4 HRS A DAY / 3 DAYS A WEEK WITH 3 CREW MEMBERS. - FORTNIGHT ENDING 17/06/2022 | 1         | 4,036.56   |          |
| EFT44199              | 07/07/2022 | ATTILA JOHN MENC SHELYI               | COUNCILLOR PAYMENTS FOR JUNE 2022  | 1         |            | 2,154.37 |
| INV JUNE 2 30/06/2022 |            | ATTILA JOHN MENC SHELYI               | COUNCILLOR PAYMENTS FOR JUNE 2022  | 1         | 2,071.49   |          |
| INV JUNE 2 30/06/2022 |            | ATTILA JOHN MENC SHELYI               | REVERSAL - INCORRECT PAYMENT   | 1         | -2,071.49  |          |
| INV JUNE 2 30/06/2022 |            | ATTILA JOHN MENC SHELYI               | COUNCILLOR PAYMENTS FOR JUNE 2022  | 1         | 2,154.37   |          |
| EFT44200              | 07/07/2022 | BROOKLANDS SUPER PTY LTD              | COUNCILLOR PAYMENTS FOR JUNE 2022  | 1         |            | 1,100.00 |
| INV JUNE 2 30/06/2022 |            | BROOKLANDS SUPER PTY LTD              | COUNCILLOR PAYMENTS FOR JUNE 2022  | 1         | 1,100.00   |          |
| INV JUNE 2 30/06/2022 |            | BROOKLANDS SUPER PTY LTD              | REVERSAL - INCORRECT PAYMENT   | 1         | -1,100.00  |          |
| INV JUNE 2 30/06/2022 |            | BROOKLANDS SUPER PTY LTD              | COUNCILLOR PAYMENTS FOR JUNE 2022  | 1         | 1,100.00   |          |
| EFT44201              | 07/07/2022 | CHRISTOPHER RICHARD ANTONIO           | COUNCILLOR PAYMENTS FOR JUNE 2022  | 1         |            | 5,930.65 |
| INV JUNE 2 30/06/2022 |            | CHRISTOPHER RICHARD ANTONIO           | COUNCILLOR PAYMENTS FOR JUNE 2022  | 1         | 5,483.36   |          |
| INV JUNE 2 30/06/2022 |            | CHRISTOPHER RICHARD ANTONIO           | REVERSAL - INCORRECT PAYMENT   | 1         | -5,483.36  |          |
| INV JUNE 2 30/06/2022 |            | CHRISTOPHER RICHARD ANTONIO           | COUNCILLOR PAYMENTS FOR JUNE 2022  | 1         | 5,930.65   |          |
| EFT44202              | 07/07/2022 | DAVID JAMES GALLOWAY                  | COUNCILLOR PAYMENTS FOR JUNE 2022  | 1         |            | 2,009.33 |
| INV JUNE 2 30/06/2022 |            | DAVID JAMES GALLOWAY                  | COUNCILLOR PAYMENTS FOR JUNE 2022  | 1         | 1,905.73   |          |
| INV JUNE 2 30/06/2022 |            | DAVID JAMES GALLOWAY                  | REVERSAL - INCORRECT PAYMENT   | 1         | -1,905.73  |          |

Ordinary Council Meeting Agenda  
17 August 2022



Date: 01/08/2022  
Time: 9:17:37AM

Shire of Northam

USER: Louise Harris  
PAGE: 17 13

| Cheque /EFT No        | Date       | Name                            | Invoice Description               | Bank Code | INV Amount | Amount   |
|-----------------------|------------|---------------------------------|-----------------------------------|-----------|------------|----------|
| INV JUNE 2 30/06/2022 |            | DAVID JAMES GALLOWAY            | COUNCILLOR PAYMENTS FOR JUNE 2022 | 1         | 2,009.33   |          |
| EFT44203              | 07/07/2022 | DESMOND ARNOLD HUGHES           | COUNCILLOR PAYMENTS FOR JUNE 2022 | 1         |            | 1,982.35 |
| INV JUNE 2 30/06/2022 |            | DESMOND ARNOLD HUGHES           | COUNCILLOR PAYMENTS FOR JUNE 2022 | 1         | 1,905.73   |          |
| INV JUNE 2 30/06/2022 |            | DESMOND ARNOLD HUGHES           | REVERSAL - INCORRECT PAYMENT      | 1         | -1,905.73  |          |
| INV JUNE 2 30/06/2022 |            | DESMOND ARNOLD HUGHES           | COUNCILLOR PAYMENTS FOR JUNE 2022 | 1         | 1,982.35   |          |
| EFT44204              | 07/07/2022 | HAYDEN JOHN APPLETON            | COUNCILLOR PAYMENTS FOR JUNE 2022 | 1         |            | 1,905.73 |
| INV JUNE 2 30/06/2022 |            | HAYDEN JOHN APPLETON            | COUNCILLOR PAYMENTS FOR JUNE 2022 | 1         | 1,905.73   |          |
| INV JUNE 2 30/06/2022 |            | HAYDEN JOHN APPLETON            | REVERSAL - INCORRECT PAYMENT      | 1         | -1,905.73  |          |
| INV JUNE 2 30/06/2022 |            | HAYDEN JOHN APPLETON            | COUNCILLOR PAYMENTS FOR JUNE 2022 | 1         | 1,905.73   |          |
| EFT44205              | 07/07/2022 | JULIE ELLEN GREENFIELD WILLIAMS | COUNCILLOR PAYMENTS FOR JUNE 2022 | 1         |            | 2,065.57 |
| INV JUNE 2 30/06/2022 |            | JULIE ELLEN GREENFIELD WILLIAMS | COUNCILLOR PAYMENTS FOR JUNE 2022 | 1         | 1,905.73   |          |
| INV JUNE 2 30/06/2022 |            | JULIE ELLEN GREENFIELD WILLIAMS | REVERSAL - INCORRECT PAYMENT      | 1         | -1,905.73  |          |
| INV JUNE 2 30/06/2022 |            | JULIE ELLEN GREENFIELD WILLIAMS | COUNCILLOR PAYMENTS FOR JUNE 2022 | 1         | 2,065.57   |          |
| EFT44206              | 07/07/2022 | MARIA IRENE GIRAK               | COUNCILLOR PAYMENTS FOR JUNE 2022 | 1         |            | 1,905.73 |
| INV JUNE 2 30/06/2022 |            | MARIA IRENE GIRAK               | COUNCILLOR PAYMENTS FOR JUNE 2022 | 1         | 1,905.73   |          |
| INV JUNE 2 30/06/2022 |            | MARIA IRENE GIRAK               | REVERSAL - INCORRECT PAYMENT      | 1         | -1,905.73  |          |
| INV JUNE 2 30/06/2022 |            | MARIA IRENE GIRAK               | COUNCILLOR PAYMENTS FOR JUNE 2022 | 1         | 1,905.73   |          |
| EFT44207              | 07/07/2022 | MICHAEL PATRICK RYAN            | COUNCILLOR PAYMENTS FOR JUNE 2022 | 1         |            | 2,843.23 |
| INV JUNE 2 30/06/2022 |            | MICHAEL PATRICK RYAN            | COUNCILLOR PAYMENTS FOR JUNE 2022 | 1         | 2,843.23   |          |
| INV JUNE 2 30/06/2022 |            | MICHAEL PATRICK RYAN            | REVERSAL - INCORRECT PAYMENT      | 1         | -2,843.23  |          |
| INV JUNE 2 30/06/2022 |            | MICHAEL PATRICK RYAN            | COUNCILLOR PAYMENTS FOR JUNE 2022 | 1         | 2,843.23   |          |
| EFT44208              | 07/07/2022 | PAUL THOMAS CURTIS              | COUNCILLOR PAYMENTS FOR JUNE 2022 | 1         |            | 2,185.60 |
| INV JUNE 2 30/06/2022 |            | PAUL THOMAS CURTIS              | COUNCILLOR PAYMENTS FOR JUNE 2022 | 1         | 2,015.99   |          |

Ordinary Council Meeting Agenda  
17 August 2022



Date: 01/08/2022  
Time: 9:17:37AM

Shire of Northam

USER: Louise Harris  
PAGE: 18 10

| Cheque /EFT No | Date       | Name                                     | Invoice Description   | Bank Code | INV Amount | Amount   |
|----------------|------------|--|---|-----------|------------|----------|
| INV JUNE 2     | 30/06/2022 | PAUL THOMAS CURTIS                       | REVERSAL - INCORRECT PAYMENT  | 1         | -2,015.99  |          |
| INV JUNE 2     | 30/06/2022 | PAUL THOMAS CURTIS                       | COUNCILLOR PAYMENTS FOR JUNE 2022   | 1         | 2,185.60   |          |
| EFT44209       | 07/07/2022 | ROBERT WAYNE TINETTI                     | COUNCILLOR PAYMENTS FOR JUNE 2022   | 1         |            | 1,905.73 |
| INV JUNE 2     | 30/06/2022 | ROBERT WAYNE TINETTI                     | COUNCILLOR PAYMENTS FOR JUNE 2022   | 1         | 1,905.73   |          |
| INV JUNE 2     | 30/06/2022 | ROBERT WAYNE TINETTI                     | REVERSAL - INCORRECT PAYMENT  | 1         | -1,905.73  |          |
| INV JUNE 2     | 30/06/2022 | ROBERT WAYNE TINETTI                     | COUNCILLOR PAYMENTS FOR JUNE 2022   | 1         | 1,905.73   |          |
| EFT44210       | 12/07/2022 | AGWEST MACHINERY - GREYMACH PTY LTD T/AS | PN1904 - WUNDOWIE KUBOTA MOWER 400HR SERVICE AND REPAIRS AS PER QUOTE#38204. 01/06/2022 | 1         |            | 1,364.36 |
| INV 328701     | 22/06/2022 | AGWEST MACHINERY - GREYMACH PTY LTD T/AS | PN1904 - WUNDOWIE KUBOTA MOWER 400HR SERVICE AND REPAIRS AS PER QUOTE#38204. 01/06/2022 | 1         | 1,364.36   |          |
| EFT44211       | 12/07/2022 | ANDY'S PLUMBING SERVICE                  | TOWN HALL. UNBLOCK LADIES TOILET AND REPAIR DOOR LOCK TO OTHER.                         | 1         |            | 2,586.65 |
| INV A19332     | 01/07/2022 | ANDY'S PLUMBING SERVICE                  | MEMORIAL HALL. REPAIR LEAKING TOILET IN LADIES.   | 1         | 217.80     |          |
| INV A19335     | 01/07/2022 | ANDY'S PLUMBING SERVICE                  | BERNARD PARK TOILETS. MONTHLY URINAL SERVICING - JUNE 2022                              | 1         | 544.50     |          |
| INV A19331     | 01/07/2022 | ANDY'S PLUMBING SERVICE                  | TOWN HALL. UNBLOCK LADIES TOILET AND REPAIR DOOR LOCK TO OTHER.                         | 1         | 589.05     |          |
| INV A19333     | 01/07/2022 | ANDY'S PLUMBING SERVICE                  | NORTHAM LIBRARY. UNBLOCK TOILETS.   | 1         | 429.00     |          |
| INV A19334     | 01/07/2022 | ANDY'S PLUMBING SERVICE                  | BERNARD PARK TOILETS. MONTHLY URINAL SERVICING - MAY 2022                               | 1         | 385.00     |          |
| INV A19330     | 01/07/2022 | ANDY'S PLUMBING SERVICE                  | YOUTH PARK. REPAIR LEAKING TAP.   | 1         | 214.50     |          |
| INV A19329     | 01/07/2022 | ANDY'S PLUMBING SERVICE                  | BKB. REPAIR DISHWASHER DOOR AND CHECK OPERATION.  | 1         | 206.80     |          |
| EFT44212       | 12/07/2022 | ASHTON STEWART                           | REIMBURSE FOR WORKING WITH CHILDREN CHECK   | 1         |            | 144.60   |
| INV 421425630  | 06/2022    | ASHTON STEWART                           | REIMBURSE FOR WORKING WITH CHILDREN CHECK   | 1         | 87.00      |          |
| INV 640488     | 06/07/2022 | ASHTON STEWART                           | REIMBURSEMENT OF POLICE CLEARANCE ASHTON STEWART (COMMUNITY SERVICES)                   | 1         | 57.60      |          |
| EFT44213       | 12/07/2022 | AUSTRALIA POST                           | AUSTRALIA POST CHARGES - JUNE 2022 - ADMIN / BKB  | 1         |            | 738.41   |

Ordinary Council Meeting Agenda  
17 August 2022



Date: 01/08/2022  
Time: 9:17:37AM

Shire of Northam

USER: Louise Harris  
PAGE: 19 13

| Cheque /EFT No | Date       | Name                                  | Invoice Description   | Bank Code | INV Amount | Amount   |
|----------------|------------|---------------------------------------|---|-----------|------------|----------|
| INV 101166103  | 07/2022    | AUSTRALIA POST                        | AUSTRALIA POST CHARGES - JUNE 2022 - ADMIN / BKB  | 1         | 738.41     |          |
| EFT44214       | 12/07/2022 | AUSTRALIAN SERVICES UNION             | PAYROLL DEDUCTIONS  | 1         |            | 129.50   |
| INV DEDUC05    | 07/2022    | AUSTRALIAN SERVICES UNION             | PAYROLL DEDUCTIONS  |           | 129.50     |          |
| EFT44215       | 12/07/2022 | AUTOPRO NORTHAM                       | REPLACEMENT TOW HITCH PIN FOR PN2011  | 1         |            | 13.87    |
| INV 100237301  | 07/2022    | AUTOPRO NORTHAM                       | REPLACEMENT TOW HITCH PIN FOR PN2011  | 1         | 13.87      |          |
| EFT44216       | 12/07/2022 | AVON VALLEY BAKERY                    | 250 NAIDOC THEMED CUPCAKES-EVENT 07/07/2022   | 1         |            | 450.00   |
| INV INV-09607  | 07/2022    | AVON VALLEY BAKERY                    | 250 NAIDOC THEMED CUPCAKES-EVENT 07/07/2022   | 1         | 450.00     |          |
| EFT44217       | 12/07/2022 | AVON VALLEY PLANT & EQUIPMENT PTY LTD | SIEVE ROCKS AND PLACE AS PER DRAWING TO DISCOURAGE TRAFFIC. NO MOB/DEMOB AS MACHINE ON SITE | 1         |            | 1,980.00 |
| INV IV1085428  | 06/2022    | AVON VALLEY PLANT & EQUIPMENT PTY LTD | SIEVE ROCKS AND PLACE AS PER DRAWING TO DISCOURAGE TRAFFIC. NO MOB/DEMOB AS MACHINE ON SITE | 1         | 1,980.00   |          |
| EFT44218       | 12/07/2022 | BAKERS HILL RURAL SUPPLIES & HARDWARE | BLUELINE 40MM FITTINGS  | 1         |            | 120.00   |
| INV 171524     | 05/07/2022 | BAKERS HILL RURAL SUPPLIES & HARDWARE | BLUELINE 40MM FITTINGS  | 1         | 87.00      |          |
| INV 171555     | 06/07/2022 | BAKERS HILL RURAL SUPPLIES & HARDWARE | REPLACEMENT GAS BOTTLE  | 1         | 33.00      |          |
| EFT44219       | 12/07/2022 | BANDIT TREE EQUIPMENT                 | U BOLT 9/16" X 95MM X200MM / LEAF SPRING FOR 8K AXLE  | 1         |            | 1,465.09 |
| INV 1281W      | 29/06/2022 | BANDIT TREE EQUIPMENT                 | U BOLT 9/16" X 95MM X200MM / LEAF SPRING FOR 8K AXLE  | 1         | 1,465.09   |          |
| EFT44220       | 12/07/2022 | BIG BUBBLE RETAIL                     | CANE FOR WAGAL STREET PARADE PUPPET   | 1         |            | 262.20   |
| INV 14461      | 27/06/2022 | BIG BUBBLE RETAIL                     | CANE FOR WAGAL STREET PARADE PUPPET   | 1         | 262.20     |          |
| EFT44221       | 12/07/2022 | BUILDER'S REGISTRATION BOARD OF WA    | MONTHLY BSL FEES COLLECTED FOR THE BUILDING COMMISSION FOR THE MONTH OF JUNE 2022           | 1         |            | 5,733.71 |
| INV T1080      | 08/07/2022 | BUILDER'S REGISTRATION BOARD OF WA    | MONTHLY BSL FEES COLLECTED FOR THE BUILDING COMMISSION FOR THE MONTH OF JUNE 2022           | 1         | 5,733.71   |          |

Date: 01/08/2022  
Time: 9:17:37AM

Shire of Northam

USER: Louise Harris  
PAGE: 20 10

| Cheque /EFT No        | Date       | Name   | Invoice Description  | Bank Code | INV Amount | Amount |
|-----------------------|------------|--|--|-----------|------------|--------|
| EFT44222              | 12/07/2022 | BUILDING AND CONSTRUCTION INDUSTRY TRAINING FUND | MONTHLY BCITF FEES COLLECTED FOR THE CONSTRUCTION TRAINING FUND FOR THE MONTH OF JUNE 2022                   | 1         |            | 512.89 |
| INV T1079             | 08/07/2022 | BUILDING AND CONSTRUCTION INDUSTRY TRAINING FUND | MONTHLY BCITF FEES COLLECTED FOR THE CONSTRUCTION TRAINING FUND FOR THE MONTH OF JUNE 2022                   | 1         | 512.89     |        |
| EFT44223              | 12/07/2022 | BUNNINGS BUILDING SUPPLIES P/L                   | FIRE EXTINGUISHER  | 1         |            | 85.24  |
| INV 2182/0027/06/2022 |            | BUNNINGS BUILDING SUPPLIES P/L                   | CABLE TIES   | 1         | 20.64      |        |
| INV 2182/0001/07/2022 |            | BUNNINGS BUILDING SUPPLIES P/L                   | FIRE EXTINGUISHER  | 1         | 64.60      |        |
| EFT44224              | 12/07/2022 | CADD'S FASHIONS                                  | SHIRTS / PANTS   | 1         |            | 695.20 |
| INV 22-000009/06/2022 |            | CADD'S FASHIONS                                  | UNIFORMS - LOUISE DYER   | 1         | 140.30     |        |
| INV 22-000030/06/2022 |            | CADD'S FASHIONS                                  | WORKBOOT ALLOWANCE - RUSSELL PUTRINO   | 1         | 170.00     |        |
| INV 22-000006/07/2022 |            | CADD'S FASHIONS                                  | SHIRTS / PANTS   | 1         | 384.90     |        |
| EFT44225              | 12/07/2022 | CHILD SUPPORT AGENCY                             | PAYROLL DEDUCTIONS   | 1         |            | 138.85 |
| INV DEDUC05/07/2022   |            | CHILD SUPPORT AGENCY                             | PAYROLL DEDUCTIONS   |           | 138.85     |        |
| EFT44226              | 12/07/2022 | CONTRAFLOW PTY LTD                               | TRAFFIC MANAGEMENT PLAN AMENDMENT FEE - AVON DESCENT BILYA FESTIVAL 2022                                     | 1         |            | 165.62 |
| INV T18/68718/03/2022 |            | CONTRAFLOW PTY LTD                               | TRAFFIC MANAGEMENT PLAN AMENDMENT FEE - AVON DESCENT BILYA FESTIVAL 2022                                     | 1         | 165.62     |        |
| EFT44227              | 12/07/2022 | COUNTRY COMFORTSTYLE NORTHAM                     | BROOM CUPBOARD   | 1         |            | 384.00 |
| INV 17458 27/06/2022  |            | COUNTRY COMFORTSTYLE NORTHAM                     | BROOM CUPBOARD   | 1         | 384.00     |        |
| EFT44228              | 12/07/2022 | COUNTRY COPIERS NORTHAM                          | 89X62 AVERY LABELS   | 1         |            | 214.55 |
| INV 45113 30/06/2022  |            | COUNTRY COPIERS NORTHAM                          | 89X62 AVERY LABELS   | 1         | 98.00      |        |
| INV 45113 30/06/2022  |            | COUNTRY COPIERS NORTHAM                          | 1 X FINANCIAL YEAR DIARY   | 1         | 35.70      |        |
| INV 45113 30/06/2022  |            | COUNTRY COPIERS NORTHAM                          | FINANCIAL YEAR DIARY 2 DAYS PER PAGE BINDING SPIRALS (VARIETY OF SIZES) PLASTIC COVERS FOR BINDING DOCUMENTS | 1         | 80.85      |        |

Ordinary Council Meeting Agenda  
17 August 2022



Date: 01/08/2022  
Time: 9:17:37AM

Shire of Northam

USER: Louise Harris  
PAGE: 21 13

| Cheque /EFT No         | Date       | Name   | Invoice Description   | Bank Code | INV Amount | Amount    |
|------------------------|------------|--|---|-----------|------------|-----------|
| EFT44229               | 12/07/2022 | DCM CARPENTRY & MAINTENANCE                  | REC CENTRE STADIUM ROOF LEAK  | 1         |            | 3,020.60  |
| INV 1407               | 26/06/2022 | DCM CARPENTRY & MAINTENANCE                  | REPAIR TO TURNSTILE - ADD GARRISEN POLE   | 1         | 459.80     |           |
| INV 1410               | 26/06/2022 | DCM CARPENTRY & MAINTENANCE                  | REC CENTRE STADIUM ROOF LEAK  | 1         | 1,466.30   |           |
| INV 1409               | 26/06/2022 | DCM CARPENTRY & MAINTENANCE                  | FIRST AID ROOM LEAKS (NEW FIRST AID ROOM NEAR MAIN OFFICE)  | 1         | 819.50     |           |
| INV 1412               | 28/06/2022 | DCM CARPENTRY & MAINTENANCE                  | BARBS FOR REPAIRS TO SOLAR PANELS - NORTHAM POOL  | 1         | 275.00     |           |
| EFT44230               | 12/07/2022 | DEBORAH MOODY                                | WTC PERFORMED BY DEBORAH MOODY @ BIL YA KOORT BOODJA CENTRE FOR POLICE MEETING ON THE 20TH OF JUNE 2022 | 1         |            | 300.00    |
| INV 22                 | 20/06/2022 | DEBORAH MOODY                                | WTC PERFORMED BY DEBORAH MOODY @ BIL YA KOORT BOODJA CENTRE FOR POLICE MEETING ON THE 20TH OF JUNE 2022 | 1         | 300.00     |           |
| EFT44231               | 12/07/2022 | DEPARTMENT OF WATER & ENVIRONMENT REGULATION | DWER QUARTERLY LEVY RETURN; APRIL - JUNE 2022   | 1         |            | 12,072.42 |
| INV JJ 0807208/07/2022 |            | DEPARTMENT OF WATER & ENVIRONMENT REGULATION | DWER QUARTERLY LEVY RETURN; APRIL - JUNE 2022   | 1         | 12,072.42  |           |
| EFT44232               | 12/07/2022 | EASIFLEET                                    | PAYROLL DEDUCTIONS  | 1         |            | 1,853.35  |
| INV DEDUC05/07/2022    |            | EASIFLEET                                    | PAYROLL DEDUCTIONS  |           | 1,054.26   |           |
| INV DEDUC05/07/2022    |            | EASIFLEET                                    | PAYROLL DEDUCTIONS  |           | 799.09     |           |
| EFT44233               | 12/07/2022 | GLENN STUART BEVERIDGE                       | POND 3 PERIMETER FENCING REMOVED / POND 3 PERIMETER FENCING REPLACED                                    | 1         |            | 3,850.00  |
| INV 322                | 09/06/2022 | GLENN STUART BEVERIDGE                       | POND 3 PERIMETER FENCING REMOVED / POND 3 PERIMETER FENCING REPLACED                                    | 1         | 3,850.00   |           |
| EFT44234               | 12/07/2022 | JACKSON HARVEY                               | BEAVIS PLACE MURAL - 3 INTERCHANGEABLE ARTWORKS 1.5x2.15M DESIGN FEE                                    | 1         |            | 10,990.00 |
| INV 170620217/06/2022  |            | JACKSON HARVEY                               | BEAVIS PLACE MURAL - 3 INTERCHANGEABLE ARTWORKS 1.5x2.15M DESIGN FEE                                    | 1         | 10,990.00  |           |

Date: 01/08/2022  
Time: 9:17:37AM

Shire of Northam

USER: Louise Harris  
PAGE: 22 10

| Cheque /EFT No | Date       | Name                    | Invoice Description  | Bank Code | INV Amount | Amount    |
|----------------|------------|-------------------------|--|-----------|------------|-----------|
| EFT44235       | 12/07/2022 | JLO DESIGNS             | JULY SCHOOL HOLIDAY POSTER DESIGN 2022   | 1         |            | 65.00     |
| INV 478        | 28/06/2022 | JLO DESIGNS             | JULY SCHOOL HOLIDAY POSTER DESIGN 2022   | 1         | 65.00      |           |
| EFT44236       | 12/07/2022 | JOMAR WA PTY LTD        | PROPPING OF BRIDGE 0610 AS PER MRWA REQUIREMENTS   | 1         |            | 12,265.00 |
| INV IN0269     | 30/06/2022 | JOMAR WA PTY LTD        | PROPPING OF BRIDGE 0610 AS PER MRWA REQUIREMENTS   | 1         | 12,265.00  |           |
| EFT44237       | 12/07/2022 | KIRK GARLETT            | SALE OF ARTWORK (KIRK GARLETT)   | 1         |            | 1,000.00  |
| INV 8          | 27/06/2022 | KIRK GARLETT            | SALE OF ARTWORK (KIRK GARLETT)   | 1         | 1,000.00   |           |
| EFT44238       | 12/07/2022 | KUDZAIMATANGA           | KUDZAIMATANGA RELOCATION EXPENSES - REMOVALIST / STORAGE BOXES / FUEL                                      | 1         |            | 1,641.98  |
| INV AR 010701  | 07/2022    | KUDZAIMATANGA           | REIMBURSEMENT OF POLICE CLEARANCE & MEDICALS (SPIROMETRY & MEDICAL)  | 1         | 376.60     |           |
| INV CY 040704  | 07/2022    | KUDZAIMATANGA           | KUDZAIMATANGA (SENIOR ACCOUNTANT) KUDZAIMATANGA RELOCATION EXPENSES - REMOVALIST / STORAGE BOXES / FUEL    | 1         | 1,265.38   |           |
| EFT44239       | 12/07/2022 | MAJOR MOTORS            | FLOOR MATS FOR ISUZU NPR 65/45-190 CREW TIPPER TRUCK   | 1         |            | 99.28     |
| INV 122527907  | 07/2022    | MAJOR MOTORS            | FLOOR MATS FOR ISUZU NPR 65/45-190 CREW TIPPER TRUCK   | 1         | 99.28      |           |
| EFT44240       | 12/07/2022 | NINTEX PTY LTD          | SOFTWARE - PROCESS MAPPING, RISK & COMPLIANCE MANAGEMENT, IMPROVEMENT & INCIDENT MANAGEMENT                | 1         |            | 31,059.60 |
| INV INV598     | 14/06/2022 | NINTEX PTY LTD          | SOFTWARE - PROCESS MAPPING, RISK & COMPLIANCE MANAGEMENT, IMPROVEMENT & INCIDENT MANAGEMENT                | 1         | 31,059.60  |           |
| EFT44241       | 12/07/2022 | NORTH METROPOLITAN TAFE | AHCMOM213 - OPERATE AND MAINTAIN CHAINSAWS. NORTH METRO TAFE MIDLAND - RILEY BLANKENDAAL / DANICA BRADFORD | 1         |            | 283.40    |



Ordinary Council Meeting Agenda  
17 August 2022



Date: 01/08/2022  
Time: 9:17:37AM

Shire of Northam

USER: Louise Harris  
PAGE: 23 13

| Cheque /EFT No        | Date       | Name                               | Invoice Description   | Bank Code | INV Amount | Amount   |
|-----------------------|------------|------------------------------------|---|-----------|------------|----------|
| INV I00332330/06/2022 |            | NORTH METROPOLITAN TAFE            | DANICA BRADFORD / RILEY BLANKENDAAL - SEMESTER 2 2022   | 1         | 130.00     |          |
| INV I00332930/06/2022 |            | NORTH METROPOLITAN TAFE            | AHCNSY306 - IMPLEMENT A PROPAGATION PLAN<br>AHCPCM301 - IMPLEMENT A PLANT NUTRITION PR<br>AHC SOL303 - IMPLEMENT SOIL IMPROVEMENTS FO<br>AHC MOM213 - OPERATE AND MAINTAIN CHAINSAWS.<br>NORTH METRO TAFE MIDLAND - RILEY BLANKENDAAL / DANICA BRADFORD | 1         | 153.40     |          |
| EFT44242              | 12/07/2022 | NORTHAM CHAMBER OF COMMERCE        | BILYA FESTIVAL FULL PAGE AD- JULY 2022  | 1         |            | 1,061.50 |
| INV 000003628/06/2022 |            | NORTHAM CHAMBER OF COMMERCE        | BILYA FESTIVAL FULL PAGE AD- JULY 2022  | 1         | 440.00     |          |
| INV 000003728/06/2022 |            | NORTHAM CHAMBER OF COMMERCE        | AD IN JULY ADVERTISER- DISPOSAL OF UNIT BY LEASE  | 1         | 181.50     |          |
| INV 000003728/06/2022 |            | NORTHAM CHAMBER OF COMMERCE        | SHIRE INCLUSION IN NORTHAM ADVERTISER- FULL PAGE- JULY 2022   | 1         | 440.00     |          |
| EFT44243              | 12/07/2022 | NORTHAM FEED & HIRE                | 6X ANIMAL CAGES   | 1         |            | 1,424.00 |
| INV 000042423/05/2022 |            | NORTHAM FEED & HIRE                | 6X ANIMAL CAGES   | 1         | 1,380.00   |          |
| INV 000042924/06/2022 |            | NORTHAM FEED & HIRE                | SWAN FOOD & OTHER MISCELLANEOUS ITEMS TILL 30/06/2022   | 1         | 44.00      |          |
| EFT44244              | 12/07/2022 | NORTHAM RAILWAYS FOOTBALL CLUB INC | 2021/22 QUICK RESPONSE GRANT PAYMENT - NAIDOC FOOTBALL GAME   | 1         |            | 2,900.00 |
| INV 2022-2422/06/2022 |            | NORTHAM RAILWAYS FOOTBALL CLUB INC | 2021/22 QUICK RESPONSE GRANT PAYMENT - NAIDOC FOOTBALL GAME   | 1         | 2,900.00   |          |
| EFT44245              | 12/07/2022 | NUTRIEN AG SOLUTIONS LIMITED       | PANZER 450 (GLYPHOSATE) 5 x 20L / TRIMAC WDG 5 x 5KG BOXES  | 1         |            | 6,270.95 |
| INV 907078409/06/2022 |            | NUTRIEN AG SOLUTIONS LIMITED       | PANZER 450 (GLYPHOSATE) 5 x 20L / TRIMAC WDG 5 x 5KG BOXES  | 1         | 5,387.25   |          |
| INV 907077909/06/2022 |            | NUTRIEN AG SOLUTIONS LIMITED       | FN2103 - CAM LOCK FITTINGS  | 1         | 95.82      |          |
| INV 907078409/06/2022 |            | NUTRIEN AG SOLUTIONS LIMITED       | REPLACEMENT GAS BOTTLE FOR PN1405 FORKLIFT  | 1         | 61.88      |          |
| INV 907182327/06/2022 |            | NUTRIEN AG SOLUTIONS LIMITED       | 20L DRUMS OF PANZER 450 GYLSOPHATE  | 1         | 726.00     |          |
| EFT44246              | 12/07/2022 | OXTER SERVICES                     | 12 OZ INDIG CUPS / WHITE PAPAER / FOOD CONTAINERS -NAIDOC   | 1         |            | 89.48    |

Ordinary Council Meeting Agenda  
17 August 2022



Date: 01/08/2022  
Time: 9:17:37AM

Shire of Northam

USER: Louise Harris  
PAGE: 24 10

| Cheque /EFT No        | Date       | Name                                       | Invoice Description   | Bank Code | INV Amount | Amount   |
|-----------------------|------------|--|---|-----------|------------|----------|
| INV 26007             | 06/07/2022 | OXTER SERVICES                             | 12 OZ INDIG CUPS / WHITE PAPAER / FOOD CONTAINERS -NAIDOC   | 1         | 89.48      |          |
| EFT44247              | 12/07/2022 | ROD QUIN AND ASSOCIATES - RODNEY QUIN T/AS | ROD QUIN BOOKS THE LIFE AND TIMES OF JOHN BEAZELEY  | 1         |            | 59.80    |
| INV 280620228/06/2022 |            | ROD QUIN AND ASSOCIATES - RODNEY QUIN T/AS | ROD QUIN BOOKS THE LIFE AND TIMES OF JOHN BEAZELEY  | 1         | 59.80      |          |
| EFT44248              | 12/07/2022 | ROYAL LIFE SAVING SOCIETY WA               | WUNDOWIE POOL CONDITIONS OF ENTRY SIGNAGE   | 1         |            | 434.50   |
| INV 172339            | 29/06/2022 | ROYAL LIFE SAVING SOCIETY WA               | WUNDOWIE POOL CONDITIONS OF ENTRY SIGNAGE   | 1         | 434.50     |          |
| EFT44249              | 12/07/2022 | SOUTHERN CROSS AUSTEREO PTY LTD            | 522 X 30 2 PER DAY SECOND RADIO COMMERCIALS ON TRIPLE M, NORTHAM  | 1         |            | 1,313.40 |
| INV 713424830/06/2022 |            | SOUTHERN CROSS AUSTEREO PTY LTD            | 522 X 30 2 PER DAY SECOND RADIO COMMERCIALS ON HIT FM NORTHAM AND MERREDIN PLUS MAXIMUM BONUS FILL ON BOTH STATIONS JUNE 2022 | 1         | 1,313.40   |          |
| EFT44250              | 12/07/2022 | SPECIALISED TREE SERVICE                   | VEGETATION CLEARING 0612 BRIDGE PEEL TERRACE  | 1         |            | 2,006.40 |
| INV 3882              | 30/06/2022 | SPECIALISED TREE SERVICE                   | VEGETATION CLEARING 0612 BRIDGE PEEL TERRACE  | 1         | 2,006.40   |          |
| EFT44251              | 12/07/2022 | SPORTSPOWER NORTHAM H & H JOUBERT          | WUNDOWIE POOL UNIFORMS  | 1         |            | 2,557.50 |
| INV 22-000030/06/2022 |            | SPORTSPOWER NORTHAM H & H JOUBERT          | NORTHAM POOL UNIFORMS   | 1         | 1,020.50   |          |
| INV 22-000030/06/2022 |            | SPORTSPOWER NORTHAM H & H JOUBERT          | WUNDOWIE POOL UNIFORMS  | 1         | 1,138.00   |          |
| INV 22-000005/07/2022 |            | SPORTSPOWER NORTHAM H & H JOUBERT          | NAVY VENTED BRIM HATS   | 1         | 399.00     |          |
| EFT44252              | 12/07/2022 | SWIFT OFFICE SOLUTIONS PTY LTD             | BKB - PRINTER INK CARTRIDGES  | 1         |            | 255.90   |
| INV 37678             | 17/05/2022 | SWIFT OFFICE SOLUTIONS PTY LTD             | BKB - PRINTER INK CARTRIDGES  | 1         | 255.90     |          |

Date: 01/08/2022  
Time: 9:17:37AM

Shire of Northam

USER: Louise Harris  
PAGE: 25 13

| Cheque /EFT No        | Date       | Name    | Invoice Description   | Bank Code | INV Amount | Amount    |
|-----------------------|------------|---------|---|-----------|------------|-----------|
| EFT44253              | 12/07/2022 | SYNERGY | 811029470 WUNDOWIE SWIMMING POOL - 29/04/2022 to 28/06/2022           | 1         |            | 12,970.89 |
| INV 135846505/01/2022 |            | SYNERGY | BAKERS HILL FIRE STATION - NOV 2021 TO JAN 2022                       | 1         | 339.02     |           |
| INV 135846504/03/2022 |            | SYNERGY | BAKERS HILL FIRE STATION - JAN 2022 TO MAR 2022                       | 1         | 407.42     |           |
| INV 135846505/05/2022 |            | SYNERGY | BAKERS HILL FIRE STATION - MAR 2022 TO MAY 2022                       | 1         | 349.18     |           |
| INV 796841316/06/2022 |            | SYNERGY | 796841340 SHIRE ADMINISTRATION BUILDING - 19/05/2022 to 15/06/2022    |           | 661.85     |           |
| INV 136537716/06/2022 |            | SYNERGY | 136537740 AIRPORT - 19/05/2022 to 15/06/2022                          |           | 1,120.16   |           |
| INV 361670216/06/2022 |            | SYNERGY | 361670250 NORTHAM LIBRARY - 19/05/2022 to 15/06/2022                  |           | 394.11     |           |
| INV 357549616/06/2022 |            | SYNERGY | 357549690 KILLARA DAYCARE CENTRE - COTTAGE - 19/05/2022 to 15/06/2022 |           | 1,058.31   |           |
| INV 361669521/06/2022 |            | SYNERGY | 361669500 OXIDATION PONDS - 17/05/2022 to 20/06/2022                  |           | 2,320.66   |           |
| INV 361990029/06/2022 |            | SYNERGY | 361990030 WUNDOWIE OVAL - 28/04/2022 to 28/06/2022                    |           | 250.91     |           |
| INV 916822729/06/2022 |            | SYNERGY | 916822750 WUNDOWIE TENNIS CLUB - 29/04/2022 to 28/06/2022             |           | 114.50     |           |
| INV 332273629/06/2022 |            | SYNERGY | 332273630 CLACKLINE POST OFFICE - 27/04/2022 to 24/06/2022            |           | 293.29     |           |
| INV 142275929/06/2022 |            | SYNERGY | 142275950 WUNDOWIE OVAL - 29/04/2022 to 28/06/2022                    |           | 452.32     |           |
| INV 288626729/06/2022 |            | SYNERGY | 288626740 CLACKLINE HALL - 27/04/2022 to 27/06/2022                   |           | 127.90     |           |
| INV 164007729/06/2022 |            | SYNERGY | 164007710 WUNDOWIE DEPOT - 29/04/2022 to 28/06/2022                   |           | 435.13     |           |
| INV 160396129/06/2022 |            | SYNERGY | 160396120 CLACKLINE FIRE SHED - 27/04/2022 to 24/06/2022              |           | 203.97     |           |
| INV 981292530/06/2022 |            | SYNERGY | 981292570 BAKERS HILL REC CENTRE - 30/04/2022 to 27/06/2022           |           | 851.18     |           |
| INV 811029430/06/2022 |            | SYNERGY | 811029470 WUNDOWIE SWIMMING POOL - 29/04/2022 to 28/06/2022           |           | 2,527.13   |           |
| INV 300677001/07/2022 |            | SYNERGY | 300677070 WUNDOWIE FOOTBALL PAVILLION - 04/05/2022 to 30/06/2022      |           | 261.04     |           |
| INV 962642901/07/2022 |            | SYNERGY | 962642990 WUNDOWIE MEDICAL CENTRE - 04/05/2022 to 30/06/2022          |           | 108.87     |           |
| INV 305307601/07/2022 |            | SYNERGY | 305307610 AGED ACCOMMODATION WUNDOWIE - 04/05/2022 to 30/06/2022      |           | 43.11      |           |

Date: 01/08/2022  
Time: 9:17:37AM

Shire of Northam

USER: Louise Harris  
PAGE: 26 10

| Cheque /EFT No | Date       | Name   | Invoice Description   | Bank Code | INV Amount | Amount    |
|----------------|------------|--|---|-----------|------------|-----------|
| INV 370639201  | 07/2022    | SYNERGY  | 370639230 WUNDOWIE TOWN HALL - 04/05/2022 to 30/06/2022   |           | 121.43     |           |
| INV 487964001  | 07/2022    | SYNERGY  | 487964040 WUNDOWIE YAK SHACK - 04/05/2022 to 30/06/2022   |           | 110.33     |           |
| INV 158509704  | 07/2022    | SYNERGY  | 158509760 BAKERS HILL BFB FIRE SHED - 27/04/2022 to 27/06/2022  |           | 130.39     |           |
| INV 135846505  | 07/2022    | SYNERGY  | BAKERS HILL FIRE STATION - APR 2022 TO JUNE 2022  | 1         | 288.68     |           |
| EFT44254       | 12/07/2022 | TENNANT AUSTRALIA  | REPAIRS TO T1B FLOOR CLEANING UNIT  | 1         |            | 642.18    |
| INV 918838901  | 07/2022    | TENNANT AUSTRALIA  | REPAIRS TO T1B FLOOR CLEANING UNIT  | 1         | 642.18     |           |
| EFT44255       | 12/07/2022 | THE PRINT SHOP BUNBURY                                       | 2000X NORTHAM VISITOR GUIDES FULL COLOUR, DOUBLE SIDED, MATTE FINISH, FOLDED  | 1         |            | 1,469.60  |
| INV 151269005  | 07/2022    | THE PRINT SHOP BUNBURY                                       | 2000X NORTHAM VISITOR GUIDES FULL COLOUR, DOUBLE SIDED, MATTE FINISH, FOLDED  | 1         | 1,469.60   |           |
| EFT44256       | 12/07/2022 | THINKPROJECT AUSTRALIA PTY LTD T-AS<br>RAMM SOFTWARE PTY LTD | RENTAL OF THE POCKET RAMM SOFTWARE FOR THE PERIOD 01 JUL 2021 TO 30 JUN 2022. THIS RENTAL ALLOWS YOU TO USE THIS SOFTWARE FOR ANY NUMBER OF CONTRACTS BUT ONLY ON EACH NAMED DEVICE THAT YOU HAVE PURCHASED. THIS IS NOT A CONCURRENT USER LICENSE AS EACH DEVICE MUST HAVE A LICENSE TO USE THE POCKET SOFTWARE / RAMM ANNUAL SUPPORT & MAINTENANCE FEE FOR THE PERIOD 01/07/2022-30/06/2023 | 1         |            | 10,943.54 |
| INV RSL-18     | 01/07/2022 | THINKPROJECT AUSTRALIA PTY LTD T-AS<br>RAMM SOFTWARE PTY LTD | RENTAL OF THE POCKET RAMM SOFTWARE FOR THE PERIOD 01 JUL 2021 TO 30 JUN 2022. THIS RENTAL ALLOWS YOU TO USE THIS SOFTWARE FOR ANY NUMBER OF CONTRACTS BUT ONLY ON EACH NAMED DEVICE THAT YOU HAVE PURCHASED. THIS IS NOT A CONCURRENT USER LICENSE AS EACH DEVICE MUST HAVE A LICENSE TO USE THE POCKET SOFTWARE / RAMM ANNUAL SUPPORT & MAINTENANCE FEE FOR THE PERIOD 01/07/2022-30/06/2023 | 1         | 10,943.54  |           |
| EFT44257       | 12/07/2022 | TOLL - IPEC PTY LTD T/AS                                     | TOLL FREIGHT CHARGES TO 03/04/2022 - CESM / HEALTH / LIBRARY / DEPOT  | 1         |            | 129.68    |

Date: 01/08/2022  
Time: 9:17:37AM

Shire of Northam

USER: Louise Harris  
PAGE: 27 13

| Cheque /EFT No        | Date       | Name  | Invoice Description   | Bank Code | INV Amount | Amount   |
|-----------------------|------------|---|---|-----------|------------|----------|
| INV 0538-S303/04/2022 |            | TOLL - IPEC PTY LTD T/AS                        | TOLL FREIGHT CHARGES TO 03/04/2022 - CESM / HEALTH / LIBRARY / DEPOT  | 1         | 85.79      |          |
| INV 0547-S305/06/2022 |            | TOLL - IPEC PTY LTD T/AS                        | TOLL FREIGHT CHARGES - 05 JUNE 2022 - CESM / DEPOT  | 1         | 43.89      |          |
| EFT44258              | 12/07/2022 | TREVOR EASTWELL                                 | DRIVING FOR WUNDOWIE TO NORTHAM COMMUNITY TRANSPORT 23/06/2022  | 1         |            | 100.00   |
| INV 94                | 07/07/2022 | TREVOR EASTWELL                                 | DRIVING FOR WUNDOWIE TO NORTHAM COMMUNITY TRANSPORT 23/06/2022  | 1         | 50.00      |          |
| INV 95                | 07/07/2022 | TREVOR EASTWELL                                 | DRIVING FOR WUNDOWIE TO NORTHAM COMMUNITY TRANSPORT 7 JULY 2022   | 1         | 50.00      |          |
| EFT44259              | 12/07/2022 | TYREPOWER LTD                                   | REPAIR REAR VEHICLE TYRE THAT IS GOING FLAT   | 1         |            | 31.08    |
| INV 8265-1422/06/2022 |            | TYREPOWER LTD                                   | REPAIR REAR VEHICLE TYRE THAT IS GOING FLAT   | 1         | 31.08      |          |
| EFT44260              | 12/07/2022 | WA RETICULATION SUPPLIES                        | RETICULATION ELBOW 63MM TO 50MM   | 1         |            | 35.46    |
| INV M5467 04/05/2022  |            | WA RETICULATION SUPPLIES                        | RETICULATION ELBOW 63MM TO 50MM   | 1         | 35.46      |          |
| EFT44261              | 12/07/2022 | WAY SIGNS                                       | 6 X1200 MM WIDE X 800 MM EXTERIOR HIGH METAL SIGNS FOR THE INKPEN TIP - SOLID BLACK TEXT AND SOLID YELLOW ARROWS - TIP FACE, GREEN WASTE, SCRAP METAL, ETC. \$198 EACH INCL. GST. | 1         |            | 1,188.00 |
| INV INV-29024/04/2022 |            | WAY SIGNS                                       | 6 X1200 MM WIDE X 800 MM EXTERIOR HIGH METAL SIGNS FOR THE INKPEN TIP - SOLID BLACK TEXT AND SOLID YELLOW ARROWS - TIP FACE, GREEN WASTE, SCRAP METAL, ETC. \$198 EACH INCL. GST. | 1         | 1,188.00   |          |
| EFT44262              | 12/07/2022 | WESTERN AUSTRALIAN LOCAL GOVERNMENT ASSOCIATION | INTRODUCTION TO PLANNING (ELEARNING) BOBBI-JO WISE  | 1         |            | 214.50   |
| INV I30934426/05/2022 |            | WESTERN AUSTRALIAN LOCAL GOVERNMENT ASSOCIATION | INTRODUCTION TO PLANNING (ELEARNING) BOBBI-JO WISE  | 1         | 214.50     |          |
| EFT44263              | 12/07/2022 | WESTWIDE AUTO ELECTRICS AND AIR CONDITIONING    | FN1805 - TEST, SUPPLY AND REPLACE ISOLATOR TO RESPONSE TRUCK  | 1         |            | 880.70   |
| INV INV-13714/06/2022 |            | WESTWIDE AUTO ELECTRICS AND AIR CONDITIONING    | FN1511 - REPLACE BATTERY  | 1         | 405.70     |          |
| INV INV-13730/06/2022 |            | WESTWIDE AUTO ELECTRICS AND AIR CONDITIONING    | FN1805 - TEST, SUPPLY AND REPLACE ISOLATOR TO RESPONSE TRUCK  | 1         | 475.00     |          |

Date: 01/08/2022  
Time: 9:17:37AM

Shire of Northam

USER: Louise Harris  
PAGE: 28 10

| Cheque /EFT No | Date       | Name                                       | Invoice Description   | Bank Code | INV Amount | Amount    |
|----------------|------------|--|---|-----------|------------|-----------|
| EFT44264       | 12/07/2022 | WREN OIL                                   | ATTEND OLD QUARRY TIP SITE<br>EMPTY WASTE OIL   | 1         |            | 16.50     |
| INV 133348     | 28/06/2022 | WREN OIL                                   | CHARGES FOR ADMIN & COMPLIANCE FEES<br>ATTEND OLD QUARRY TIP SITE<br>EMPTY WASTE OIL<br>CHARGES FOR ADMIN & COMPLIANCE FEES | 1         | 16.50      |           |
| EFT44265       | 14/07/2022 | ADEPT PHOTO BOOTHS - COLIN RICHARDSON T/AS | WORKSHOP - SEVEN STEPS TO SPONSORSHIP SUCCESS   | 1         |            | 596.82    |
| INV 000013727  | 05/2022    | ADEPT PHOTO BOOTHS - COLIN RICHARDSON T/AS | WORKSHOP - SEVEN STEPS TO SPONSORSHIP SUCCESS   | 1         | 596.82     |           |
| EFT44266       | 14/07/2022 | AMPAC DEBT RECOVERY (WA) P/L               | DEBT COLLECTION FOR PERIOD ENDING JUNE 2022   | 1         |            | 503.25    |
| INV 85426      | 30/06/2022 | AMPAC DEBT RECOVERY (WA) P/L               | DEBT COLLECTION FOR PERIOD ENDING JUNE 2022   | 1         | 503.25     |           |
| EFT44267       | 14/07/2022 | ANDREW DAMIEN SMITH                        | RATES CREDIT REFUND FOR ASSESSMENT A15505   | 1         |            | 2,175.96  |
| INV A15505     | 14/07/2022 | ANDREW DAMIEN SMITH                        | RATES CREDIT REFUND FOR ASSESSMENT A15505   |           | 2,175.96   |           |
| EFT44268       | 14/07/2022 | ASTRO TOURISM WA PTY LTD                   | ASTRO PHOTOGRAPHY WORKSHOP - 21 APRIL 2022<br>PROMOTIONAL POSTER & 2 ASTRO TOURISM STAFF                                    | 1         |            | 2,750.00  |
| INV 1137       | 22/04/2022 | ASTRO TOURISM WA PTY LTD                   | ASTRO PHOTOGRAPHY WORKSHOP - 21 APRIL 2022<br>PROMOTIONAL POSTER & 2 ASTRO TOURISM STAFF                                    | 1         | 2,750.00   |           |
| EFT44269       | 14/07/2022 | AUSTRALIAN TAXATION OFFICE - PAYG          | PAYG FOR PAY WEEK ENDING 05/7/2022  | 1         |            | 61,655.32 |
| INV PAYG 008   | 07/2022    | AUSTRALIAN TAXATION OFFICE - PAYG          | PAYG FOR PAY WEEK ENDING 05/7/2022  | 1         | 61,655.32  |           |
| EFT44270       | 14/07/2022 | AVON WASTE                                 | MANAGEMENT AT INKPEN LANDFILL FACILITY - JUNE 2022  | 1         |            | 16,044.60 |
| INV 000509230  | 06/2022    | AVON WASTE                                 | MANAGEMENT AT INKPEN LANDFILL FACILITY - JUNE 2022  | 1         | 16,044.60  |           |
| EFT44271       | 14/07/2022 | BUSINESS FUEL CARDS PTY LTD (FLEET CARD)   | FUEL CHARGES FOR JUNE 2022  | 1         |            | 402.98    |
| INV JUNE 2     | 30/06/2022 | BUSINESS FUEL CARDS PTY LTD (FLEET CARD)   | FUEL CHARGES FOR JUNE 2022  | 1         | 402.98     |           |
| EFT44272       | 14/07/2022 | CENTRAL MOBILE MECHANICAL REPAIRS          | PICK UP STEEL DRUM ROLLER FROM NORTHAM DEPOT AND DROP OFF AT PARKER ROAD  | 1         |            | 709.50    |

Date: 01/08/2022  
Time: 9:17:37AM

Shire of Northam

USER: Louise Harris  
PAGE: 29 13

| Cheque /EFT No        | Date       | Name  | Invoice Description  | Bank Code | INV Amount | Amount   |
|-----------------------|------------|---|--|-----------|------------|----------|
| INV 000040302/06/2022 |            | CENTRAL MOBILE MECHANICAL REPAIRS                             | PICK UP STEEL DRUM ROLLER FROMNORTHAM DEPOT AND DROP OFF AT PARKER ROAD                | 1         | 709.50     |          |
| EFT44273              | 14/07/2022 | CLIFFORD JOHN MCLACHLAN                                       | RATES CREDIT REFUND FOR ASSESSMENT A2163   | 1         |            | 736.85   |
| INV A2163             | 14/07/2022 | CLIFFORD JOHN MCLACHLAN                                       | RATES CREDIT REFUND FOR ASSESSMENT A2163   |           | 736.85     |          |
| EFT44274              | 14/07/2022 | CRYSTAL PRINTING SOLUTIONS PTY LTD<br>T/A WORLWIDE EAST PERTH | 2022-23 RESIDENTIAL TIP PASS   | 1         |            | 1,144.00 |
| INV 109769428/06/2022 |            | CRYSTAL PRINTING SOLUTIONS PTY LTD<br>T/A WORLWIDE EAST PERTH | 2022-23 RESIDENTIAL TIP PASS   | 1         | 1,144.00   |          |
| EFT44275              | 14/07/2022 | CYNDY MOODY   | CYNDY MOODY<br>FOR NAIDOC PERFORMANCE DONE<br>@ BIL YA KOORT BOODJA<br>07-07-2022      | 1         |            | 1,000.00 |
| INV 069               | 28/06/2022 | CYNDY MOODY   | CYNDY MOODY<br>FOR NAIDOC PERFORMANCE DONE<br>@ BIL YA KOORT BOODJA<br>07-07-2022      | 1         | 1,000.00   |          |
| EFT44276              | 14/07/2022 | DCM CARPENTRY & MAINTENANCE                                   | TOWN HALL. REPLACE ARCH DOOR TO THE TOP OF STAIRS.                                     | 1         |            | 1,580.70 |
| INV 1415              | 27/06/2022 | DCM CARPENTRY & MAINTENANCE                                   | TOWN HALL. REPLACE ARCH DOOR TO THE TOP OF STAIRS.                                     | 1         | 988.90     |          |
| INV 1416              | 28/06/2022 | DCM CARPENTRY & MAINTENANCE                                   | SUSPENSION BRIDGE. REPLACE BROKEN BOARD NEAR BKB END.                                  | 1         | 327.80     |          |
| INV 1418              | 05/07/2022 | DCM CARPENTRY & MAINTENANCE                                   | KILLARA RESIT CARE. REPAIR TO SLIDING DOOR TO DINING ROOM AFTER FRIDAY NIGHT BREAK IN. | 1         | 192.50     |          |
| INV 1417              | 05/07/2022 | DCM CARPENTRY & MAINTENANCE                                   | NORTHAM DEPOT. REPAIR ENTRY DOOR.  | 1         | 71.50      |          |
| EFT44277              | 14/07/2022 | DEBORAH MOODY   | DEBORAH MOODY<br>FOR WELCOMING FAMILY TO NAIDOC<br>@ BIL YA KOORT BOODJA<br>07-07-2022 | 1         |            | 300.00   |
| INV 1                 | 07/07/2022 | DEBORAH MOODY   | DEBORAH MOODY<br>FOR WELCOMING FAMILY TO NAIDOC<br>@ BIL YA KOORT BOODJA<br>07-07-2022 | 1         | 300.00     |          |

Date: 01/08/2022  
Time: 9:17:37AM

Shire of Northam

USER: Louise Harris  
PAGE: 30 10

| Cheque /EFT No         | Date       | Name  | Invoice Description   | Bank Code | INV Amount | Amount    |
|------------------------|------------|---|---|-----------|------------|-----------|
| EFT44278               | 14/07/2022 | DMC CLEANING                                    | CLEANING OF NORTHAM FACILITES - CONSUMABLE PRODUCTS - 01/06/2022  | 1         |            | 1,467.65  |
| INV SON20828/06/2022   |            | DMC CLEANING                                    | CLEANING OF NORTHAM FACILITES - CONSUMABLE PRODUCTS - 01/06/2022  | 1         | 1,099.18   |           |
| INV SON20904/07/2022   |            | DMC CLEANING                                    | CLEANING SHIRE OF NORTHAM FACILITES - CONSUMABLE PRODUCTS PROVIDED - 28/06/2022   | 1         | 368.47     |           |
| EFT44279               | 14/07/2022 | DUN DIRECT PTY LTD                              | FUEL CHARGES FOR JUNE 2022  | 1         |            | 34,668.72 |
| INV JUNE 2 30/06/2022  |            | DUN DIRECT PTY LTD                              | FUEL CHARGES FOR JUNE 2022  | 1         | 34,668.72  |           |
| EFT44280               | 14/07/2022 | E FIRE & SAFETY                                 | MONTHLY ROUTINE MAINTENANCE CHARGES FOR THE TESTING OF THE FIRE DETECTION SYSTEM AT NORTHAM TOWN HALL 01/06/2022 - 30/06/2022 | 1         |            | 162.80    |
| INV 566577 30/06/2022  |            | E FIRE & SAFETY                                 | MONTHLY ROUTINE MAINTENANCE CHARGES FOR THE TESTING OF THE FIRE DETECTION SYSTEM AT NORTHAM TOWN HALL 01/06/2022 - 30/06/2022 | 1         | 162.80     |           |
| EFT44281               | 14/07/2022 | EQUIFAX AUSTRALASIA WORKFORCE SOLUTIONS PTY LTD | INDIVIDUAL REPORTS FOR NEW VOLUNTEER FIREFIGHTING MEMBERS - JUNE 2022   | 1         |            | 400.07    |
| INV 150916231/03/2022  |            | EQUIFAX AUSTRALASIA WORKFORCE SOLUTIONS PTY LTD | INDIVIDUAL REPORTS FOR NEW VOLUNTEER FIREFIGHTING MEMBERS - MARCH 2022  | 1         | 125.07     |           |
| INV 151536830/06/2022  |            | EQUIFAX AUSTRALASIA WORKFORCE SOLUTIONS PTY LTD | INDIVIDUAL REPORTS FOR NEW VOLUNTEER FIREFIGHTING MEMBERS - JUNE 2022   | 1         | 275.00     |           |
| EFT44282               | 14/07/2022 | EQUITY SETTLEMENTS                              | RATES CREDIT REFUND FOR ASSESSMENT A12579   | 1         |            | 603.61    |
| INV A12579 14/07/2022  |            | EQUITY SETTLEMENTS                              | RATES CREDIT REFUND FOR ASSESSMENT A12579   |           | 603.61     |           |
| EFT44283               | 14/07/2022 | FINISHING WA                                    | BINDING OF COUNCIL MINUTES  | 1         |            | 1,213.30  |
| INV INV -16730/06/2022 |            | FINISHING WA                                    | BINDING OF COUNCIL MINUTES  | 1         | 1,213.30   |           |
| EFT44284               | 14/07/2022 | FRANK DAVIS                                     | WTC + DIDGERIDOO PLAY + STORY TELLING DONE BY FRANK DAVIS FOR GROWER GROUP ALLIANCE ON 28-06-2022                             | 1         |            | 1,500.00  |
| INV 11 28/06/2022      |            | FRANK DAVIS                                     | WTC + DIDGERIDOO PLAY + STORY TELLING DONE BY FRANK DAVIS FOR GROWER GROUP ALLIANCE ON 28-06-2022                             | 1         | 1,500.00   |           |



Ordinary Council Meeting Agenda  
17 August 2022



Date: 01/08/2022  
Time: 9:17:37AM

Shire of Northam

USER: Louise Harris  
PAGE: 31 13

| Cheque /EFT No        | Date       | Name  | Invoice Description   | Bank Code | INV Amount | Amount     |
|-----------------------|------------|---|---|-----------|------------|------------|
| EFT44285              | 14/07/2022 | GOODYEAR & DUNLOP TYRES (AUST) PTY LTD        | FN1805 - SUPPLY AND FIT TWO TYRES TO RESPONSE TRUCK AS PER QUOTE U524362892                                   | 1         |            | 1,349.16   |
| INV 641264730/06/2022 |            | GOODYEAR & DUNLOP TYRES (AUST) PTY LTD        | FN1805 - SUPPLY AND FIT TWO TYRES TO RESPONSE TRUCK AS PER QUOTE U524362892                                   | 1         | 1,349.16   |            |
| EFT44286              | 14/07/2022 | GRAFTON ELECTRICS                             | OLD BAKERS HILL FIRE SHED. REPLACE POWE POLE AS PER INSTRUCTION BY WESTER POWER ON RECORD I111105. QUOTE 137. | 1         |            | 4,114.00   |
| INV 8564              | 08/04/2022 | GRAFTON ELECTRICS                             | OLD BAKERS HILL FIRE SHED. REPLACE POWE POLE AS PER INSTRUCTION BY WESTER POWER ON RECORD I111105. QUOTE 137. | 1         | 3,696.00   |            |
| INV 8783              | 21/06/2022 | GRAFTON ELECTRICS                             | REPAIR TO BBQ AREA LIGHTS THAT ARE TRIPPING. RCD CHECKED AND SWITCH WILL NOT GO BACK ON.                      | 1         | 418.00     |            |
| EFT44287              | 14/07/2022 | GROVE WESLEY DESIGN ART                       | NAME BADGES X 4   | 1         |            | 69.20      |
| INV 7083              | 30/06/2022 | GROVE WESLEY DESIGN ART                       | NAME BADGES X 4   | 1         | 69.20      |            |
| EFT44288              | 14/07/2022 | HAWK CONCRETE FLOOR COATINGS - RCJ TRUST T/AS | BERNARD PARK TOILETS. GENERATOR HIRE FOR FLOOR GRINDING.  | 1         |            | 825.00     |
| INV INV-63930/06/2022 |            | HAWK CONCRETE FLOOR COATINGS - RCJ TRUST T/AS | BERNARD PARK TOILETS. GENERATOR HIRE FOR FLOOR GRINDING.  | 1         | 825.00     |            |
| EFT44289              | 14/07/2022 | IT VISION                                     | RENEW SYNERGYSOFT & UNIVERSE ANNUAL LICENSE FEES 01 JULY 2022-30 JUNE 2023                                    | 1         |            | 100,699.50 |
| INV 37166             | 01/07/2022 | IT VISION                                     | RENEW SYNERGYSOFT & UNIVERSE ANNUAL LICENSE FEES 01 JULY 2022-30 JUNE 2023                                    | 1         | 100,699.50 |            |
| EFT44290              | 14/07/2022 | LANDGATE                                      | GROSS RENTAL VALUES REVALUATION 2021/22 COUNTRY REGION  | 1         |            | 92,689.67  |
| INV 375452            | 02/06/2022 | LANDGATE                                      | COUNTRY URBAN UV REVALUATION 2021/2022  | 1         | 164.20     |            |
| INV 375657            | 14/06/2022 | LANDGATE                                      | GROSS RENTAL VALUES REVALUATION 2021/22 COUNTRY REGION  | 1         | 91,649.70  |            |
| INV 375870            | 23/06/2022 | LANDGATE                                      | GROSS RENTAL VALUATIONS CHARGEABLE SCHEDULE G2022/7 FROM 14/05/2022 TO 10/06/2022                             | 1         | 299.37     |            |
| INV 119741401/07/2022 |            | LANDGATE                                      | PURCHASE OF 2021 AERIAL PHOTOGRAPHY FOR THE SHIRE OF NORTHAM  | 1         | 576.40     |            |

Ordinary Council Meeting Agenda  
17 August 2022



Date: 01/08/2022  
Time: 9:17:37AM

Shire of Northam

USER: Louise Harris  
PAGE: 32 10

| Cheque /EFT No        | Date       | Name  | Invoice Description  | Bank Code | INV Amount | Amount    |
|-----------------------|------------|---|--|-----------|------------|-----------|
| EFT44291              | 14/07/2022 | LFA FIRST RESPONSE                                    | FIRST AID POLY WALL SIGN 225 X 225MM / VENTOLIN INHALER 200 METERED DOSES / LE PETITE SPACER | 1         |            | 176.90    |
| INV IN2509407/07/2022 |            | LFA FIRST RESPONSE                                    | FIRST AID POLY WALL SIGN 225 X 225MM / VENTOLIN INHALER 200 METERED DOSES / LE PETITE SPACER | 1         | 176.90     |           |
| EFT44292              | 14/07/2022 | LGIS - LOCAL GOVERNMENT INSURANCE SERVICES            | MARINE CARGO ANNUAL INSURANCE PREMIUMS 30/06/2022-30/06/2023                                 | 1         |            | 9,992.29  |
| INV 062-21230/06/2022 |            | LGIS - LOCAL GOVERNMENT INSURANCE SERVICES            | MARINE CARGO ANNUAL INSURANCE PREMIUMS 30/06/2022-30/06/2023                                 | 1         | 1,039.50   |           |
| INV 062-21230/06/2022 |            | LGIS - LOCAL GOVERNMENT INSURANCE SERVICES            | MARINE CARGO ANNUAL INSURANCE PREMIUMS 30/06/2022-30/06/2023                                 | 1         | 8,952.79   |           |
| EFT44293              | 14/07/2022 | LOCAL GOVERNMENT PROFESSIONALS AUSTRALIA WA           | LOCAL GOVERNMENT PROFESSIONALS MEMBERSHIP RENEWAL FOR CHADD HUNT                             | 1         |            | 531.00    |
| INV 27027 01/07/2022  |            | LOCAL GOVERNMENT PROFESSIONALS AUSTRALIA WA           | LOCAL GOVERNMENT PROFESSIONALS MEMBERSHIP RENEWAL FOR CHADD HUNT                             | 1         | 531.00     |           |
| EFT44294              | 14/07/2022 | LUCY'S TEAROOMS                                       | CATERING (LUNCH) STAFF TRAINING - DEALING WITH DIFFICULT CUSTOMERS (MAY 25TH & MAY 26TH      | 1         |            | 425.00    |
| INV 2716              | 08/06/2022 | LUCY'S TEAROOMS                                       | CATERING (LUNCH) STAFF TRAINING - DEALING WITH DIFFICULT CUSTOMERS (MAY 25TH & MAY 26TH      | 1         | 425.00     |           |
| EFT44295              | 14/07/2022 | MACRI PARTNERS  | FINANCIAL MANAGEMENT REVIEW 21/22  | 1         |            | 19,800.00 |
| INV 48121 30/06/2022  |            | MACRI PARTNERS  |  | 1         | 19,800.00  |           |
| EFT44296              | 14/07/2022 | MAYDAY EARTHMOVING / RENTAL - CHIVAS ENTERPRISES T-AS | DOZER DRY HIRE - 23/6 - 30/6/22  | 1         |            | 9,548.00  |
| INV 82361             | 30/06/2022 | MAYDAY EARTHMOVING / RENTAL - CHIVAS ENTERPRISES T-AS | DOZER DRY HIRE - 23/6 - 30/6/22  | 1         | 9,548.00   |           |
| EFT44297              | 14/07/2022 | NIGEL WILLIAM FEEKE                                   | RATES CREDIT REFUND FOR ASSESSMENT A1763   | 1         |            | 750.17    |
| INV A1763             | 14/07/2022 | NIGEL WILLIAM FEEKE                                   | RATES CREDIT REFUND FOR ASSESSMENT A1763   |           | 750.17     |           |
| EFT44298              | 14/07/2022 | NORTHAM FEED & HIRE                                   | SWAN FOOD & OTHER MISCELLANEOUS ITEMS - JULY 2022  | 1         |            | 127.00    |
| INV 000043030/06/2022 |            | NORTHAM FEED & HIRE                                   | SWAN FOOD & OTHER MISCELLANEOUS ITEMS - JUNE 2022  | 1         | 44.00      |           |
| INV 000043006/07/2022 |            | NORTHAM FEED & HIRE                                   | SWAN FOOD & OTHER MISCELLANEOUS ITEMS - JULY 2022  | 1         | 36.00      |           |

Ordinary Council Meeting Agenda  
17 August 2022



Date: 01/08/2022  
Time: 9:17:37AM

Shire of Northam

USER: Louise Harris  
PAGE: 33 13

| Cheque /EFT No         | Date       | Name   | Invoice Description  | Bank Code | INV Amount | Amount   |
|------------------------|------------|--|--|-----------|------------|----------|
| INV 000043107/07/2022  |            | NORTHAM FEED & HIRE                            | SWAN FOOD & OTHER MISCELLANEOUS ITEMS - JULY 2022  | 1         | 47.00      |          |
| EFT44299               | 14/07/2022 | OFFICEWORKS SUPERSTORES PTY LTD                | PACK & ROLL 35KG TROLLEY CART BLACK / AVERY PRINTABLE TABBIES WHITE 48 PACK  | 1         |            | 198.91   |
| INV 601673005/07/2022  |            | OFFICEWORKS SUPERSTORES PTY LTD                | PACK & ROLL 35KG TROLLEY CART BLACK / AVERY PRINTABLE TABBIES WHITE 48 PACK  | 1         | 198.91     |          |
| EFT44300               | 14/07/2022 | PJ & DE ROBINSON                               | NORTHAM TOY LIBRARY. TREAT MOULD ON WALLS AND CLEAN AFFECTED AREAS.  | 1         |            | 440.00   |
| INV 600004701/07/2022  |            | PJ & DE ROBINSON                               | NORTHAM TOY LIBRARY. TREAT MOULD ON WALLS AND CLEAN AFFECTED AREAS.  | 1         | 440.00     |          |
| EFT44301               | 14/07/2022 | REGIONAL CONCRETE & LANDSCAPE                  | REFUND FOR THE DEVELOPMENT APPLICATION P22068 FEE AS NOT REQUIRED R/N 155521   | 1         |            | 147.00   |
| INV JJ2906229/06/2022  |            | REGIONAL CONCRETE & LANDSCAPE                  | REFUND FOR THE DEVELOPMENT APPLICATION P22068 FEE AS NOT REQUIRED R/N 155521   | 1         | 147.00     |          |
| EFT44302               | 14/07/2022 | SAFE T CARD AUSTRALIA PTY LTD                  | VISTORS CENTRE / KILLARA / LIBRARY / DEVELOPMENT SERVICES - SAFETCARD DEVICE QUARTLEY MONITORING FEES JULY - SEPT 2022 | 1         |            | 924.00   |
| INV INV -30301/07/2022 |            | SAFE T CARD AUSTRALIA PTY LTD                  | VISTORS CENTRE / KILLARA / LIBRARY / DEVELOPMENT SERVICES - SAFETCARD DEVICE QUARTLEY MONITORING FEES JULY - SEPT 2022 | 1         | 924.00     |          |
| EFT44303               | 14/07/2022 | SOUTHERN CROSS AUSTEREO PTY LTD                | AROUND THE TOWNS INTERVIEWS - SHIRE PRESIDENT - JUNE 2022  | 1         |            | 198.00   |
| INV 713424830/06/2022  |            | SOUTHERN CROSS AUSTEREO PTY LTD                | AROUND THE TOWNS INTERVIEWS - SHIRE PRESIDENT - JUNE 2022  | 1         | 198.00     |          |
| EFT44304               | 14/07/2022 | SPECIALE SMASH REPAIRS                         | FN2015 - N11131 - INSURANCE EXCESS   | 1         |            | 1,000.00 |
| INV 20745/217/06/2022  |            | SPECIALE SMASH REPAIRS                         | FN2015 - N11131 - INSURANCE EXCESS   | 1         | 1,000.00   |          |
| EFT44305               | 14/07/2022 | ST JOHN AMBULANCE AUSTRALIA (FIRST AID COURSE) | ELIJAH MOOREHEAD USI# KHMCRYHQHY FIRST AT REFRESHER AT NORTHAM FACILITY 23/06/2022                                     | 1         |            | 160.00   |
| INV FAINV023/06/2022   |            | ST JOHN AMBULANCE AUSTRALIA (FIRST AID COURSE) | ELIJAH MOOREHEAD USI# KHMCRYHQHY FIRST AT REFRESHER AT NORTHAM FACILITY 23/06/2022                                     | 1         | 160.00     |          |

Date: 01/08/2022  
Time: 9:17:37AM

Shire of Northam

USER: Louise Harris  
PAGE: 34 10

| Cheque /EFT No        | Date       | Name  | Invoice Description   | Bank Code | INV Amount | Amount    |
|-----------------------|------------|---|---|-----------|------------|-----------|
| EFT44306              | 14/07/2022 | T-QUIP  | PN2106 - PERUZZO PANTHER PROFESSIONAL 1800 HI-LIFT MOWER PARTS AND REPAIRS ON SITE AS PER QUOTATION 18437 #9. PLUS EXTRA LABOUR COSTS | 1         |            | 6,248.70  |
| INV 111670            | 01/07/2022 | T-QUIP  | PN2106 - PERUZZO PANTHER PROFESSIONAL 1800 HI-LIFT MOWER PARTS AND REPAIRS ON SITE AS PER QUOTATION 18437 #9. PLUS EXTRA LABOUR COSTS | 1         | 6,248.70   |           |
| EFT44307              | 14/07/2022 | TOTALLY WORKWEAR MALAGA                       | 50 X CMK-4 COMMUTER FACE MASKS - BLACK  | 1         |            | 575.00    |
| INV 750014520/04/2022 |            | TOTALLY WORKWEAR MALAGA                       | 50 X CMK-4 COMMUTER FACE MASKS - BLACK  | 1         | 575.00     |           |
| EFT44308              | 14/07/2022 | TRANSWEST WA AUSTRALIAN STONE COMPANY PTY LTD | 19MM GRAVEL MRD SPEC  | 1         |            | 7,182.25  |
| INV INV-28930/06/2022 |            | TRANSWEST WA AUSTRALIAN STONE COMPANY PTY LTD | 100 TONNE X 19MM GRAVEL MRD SPEC - DELIVERED TO NORTHAM DEPOT   | 1         | 1,955.05   |           |
| INV INV-28730/06/2022 |            | TRANSWEST WA AUSTRALIAN STONE COMPANY PTY LTD | 19MM GRAVEL MRD SPEC  | 1         | 1,267.20   |           |
| INV INV-28930/06/2022 |            | TRANSWEST WA AUSTRALIAN STONE COMPANY PTY LTD | 19MM GRAVEL MRD SPEC  | 1         | 3,960.00   |           |
| EFT44309              | 14/07/2022 | TYREPOWER LTD                                 | TYRE REPAIR ON CEO VEHICLE  | 1         |            | 31.08     |
| INV 8265.1401/07/2022 |            | TYREPOWER LTD                                 | TYRE REPAIR ON CEO VEHICLE  | 1         | 31.08      |           |
| EFT44310              | 14/07/2022 | WARRICKS NEWSAGENCY                           | LIBRARY - MAGAZINE SUBSCRIPTIONS - JUNE 2022  | 1         |            | 315.77    |
| INV 79533 07/04/2022  |            | WARRICKS NEWSAGENCY                           | LABEL AVERY LASER L6011 H/DUTY SILVER 27UP PKT20 /MANILLA FOLDERS   | 1         | 86.70      |           |
| INV SN00 0130/06/2022 |            | WARRICKS NEWSAGENCY                           | LIBRARY - MAGAZINE SUBSCRIPTIONS - JUNE 2022  | 1         | 229.07     |           |
| EFT44311              | 14/07/2022 | WESTERN AUSTRALIAN TREASURY CORPORATION       | GOVERNMENT GUARANTEE FEE FOR THE PERIOD ENDING 30/06/2022   | 1         |            | 20,092.14 |
| INV GFEE J 30/06/2022 |            | WESTERN AUSTRALIAN TREASURY CORPORATION       | GOVERNMENT GUARANTEE FEE FOR THE PERIOD ENDING 30/06/2022   | 1         | 20,092.14  |           |
| EFT44312              | 14/07/2022 | WESTWIDE AUTO ELECTRICS AND AIR CONDITIONING  | PN1003 - JUMPSTART/ DIAGNOSE AND BATTERY REPLACEMENT  | 1         |            | 5,048.00  |
| INV INV-13501/05/2022 |            | WESTWIDE AUTO ELECTRICS AND AIR CONDITIONING  | INKPEN 3.4U - ATTEND STATION, DIAGNOSE BATTERY FAULT AND REPLACE AS REQUIRED  | 1         | 242.50     |           |

Date: 01/08/2022  
Time: 9:17:37AM

Shire of Northam

USER: Louise Harris  
PAGE: 35 13

| Cheque /EFT No        | Date       | Name   | Invoice Description   | Bank Code | INV Amount | Amount |
|-----------------------|------------|--|---|-----------|------------|--------|
| INV INV-13501/05/2022 |            | WESTWIDE AUTO ELECTRICS AND AIR CONDITIONING         | INKPEN 3.4U - ATTEND STATION, DIAGNOSE BATTERY FAULT AND REPLACE AS REQUIRED  | 1         | 712.50     |        |
| INV INV-13509/05/2022 |            | WESTWIDE AUTO ELECTRICS AND AIR CONDITIONING         | NEW BATTERY - WUNDOWIE LT   | 1         | 917.50     |        |
| INV INV-13613/06/2022 |            | WESTWIDE AUTO ELECTRICS AND AIR CONDITIONING         | FN0916 - BATTERY FOR CLARK BOBCAT   | 1         | 505.00     |        |
| INV INV-13617/06/2022 |            | WESTWIDE AUTO ELECTRICS AND AIR CONDITIONING         | NORTHAM CENTRAL 3.4 - DIAGNOSE AND REPAIR FUSE ISSUE WITH CENTRE CONSOLE, TEST ALL SYSTEMS TO ENSURE AMBER BEACONS AND ALL OTHER SYSTEMS ARE FUNCTIONING AS PER MANUFACTURE SPECS | 1         | 247.50     |        |
| INV INV-13730/06/2022 |            | WESTWIDE AUTO ELECTRICS AND AIR CONDITIONING         | FN1611 - REPLACE REMOTE AERIEL FOR WATER TRUCK PUMP   | 1         | 217.50     |        |
| INV INV-13730/06/2022 |            | WESTWIDE AUTO ELECTRICS AND AIR CONDITIONING         | REPLACE BATTERY ON IRISHTOWN FIRE APPLIANCE   | 1         | 762.50     |        |
| INV INV-13730/06/2022 |            | WESTWIDE AUTO ELECTRICS AND AIR CONDITIONING         | FN1003 - JUMPSTART/ DIAGNOSE AND BATTERY REPLACEMENT  | 1         | 1,097.50   |        |
| INV INV-13730/06/2022 |            | WESTWIDE AUTO ELECTRICS AND AIR CONDITIONING         | FN2012 - N11254 - INVESTIGATE EMERGENCY LIGHT ISSUE   | 1         | 345.50     |        |
| EFT44313              | 14/07/2022 | WHEATBELT OFFICE & BUSINESS MACHINES (WOBM)          | CREATE298 - MONTHLY PHOTOCOPIER READING - 06/06/2022 - 04/07/2022   | 1         |            | 58.90  |
| INV 214207            | 04/07/2022 | WHEATBELT OFFICE & BUSINESS MACHINES (WOBM)          | CREATE298 - MONTHLY PHOTOCOPIER READING - 06/06/2022 - 04/07/2022   | 1         | 58.90      |        |
| EFT44314              | 14/07/2022 | WRIGHT EXPRESS AUSTRALIA PTY LTD (PUMA ENERGY)       | FUEL CHARGES FOR JUNE 2022  | 1         |            | 902.51 |
| INV JUNE 2            | 30/06/2022 | WRIGHT EXPRESS AUSTRALIA PTY LTD (PUMA ENERGY)       | FUEL CHARGES FOR JUNE 2022  | 1         | 902.51     |        |
| EFT44315              | 22/07/2022 | AFM PLASTIC PRODUCTS PTY LTD                         | 6MM CLEAR ACRYLIC DISPLAY CASE FOR NORTHAM ART PRIZE ARTWORK  | 1         |            | 258.50 |
| INV 000385505         | 07/2022    | AFM PLASTIC PRODUCTS PTY LTD                         | 6MM CLEAR ACRYLIC DISPLAY CASE FOR NORTHAM ART PRIZE ARTWORK  | 1         | 258.50     |        |
| EFT44316              | 22/07/2022 | AMPAC DEBT RECOVERY (WA) P/L                         | DEBT RECOVERY TO 8TH JULY 2022  | 1         |            | 38.50  |
| INV 85952             | 14/07/2022 | AMPAC DEBT RECOVERY (WA) P/L                         | DEBT RECOVERY TO 8TH JULY 2022  | 1         | 38.50      |        |
| EFT44317              | 22/07/2022 | APPLIED INDUSTRIAL TECHNOLOGIES T/A NORTHAM BEARINGS | BEARING FOR MOWER   | 1         |            | 5.86   |

Date: 01/08/2022  
Time: 9:17:37AM

Shire of Northam

USER: Louise Harris  
PAGE: 36 10

| Cheque /EFT No         | Date       | Name   | Invoice Description   | Bank Code | INV Amount | Amount     |
|------------------------|------------|--|---|-----------|------------|------------|
| INV 697401218/07/2022  |            | APPLIED INDUSTRIAL TECHNOLOGIES T/A NORTHAM BEARINGS | BEARING FOR MOWER   | 1         | 5.86       |            |
| EFT44318               | 22/07/2022 | ARLENE BYRNES  | REFUND PAYMENT MADE IN ERROR - RECEIVED 04/07/2022                          | 1         |            | 120.00     |
| INV CY 2107211/07/2022 |            | ARLENE BYRNES  | REFUND PAYMENT MADE IN ERROR - RECEIVED 04/07/2022                          | 1         | 120.00     |            |
| EFT44319               | 22/07/2022 | ASTROTOURISM WA PTY LTD                              | DARK SKY TOURISM - BILYA FESTIVAL - 12 AUGUST 2022                          | 1         |            | 3,300.00   |
| INV 1148               | 08/06/2022 | ASTROTOURISM WA PTY LTD                              | DARK SKY TOURISM - BILYA FESTIVAL - 12 AUGUST 2022                          | 1         | 3,300.00   |            |
| EFT44320               | 22/07/2022 | AUSTRALIAN SAFETY ENGINEERS                          | SERVICE BA UNITS  | 1         |            | 201.92     |
| INV 015564208/07/2022  |            | AUSTRALIAN SAFETY ENGINEERS                          | SERVICE BA UNITS  | 1         | 201.92     |            |
| EFT44321               | 22/07/2022 | AUSTRALIAN SERVICES UNION                            | PAYROLL DEDUCTIONS  | 1         |            | 129.50     |
| INV DEDUC19/07/2022    |            | AUSTRALIAN SERVICES UNION                            | PAYROLL DEDUCTIONS  |           | 129.50     |            |
| EFT44322               | 22/07/2022 | AUTOPRO NORTHAM                                      | GLOBES FOR PN1213   | 1         |            | 5.17       |
| INV 100201330/06/2022  |            | AUTOPRO NORTHAM                                      | GLOBES FOR PN1213   | 1         | 5.17       |            |
| EFT44323               | 22/07/2022 | AVON WASTE   | C.202122-04 MANAGEMENT OF OLD QUARRY ROAD LANDFILL FACILITY - JUNE 2022     | 1         |            | 122,217.55 |
| INV 50096              | 06/05/2022 | AVON WASTE   | DOMESTIC / COMMERCIAL RUBBISH COLLECTION - PERIOD ENDING 6TH MAY 2022       | 1         | 37,686.58  |            |
| INV 50645              | 17/06/2022 | AVON WASTE   | DOMESTIC / COMMERCIAL RUBBISH COLLECTION - PERIOD ENDING 17TH JUNE 2022     | 1         | 37,410.27  |            |
| INV 000506417/06/2022  |            | AVON WASTE   | C.202122-04 MANAGEMENT OF OLD QUARRY ROAD LANDFILL FACILITY - JUNE 2022     | 1         | 47,120.70  |            |
| EFT44324               | 22/07/2022 | BENARA NURSERIES                                     | WESTRINGEA / ANGOZANTHOS / SEDUM  | 1         |            | 1,950.76   |
| INV 378790             | 18/07/2022 | BENARA NURSERIES                                     | WESTRINGEA / ANGOZANTHOS / SEDUM  | 1         | 1,950.76   |            |
| EFT44325               | 22/07/2022 | BGC (AUSTRALIA) PTY LTD T/A BGC QUARRIES             | DELIVER LOAD TO SHIRE OF NORTHAM OLD QUARRY ROAD WASTE MANAGEMENT FACILITY. | 1         |            | 1,419.01   |

Ordinary Council Meeting Agenda  
17 August 2022



Date: 01/08/2022  
Time: 9:17:37AM

Shire of Northam

USER: Louise Harris  
PAGE: 37 13

| Cheque /EFT No        | Date       | Name                                     | Invoice Description   | Bank Code | INV Amount | Amount   |
|-----------------------|------------|--|---|-----------|------------|----------|
| INV IQ3396010/07/2022 |            | BGC (AUSTRALIA) PTY LTD T/A BGC QUARRIES | 7MM BLUE METAL  | 1         | 586.89     |          |
| INV IQ3395910/07/2022 |            | BGC (AUSTRALIA) PTY LTD T/A BGC QUARRIES | DELIVER LOAD TO SHIRE OF NORTHAM OLD QUARRY ROAD WASTE MANAGEMENT FACILITY.   | 1         | 832.12     |          |
| EFT44326              | 22/07/2022 | BUCCI HOLDINGS PTY LTD T-AS VISIMAX      | MICROCHIP READER - DATAMARS, COMPACT MAX, FDXB & A  | 1         |            | 416.48   |
| INV INV-04522/06/2022 |            | BUCCI HOLDINGS PTY LTD T-AS VISIMAX      | MICROCHIP READER - DATAMARS, COMPACT MAX, FDXB & A  | 1         | 416.48     |          |
| EFT44327              | 22/07/2022 | BUNNINGS BUILDING SUPPLIES P/L           | 16 X THRYPTOMENE PINK LACE  | 1         |            | 580.54   |
| INV 2182/0007/07/2022 |            | BUNNINGS BUILDING SUPPLIES P/L           | 19MM POLY WITH FITTINGS   | 1         | 99.57      |          |
| INV 2182/0012/07/2022 |            | BUNNINGS BUILDING SUPPLIES P/L           | TRAILER MESH / SIGN / LUBRICANT / HERBICIDE   | 1         | 176.83     |          |
| INV 2182/0012/07/2022 |            | BUNNINGS BUILDING SUPPLIES P/L           | 16 X THRYPTOMENE PINK LACE  | 1         | 262.24     |          |
| INV 2182/0013/07/2022 |            | BUNNINGS BUILDING SUPPLIES P/L           | POLY PIPE AND FITTINGS  | 1         | 41.90      |          |
| EFT44328              | 22/07/2022 | CADD'S FASHIONS                          | WORKBOOT ALLOWANCE - SONYA LINDNER  | 1         |            | 170.00   |
| INV 22-000013/07/2022 |            | CADD'S FASHIONS                          | WORKBOOT ALLOWANCE - SONYA LINDNER  | 1         | 170.00     |          |
| EFT44329              | 22/07/2022 | CADSULT IDS - FISCUS CONTRACTING T/AS    | RETICULATION CONCEPT DESIGN BROOME TERRACE AS PER QUOTE   | 1         |            | 1,287.00 |
| INV INV-18430/06/2022 |            | CADSULT IDS - FISCUS CONTRACTING T/AS    | RETICULATION CONCEPT DESIGN BROOME TERRACE AS PER QUOTE   | 1         | 1,287.00   |          |
| EFT44330              | 22/07/2022 | CENTRAL MOBILE MECHANICAL REPAIRS        | 5X ROLLER SHIFTS  | 1         |            | 7,408.50 |
| INV 000040730/06/2022 |            | CENTRAL MOBILE MECHANICAL REPAIRS        | 5X ROLLER SHIFTS  | 1         | 3,283.50   |          |
| INV 000040730/06/2022 |            | CENTRAL MOBILE MECHANICAL REPAIRS        | PICK UP 2X ROLLERS FROM FRENCHES ROAD AND DROP OFF AT HABGOOD ROOD  | 1         | 709.50     |          |
| INV 000040713/07/2022 |            | CENTRAL MOBILE MECHANICAL REPAIRS        | PICK UP STEEL DRUM ROLLER FROM BELMUGGIN RD AND DROP OFF AT HENRY ST OVAL 07/07/2022 / PICK UP MULTI ROLLER FROM BELMUGGIN RD AND DROP OFF AT HENRY ST OVAL 07/07/2022 / PICK UP MULTI ROLLER FROM CNR HITCHCOCK & CLYDESDALE RDS AND DROP OFF AT CNR SCOTT AND SOUTHERN BROOK RDS 11/07/2022 | 1         | 2,128.50   |          |

Ordinary Council Meeting Agenda  
17 August 2022



Date: 01/08/2022  
Time: 9:17:37AM

Shire of Northam

USER: Louise Harris  
PAGE: 38 10

| Cheque /EFT No         | Date       | Name                                | Invoice Description   | Bank Code | INV Amount | Amount   |
|------------------------|------------|-------------------------------------|---|-----------|------------|----------|
| INV 000040814/07/2022  |            | CENTRAL MOBILE MECHANICAL REPAIRS   | PICK UP STEEL DRUM ROLLER FROM HENRY ST AND DROP OFF AT ENRIGHT PARK  | 1         | 577.50     |          |
| INV 000040814/07/2022  |            | CENTRAL MOBILE MECHANICAL REPAIRS   | PICK UP STEEL DRUM ROLLER FROM ENRIGHT PARK AND DROP OFF AT EADINE RD (JUST BEFORE SMITH RD)  | 1         | 709.50     |          |
| EFT44331               | 22/07/2022 | CHADSON ENGINEERING                 | 3 X SERVICING PALINTEST INCLUDING DELIVERY  | 1         |            | 1,244.10 |
| INV A00984             | 07/07/2022 | CHADSON ENGINEERING                 | 3 X SERVICING PALINTEST INCLUDING DELIVERY  | 1         | 951.50     |          |
| INV A00984             | 07/07/2022 | CHADSON ENGINEERING                 | PALINTEST KIT, SERIAL NO. PT709P0814370 - SERVICE AND CALIBRATION (FREIGHT INC)   | 1         | 292.60     |          |
| EFT44332               | 22/07/2022 | CHILD SUPPORT AGENCY                | PAYROLL DEDUCTIONS  | 1         |            | 429.54   |
| INV DEDUC19/07/2022    |            | CHILD SUPPORT AGENCY                | PAYROLL DEDUCTIONS  |           | 429.54     |          |
| EFT44333               | 22/07/2022 | CLEANAWAY DANIEL S SERVICES PTY LTD | BERNARD PARK PUBLIC TOILETS X 3 SHARPS DISPOSAL SERVICE 27/06/2022  | 1         |            | 618.82   |
| INV 209180830/06/2022  |            | CLEANAWAY DANIEL S SERVICES PTY LTD | BAKERS HILL HOOPER PARK PUBLIC TOILETS X 2 SHARPS DISPOSAL SERVICE 09/06/2022 & 27/06/2022  | 1         | 103.14     |          |
| INV 209180930/06/2022  |            | CLEANAWAY DANIELS SERVICES PTY LTD  | BERNARD PARK PUBLIC TOILETS X 3 SHARPS DISPOSAL SERVICE 27/06/2022  | 1         | 206.27     |          |
| INV 209181030/06/2022  |            | CLEANAWAY DANIEL S SERVICES PTY LTD | APEX PARK PUBLIC TOILETS X 4 SHARPS DISPOSAL SERVICE 9/6/22 & 27/6/22   | 1         | 206.27     |          |
| INV 209181130/06/2022  |            | CLEANAWAY DANIEL S SERVICES PTY LTD | WUNDOWIE PUBLIC TOILETS X 2 SHARPS DISPOSAL SERVICE 09/06/2022  | 1         | 103.14     |          |
| EFT44334               | 22/07/2022 | COLES SUPERMARKETS PTY LTD          | COLES PURCHASES - JUNE 2022 - KILLARA / REC CENTRE / DEPOT / LIBRARY / COMMUNITY DEVELOPMENT / ADMIN / COUNCILLOR MEETINGS / DEVELOPMENT SERVICES | 1         |            | 2,915.42 |
| INV 180                | 30/06/2022 | COLES SUPERMARKETS PTY LTD          | COLES PURCHASES - JUNE 2022 - KILLARA / REC CENTRE / DEPOT / LIBRARY / COMMUNITY DEVELOPMENT / ADMIN / COUNCILLOR MEETINGS / DEVELOPMENT SERVICES | 1         | 2,915.42   |          |
| EFT44335               | 22/07/2022 | COMBINED TYRES PTY LTD              | FN1806 - 2 x COASTER BUS TYRES. 17701851 - 215/70R17.5 YOKOHAMA, INCLUDING DISPOSAL   | 1         |            | 1,094.50 |
| INV INV -24513/07/2022 |            | COMBINED TYRES PTY LTD              | FN1806 - 2 x COASTER BUS TYRES. 17701851 - 215/70R17.5 YOKOHAMA, INCLUDING DISPOSAL   | 1         | 1,094.50   |          |



Ordinary Council Meeting Agenda  
17 August 2022

Date: 01/08/2022  
Time: 9:17:37AM

Shire of Northam

USER: Louise Harris  
PAGE: 39 13

| Cheque /EFT No       | Date       | Name   | Invoice Description   | Bank Code | INV Amount | Amount   |
|----------------------|------------|--|---|-----------|------------|----------|
| EFT44336             | 22/07/2022 | COUNTRY COPIERS NORTHAM                      | DYMO LABEL WRITERS  | 1         |            | 718.55   |
| INV 45034            | 31/05/2022 | COUNTRY COPIERS NORTHAM                      | DYMO LABEL WRITERS  | 1         | 336.65     |          |
| INV 45034            | 31/05/2022 | COUNTRY COPIERS NORTHAM                      | STICKERS FOR NATIVE PLANT GIVEAWAY  | 1         | 74.75      |          |
| INV 45034            | 31/05/2022 | COUNTRY COPIERS NORTHAM                      | INK CARTRIDGES COLOUR (C,M,Y) VALUE PACK @ \$109.45 EACH X 2 = \$218.90                         | 1         | 218.90     |          |
| INV 45034            | 31/05/2022 | COUNTRY COPIERS NORTHAM                      | USB   | 1         | 15.80      |          |
| INV 45034            | 31/05/2022 | COUNTRY COPIERS NORTHAM                      | POSTER CARDS  | 1         | 10.65      |          |
| INV 45034            | 31/05/2022 | COUNTRY COPIERS NORTHAM                      | 89X62 AVERY LABELS  | 1         | 43.20      |          |
| INV 45034            | 31/05/2022 | COUNTRY COPIERS NORTHAM                      | POSTER CARDS  | 1         | 18.60      |          |
| EFT44337             | 22/07/2022 | COUNTRYWIDE GROUP                            | T435 CHAINSAW REPAIRS   | 1         |            | 978.49   |
| INV ACC00104/07/2022 |            | COUNTRYWIDE GROUP                            | ACCELERATOR CABLE FOR A ROTARY HOE  | 1         | 33.63      |          |
| INV ACC00113/07/2022 |            | COUNTRYWIDE GROUP                            | T435 CHAINSAW REPAIRS   | 1         | 30.00      |          |
| INV ACC00113/07/2022 |            | COUNTRYWIDE GROUP                            | T435 CHAINSAW REPAIRS   | 1         | 77.99      |          |
| INV ACC00113/07/2022 |            | COUNTRYWIDE GROUP                            | T435 CHAINSAW REPAIRS   | 1         | 209.99     |          |
| INV ACC00113/07/2022 |            | COUNTRYWIDE GROUP                            | T435 CHAINSAW REPAIRS   | 1         | 117.80     |          |
| INV ACC00113/07/2022 |            | COUNTRYWIDE GROUP                            | T435 CHAINSAW REPAIRS   | 1         | 359.99     |          |
| INV ACC00114/07/2022 |            | COUNTRYWIDE GROUP                            | PN1903 -HUSQVANA MOWER REPAIRS  | 1         | 149.09     |          |
| EFT44338             | 22/07/2022 | DCM CARPENTRY & MAINTENANCE                  | VISITORS CENTRE. REPLACE DAMAGED DECKING BOARD NEAR CAFE.                                       | 1         |            | 328.90   |
| INV 1400             | 21/06/2022 | DCM CARPENTRY & MAINTENANCE                  | VISITORS CENTRE. REPLACE DAMAGED DECKING BOARD NEAR CAFE.                                       | 1         | 328.90     |          |
| EFT44339             | 22/07/2022 | DEPARTMENT OF WATER & ENVIRONMENT REGULATION | ANNUAL DWER LICENCE FEE FOR 2022 2023 - OLD QUARRY ROAD WASTE FACILITY - LICENCE L6977/1997/10. | 1         |            | 6,952.00 |
| INV W-L697           | 12/07/2022 | DEPARTMENT OF WATER & ENVIRONMENT REGULATION | ANNUAL DWER LICENCE FEE FOR 2022 2023 - OLD QUARRY ROAD WASTE FACILITY - LICENCE L6977/1997/10. | 1         | 6,952.00   |          |

Ordinary Council Meeting Agenda  
17 August 2022



Date: 01/08/2022  
Time: 9:17:37AM

Shire of Northam

USER: Louise Harris  
PAGE: 40 10

| Cheque /EFT No | Date         | Name                                   | Invoice Description   | Bank Code | INV Amount | Amount   |
|----------------|--------------|--|---|-----------|------------|----------|
| EFT44340       | 22/07/2022   | DIANA MARIE SPENCER                    | RATES CREDIT REFUND FOR ASSESSMENT A10935 70 FORREST STREET NORTHAM WA 6401                                   | 1         |            | 200.00   |
| INV A10935     | 22/07/2022   | DIANA MARIE SPENCER                    | RATES CREDIT REFUND FOR ASSESSMENT A10935 70 FORREST STREET NORTHAM WA 6401                                   |           | 200.00     |          |
| EFT44341       | 22/07/2022   | DMC CLEANING                           | CLEANING OF SHIRE OF NORTHAM FACILITIES - C202021-05 - 1/6/2022 - 30/6/2022                                   | 1         |            | 8,694.41 |
| INV SON20930   | 06/2022      | DMC CLEANING                           | CLEANING OF SHIRE OF NORTHAM FACILITIES - C202021-05 - 1/6/2022 - 30/6/2022                                   | 1         | 8,694.41   |          |
| EFT44342       | 22/07/2022   | DOREEN STACK                           | RETURN BOND FOR PAMENT ON BOOKING 5284  | 1         |            | 100.00   |
| INV 13274      | 13/07/2022   | DOREEN STACK                           | RETURN BOND FOR PAMENT ON BOOKING 5284  | 1         | 100.00     |          |
| EFT44343       | 22/07/2022   | EASIFLEET                              | PAYROLL DEDUCTIONS  | 1         |            | 1,853.35 |
| INV DEDUC      | 19/07/2022   | EASIFLEET                              | PAYROLL DEDUCTIONS  |           | 1,054.26   |          |
| INV DEDUC      | 19/07/2022   | EASIFLEET                              | PAYROLL DEDUCTIONS  |           | 799.09     |          |
| EFT44344       | 22/07/2022   | ECOMIST SWAN                           | 3 X SANITARY (ECOMIST) BINS YEARLY SERVICE / 5 X FRAGRANCE YEARLY SERVICE / 1 X INSECT CONTROL YEARLY SERVICE | 1         |            | 1,663.31 |
| INV 00061      | 1808/07/2022 | ECOMIST SWAN                           | 3 X SANITARY (ECOMIST) BINS YEARLY SERVICE / 5 X FRAGRANCE YEARLY SERVICE / 1 X INSECT CONTROL YEARLY SERVICE | 1         | 1,663.31   |          |
| EFT44345       | 22/07/2022   | GHD PTY LTD                            | C.202122-10 SHIRE OF NORTHAM REUSE WATER SCHEME UPGRADE   | 1         |            | 3,680.60 |
| INV 112-01207  | 07/2022      | GHD PTY LTD                            | C.202122-10 SHIRE OF NORTHAM REUSE WATER SCHEME UPGRADE   | 1         | 3,680.60   |          |
| EFT44346       | 22/07/2022   | GOODYEAR & DUNLOP TYRES (AUST) PTY LTD | FN1602 - MITSU UTE, SUPPLY AND FIT 4 TYRES INCLUDING DISPOSAL. AS PER QUOTE U524107540                        | 1         |            | 1,375.49 |
| INV 641265808  | 07/2022      | GOODYEAR & DUNLOP TYRES (AUST) PTY LTD | FN1502 - REPLACE ROLLER TYRE ON SITE, HITCHCOCK RD  | 1         | 321.55     |          |
| INV 641266614  | 07/2022      | GOODYEAR & DUNLOP TYRES (AUST) PTY LTD | FN1705 - MOWER PUNCTURE REPAIR  | 1         | 53.72      |          |
| INV 641266514  | 07/2022      | GOODYEAR & DUNLOP TYRES (AUST) PTY LTD | FN1602 - MITSU UTE, SUPPLY AND FIT 4 TYRES INCLUDING DISPOSAL. AS PER QUOTE U524107540                        | 1         | 758.54     |          |

Ordinary Council Meeting Agenda  
17 August 2022

Date: 01/08/2022  
Time: 9:17:37AM

Shire of Northam

USER: Louise Harris  
PAGE: 41 13

| Cheque /EFT No        | Date       | Name                                   | Invoice Description   | Bank Code | INV Amount | Amount    |
|-----------------------|------------|--|---|-----------|------------|-----------|
| INV 641267018/07/2022 |            | GOODYEAR & DUNLOP TYRES (AUST) PTY LTD | FN1802- REGO 1TTO41. REPLACE WOODCHIPPER TYRE   | 1         | 241.68     |           |
| EFT44347              | 22/07/2022 | GRAFTON ELECTRICS                      | AERODROME. REPAIR/REPLACE RUNWAY LIGHT 44 THAT HAS BEEN DAMAGED.  | 1         |            | 110.00    |
| INV 8768              | 23/06/2022 | GRAFTON ELECTRICS                      | AERODROME. REPAIR/REPLACE RUNWAY LIGHT 44 THAT HAS BEEN DAMAGED.  | 1         | 110.00     |           |
| EFT44348              | 22/07/2022 | HER MAJESTY BALLROOM                   | REIMBURSE BOND FO BOOKING 5281  | 1         |            | 100.00    |
| INV 13278             | 19/07/2022 | HER MAJESTY BALLROOM                   | REIMBURSE BOND FO BOOKING 5281  | 1         | 100.00     |           |
| EFT44349              | 22/07/2022 | IRRIGATION AUSTRALIA LTD               | MEMBERSHIP FEE FOR PERIOD 01/07/2022 TO 30/06/2023  | 1         |            | 780.00    |
| INV 307516212/07/2022 |            | IRRIGATION AUSTRALIA LTD               | MEMBERSHIP FEE FOR PERIOD 01/07/2022 TO 30/06/2023  | 1         | 780.00     |           |
| EFT44350              | 22/07/2022 | IW PROJECTS ATF THE CARMEL TRUST       | NORTHAM OLD LANDFILL CAPPING INVESTIGATION AND REPORTING AS PER QUOTE PROVIDED.                                       | 1         |            | 11,440.00 |
| INV 1451              | 30/06/2022 | IW PROJECTS ATF THE CARMEL TRUST       | NORTHAM OLD LANDFILL CAPPING INVESTIGATION AND REPORTING AS PER QUOTE PROVIDED.                                       | 1         | 11,440.00  |           |
| EFT44351              | 22/07/2022 | IXOM OPERATIONS PTY LTD                | CLORINE MONTHLY SERVICE FEE FOR JUNE 2022   | 1         |            | 505.89    |
| INV 654374730/06/2022 |            | IXOM OPERATIONS PTY LTD                | CLORINE MONTHLY SERVICE FEE FOR JUNE 2022   | 1         | 337.26     |           |
| INV 654374730/06/2022 |            | IXOM OPERATIONS PTY LTD                | CLORINE MONTHLY SERVICE FEE FOR NORTHAM AQUATIC FACILITY - JUNE 2022  | 1         | 168.63     |           |
| EFT44352              | 22/07/2022 | J & A BUILDING PTY LTD                 | PROGRESS CLAIM 7 - COMPLETION OF CONCRETE WORKS - FOOTING EXCAVATION / STEEL REINFORCING / FOTTING AND CONCRETE POURS | 1         |            | 42,177.08 |
| INV 000032925/05/2022 |            | J & A BUILDING PTY LTD                 | PROGRESS CLAIM 7 - COMPLETION OF CONCRETE WORKS - FOOTING EXCAVATION / STEEL REINFORCING / FOTTING AND CONCRETE POURS | 1         | 41,157.08  |           |
| INV T1610             | 22/07/2022 | J & A BUILDING PTY LTD                 | REFUND OF INFRASTRUCTURE BOND - NO DAMAGE   | 1         | 1,020.00   |           |
| EFT44353              | 22/07/2022 | JULIE WYNNE                            | FACEPAINTING DONE BY JASMINE WYNNE FOR NAIDOC CELEBRATIONS @ BILYA KOORT BOODJA 07-07-2022                            | 1         |            | 200.00    |

Ordinary Council Meeting Agenda  
17 August 2022



Date: 01/08/2022  
Time: 9:17:37AM

Shire of Northam

USER: Louise Harris  
PAGE: 42 10

| Cheque /EFT No         | Date       | Name  | Invoice Description  | Bank Code | INV Amount | Amount   |
|------------------------|------------|---|--|-----------|------------|----------|
| INV 13                 | 07/07/2022 | JULIE WYNNE                                 | FACEPAINTING DONE BY JASMINE WYNNE FOR NAIDOC CELEBRATIONS @ BILYA KOORT BOODJA 07-07-2022           | 1         | 200.00     |          |
| EFT44354               | 22/07/2022 | KLEENWEST DISTRIBUTORS                      | CHEMICALS, MEDIUM GLOVES, PLASTIC CONTAINERS AND TOILET PAPER FOR KILLARA                            | 1         |            | 398.59   |
| INV 000704706/07/2022  |            | KLEENWEST DISTRIBUTORS                      | CHEMICALS, MEDIUM GLOVES, PLASTIC CONTAINERS AND TOILET PAPER FOR KILLARA                            | 1         | 398.59     |          |
| EFT44355               | 22/07/2022 | LOCAL GOVERNMENT PROFESSIONALS AUSTRALIA WA | LOCAL GOVERNMENT PROFESSIONALS MEMBERSHIP RENEWAL FOR JASON WHITAKER                                 | 1         |            | 531.00   |
| INV 27015 01/07/2022   |            | LOCAL GOVERNMENT PROFESSIONALS AUSTRALIA WA | LOCAL GOVERNMENT PROFESSIONALS MEMBERSHIP RENEWAL FOR JASON WHITAKER                                 | 1         | 531.00     |          |
| EFT44356               | 22/07/2022 | LUCY'S TEAROOMS                             | CATERING - ORDINARY COUNCIL MEETING - 16/02/2022 / CATERING - AVON MIDLAND ZONE MEETING - 18/02/2022 | 1         |            | 1,626.50 |
| INV 2675               | 02/03/2022 | LUCY'S TEAROOMS                             | CATERING - ORDINARY COUNCIL MEETING - 16/02/2022 / CATERING - AVON MIDLAND ZONE MEETING - 18/02/2022 | 1         | 945.00     |          |
| INV 2679               | 02/03/2022 | LUCY'S TEAROOMS                             | CATERING - REGIONAL ROAD GROUP MEETING 28/02/2022  | 1         | 212.50     |          |
| INV 2658               | 02/03/2022 | LUCY'S TEAROOMS                             | CATERING - ORDINARY COUNCIL MEETING 19/01/2022   | 1         | 334.00     |          |
| INV 2689               | 02/05/2022 | LUCY'S TEAROOMS                             | CATERING FOR CITIZENSHIP CEREMONY ON 25 MARCH 2022   | 1         | 135.00     |          |
| EFT44357               | 22/07/2022 | MAD DOG PROMOTIONS                          | TITAN TORCH KEY RING / HOUSE PVC KEYTAG K15 / CAR/VAN PVC KEYTAG K13                                 | 1         |            | 3,509.00 |
| INV INV -40206/07/2022 |            | MAD DOG PROMOTIONS                          | TITAN TORCH KEY RING / HOUSE PVC KEYTAG K15 / CAR/VAN PVC KEYTAG K13                                 | 1         | 3,509.00   |          |
| EFT44358               | 22/07/2022 | MENTAL MEDIA PTY LTD                        | GUIDE ID (PODCATCHER) SUBSCRIPTION SERVICE JULY - SEPTEMBER 2022                                     | 1         |            | 1,938.42 |
| INV 1321               | 05/07/2022 | MENTAL MEDIA PTY LTD                        | GUIDE ID (PODCATCHER) SUBSCRIPTION SERVICE JULY - SEPTEMBER 2022                                     | 1         | 1,938.42   |          |
| EFT44359               | 22/07/2022 | MIRANDA CHORLTON                            | RETURN OF BOND FOR HIRE OF WUNDOWIE HALL #5178   | 1         |            | 100.00   |
| INV 5178               | 14/07/2022 | MIRANDA CHORLTON                            | RETURN OF BOND FOR HIRE OF WUNDOWIE HALL #5178   | 1         | 100.00     |          |
| EFT44360               | 22/07/2022 | NORTHAM BETTA HOME LIVING                   | 3X HELLER HEATERS  | 1         |            | 209.85   |

Date: 01/08/2022  
Time: 9:17:37AM

Shire of Northam

USER: Louise Harris  
PAGE: 43 13

| Cheque /EFT No        | Date       | Name                              | Invoice Description   | Bank Code | INV Amount | Amount    |
|-----------------------|------------|-----------------------------------|---|-----------|------------|-----------|
| INV 200100412/07/2022 |            | NORTHAM BETTA HOME LIVING         | 3X HELLER HEATERS   | 1         | 209.85     |           |
| EFT44361              | 22/07/2022 | NORTHAM FEED & HIRE               | SWAN FOOD & OTHER MISCELLANEOUS ITEMS - JULY 2022   | 1         |            | 24.50     |
| INV 000043212/07/2022 |            | NORTHAM FEED & HIRE               | SWAN FOOD & OTHER MISCELLANEOUS ITEMS - JULY 2022   | 1         | 24.50      |           |
| EFT44362              | 22/07/2022 | PERTH ENERGY PTY LTD              | ELECTRICITY CHARGES FOR ACCOUNT 601148 - 182 FITZGERALD ST, NORTHAM (POP UP SHOP) - STATEMENT NO: 2286500   | 1         |            | 189.90    |
| INV 228650015/07/2022 |            | PERTH ENERGY PTY LTD              | ELECTRICITY CHARGES FOR ACCOUNT 601148 - 182 FITZGERALD ST, NORTHAM (POP UP SHOP) - STATEMENT NO: 2286500   | 1         | 189.90     |           |
| EFT44363              | 22/07/2022 | POOL AND PUMP SERVICE AND REPAIRS | CHLORINE GAS TREATMENT SYSTEM -<br>- INSPECTION,<br>- REMOVE FAULTY COMPONENTS,<br>- PROVIDE TECHNICAL SERVICE REQUIREMENTS FOR (RFQ),<br>- PROVIDE QUOTATION ON REPAIR OR REPAACEMENT OF CHLORINE GAS COMPONENT FAULTS | 1         |            | 1,069.20  |
| INV PPS006            | 12/07/2022 | POOL AND PUMP SERVICE AND REPAIRS | CHLORINE GAS TREATMENT SYSTEM -<br>- INSPECTION,<br>- REMOVE FAULTY COMPONENTS,<br>- PROVIDE TECHNICAL SERVICE REQUIREMENTS FOR (RFQ),<br>- PROVIDE QUOTATION ON REPAIR OR REPAACEMENT OF CHLORINE GAS COMPONENT FAULTS | 1         | 1,069.20   |           |
| EFT44364              | 22/07/2022 | SAFETY BARRIERS WA PTY LTD        | C.202122-12 MITCHELL AVE GUARD RAIL INSALLATION AND ASSOC WORKS.  | 1         |            | 87,318.00 |
| INV 000058930/06/2022 |            | SAFETY BARRIERS WA PTY LTD        | C.202122-12 MITCHELL AVE GUARD RAIL INSALLATION AND ASSOC WORKS.  | 1         | 87,318.00  |           |
| EFT44365              | 22/07/2022 | SIGMA CHEMICALS                   | ELECTROLYTE GEL / FREIGHT   | 1         |            | 182.60    |
| INV 157960/25/05/2022 |            | SIGMA CHEMICALS                   | ELECTROLYTE GEL / FREIGHT   | 1         | 155.10     |           |
| INV 158262/31/05/2022 |            | SIGMA CHEMICALS                   | DELIVERY FROM SIGMA   | 1         | 27.50      |           |

Date: 01/08/2022  
Time: 9:17:37AM

Shire of Northam

USER: Louise Harris  
PAGE: 44 10

| Cheque /EFT No        | Date       | Name   | Invoice Description  | Bank Code | INV Amount | Amount   |
|-----------------------|------------|--|--|-----------|------------|----------|
| EFT44366              | 22/07/2022 | SIMON PAYNE T/A ROOF ACCESS WA               | ROOF ACECESS AUDIT AND REPORT - 2022 - ADMIN / AQUATIC / BAKER HILL REC/ BKB / OLD PO / NORTH REC CENTRE / OLD TOWN HALL   | 1         |            | 2,640.00 |
| INV 220516            | 07/07/2022 | SIMON PAYNE T/A ROOF ACCESS WA               | ROOF ACECESS AUDIT AND REPORT - 2022 - ADMIN / AQUATIC / BAKER HILL REC/ BKB / OLD PO / NORTH REC CENTRE / OLD TOWN HALL   | 1         | 2,640.00   |          |
| EFT44367              | 22/07/2022 | SNAP PRINTING NORTHBRIDGE T/AS ML SN PTY LTD | 1000x A5 FRIDGE MAGNETS  | 1         |            | 2,379.99 |
| INV F040-3329/06/2022 |            | SNAP PRINTING NORTHBRIDGE T/AS ML SN PTY LTD | 1000x A5 FRIDGE MAGNETS  | 1         | 1,638.11   |          |
| INV F040-3329/06/2022 |            | SNAP PRINTING NORTHBRIDGE T/AS ML SN PTY LTD | 500x A6 FRIDGE MAGNETS (250 X TWO KINDS)   | 1         | 741.88     |          |
| EFT44368              | 22/07/2022 | SPECIALISED TREE SERVICE                     | 150 YILGARN AVE NORTHAM. ALONG FENCE LINE OF NORTHAM CARAVAN PARK. SAFELY DISMANTLE TO GROUND LEVEL 4 LARGE AND 1 SMALL DEAD TREE. ALL MATERIAL REMOVED FROM SITE. SAFELY COMPLETE MAJOR DEAD WOOD REMOVAL FROM TWIN TRUNK TREE, ALL MATERIAL REMOVED FROM SITE. AS PER QUOTE 1038 | 1         |            | 3,135.00 |
| INV 3892              | 14/07/2022 | SPECIALISED TREE SERVICE                     | 150 YILGARN AVE NORTHAM. ALONG FENCE LINE OF NORTHAM CARAVAN PARK. SAFELY DISMANTLE TO GROUND LEVEL 4 LARGE AND 1 SMALL DEAD TREE. ALL MATERIAL REMOVED FROM SITE. SAFELY COMPLETE MAJOR DEAD WOOD REMOVAL FROM TWIN TRUNK TREE, ALL MATERIAL REMOVED FROM SITE. AS PER QUOTE 1038 | 1         | 3,135.00   |          |
| EFT44369              | 22/07/2022 | SPORTSPOWER NORTHAM H & H JOUBERT            | NETBALL BIBS   | 1         |            | 130.00   |
| INV 22-000011/07/2022 |            | SPORTSPOWER NORTHAM H & H JOUBERT            | NETBALL BIBS   | 1         | 130.00     |          |

Date: 01/08/2022  
Time: 9:17:37AM

Shire of Northam

USER: Louise Harris  
PAGE: 45 13

| Cheque /EFT No        | Date       | Name  | Invoice Description  | Bank Code | INV Amount | Amount   |
|-----------------------|------------|---|--|-----------|------------|----------|
| EFT44370              | 22/07/2022 | ST JOHN AMBULANCE AUSTRALIA (FIRST AID COURSE)  | FIRST AID - 2 DAY COURSE - 28/29 JUNE 2022<br>TIM EDMONDS, RUSSELL FITZGERALD, ROB SMITH,<br>COLIN MCPHERSON, JOSEPH WILLIAMS, SUSAN<br>CLAYTON, ERROL GARLETT, PHILLIP WHITE, CHARLES<br>CARR | 1         |            | 1,944.00 |
| INV FAINV029/06/2022  |            | ST JOHN AMBULANCE AUSTRALIA (FIRST AID COURSE)  | FIRST AID - 2 DAY COURSE - 28/29 JUNE 2022<br>TIM EDMONDS, RUSSELL FITZGERALD, ROB SMITH,<br>COLIN MCPHERSON, JOSEPH WILLIAMS, SUSAN<br>CLAYTON, ERROL GARLETT, PHILLIP WHITE, CHARLES<br>CARR | 1         | 1,944.00   |          |
| EFT44371              | 22/07/2022 | STALLION BUILDING CO PTY LTD T/A STALLION HOMES | FINAL RELEASE OF DEFECTS LIABILITY RETENTION FOR<br>C.202021-03 NORTHAM YOUTH PRECINCT PUBLIC TOILET<br>AMENITY  | 1         |            | 4,380.01 |
| INV T1578             | 22/07/2022 | STALLION BUILDING CO PTY LTD T/A STALLION HOMES | FINAL RELEASE OF DEFECTS LIABILITY RETENTION FOR<br>C.202021-03 NORTHAM YOUTH PRECINCT PUBLIC TOILET<br>AMENITY  | 1         | 4,380.01   |          |
| EFT44372              | 22/07/2022 | STATE LIBRARY OF WESTERN AUSTRALIA              | BETTER BEGINNINGS INVOICE 2022 -23   | 1         |            | 638.00   |
| INV RI0327513/07/2022 |            | STATE LIBRARY OF WESTERN AUSTRALIA              | BETTER BEGINNINGS INVOICE 2022 -23   | 1         | 638.00     |          |
| EFT44373              | 22/07/2022 | STEPHEN RALPH CRANE                             | REBATE FOR CROSSOVER CONSTRUCTION AT 8 ORCHID<br>TERRACE   | 1         |            | 1,000.00 |
| INV SP 010701/07/2022 |            | STEPHEN RALPH CRANE                             | REBATE FOR CROSSOVER CONSTRUCTION AT 8 ORCHID<br>TERRACE   | 1         | 1,000.00   |          |
| EFT44374              | 22/07/2022 | SYNERGY   | 335820940 CREATE 298 - 18/05/2022 to 14/06/2022  | 1         |            | 1,872.27 |
| INV 335820915/06/2022 |            | SYNERGY   | 335820940 CREATE 298 - 18/05/2022 to 14/06/2022  |           | 702.45     |          |
| INV 444997329/06/2022 |            | SYNERGY   | 444997300 WUNDOWIE LIBRARY & GARDENS - 29/04/2022<br>to 28/06/2022   |           | 453.06     |          |
| INV 353464104/07/2022 |            | SYNERGY   | 035346410 HOOVER PARK - 04/05/2022 to 30/06/2022   |           | 170.50     |          |
| INV 361333412/07/2022 |            | SYNERGY   | 361333420 AVON MALL - 12/05/2022 to 11/07/2022   |           | 546.26     |          |

Date: 01/08/2022  
Time: 9:17:37AM

Shire of Northam

USER: Louise Harris  
PAGE: 46 10

| Cheque /EFT No        | Date       | Name                      | Invoice Description  | Bank Code | INV Amount | Amount   |
|-----------------------|------------|---------------------------|--|-----------|------------|----------|
| EFT44375              | 22/07/2022 | TALIS CONSULTANTS PTY LTD | DAMAGE PICKUP OF ENTIRE NETWORK AND PROJECT MANAGEMENT AS PER CONTRACT C.202021-24. 1VEHICLE, 2PERSONS INCL MEALS AND ACCOMODATION. STORM EVENT 2-4MARCH2021 - AGRN962 - CONSULTANCE SERVICE FOR PERIOD ENDING 30 JUNE 2022                                | 1         |            | 5,486.25 |
| INV 25791             | 30/06/2022 | TALIS CONSULTANTS PTY LTD | DAMAGE PICKUP OF ENTIRE NETWORK AND PROJECT MANAGEMENT AS PER CONTRACT C.202021-24. 1VEHICLE, 2PERSONS INCL MEALS AND ACCOMODATION. STORM EVENT 2-4MARCH2021 - AGRN962 - CONSULTANCE SERVICE FOR PERIOD ENDING 30 JUNE 2022                                | 1         | 5,486.25   |          |
| EFT44376              | 22/07/2022 | TAMIKA VAN BEEK           | FOOD AND PARKING FOR LICENSING TRAINING / RECOUP FROM DEPT OF TRAINING   | 1         |            | 102.83   |
| INV CY 150715/07/2022 | 07/2022    | TAMIKA VAN BEEK           | FOOD AND PARKING FOR LICENSING TRAINING / RECOUP FROM DEPT OF TRAINING   | 1         | 102.83     |          |
| EFT44377              | 22/07/2022 | TELSTRA CORPORATION       | TELSTRA CHARGES - JUNE 2022 - ADMIN INTERNET   | 1         |            | 7,631.42 |
| INV 272600904/07/2022 | 07/2022    | TELSTRA CORPORATION       | TELSTRA CHARGES - JUNE 2022 - HARVEST BAN  | 1         | 1.25       |          |
| INV 272600810/07/2022 | 07/2022    | TELSTRA CORPORATION       | TELSTRA CHARGES - JUNE 2022 - COUNCILLOR IPADS / ADMIN / FINANCE / CESM / BUSHFIRES / RANGER SERVICES / CCTV / HEATH / KILLARA / LANDFILL / PLANNING / WUNDOWIE POOL / NORTHAM LIBRARY / BKB / ENGINEERING / BUILDING / VISITORS CENTRE / REC CENTRE / SES | 1         | 2,637.68   |          |
| INV 225839814/07/2022 | 07/2022    | TELSTRA CORPORATION       | TELSTRA CHARGES - JUNE 2022 - ADMIN INTERNET   | 1         | 4,071.10   |          |
| INV 272600916/07/2022 | 07/2022    | TELSTRA CORPORATION       | TELSTRA CHARGES - JUNE 2022 - ENGINEERING  | 1         | 4.41       |          |
| INV 902607517/07/2022 | 07/2022    | TELSTRA CORPORATION       | TELSTRA CHARGES - JUNE 2022 - ADMIN / FINANCE / INTERNET / HARVEST BAN / KILLARA INTERNET / LANDFILL / WUNDOWIE POOL / WUNDOWIE LIBRARY / CREATE 298 / ENGINEERING / LANDFILL INTERNET / REC CENTRE / CESM / BUSHFIRES                                     | 1         | 916.98     |          |
| EFT44378              | 22/07/2022 | TENNANT AUSTRALIA         | 3 X YEARLY SERVICE OF FLOOR SCRUBBERS. T1 AND T7 MACHINES - JUNE 2022  | 1         |            | 608.30   |



Ordinary Council Meeting Agenda  
17 August 2022



Date: 01/08/2022  
Time: 9:17:37AM

Shire of Northam

USER: Louise Harris  
PAGE: 47/13

| Cheque /EFT No | Date       | Name                         | Invoice Description   | Bank Code | INV Amount | Amount   |
|----------------|------------|------------------------------|---|-----------|------------|----------|
| INV 918838901  | 07/2022    | TENNANT AUSTRALIA            | 3 X YEARLY SERVICE OF FLOOR SCRUBBERS. T1 AND T7 MACHINES - JUNE 2022   | 1         | 608.30     |          |
| EFT44379       | 22/07/2022 | TOLL - IPEC PTY LTD T/AS     | TOLL FREIGHT CHARGES - JULY 2022 - REC CENTRE / DEPOT   | 1         |            | 69.53    |
| INV 0551-S303  | 07/2022    | TOLL - IPEC PTY LTD T/AS     | FREIGHT CHARGES - JULY 2022 - HEALTH  | 1         | 13.05      |          |
| INV 0552-S310  | 07/2022    | TOLL - IPEC PTY LTD T/AS     | TOLL FREIGHT CHARGES - JULY 2022 - REC CENTRE / HEALTH  | 1         | 28.07      |          |
| INV 0553-S317  | 07/2022    | TOLL - IPEC PTY LTD T/AS     | TOLL FREIGHT CHARGES - JULY 2022 - REC CENTRE / DEPOT   | 1         | 28.41      |          |
| EFT44380       | 22/07/2022 | TOTAL TRAINING GROUP PTY LTD | AHCPGD305 - OPERATION INSPECTION - LEVEL 2 ONLINE TRAINING FOR JASON LINDNER USI 2MF55K2QCH AND TIM EDMONDS USI NL T9Y8AMXC   | 1         |            | 3,100.00 |
| INV INV-C7706  | 07/2022    | TOTAL TRAINING GROUP PTY LTD | AHCPGD305 - OPERATION INSPECTION - LEVEL 2 ONLINE TRAINING FOR JASON LINDNER USI 2MF55K2QCH AND TIM EDMONDS USI NL T9Y8AMXC   | 1         | 3,100.00   |          |
| EFT44381       | 22/07/2022 | TPG TELECOM                  | TPG CHARGES - JUNE 2022 - ADMIN / FINANCE / BKB / CESM / CREATE 298 / ENGINEERING / HEALTH / BUILDING / KILLARA / LIBRARY NORTHAM / LIBRARY WUNDOWIE / PLANNING / RANGER SERVICES / REC CENTRE / VISITORS CENTRE / IT | 1         |            | 8,502.54 |
| INV 179306001  | 07/2022    | TPG TELECOM                  | TPG CHARGES - JUNE 2022 - CREATE 298 / SES / BFB  | 1         | 705.52     |          |
| INV 179332401  | 07/2022    | TPG TELECOM                  | TPG CHARGES - JUNE 2022 - ADMIN / FINANCE / BKB / CESM / CREATE 298 / ENGINEERING / HEALTH / BUILDING / KILLARA / LIBRARY NORTHAM / LIBRARY WUNDOWIE / PLANNING / RANGER SERVICES / REC CENTRE / VISITORS CENTRE / IT | 1         | 7,797.02   |          |
| EFT44382       | 22/07/2022 | VINCELEC                     | VISITORS CENTRE. REPLACE BROKEN FLOODLIGHT AT VIS CENTRE WITH CHERRY PICKER.  | 1         |            | 1,416.40 |
| INV IV1361     | 12/07/2022 | VINCELEC                     | VISITORS CENTRE. REPLACE BROKEN FLOODLIGHT AT VIS CENTRE WITH CHERRY PICKER.  | 1         | 1,416.40   |          |
| EFT44383       | 22/07/2022 | WA CONTRACT RANGER SERVICES  | C.201920-09 - MANAGMENT OF SHIRE OF NORTHAM DOG IMPOUND FACILITY 27/6/22 - 10/7/22  | 1         |            | 1,705.00 |
| INV 000040614  | 07/2022    | WA CONTRACT RANGER SERVICES  | CAT MANAGEMENT EXPENSES FOR JUNE 2022   | 1         | 200.00     |          |

Ordinary Council Meeting Agenda  
17 August 2022



Date: 01/08/2022  
Time: 9:17:37AM

Shire of Northam

USER: Louise Harris  
PAGE: 48 10

| Cheque /EFT No         | Date       | Name   | Invoice Description  | Bank Code | INV Amount | Amount     |
|------------------------|------------|--|--|-----------|------------|------------|
| INV 000040614/07/2022  |            | WA CONTRACT RANGER SERVICES                  | CAT MANAGEMENT EXPENCES FOR JUNE 2022  | 1         | 185.00     |            |
| INV 000040614/07/2022  |            | WA CONTRACT RANGER SERVICES                  | C.201920-09 - MANAGMENT OF SHIRE OF NORTHAM DOG IMPOUND FACILITY 27/6/22 - 10/7/22                           | 1         | 1,320.00   |            |
| EFT44384               | 22/07/2022 | WARRICKS NEWSAGENCY                          | STATIONERY SUPPLIES - ADMIN OFFICE   | 1         |            | 246.37     |
| INV SN00 0130/06/2022  |            | WARRICKS NEWSAGENCY                          | NEWSPAPERS FOR KILLARA - JUNE 2022   | 1         | 35.70      |            |
| INV 67108 11/07/2022   |            | WARRICKS NEWSAGENCY                          | STATIONERY SUPPLIES - ADMIN OFFICE   | 1         | 210.67     |            |
| EFT44385               | 22/07/2022 | WESTLINE PLUMBING & DRAINAGE PTY LTD         | NORTHAM DEPOT REDEVELOPMENT. INSTALL SEWER EXTENSION AS PER WATERCORP SPECIFICATIONS AND QUOTE Q10168-21REV3 | 1         |            | 76,156.31  |
| INV 1835               | 28/06/2022 | WESTLINE PLUMBING & DRAINAGE PTY LTD         | NORTHAM DEPOT REDEVELOPMENT. INSTALL SEWER EXTENSION AS PER WATERCORP SPECIFICATIONS AND QUOTE Q10168-21REV3 | 1         | 76,156.31  |            |
| EFT44386               | 22/07/2022 | WESTWIDE AUTO ELECTRICS AND AIR CONDITIONING | FN1906 - N10734 REMOVE INTERNAL AMBER BEACON LIGHTS  | 1         |            | 577.25     |
| INV INV -13730/06/2022 |            | WESTWIDE AUTO ELECTRICS AND AIR CONDITIONING | FN1906 - N10734 REMOVE INTERNAL AMBER BEACON LIGHTS  | 1         | 577.25     |            |
| EFT44387               | 22/07/2022 | WHEATBELT NATURAL RESOURCE MANAGEMENT        | MAINTENANCE OF NORTHAM CEMETERY AS PER C.201920-17, 21/06 - 30/6/2022  | 1         |            | 3,658.13   |
| INV 003013604/07/2022  |            | WHEATBELT NATURAL RESOURCE MANAGEMENT        | MAINTENANCE OF NORTHAM CEMETERY AS PER C.201920-17, 21/06 - 30/6/2022  | 1         | 3,658.13   |            |
| EFT44388               | 22/07/2022 | WOODLANDS DISTRIBUTORS PTY LTD               | EPI-OXO300 - DEGRADABLE SINGLE/GUSSETT BAG - 5 x CARTONS, 300 BAGS PER ROLL                                  | 1         |            | 632.50     |
| INV NTM1-014/07/2022   |            | WOODLANDS DISTRIBUTORS PTY LTD               | EPI-OXO300 - DEGRADABLE SINGLE/GUSSETT BAG - 5 x CARTONS, 300 BAGS PER ROLL                                  | 1         | 632.50     |            |
| EFT44389               | 26/07/2022 | WCP CIVIL PTY LTD                            | RESEALING WORK OF PARKER STREET / FORWARD ST, NORTHAM AS PER CONTRACT C.202122-05. - PROGRESS CLAIM 2        | 1         |            | 176,497.29 |
| INV 27204 30/06/2022   |            | WCP CIVIL PTY LTD                            | RESEALING WORK OF PARKER STREET / FORWARD ST, NORTHAM AS PER CONTRACT C.202122-05. - PROGRESS CLAIM 2        | 1         | 176,497.29 |            |
| EFT44390               | 28/07/2022 | ABBOTTS FORGE                                | REPAIR DECK OF JOHN DEERE MOWER  | 1         |            | 125.00     |

Ordinary Council Meeting Agenda  
17 August 2022

Date: 01/08/2022  
Time: 9:17:37AM

Shire of Northam

USER: Louise Harris  
PAGE: 49/13

| Cheque /EFT No | Date       | Name   | Invoice Description  | Bank Code | INV Amount | Amount    |
|----------------|------------|--|--|-----------|------------|-----------|
| INV 000052121  | 07/2022    | ABBOTTS FORGE  | REPAIR DECK OF JOHN DEERE MOWER  | 1         | 125.00     |           |
| EFT44391       | 28/07/2022 | ALEXANDRA LEE MACKENZIE  | REFUND OF INFRASTRUCTURE BOND - NO DAMAGE  | 1         |            | 1,000.00  |
| INV T1333      | 28/07/2022 | ALEXANDRA LEE MACKENZIE  | REFUND OF INFRASTRUCTURE BOND - NO DAMAGE  | 1         | 1,000.00   |           |
| EFT44392       | 28/07/2022 | AMPAC DEBT RECOVERY (WA) P/L   | DEBT RECOVERY FOR PERIOD ENDING 15 JULY 2022   | 1         |            | 989.87    |
| INV 85979      | 21/07/2022 | AMPAC DEBT RECOVERY (WA) P/L   | DEBT RECOVERY FOR PERIOD ENDING 15 JULY 2022   | 1         | 989.87     |           |
| EFT44393       | 28/07/2022 | ANDY'S PLUMBING SERVICE  | BAKERS HILL HOOPER PARK. REPAIR LEAKING TAP AT FRONT OF PARK.                        | 1         |            | 4,010.60  |
| INV A19351     | 19/07/2022 | ANDY'S PLUMBING SERVICE  | KILLARA. INVESTIGATE SEWER LEAK AND CLEAN UP.  | 1         | 258.50     |           |
| INV A19350     | 19/07/2022 | ANDY'S PLUMBING SERVICE  | KURINGAI VILLAGE UNIT 2. REPAIR BATHROOM DRAIN NOT DRAINING PROPERLY..               | 1         | 499.40     |           |
| INV A19349     | 19/07/2022 | ANDY'S PLUMBING SERVICE  | KILLARA RESPITE CARE. BOARD UP DOOR AFTER BREAK IN FRIDAY NIGHT.                     | 1         | 317.90     |           |
| INV A19352     | 19/07/2022 | ANDY'S PLUMBING SERVICE  | YOUTH PARK TOILETS. REPAIR BROKEN SINK IN ACCESSIBLE TOILETS AND UNBLOCK OTHER SINK. | 1         | 1,413.50   |           |
| INV A19353     | 25/07/2022 | ANDY'S PLUMBING SERVICE  | BAKERS HILL HOOPER PARK. REPAIR LEAKING TAP AT FRONT OF PARK.                        | 1         | 1,521.30   |           |
| EFT44394       | 28/07/2022 | APPLIED INDUSTRIAL TECHNOLOGIES T/A NORTHAM BEARINGS                   | SILVER GRAFE A/SEIZE LB8150 LOCTITE  | 1         |            | 47.60     |
| INV 697804225  | 07/2022    | APPLIED INDUSTRIAL TECHNOLOGIES T/A NORTHAM BEARINGS                   | SILVER GRAFE A/SEIZE LB8150 LOCTITE  | 1         | 47.60      |           |
| EFT44395       | 28/07/2022 | AUSTRALASIAN PERFORMING RIGHT ASSOCIATION LTD T/A S ONEMUSIC AUSTRALIA | MUSIC FOR COUNCIL S - RURAL  | 1         |            | 1,586.68  |
| INV 262528     | 02/07/2022 | AUSTRALASIAN PERFORMING RIGHT ASSOCIATION LTD T/A S ONEMUSIC AUSTRALIA | MUSIC FOR COUNCIL S - RURAL  | 1         | 1,586.68   |           |
| EFT44396       | 28/07/2022 | AUSTRALIAN TAXATION OFFICE - PAYG                                      | PAYG FOR PAY WEEK ENDING 19/07/2022  | 1         |            | 60,999.70 |
| INV PAYG 121   | 07/2022    | AUSTRALIAN TAXATION OFFICE - PAYG                                      | PAYG FOR PAY WEEK ENDING 19/07/2022  | 1         | 60,097.70  |           |
| INV PAYG 1     | 25/07/2022 | AUSTRALIAN TAXATION OFFICE - PAYG                                      | PAYG FOR PAY WEEK ENDING 19/07/2022 INTERIM (DAVID EMERY)                            | 1         | 902.00     |           |

Ordinary Council Meeting Agenda  
17 August 2022



Date: 01/08/2022  
Time: 9:17:37AM

Shire of Northam

USER: Louise Harris  
PAGE: 50 10

| Cheque /EFT No        | Date                               | Name  | Invoice Description   | Bank Code | INV Amount | Amount   |
|-----------------------|------------------------------------|---|---|-----------|------------|----------|
| EFT44397              | 28/07/2022                         | AVON SERVICE SPECIALISTS  | CHECK AND SERVICE VEHICLE - FORD RANGER N79 - 115,400KM   | 1         |            | 373.45   |
| INV 23597             | 11/07/2022                         | AVON SERVICE SPECIALISTS  | CHECK AND SERVICE VEHICLE - FORD RANGER N79 - 115,400KM   | 1         | 373.45     |          |
| EFT44398              | 28/07/2022                         | AVON VALLEY ARTS SOCIETY (INC)  | ART WORKS SOLD FOR COMMISSION - VISITORS CENTRE   | 1         |            | 923.81   |
| INV 1028              | 19/07/2022                         | AVON VALLEY ARTS SOCIETY (INC)  | ART WORKS SOLD FOR COMMISSION - VISITORS CENTRE   | 1         | 923.81     |          |
| EFT44399              | 28/07/2022                         | AVON VALLEY TOYOTA  | PN2018 - N10938 - VIN - MR0CB3DB005660578 - PLEASE CONDUCT THE 20,000KM SERVICE   | 1         |            | 394.89   |
| INV JC1400623/06/2022 | AVON VALLEY TOYOTA                 | PN2018 - N10938 - VIN - MR0CB3DB005660578 - PLEASE CONDUCT THE 20,000KM SERVICE   | 1   | 394.89    |            |          |
| EFT44400              | 28/07/2022                         | BEAZLEY FENCING - DE JEZERSKI T/AS  | TO SUPPLY AND INSTALL 48M OF CHAIN MESH FENCING AT 1800MM HIGH TO ENCLOSE LEAN-TO AND YARD, INCLUDING SINGLE ACCESS GATE AT 1200MM WIDE AND DOUBLE GATES AT 3.5M WIDE. CHAIN MESH PLAIN KNUCKLE/BARB MESH (SPIKE TOP MESH), GALVANIZED POSTS, CAPS, FITTINGS AND HORIZONTAL STAYS FOR THE GATES. CUSTOM GATES WITH KNUCKLE/BARB MESH, BLACK PVC COATED MESH AND WIRE ON FENCE AND GATES WITH GALVANIZED POSTS AND FITTINGS. AS PER QUOTE 00000087 | 1         |            | 8,360.00 |
| INV 000000922/07/2022 | BEAZLEY FENCING - DE JEZERSKI T/AS | TO SUPPLY AND INSTALL 48M OF CHAIN MESH FENCING AT 1800MM HIGH TO ENCLOSE LEAN-TO AND YARD, INCLUDING SINGLE ACCESS GATE AT 1200MM WIDE AND DOUBLE GATES AT 3.5M WIDE. CHAIN MESH PLAIN KNUCKLE/BARB MESH (SPIKE TOP MESH), GALVANIZED POSTS, CAPS, FITTINGS AND HORIZONTAL STAYS FOR THE GATES. CUSTOM GATES WITH KNUCKLE/BARB MESH, BLACK PVC COATED MESH AND WIRE ON FENCE AND GATES WITH GALVANIZED POSTS AND FITTINGS. AS PER QUOTE 00000087 | 1   | 8,360.00  |            |          |
| EFT44401              | 28/07/2022                         | BOYLE INDUSTRIES PTY LTD  | STOCK PURCHASES MUN   | 1         |            | 350.29   |
| INV 333784            | 14/07/2022                         | BOYLE INDUSTRIES PTY LTD  | STOCK PURCHASES MUN   | 1         | 350.29     |          |

Date: 01/08/2022  
Time: 9:17:37AM

Shire of Northam

USER: Louise Harris  
PAGE: 51 13

| Cheque /EFT No        | Date       | Name                              | Invoice Description                                  | Bank Code | INV Amount | Amount   |
|-----------------------|------------|-----------------------------------|--|-----------|------------|----------|
| EFT44402              | 28/07/2022 | BUNNINGS BUILDING SUPPLIES P/L    | PLANT-LAVENDER 175MM WINTER LACE                     | 1         |            | 727.96   |
|                       |            |                                   | PLANT-LAVENDER 140MM WINTER LACE                     |           |            |          |
| INV 2182/9918/07/2022 |            | BUNNINGS BUILDING SUPPLIES P/L    | 5 X BOLLARDS AND 30M ORANGE FLAG ROPING              | 1         | 115.00     |          |
| INV 2182/9918/07/2022 |            | BUNNINGS BUILDING SUPPLIES P/L    | 5 x BOLLARDS   | 1         | 113.58     |          |
| INV 2182/0019/07/2022 |            | BUNNINGS BUILDING SUPPLIES P/L    | 30M X ORANGE ROPE FLAGGING                           |           |            |          |
| INV 2182/0019/07/2022 |            | BUNNINGS BUILDING SUPPLIES P/L    | 4MM ADAPTORS FOR RETIC                               | 1         | 22.45      |          |
| INV 2182/0019/07/2022 |            | BUNNINGS BUILDING SUPPLIES P/L    | FLUG KINETIC 50MM BASIN BATH BRASS 403104 CHAIN      | 1         | 19.12      |          |
| INV 2182/0019/07/2022 |            | BUNNINGS BUILDING SUPPLIES P/L    | TWIST ZENITH 1.6MMX2.5M MATTE BLACK JTL1630          |           |            |          |
| INV 2182/0019/07/2022 |            | BUNNINGS BUILDING SUPPLIES P/L    | ADMIN BUILDING. SUPPLY 3 X TOILET SEATS.             | 1         | 126.60     |          |
| INV 2182/0020/07/2022 |            | BUNNINGS BUILDING SUPPLIES P/L    | DISC CUTTING MAKITA 115X1X22.23 INOX CUT 12PK x 2    | 1         | 28.32      |          |
| INV 2182/0020/07/2022 |            | BUNNINGS BUILDING SUPPLIES P/L    | PLANT-LAVENDER 175MM WINTER LACE                     | 1         | 302.89     |          |
|                       |            |                                   | PLANT-LAVENDER 140MM WINTER LACE                     |           |            |          |
| EFT44403              | 28/07/2022 | CENTRAL MOBILE MECHANICAL REPAIRS | FLOAT HIRE   | 1         |            | 1,419.00 |
| INV 000040819/07/2022 |            | CENTRAL MOBILE MECHANICAL REPAIRS | FLOAT HIRE   | 1         | 1,419.00   |          |
| EFT44404              | 28/07/2022 | CHARLES SERVICE COMPANY           | CLEANING OF SHIRE OF NORTHAM FACILITIES C.2021-04    | 1         |            | 7,294.74 |
|                       |            |                                   | - 20/6/2022 - 17/7/2022                              |           |            |          |
| INV 000348820/04/2022 |            | CHARLES SERVICE COMPANY           | C.202021-04- VO1 - WEEKLY CLEANING FOR WUNDOWIE      | 1         | 1,736.35   |          |
|                       |            |                                   | OVAL TOILETS 7X A WEEK AS PER QUOTE - 21/3/2022 -    |           |            |          |
|                       |            |                                   | 17/4/2022  |           |            |          |
| INV 000349722/05/2022 |            | CHARLES SERVICE COMPANY           | C.202021-04- VO1 - WEEKLY CLEANING FOR WUNDOWIE      | 1         | 1,916.75   |          |
|                       |            |                                   | OVAL TOILETS 7X A WEEK AS PER QUOTE - 18/04/2022 -   |           |            |          |
|                       |            |                                   | 22/05/2022   |           |            |          |
| INV 000350520/06/2022 |            | CHARLES SERVICE COMPANY           | C.202021-04- VO1 - WEEKLY CLEANING FOR WUNDOWIE      | 1         | 1,533.40   |          |
|                       |            |                                   | OVAL TOILETS 7X A WEEK AS PER QUOTE - 23 MAY 2022    |           |            |          |
|                       |            |                                   | - 19 JUNE 2022                                       |           |            |          |
| INV 000351130/06/2022 |            | CHARLES SERVICE COMPANY           | CREDIT DUPLICATE INVOICE 00034555 / CREDIT           | 1         | -6,516.95  |          |
|                       |            |                                   | OVERCHARGE ON INVOICE 00034597 / 00034679 / 00034794 |           |            |          |
| INV 000351520/07/2022 |            | CHARLES SERVICE COMPANY           | CLEANING OF SHIRE OF NORTHAM FACILITIES C.2021-04    | 1         | 8,625.19   |          |
|                       |            |                                   | - 20/6/2022 - 17/7/2022                              |           |            |          |
| EFT44405              | 28/07/2022 | CLARK EQUIPMENT                   | FN0916 - CROWD BUCKET RAM - PART NUMBER 7117174      | 1         |            | 2,192.91 |
|                       |            |                                   | CYLINDER AS QUOTED                                   |           |            |          |
| INV 082454130/05/2022 |            | CLARK EQUIPMENT                   | FN0916 - CROWD BUCKET RAM - PART NUMBER 7117174      | 1         | 2,192.91   |          |
|                       |            |                                   | CYLINDER AS QUOTED                                   |           |            |          |

Date: 01/08/2022  
Time: 9:17:37AM

Shire of Northam

USER: Louise Harris  
PAGE: 52 10

| Cheque /EFT No | Date       | Name                           | Invoice Description  | Bank Code | INV Amount | Amount    |
|----------------|------------|--------------------------------|--|-----------|------------|-----------|
| EFT44406       | 28/07/2022 | CLOUD COLLECTIONS PTY LTD      | REFUND OF PAYMENT MADE IN ERROR  | 1         |            | 350.00    |
| INV CY 210721  | 07/2022    | CLOUD COLLECTIONS PTY LTD      | REFUND OF PAYMENT MADE IN ERROR  | 1         | 350.00     |           |
| EFT44407       | 28/07/2022 | COMISKEY'S CONTRACTING PTY LTD | CONSTRUCITON OF NORTHAM WASTE TRANSFER FACILITY AS PER CONTRACT C.202021-26. - PROGRESS CLAIM 10 | 1         |            | 51,977.08 |
| INV 220702     | 08/07/2022 | COMISKEY'S CONTRACTING PTY LTD | CONSTRUCITON OF NORTHAM WASTE TRANSFER FACILITY AS PER CONTRACT C.202021-26. - PROGRESS CLAIM 10 | 1         | 51,977.08  |           |
| EFT44408       | 28/07/2022 | COUNTRY COMFORT STYLE NORTHAM  | ENTERPRISE OFFICE CHAIR BLACK & ARAGON MESH BACK CHAIR WITH ARMS BLACK                           | 1         |            | 948.00    |
| INV 17646      | 21/07/2022 | COUNTRY COMFORT STYLE NORTHAM  | ENTERPRISE OFFICE CHAIR BLACK & ARAGON MESH BACK CHAIR WITH ARMS BLACK                           | 1         | 948.00     |           |
| EFT44409       | 28/07/2022 | COUNTRYWIDE GROUP              | CATCHER FOR HONDA MOWER  | 1         |            | 599.56    |
| INV ACC00120   | 07/2022    | COUNTRYWIDE GROUP              | SPRING FOR PN1903  | 1         | 9.52       |           |
| INV ACC00120   | 07/2022    | COUNTRYWIDE GROUP              | CHAINS FOR POLESAW AND CHAINSAW  | 1         | 197.00     |           |
| INV ACC00122   | 07/2022    | COUNTRYWIDE GROUP              | CHAINSAW FULL SERVICE  | 1         | 183.04     |           |
| INV ACC00123   | 07/2022    | COUNTRYWIDE GROUP              | CATCHER FOR HONDA MOWER  | 1         | 210.00     |           |
| EFT44410       | 28/07/2022 | COUNTRYWIDE POOLS              | REFUND OF INFRASTRUCTURE BOND - NO DAMAGE  | 1         |            | 1,020.00  |
| INV T1638      | 28/07/2022 | COUNTRYWIDE POOLS              | REFUND OF INFRASTRUCTURE BOND - NO DAMAGE  | 1         | 1,020.00   |           |
| EFT44411       | 28/07/2022 | CTI SECURITY SERVICES PTY LTD  | SHIRE OF NORTHAM SITES - SECURITY ALARM MONITORING FROM 01/08/2022 - 31/08/2022                  | 1         |            | 798.07    |
| INV CINS31     | 19/07/2022 | CTI SECURITY SERVICES PTY LTD  | SHIRE OF NORTHAM SITES - SECURITY ALARM MONITORING FROM 01/08/2022 - 31/08/2022                  | 1         | 798.07     |           |
| EFT44412       | 28/07/2022 | DCM CARPENTRY & MAINTENANCE    | SUPPLY, INSTALL AND PAINTING OF 3 POLES WITH CONCRETE FOOTING AT THE VILLAGE GREEN               | 1         |            | 4,295.50  |
| INV 1421       | 29/06/2022 | DCM CARPENTRY & MAINTENANCE    | INSTALL TV INTO FRONT RECEPTION - ADDITONAL WALL MOPUNTING REQUIRED FOR SAFETY AND TO HOLD TV.   | 1         | 1,644.50   |           |

Ordinary Council Meeting Agenda  
17 August 2022

Date: 01/08/2022  
Time: 9:17:37AM

Shire of Northam

USER: Louise Harris  
PAGE: 53 13

| Cheque /EFT No        | Date       | Name  | Invoice Description   | Bank Code | INV Amount | Amount    |
|-----------------------|------------|---|---|-----------|------------|-----------|
| INV 1420              | 30/06/2022 | DCM CARPENTRY & MAINTENANCE                     | SUPPLY, INSTALL AND PAINTING OF 3 POLES WITH CONCRETE FOOTING AT THE VILLAGE GREEN    | 1         | 2,651.00   |           |
| EFT44413              | 28/07/2022 | DRACO AIR PTY LTD                               | BERT HAWKE PAVILION. REPAIR HEATING IN AIRCONDITIONERS.                               | 1         |            | 264.00    |
| INV 14737             | 19/07/2022 | DRACO AIR PTY LTD                               | BERT HAWKE PAVILION. REPAIR HEATING IN AIRCONDITIONERS.                               | 1         | 264.00     |           |
| EFT44414              | 28/07/2022 | EASTERN METROPOLITAN REGIONAL COUNCIL           | EMRC - AVON DESCENT FAMILY FUN DAYS 2022  | 1         |            | 5,500.00  |
| INV EMRC418/07/2022   | 28/07/2022 | EASTERN METROPOLITAN REGIONAL COUNCIL           | EMRC - AVON DESCENT FAMILY FUN DAYS 2022  | 1         | 5,500.00   |           |
| EFT44415              | 28/07/2022 | EQUIFAX AUSTRALASIA WORKFORCE SOLUTIONS PTY LTD | INDIVIDUAL REPORTS FOR NEW VOLUNTEER FIREFIGHTING MEMBERS - AUGUST 2021               | 1         |            | 41.69     |
| INV 149478631/08/2021 | 28/07/2022 | EQUIFAX AUSTRALASIA WORKFORCE SOLUTIONS PTY LTD | INDIVIDUAL REPORTS FOR NEW VOLUNTEER FIREFIGHTING MEMBERS - AUGUST 2021               | 1         | 41.69      |           |
| EFT44416              | 28/07/2022 | GOODYEAR & DUNLOP TYRES (AUST) PTY LTD          | FN1608 - MULTI ROLLER PUNCTURE REPAIR ON SITE WOOTTATING RD                           | 1         |            | 430.12    |
| INV 641267420/07/2022 | 28/07/2022 | GOODYEAR & DUNLOP TYRES (AUST) PTY LTD          | SUPPLY TUBE FOR MOWER   | 1         | 20.00      |           |
| INV 641267822/07/2022 | 28/07/2022 | GOODYEAR & DUNLOP TYRES (AUST) PTY LTD          | FN1608 - MULTI ROLLER PUNCTURE REPAIR ON SITE WOOTTATING RD                           | 1         | 376.65     |           |
| INV 641267925/07/2022 | 28/07/2022 | GOODYEAR & DUNLOP TYRES (AUST) PTY LTD          | FN1307 - REPAIR PUNCTURE  | 1         | 33.47      |           |
| EFT44417              | 28/07/2022 | GRAFTON ELECTRICS                               | MINSON AVE STREET LIGHTS. REPLACE BROKEN LIGHTS WITH LED AND GLOBES AS PER QUOTE 122. | 1         |            | 9,599.70  |
| INV 8822              | 19/07/2022 | GRAFTON ELECTRICS                               | OLD TOWN ADMIN. INVESTIGATE/REPAIR FRONT AUTOMATIC DOOR OPENING RANDOMLY.             | 1         | 209.00     |           |
| INV 8798              | 22/07/2022 | GRAFTON ELECTRICS                               | MINSON AVE STREET LIGHTS. REPLACE BROKEN LIGHTS WITH LED AND GLOBES AS PER QUOTE 122. | 1         | 8,444.70   |           |
| INV 8831              | 22/07/2022 | GRAFTON ELECTRICS                               | MINSON AVE STREET LIGHTS. REPAIR EXTRA LLIGHTS FROM INSPECTION.                       | 1         | 946.00     |           |
| EFT44418              | 28/07/2022 | ID CONSULTING PTY LTD                           | PROFILE.ID / ATLAS.ID / ECONOMY.ID - SUBSCRIPTION FEE 01/07/2022-30/06/2023           | 1         |            | 19,965.00 |
| INV 000143207/07/2022 | 28/07/2022 | ID CONSULTING PTY LTD                           | PROFILE.ID / ATLAS.ID / ECONOMY.ID - SUBSCRIPTION FEE 01/07/2022-30/06/2023           | 1         | 19,965.00  |           |

Ordinary Council Meeting Agenda  
17 August 2022



Date: 01/08/2022  
Time: 9:17:37AM

Shire of Northam

USER: Louise Harris  
PAGE: 54 10

| Cheque /EFT No        | Date       | Name   | Invoice Description   | Bank Code | INV Amount | Amount   |
|-----------------------|------------|--|---|-----------|------------|----------|
| EFT44419              | 28/07/2022 | INTERFIRE AGENCIES PTY LTD T/A LOVETT FAMILY TRUST | PACIFIC EASION SLIDE TORCH HOLDER B2066146 NIGHTSTICK X-SERIES SAFETY RATED LED TORCH | 1         |            | 1,522.95 |
| INV 10925             | 21/07/2022 | INTERFIRE AGENCIES PTY LTD T/A LOVETT FAMILY TRUST | PACIFIC EASION SLIDE TORCH HOLDER B2066146 NIGHTSTICK X-SERIES SAFETY RATED LED TORCH | 1         | 1,522.95   |          |
| EFT44420              | 28/07/2022 | JEF SALES & SERVICE                                | HEDGE TRIMMER SERVICE STIHL HS82T   | 1         |            | 84.42    |
| INV 41                | 21/07/2022 | JEF SALES & SERVICE                                | HEDGE TRIMMER SERVICE STIHL HS82T   | 1         | 84.42      |          |
| EFT44421              | 28/07/2022 | KAREN ANNBLURTON                                   | CATERING KANGEROO STEW AND DAMPER-NAIDOC EVENT 2022- INGREDIENTS AND LABOUR           | 1         |            | 500.00   |
| INV 15                | 07/07/2022 | KAREN ANNBLURTON                                   | CATERING KANGEROO STEW AND DAMPER-NAIDOC EVENT 2022- INGREDIENTS AND LABOUR           | 1         | 500.00     |          |
| EFT44422              | 28/07/2022 | KATHY DAVIS  | PAYMENT FOR COLLECTION OF STORY - BKB STAGE 2   | 1         |            | 300.00   |
| INV 16                | 12/07/2022 | KATHY DAVIS  | PAYMENT FOR COLLECTION OF STORY - BKB STAGE 2   | 1         | 300.00     |          |
| EFT44423              | 28/07/2022 | KLEENHEAT GAS                                      | GAS FOR NORTHAM SWIMMING POOL - JULY 2022   | 1         |            | 214.20   |
| INV 219693714/07/2022 |            | KLEENHEAT GAS                                      | GAS FOR NORTHAM SWIMMING POOL - JULY 2022   | 1         | 214.20     |          |
| EFT44424              | 28/07/2022 | LFA FIRST RESPONSE                                 | VENTOLIN INHALER 200 METERED DOSES  | 1         |            | 203.01   |
| INV IN2514612/07/2022 |            | LFA FIRST RESPONSE                                 | VENTOLIN INHALER 200 METERED DOSES  | 1         | 203.01     |          |
| EFT44425              | 28/07/2022 | LIGHT APPLICATION PTY LTD                          | SUSPENSION BRIDGE LIGHTING. 5 YEAR RENEWAL FOR PHAROS CLOUD AND 4G CONNECTION.        | 1         |            | 3,573.63 |
| INV 85464             | 20/07/2022 | LIGHT APPLICATION PTY LTD                          | SUSPENSION BRIDGE LIGHTING. 5 YEAR RENEWAL FOR PHAROS CLOUD AND 4G CONNECTION.        | 1         | 3,573.63   |          |
| EFT44426              | 28/07/2022 | LOCAL GOVERNMENT PROFESSIONALS AUSTRALIA WA        | LOCAL GOVERNMENT PROFESSIONALS MEMBERSHIP RENEWAL FOR COLIN YOUNG                     | 1         |            | 531.00   |
| INV 27083             | 01/07/2022 | LOCAL GOVERNMENT PROFESSIONALS AUSTRALIA WA        | LOCAL GOVERNMENT PROFESSIONALS MEMBERSHIP RENEWAL FOR COLIN YOUNG                     | 1         | 531.00     |          |
| EFT44427              | 28/07/2022 | LUME BRASSERIE - MADEELA PL T/AS                   | CATERING - ORDINARY COUNCIL MEETING 20 JULY 2022                                      | 1         |            | 520.00   |
| INV SHIRE 220/07/2022 |            | LUME BRASSERIE - MADEELA PL T/AS                   | CATERING - ORDINARY COUNCIL MEETING 20 JULY 2022                                      | 1         | 520.00     |          |
| EFT44428              | 28/07/2022 | MALINOWSKI HOLDINGS PTY LTD                        | RENT FOR 174 FITZGERAL ST (AVON MALL) 01/07/2022-31/07/2022                           | 1         |            | 1,145.84 |



Ordinary Council Meeting Agenda  
17 August 2022



Date: 01/08/2022  
Time: 9:17:37AM

Shire of Northam

USER: Louise Harris  
PAGE: 55 13

| Cheque /EFT No         | Date       | Name  | Invoice Description   | Bank Code | INV Amount | Amount   |
|------------------------|------------|---|---|-----------|------------|----------|
| INV 000005727/06/2022  |            | MALINOWSKI HOLDINGS PTY LTD                               | RENT FOR 174 FITZGERAL ST (AVON MALL)<br>01/07/2022-31/07/2022  | 1         | 1,145.84   |          |
| EFT44429               | 28/07/2022 | MAYBERRY HAMMOND & CO                                     | LEASE FOR PISTOL CLUB   | 1         |            | 1,302.60 |
| INV 44370              | 16/06/2022 | MAYBERRY HAMMOND & CO                                     | TRANSFER OF LEASE HANGAR 12 TO DAMIAN ODRISCOLL   | 1         | 572.00     |          |
| INV 44420              | 13/07/2022 | MAYBERRY HAMMOND & CO                                     | LEASE FOR PISTOL CLUB   | 1         | 730.60     |          |
| EFT44430               | 28/07/2022 | MAYDAY EARTHMOVING / RENTAL - CHIVAS ENTERPRISES T-AS     | 1 DAY DOZER DRY HIRE / DEMOB  | 1         |            | 2,398.00 |
| INV 82405              | 01/07/2022 | MAYDAY EARTHMOVING / RENTAL - CHIVAS ENTERPRISES T-AS     | 1 DAY DOZER DRY HIRE / DEMOB  | 1         | 2,398.00   |          |
| EFT44431               | 28/07/2022 | MINT CIVIL PTY LTD T/AS IMMACU SWEEP                      | C.201819-12 STREET SWEEPING & GULLY EDUCATION SERVICES (CLEANING TOWN ROADS) / FOOTPATH & VERGE SWEEPING OF CBD FROM 27/6/2022 - 3/7/2022 | 1         |            | 7,801.20 |
| INV N3029              | 11/07/2022 | MINT CIVIL PTY LTD T/AS IMMACU SWEEP                      | C.201819-12 STREET SWEEPING & GULLY EDUCATION SERVICES (CLEANING TOWN ROADS) / FOOTPATH & VERGE SWEEPING OF CBD FROM 27/6/2022 - 3/7/2022 | 1         | 3,900.60   |          |
| INV N3030              | 11/07/2022 | MINT CIVIL PTY LTD T/AS IMMACU SWEEP                      | C.201819-12 STREET SWEEPING & GULLY EDUCATION SERVICES (CLEANING TOWN ROADS) / FOOTPATH & VERGE SWEEPING OF CBD FROM 4/7/2022 - 10/7/2022 | 1         | 3,900.60   |          |
| EFT44432               | 28/07/2022 | NORTHAM AUTOS PTY LTD T/AS NORTHAM MAZDA & NORTHAM HOLDEN | PN2019 - N9467 - VIN - TSMLYD21S00907326 - PLEASE CONDUCT 20,000KM SERVICE  | 1         |            | 329.00   |
| INV 137842             | 23/06/2022 | NORTHAM AUTOS PTY LTD T/AS NORTHAM MAZDA & NORTHAM HOLDEN | PN2019 - N9467 - VIN - TSMLYD21S00907326 - PLEASE CONDUCT 20,000KM SERVICE  | 1         | 329.00     |          |
| EFT44433               | 28/07/2022 | NORTHAM DISTRICTS GLASS PTY LTD                           | PN1305 - 1GZQ718 - ISUZU 2014 TRUCK REQUIRES DRIVERS SIDE WINDOW REPLACEMENT  | 1         |            | 550.00   |
| INV INV-26328/06/2022  |            | NORTHAM DISTRICTS GLASS PTY LTD                           | PN1305 - 1GZQ718 - ISUZU 2014 TRUCK REQUIRES DRIVERS SIDE WINDOW REPLACEMENT  | 1         | 550.00     |          |
| EFT44434               | 28/07/2022 | NORTHAM LIQUOR BARONS                                     | STOCK FOR COUNCIL CHAMBERS  | 1         |            | 351.93   |
| INV 385944             | 20/07/2022 | NORTHAM LIQUOR BARONS                                     | STOCK FOR COUNCIL CHAMBERS  | 1         | 351.93     |          |
| EFT44435               | 28/07/2022 | NORTHAM MOTORS PTY LTD                                    | PN1915 - N11206 - 60,000KM SERVICE  | 1         |            | 610.01   |
| INV 14234661/10/7/2022 |            | NORTHAM MOTORS PTY LTD                                    | PN1915 - N11206 - 60,000KM SERVICE  | 1         | 610.01     |          |

Ordinary Council Meeting Agenda  
17 August 2022



Date: 01/08/2022  
Time: 9:17:37AM

Shire of Northam

USER: Louise Harris  
PAGE: 56 10

| Cheque /EFT No        | Date       | Name  | Invoice Description   | Bank Code | INV Amount | Amount   |
|-----------------------|------------|---|---|-----------|------------|----------|
| EFT44436              | 28/07/2022 | NORTHAM TOWING SERVICE  | PN2013 - N.4098 - TOYOTA RAV4 PICKUP FROM 86 CHIDLLOW ST NORTHAM, DROP OFF AT AVON VALLEY TOYOTA 32 FITZGERALD ST NORTHAM.  | 1         |            | 80.00    |
| INV 211577            | 12/07/2022 | NORTHAM TOWING SERVICE  | PN2013 - N.4098 - TOYOTA RAV4 PICKUP FROM 86 CHIDLLOW ST NORTHAM, DROP OFF AT AVON VALLEY TOYOTA 32 FITZGERALD ST NORTHAM.  | 1         | 80.00      |          |
| EFT44437              | 28/07/2022 | OFFICEWORKS SUPERSTORES PTY LTD   | 2 X ACER 15.6" ASPIRE 3 NOTEBOOK CORE I5 8/256GB WIN11 / 2 X JBURROWS 15.6" LAPTOP BAG WITH EXTERNAL ZIP POCKET BLACK / 2 X KEJI 2.4G WIRELESS KEYBOARD AND MOUSE COMBO | 1         |            | 1,536.95 |
| INV 601305015/06/2022 | 06/2022    | OFFICEWORKS SUPERSTORES PTY LTD   | 2 X ACER 15.6" ASPIRE 3 NOTEBOOK CORE I5 8/256GB WIN11 / 2 X JBURROWS 15.6" LAPTOP BAG WITH EXTERNAL ZIP POCKET BLACK / 2 X KEJI 2.4G WIRELESS KEYBOARD AND MOUSE COMBO | 1         | 1,536.95   |          |
| EFT44438              | 28/07/2022 | PRESTIGE ALARMS   | ADMIN BUILDING. SUPPLY AND POST TO SITE 10 X SECURITY FOBS TO REPLACE BROKEN AND LOST UNITS.  | 1         |            | 189.53   |
| INV 519510            | 20/07/2022 | PRESTIGE ALARMS   | ADMIN BUILDING. SUPPLY AND POST TO SITE 10 X SECURITY FOBS TO REPLACE BROKEN AND LOST UNITS.  | 1         | 189.53     |          |
| EFT44439              | 28/07/2022 | PROMOPAL PTY LTD  | UMBRELLA CANOPY VILLAGE GREEN BILYA FESTIVAL 2022-MELBOURNE UMBRELLAS-MIX OF COLOURS-DELIVERY BY AUGUST   | 1         |            | 6,377.80 |
| INV INV-14714/06/2022 | 06/2022    | PROMOPAL PTY LTD  | UMBRELLA CANOPY VILLAGE GREEN BILYA FESTIVAL 2022-MELBOURNE UMBRELLAS-MIX OF COLOURS-DELIVERY BY AUGUST   | 1         | 6,377.80   |          |
| EFT44440              | 28/07/2022 | PUBLIC TRANSPORT AUTHORITY  | TRAIN TICKET SALES FOR JUNE 2022  | 1         |            | 41.75    |
| INV 399930            | 30/06/2022 | PUBLIC TRANSPORT AUTHORITY  | TRAIN TICKET SALES FOR JUNE 2022  | 1         | 41.75      |          |
| EFT44441              | 28/07/2022 | RONLIEEH PTY LTD T/AS ALL PARTS WA  | PN1518 - BELTS FOR FLAIL MOWER  | 1         |            | 141.90   |
| INV SI-0000           | 20/07/2022 | RONLIEEH PTY LTD T/AS ALL PARTS WA  | PN1518 - BELTS FOR FLAIL MOWER  | 1         | 141.90     |          |
| EFT44442              | 28/07/2022 | S&K SPADACCINI FAMILY HOME BUILDERS PL T/AS SIMON SPADACCINI CONSTRUCTION | REFUND OF INFRASTRUCTURE BOND - NO DAMAGE   | 1         |            | 1,020.00 |

Ordinary Council Meeting Agenda  
17 August 2022



Date: 01/08/2022  
Time: 9:17:37AM

Shire of Northam

USER: Louise Harris  
PAGE: 57/13

| Cheque /EFT No        | Date       | Name  | Invoice Description   | Bank Code | INV Amount | Amount    |
|-----------------------|------------|---|---|-----------|------------|-----------|
| INV T1601             | 28/07/2022 | S&K SPADACCINI FAMILY HOME BUILDERS PL T/AS SIMON SPADACCINI CONSTRUCTION | REFUND OF INFRASTRUCTURE BOND - NO DAMAGE   | 1         | 1,020.00   |           |
| EFT44443              | 28/07/2022 | SHANE ASHMAN  | RATES REFUND FOR ASSESSMENT A15588  | 1         |            | 649.69    |
| INV A15588            | 20/07/2022 | SHANE ASHMAN  | RATES REFUND FOR ASSESSMENT A15588  |           | 376.59     |           |
| INV CY 280728/07/2022 | 28/07/2022 | SHANE ASHMAN  | REFUND OF LEASE PAYMENT FOR HANGAR 12 - SOLD ON 8/2/2022                            | 1         | 273.10     |           |
| EFT44444              | 28/07/2022 | SHRED-X PTY LTD   | DESTRUCTION OF ARCHIVED BOXES   | 1         |            | 314.52    |
| INV 018372030/06/2022 | 28/07/2022 | SHRED-X PTY LTD   | DESTRUCTION OF ARCHIVED BOXES   | 1         | 314.52     |           |
| EFT44445              | 28/07/2022 | SILVER WINGS SENIOR'S CLUB INC.   | REFUND SILVER WINGS GROUP FOR THE PURCHASE OF FUEL - WUNDOWIE COMMUNITY BUS         | 1         |            | 40.08     |
| INV 003910118/07/2022 | 28/07/2022 | SILVER WINGS SENIOR'S CLUB INC.   | REFUND SILVER WINGS GROUP FOR THE PURCHASE OF FUEL - WUNDOWIE COMMUNITY BUS         | 1         | 40.08      |           |
| EFT44446              | 28/07/2022 | SONTEC INTEGRATED SYSTEMS   | EMERGENCY REPAIR TO SECURITY DOOR TIMING  | 1         |            | 1,035.21  |
| INV 18896             | 12/07/2022 | SONTEC INTEGRATED SYSTEMS   | EMERGENCY REPAIR TO SECURITY DOOR TIMING  | 1         | 1,035.21   |           |
| EFT44447              | 28/07/2022 | SPORTSPOWER NORTHAM H & H JOUBERT   | WHISTLES FOR STAFF TO UMPIRE SOCIAL SPORTS  | 1         |            | 100.00    |
| INV 22-000021/07/2022 | 28/07/2022 | SPORTSPOWER NORTHAM H & H JOUBERT   | WHISTLES FOR STAFF TO UMPIRE SOCIAL SPORTS  | 1         | 10.00      |           |
| INV 22-000021/07/2022 | 28/07/2022 | SPORTSPOWER NORTHAM H & H JOUBERT   | WHISTLES FOR STAFF TO UMPIRE SOCIAL SPORTS  | 1         | 90.00      |           |
| EFT44448              | 28/07/2022 | SYNERGY   | 168614990 STREETLIGHTING - 25/05/2022 to 24/06/2022                                 | 1         |            | 42,657.36 |
| INV 915241604/07/2022 | 28/07/2022 | SYNERGY   | 915241640 AUXILLARY LIGHTING - 28/05/2022 to 27/07/2022                             | 1         | 144.24     |           |
| INV 168614904/07/2022 | 28/07/2022 | SYNERGY   | 168614990 STREETLIGHTING - 25/05/2022 to 24/06/2022                                 | 1         | 25,395.98  |           |
| INV 293110713/07/2022 | 28/07/2022 | SYNERGY   | 293110730 BILYA KOORT BOODJA - 08/06/2022 to 12/07/2022                             |           | 1,575.67   |           |
| INV 361669313/07/2022 | 28/07/2022 | SYNERGY   | 361669310 RECREATION PRECINCT - NORTHAM AQUATIC FACILITY - 08/06/2022 to 12/07/2022 |           | 10,051.24  |           |
| INV 357547718/07/2022 | 28/07/2022 | SYNERGY   | 357547710 MOUNT OMMANNEY - CCTV - 17/05/2022 to 13/07/2022                          |           | 132.69     |           |
| INV 941453220/07/2022 | 28/07/2022 | SYNERGY   | 941453230 GRASS VALLEY BFB FIRE SHED - 20/05/2022 to 18/07/2022                     |           | 301.22     |           |

Date: 01/08/2022  
Time: 9:17:37AM

Shire of Northam

USER: Louise Harris  
PAGE: 58 10

| Cheque /EFT No        | Date       | Name                   | Invoice Description  | Bank Code | INV Amount | Amount   |
|-----------------------|------------|------------------------|--|-----------|------------|----------|
| INV 357547321/07/2022 |            | SYNERGY                | 357547330 APEX PARK TOILETS - 25/05/2022 to 19/07/2022   |           | 182.88     |          |
| INV 136537721/07/2022 |            | SYNERGY                | 136537740 AIRPORT - 16/06/2022 to 20/07/2022   |           | 1,515.67   |          |
| INV 811029421/07/2022 |            | SYNERGY                | 811029470 WUNDOWIE SWIMMING POOL - 29/06/2022 to 20/07/2022  |           | 611.57     |          |
| INV 361670221/07/2022 |            | SYNERGY                | 361670250 NORTHAM LIBRARY - 16/06/2022 to 20/07/2022   |           | 521.00     |          |
| INV 361333121/07/2022 |            | SYNERGY                | 361333180 SUSPENSION BRIDGE LIGHTING - 25/05/2022 to 19/07/2022                                    |           | 358.44     |          |
| INV 357549621/07/2022 |            | SYNERGY                | 357549690 KILLARA DAYCARE CENTRE - COTTAGE - 16/06/2022 to 20/07/2022                              |           | 1,587.75   |          |
| INV 357547421/07/2022 |            | SYNERGY                | 357547470 MORBY COTTAGE - 28/06/2022 to 18/07/2022   |           | 113.11     |          |
| INV 157822522/07/2022 |            | SYNERGY                | 157822560 IRISHTOWN BFB - 24/05/2022 to 21/07/2022   |           | 165.90     |          |
| EFT44449              | 28/07/2022 | THE BOOK SHED          | PAINT LETTERING ON TO CONCRETE AT BERNARD PARK   | 1         |            | 1,309.00 |
| INV INV-22130/06/2022 |            | THE BOOK SHED          | PAINT LETTERING ON TO CONCRETE AT BERNARD PARK   | 1         | 1,309.00   |          |
| EFT44450              | 28/07/2022 | THE PRINT SHOP BUNBURY | NO UNAUTHORISED PARKING, PRESS GREEN BUTTON X 2  | 1         |            | 299.20   |
| INV 151447830/06/2022 |            | THE PRINT SHOP BUNBURY | SIGNAGE FOR NORTHAM POOL<br>NO UNAUTHORISED PARKING, PRESS GREEN BUTTON X 2                        | 1         | 299.20     |          |
| EFT44451              | 28/07/2022 | THE WORKWEAR GROUP     | UNIFORMS - LOUISE HARRIS   | 1         |            | 1,029.55 |
| INV 137334514/01/2022 |            | THE WORKWEAR GROUP     | UNIFORM ITEMS FOR WASTE MANAGEMENT OFFICER ANNEMAREE JENSEN - 1 X SKU CAT3CA SIZE 14 AND IN BLACK. | 1         | 121.00     |          |
| INV 140657910/06/2022 |            | THE WORKWEAR GROUP     | UNIFORMS - BOBBI JO  | 1         | 247.59     |          |
| INV 140938321/06/2022 |            | THE WORKWEAR GROUP     | UNIFORMS - LEE MCLELLAN  | 1         | 132.86     |          |
| INV 141641708/07/2022 |            | THE WORKWEAR GROUP     | UNIFORMS - ALISON QUIN   | 1         | 183.49     |          |
| INV 141771715/07/2022 |            | THE WORKWEAR GROUP     | UNIFORMS - LOUISE HARRIS   | 1         | 344.61     |          |

Date: 01/08/2022  
Time: 9:17:37AM

Shire of Northam

USER: Louise Harris  
PAGE: 59 13

| Cheque /EFT No        | Date       | Name   | Invoice Description   | Bank Code | INV Amount | Amount   |
|-----------------------|------------|--|---|-----------|------------|----------|
| EFT44452              | 28/07/2022 | THYLACTINE DESIGN & PROJECT MANAGEMENT         | COLLECTION OF STORIES   | 1         |            | 4,400.00 |
| INV 201035030/06/2022 |            | THYLACTINE DESIGN & PROJECT MANAGEMENT         | COLLECTION OF STORIES   | 1         | 4,400.00   |          |
| EFT44453              | 28/07/2022 | TOLL - IPEC PTY LTD T/AS                       | TOLL FREIGHT - POOL / CESM / HEALTH - JUNE 2022   | 1         |            | 56.54    |
| INV 0550-S326/06/2022 |            | TOLL - IPEC PTY LTD T/AS                       | TOLL FREIGHT - POOL / CESM / HEALTH - JUNE 2022   | 1         | 56.54      |          |
| EFT44454              | 28/07/2022 | WA FARM SHOP - TAA GROUP HOLDINGS PTY LTD T/AS | BAILEYS VITA FLANT 200 LITRES   | 1         |            | 2,346.74 |
| INV 100000022/07/2022 |            | WA FARM SHOP - TAA GROUP HOLDINGS PTY LTD T/AS | BAILEYS VITA FLANT 200 LITRES   | 1         | 2,346.74   |          |
| EFT44455              | 28/07/2022 | WAY SIGNS                                      | WHITE REFLECTIVE 75MM NUMBERS FOR RURAL SIGNAGE - 4, 5 & 8  | 1         |            | 264.00   |
| INV INV-28927/03/2022 |            | WAY SIGNS                                      | WHITE REFLECTIVE 75MM NUMBERS FOR RURAL SIGNAGE - 4, 5 & 8  | 1         | 264.00     |          |
| EFT44456              | 28/07/2022 | WEST OZ WILDLIFE                               | WILDLIFE EXHIBIT/STALL BILYA FETSIVAL 12TH AUGUST 2022- 3HRS - 5PM TILL 8PM<br>2 KEEPERS PYTHONS, BOB TAILED LIZARDS, BLUE TONGUES, FRILLED NECKED LIZARDS, KOALA. SUPPLY OUR BRANDED 6 X 3 MARQUEE, WITH ACTIVITY TABLES AND TOUCH AND FEEL TRAYS. | 1         |            | 1,127.50 |
| INV 3097              | 19/07/2022 | WEST OZ WILDLIFE                               | WILDLIFE EXHIBIT/STALL BILYA FETSIVAL 12TH AUGUST 2022- 3HRS - 5PM TILL 8PM<br>2 KEEPERS PYTHONS, BOB TAILED LIZARDS, BLUE TONGUES, FRILLED NECKED LIZARDS, KOALA. SUPPLY OUR BRANDED 6 X 3 MARQUEE, WITH ACTIVITY TABLES AND TOUCH AND FEEL TRAYS. | 1         | 1,127.50   |          |
| EFT44457              | 28/07/2022 | WESTWIDE AUTO ELECTRICS AND AIR CONDITIONING   | GRASS VALLEY 4.4 - REPLACE BATTERIES WITH AGM BATTERIES TEST ELECTRICAL AND CHARGING SYSTEM FOR COMPLIANCE  | 1         |            | 2,100.00 |
| INV INV136 17/06/2022 |            | WESTWIDE AUTO ELECTRICS AND AIR CONDITIONING   | GRASS VALLEY 4.4 - REPLACE BATTERIES WITH AGM BATTERIES TEST ELECTRICAL AND CHARGING SYSTEM FOR COMPLIANCE  | 1         | 1,250.00   |          |

Ordinary Council Meeting Agenda  
17 August 2022



Date: 01/08/2022  
Time: 9:17:37AM

Shire of Northam

USER: Louise Harris  
PAGE: 60/10

| Cheque /EFT No        | Date       | Name   | Invoice Description  | Bank Code | INV Amount | Amount    |
|-----------------------|------------|--|--|-----------|------------|-----------|
| INV INV-13617/06/2022 |            | WESTWIDE AUTO ELECTRICS AND AIR CONDITIONING | GRASS VALLEY 4.4 - REPLACE BATTERIES WITH AGM BATTERIES TEST ELECTRICAL AND CHARGING SYSTEM FOR COMPLIANCE | 1         | 87.50      |           |
| INV INV-13730/06/2022 |            | WESTWIDE AUTO ELECTRICS AND AIR CONDITIONING | DIAGNOSE AND REPAIR/REPLACE BATTERIES ON 3.4U  | 1         | 762.50     |           |
| EFT44458              | 28/07/2022 | WHEATBELT OFFICE & BUSINESS MACHINES (WOBM)  | 1 X MICROSOFT WIRELESS KEYBOARD + MOUSE COMBO  | 1         |            | 87.00     |
| INV 29106             | 05/07/2022 | WHEATBELT OFFICE & BUSINESS MACHINES (WOBM)  | 1 X MICROSOFT WIRELESS KEYBOARD + MOUSE COMBO  | 1         | 43.50      |           |
| INV 29114             | 05/07/2022 | WHEATBELT OFFICE & BUSINESS MACHINES (WOBM)  | 1 X MICROSOFT WIRELESS KEYBOARD + MOUSE COMBO  | 1         | 43.50      |           |
| EFT44459              | 28/07/2022 | WHEATBELT SERVICES PTY LTD                   | SIGNAGE - MULUCKINE RD / OLIVER RD / KEEP LEFT / DO NOT FEED BIRDS / BLACK SPOT                            | 1         |            | 785.40    |
| INV 000003318/07/2022 |            | WHEATBELT SERVICES PTY LTD                   | SIGNAGE - MULUCKINE RD / OLIVER RD / KEEP LEFT / DO NOT FEED BIRDS / BLACK SPOT                            | 1         | 785.40     |           |
| EFT44460              | 28/07/2022 | WINPRO ELECTRICAL                            | SUPPLY/INSTALL CCTV AT NORTHAM ANIMAL POUND  | 1         |            | 2,189.00  |
| INV INV-19327/06/2022 |            | WINPRO ELECTRICAL                            | SUPPLY/INSTALL CCTV AT NORTHAM ANIMAL POUND  | 1         | 2,189.00   |           |
| DD17966.1             | 13/07/2022 | BANKWEST                                     | BRENDAN RUTTER MASTERCARD 22/04/2022 TO 23/05/2022   | 1         |            | 605.54    |
| INV B RUTT13/07/2022  |            | BANKWEST                                     | BRENDAN RUTTER MASTERCARD 22/04/2022 TO 23/05/2022   | 1         | 605.54     |           |
| DD18040.1             | 13/07/2022 | BANKWEST                                     | BRENDAN RUTTER MASTERCARD 22/04/2022 TO 23/05/2022   | 1         |            | -605.54   |
| INV B RUTT13/07/2022  |            | BANKWEST                                     | BRENDAN RUTTER MASTERCARD 22/04/2022 TO 23/05/2022   | 1         | -605.54    |           |
| DD18054.1             | 01/07/2022 | TENNANT AUSTRALIA                            | RECREATION CENTRE LEASE FEE CLEANING EQUIPMENT JULY 2022 FINANCE & LEASE IW8119996100                      | 1         |            | 573.75    |
| INV JULY 2001/07/2022 |            | TENNANT AUSTRALIA                            | RECREATION CENTRE LEASE FEE CLEANING EQUIPMENT JULY 2022 FINANCE & LEASE IW8119996100                      | 1         | 573.75     |           |
| DD18065.1             | 05/07/2022 | AWARE SUPER                                  | PAYROLL DEDUCTIONS   | 1         |            | 29,157.58 |
| INV SUPER 05/07/2022  |            | AWARE SUPER                                  | SUPERANNUATION CONTRIBUTIONS   | 1         | 24,654.64  |           |

Date: 01/08/2022  
Time: 9:17:37AM

Shire of Northam

USER: Louise Harris  
PAGE: 61 13

| Cheque /EFT No | Date       | Name   | Invoice Description          | Bank Code | INV Amount | Amount   |
|----------------|------------|--|------------------------------|-----------|------------|----------|
| INV DEDUC      | 05/07/2022 | AWARE SUPER                                  | PAYROLL DEDUCTIONS           | 1         | 2,824.89   |          |
| INV DEDUC      | 05/07/2022 | AWARE SUPER                                  | PAYROLL DEDUCTIONS           | 1         | 40.40      |          |
| INV DEDUC      | 05/07/2022 | AWARE SUPER                                  | PAYROLL DEDUCTIONS           | 1         | 40.40      |          |
| INV DEDUC      | 05/07/2022 | AWARE SUPER                                  | PAYROLL DEDUCTIONS           | 1         | 25.00      |          |
| INV DEDUC      | 05/07/2022 | AWARE SUPER                                  | PAYROLL DEDUCTIONS           | 1         | 1,100.00   |          |
| INV DEDUC      | 05/07/2022 | AWARE SUPER                                  | PAYROLL DEDUCTIONS           | 1         | 84.69      |          |
| INV DEDUC      | 05/07/2022 | AWARE SUPER                                  | PAYROLL DEDUCTIONS           | 1         | 146.88     |          |
| INV DEDUC      | 05/07/2022 | AWARE SUPER                                  | PAYROLL DEDUCTIONS           | 1         | 67.31      |          |
| INV DEDUC      | 05/07/2022 | AWARE SUPER                                  | PAYROLL DEDUCTIONS           | 1         | 102.37     |          |
| INV DEDUC      | 05/07/2022 | AWARE SUPER                                  | PAYROLL DEDUCTIONS           | 1         | 71.00      |          |
| DD18065.2      | 05/07/2022 | ONEPATH                                      | SUPERANNUATION CONTRIBUTIONS | 1         |            | 278.76   |
| INV SUPER      | 05/07/2022 | ONEPATH                                      | SUPERANNUATION CONTRIBUTIONS | 1         | 278.76     |          |
| DD18065.3      | 05/07/2022 | UNISUPER                                     | PAYROLL DEDUCTIONS           | 1         |            | 1,297.69 |
| INV SUPER      | 05/07/2022 | UNISUPER                                     | SUPERANNUATION CONTRIBUTIONS | 1         | 668.15     |          |
| INV DEDUC      | 05/07/2022 | UNISUPER                                     | PAYROLL DEDUCTIONS           | 1         | 169.54     |          |
| INV DEDUC      | 05/07/2022 | UNISUPER                                     | PAYROLL DEDUCTIONS           | 1         | 460.00     |          |
| DD18065.4      | 05/07/2022 | THE TRUSTEE FOR A E & DL WILLIAMS SUPER FUND | SUPERANNUATION CONTRIBUTIONS | 1         |            | 204.51   |
| INV SUPER      | 05/07/2022 | THE TRUSTEE FOR A E & DL WILLIAMS SUPER FUND | SUPERANNUATION CONTRIBUTIONS | 1         | 204.51     |          |
| DD18065.5      | 05/07/2022 | PLUM SUPERANNUATION FUND                     | PAYROLL DEDUCTIONS           | 1         |            | 536.56   |
| INV SUPER      | 05/07/2022 | PLUM SUPERANNUATION FUND                     | SUPERANNUATION CONTRIBUTIONS | 1         | 405.69     |          |
| INV DEDUC      | 05/07/2022 | PLUM SUPERANNUATION FUND                     | PAYROLL DEDUCTIONS           | 1         | 130.87     |          |
| DD18065.6      | 05/07/2022 | COLONIAL FIRST STATE SUPERANNUATION          | SUPERANNUATION CONTRIBUTIONS | 1         |            | 253.50   |

Ordinary Council Meeting Agenda  
17 August 2022



Date: 01/08/2022  
Time: 9:17:37AM

Shire of Northam

USER: Louise Harris  
PAGE: 62 10

| Cheque /EFT No | Date       | Name  | Invoice Description                                 | Bank Code | INV Amount | Amount    |
|----------------|------------|---|---|-----------|------------|-----------|
| INV SUPER      | 05/07/2022 | COLONIAL FIRST STATE SUPERANNUATION                 | SUPERANNUATION CONTRIBUTIONS                        | 1         | 253.50     |           |
| DD18065.7      | 05/07/2022 | HESTA SUPER FUND                                    | SUPERANNUATION CONTRIBUTIONS                        | 1         |            | 471.83    |
| INV SUPER      | 05/07/2022 | HESTA SUPER FUND                                    | SUPERANNUATION CONTRIBUTIONS                        | 1         | 471.83     |           |
| DD18065.8      | 05/07/2022 | CATHOLIC SUPER                                      | SUPERANNUATION CONTRIBUTIONS                        | 1         |            | 130.32    |
| INV SUPER      | 05/07/2022 | CATHOLIC SUPER                                      | SUPERANNUATION CONTRIBUTIONS                        | 1         | 130.32     |           |
| DD18065.9      | 05/07/2022 | AUSTRALIAN CATHOLIC SUPPERANNUATION RETIREMENT FUND | SUPERANNUATION CONTRIBUTIONS                        | 1         |            | 366.91    |
| INV SUPER      | 05/07/2022 | AUSTRALIAN CATHOLIC SUPPERANNUATION RETIREMENT FUND | SUPERANNUATION CONTRIBUTIONS                        | 1         | 366.91     |           |
| DD18090.1      | 12/07/2022 | BANKWEST  | JASON WHITEAKER MASTERCARD 24/05/2022 TO 22/06/2022 | 1         |            | 5,290.52  |
| INV B RUTT     | 12/07/2022 | BANKWEST  | ERENDAN RUTTER MASTERCARD 24/05/22 TO 22/06/22      | 1         | 79.05      |           |
| INV S PATTE    | 12/07/2022 | BANKWEST  | SCOTT PATTERSON MASTERCARD 24/05/22 TO 22/06/22     | 1         | 159.00     |           |
| INV J METC     | 12/07/2022 | BANKWEST  | JOANNE METCALF MASTERCARD 24/05/22 TO 22/06/22      | 1         | 2,091.99   |           |
| INV C YOU      | 12/07/2022 | BANKWEST  | COLIN YOUNG MASTERCARD 24/05/2022 TO 22/06/2022     | 1         | 2,045.98   |           |
| INV C HUNT     | 12/07/2022 | BANKWEST  | CHADD HUNT MASTER CARD 24/05/2022 TO 22/06/2022     | 1         | 239.00     |           |
| INV J WHIT     | 12/07/2022 | BANKWEST  | JASON WHITEAKER MASTERCARD 24/05/2022 TO 22/06/2022 | 1         | 675.50     |           |
| DD18124.1      | 19/07/2022 | AWARE SUPER   | PAYROLL DEDUCTIONS                                  | 1         |            | 28,373.60 |
| INV SUPER      | 19/07/2022 | AWARE SUPER   | SUPERANNUATION CONTRIBUTIONS                        | 1         | 23,604.43  |           |
| INV DEDUC      | 19/07/2022 | AWARE SUPER   | PAYROLL DEDUCTIONS                                  | 1         | 2,741.98   |           |
| INV DEDUC      | 19/07/2022 | AWARE SUPER   | PAYROLL DEDUCTIONS                                  | 1         | 41.09      |           |
| INV DEDUC      | 19/07/2022 | AWARE SUPER   | PAYROLL DEDUCTIONS                                  | 1         | 41.09      |           |
| INV DEDUC      | 19/07/2022 | AWARE SUPER   | PAYROLL DEDUCTIONS                                  | 1         | 25.00      |           |
| INV DEDUC      | 19/07/2022 | AWARE SUPER   | PAYROLL DEDUCTIONS                                  | 1         | 1,400.00   |           |
| INV DEDUC      | 19/07/2022 | AWARE SUPER   | PAYROLL DEDUCTIONS                                  | 1         | 99.29      |           |



Date: 01/08/2022  
Time: 9:17:37AM

Shire of Northam

USER: Louise Harris  
PAGE: 63 13

| Cheque /EFT<br>No | Date       | Name  | Invoice Description          | Bank<br>Code | INV<br>Amount | Amount   |
|-------------------|------------|---|------------------------------|--------------|---------------|----------|
| INV DEDUC         | 19/07/2022 | AWARE SUPER                                     | PAYROLL DEDUCTIONS           | 1            | 208.40        |          |
| INV DEDUC         | 19/07/2022 | AWARE SUPER                                     | PAYROLL DEDUCTIONS           | 1            | 67.31         |          |
| INV DEDUC         | 19/07/2022 | AWARE SUPER                                     | PAYROLL DEDUCTIONS           | 1            | 114.13        |          |
| INV DEDUC         | 19/07/2022 | AWARE SUPER                                     | PAYROLL DEDUCTIONS           | 1            | 30.88         |          |
| DD18124.2         | 19/07/2022 | ONEPATH   | SUPERANNUATION CONTRIBUTIONS | 1            |               | 276.42   |
| INV SUPER         | 19/07/2022 | ONEPATH   | SUPERANNUATION CONTRIBUTIONS | 1            | 276.42        |          |
| DD18124.3         | 19/07/2022 | UNISUPER  | PAYROLL DEDUCTIONS           | 1            |               | 1,143.24 |
| INV SUPER         | 19/07/2022 | UNISUPER  | SUPERANNUATION CONTRIBUTIONS | 1            | 501.04        |          |
| INV DEDUC         | 19/07/2022 | UNISUPER  | PAYROLL DEDUCTIONS           | 1            | 182.20        |          |
| INV DEDUC         | 19/07/2022 | UNISUPER  | PAYROLL DEDUCTIONS           | 1            | 460.00        |          |
| DD18124.4         | 19/07/2022 | THE TRUSTEE FOR A E & DL WILLIAMS<br>SUPER FUND | SUPERANNUATION CONTRIBUTIONS | 1            |               | 235.15   |
| INV SUPER         | 19/07/2022 | THE TRUSTEE FOR A E & DL WILLIAMS<br>SUPER FUND | SUPERANNUATION CONTRIBUTIONS | 1            | 235.15        |          |
| DD18124.5         | 19/07/2022 | PLUM SUPERANNUATION FUND                        | PAYROLL DEDUCTIONS           | 1            |               | 529.07   |
| INV SUPER         | 19/07/2022 | PLUM SUPERANNUATION FUND                        | SUPERANNUATION CONTRIBUTIONS | 1            | 400.03        |          |
| INV DEDUC         | 19/07/2022 | PLUM SUPERANNUATION FUND                        | PAYROLL DEDUCTIONS           | 1            | 129.04        |          |
| DD18124.6         | 19/07/2022 | COLONIAL FIRST STATE SUPERANNUATION             | SUPERANNUATION CONTRIBUTIONS | 1            |               | 253.50   |
| INV SUPER         | 19/07/2022 | COLONIAL FIRST STATE SUPERANNUATION             | SUPERANNUATION CONTRIBUTIONS | 1            | 253.50        |          |
| DD18124.7         | 19/07/2022 | HESTA SUPER FUND                                | SUPERANNUATION CONTRIBUTIONS | 1            |               | 483.94   |
| INV SUPER         | 19/07/2022 | HESTA SUPER FUND                                | SUPERANNUATION CONTRIBUTIONS | 1            | 483.94        |          |
| DD18124.8         | 19/07/2022 | CATHOLIC SUPER                                  | SUPERANNUATION CONTRIBUTIONS | 1            |               | 155.87   |
| INV SUPER         | 19/07/2022 | CATHOLIC SUPER                                  | SUPERANNUATION CONTRIBUTIONS | 1            | 155.87        |          |

Date: 01/08/2022  
Time: 9:17:37AM

Shire of Northam

USER: Louise Harris  
PAGE: 64 10

| Cheque /EFT No | Date       | Name   | Invoice Description          | Bank Code | INV Amount | Amount   |
|----------------|------------|--|------------------------------|-----------|------------|----------|
| DD18124.9      | 19/07/2022 | AUSTRALIAN CATHOLIC SUPERANNUATION RETIREMENT FUND | SUPERANNUATION CONTRIBUTIONS | 1         |            | 370.51   |
| INV SUPER      | 19/07/2022 | AUSTRALIAN CATHOLIC SUPERANNUATION RETIREMENT FUND | SUPERANNUATION CONTRIBUTIONS | 1         | 370.51     |          |
| DD18138.1      | 25/07/2022 | AWARE SUPER  | SUPERANNUATION CONTRIBUTIONS | 1         |            | 385.49   |
| INV SUPER      | 02/08/2022 | AWARE SUPER  | SUPERANNUATION CONTRIBUTIONS | 1         | 385.49     |          |
| DD18065.10     | 05/07/2022 | QSUPER   | SUPERANNUATION CONTRIBUTIONS | 1         |            | 225.25   |
| INV SUPER      | 05/07/2022 | QSUPER   | SUPERANNUATION CONTRIBUTIONS | 1         | 225.25     |          |
| DD18065.11     | 05/07/2022 | MEDIA SUPER  | PAYROLL DEDUCTIONS           | 1         |            | 1,194.90 |
| INV SUPER      | 05/07/2022 | MEDIA SUPER  | SUPERANNUATION CONTRIBUTIONS | 1         | 876.26     |          |
| INV DEDUC      | 05/07/2022 | MEDIA SUPER  | PAYROLL DEDUCTIONS           | 1         | 318.64     |          |
| DD18065.12     | 05/07/2022 | AUSTRALIAN SUPER PTY LTD                           | PAYROLL DEDUCTIONS           | 1         |            | 2,763.65 |
| INV SUPER      | 05/07/2022 | AUSTRALIAN SUPER PTY LTD                           | SUPERANNUATION CONTRIBUTIONS | 1         | 2,606.34   |          |
| INV DEDUC      | 05/07/2022 | AUSTRALIAN SUPER PTY LTD                           | PAYROLL DEDUCTIONS           | 1         | 139.78     |          |
| INV DEDUC      | 05/07/2022 | AUSTRALIAN SUPER PTY LTD                           | PAYROLL DEDUCTIONS           | 1         | 17.53      |          |
| DD18065.13     | 05/07/2022 | ANZ SMART CHOICE SUPER (ONEPATH MASTERFUND)        | SUPERANNUATION CONTRIBUTIONS | 1         |            | 263.22   |
| INV SUPER      | 05/07/2022 | ANZ SMART CHOICE SUPER (ONEPATH MASTERFUND)        | SUPERANNUATION CONTRIBUTIONS | 1         | 263.22     |          |
| DD18065.14     | 05/07/2022 | AUSTRALIAN RETIREMENT TRUST                        | SUPERANNUATION CONTRIBUTIONS | 1         |            | 153.01   |
| INV SUPER      | 05/07/2022 | AUSTRALIAN RETIREMENT TRUST                        | SUPERANNUATION CONTRIBUTIONS | 1         | 153.01     |          |
| DD18065.15     | 05/07/2022 | YKC SUPERFUND                                      | PAYROLL DEDUCTIONS           | 1         |            | 865.39   |
| INV SUPER      | 05/07/2022 | YKC SUPERFUND                                      | SUPERANNUATION CONTRIBUTIONS | 1         | 634.62     |          |
| INV DEDUC      | 05/07/2022 | YKC SUPERFUND                                      | PAYROLL DEDUCTIONS           | 1         | 230.77     |          |
| DD18065.16     | 05/07/2022 | MACQUARIE SUPER CONSOLIDATOR                       | SUPERANNUATION CONTRIBUTIONS | 1         |            | 196.79   |

Date: 01/08/2022  
Time: 9:17:37AM

Shire of Northam

USER: Louise Harris  
PAGE: 65 13

| Cheque /EFT<br>No | Date       | Name                         | Invoice Description          | Bank<br>Code | INV<br>Amount | Amount   |
|-------------------|------------|------------------------------|------------------------------|--------------|---------------|----------|
| INV SUPER         | 05/07/2022 | MACQUARIE SUPER CONSOLIDATOR | SUPERANNUATION CONTRIBUTIONS | 1            | 196.79        |          |
| DD18065.17        | 05/07/2022 | ZURICH AUSTRALIA LIMITED     | PAYROLL DEDUCTIONS           | 1            |               | 662.52   |
| INV SUPER         | 05/07/2022 | ZURICH AUSTRALIA LIMITED     | SUPERANNUATION CONTRIBUTIONS | 1            | 485.85        |          |
| INV DEDUC         | 05/07/2022 | ZURICH AUSTRALIA LIMITED     | PAYROLL DEDUCTIONS           | 1            | 176.67        |          |
| DD18065.18        | 05/07/2022 | REST INDUSTRY SUPER          | SUPERANNUATION CONTRIBUTIONS | 1            |               | 1,320.00 |
| INV DEDUC         | 05/07/2022 | REST INDUSTRY SUPER          | PAYROLL DEDUCTIONS           | 1            | 287.45        |          |
| INV SUPER         | 05/07/2022 | REST INDUSTRY SUPER          | SUPERANNUATION CONTRIBUTIONS | 1            | 1,032.55      |          |
| DD18065.19        | 05/07/2022 | PRIME SUPER                  | SUPERANNUATION CONTRIBUTIONS | 1            |               | 527.06   |
| INV DEDUC         | 05/07/2022 | PRIME SUPER                  | PAYROLL DEDUCTIONS           | 1            | 140.55        |          |
| INV SUPER         | 05/07/2022 | PRIME SUPER                  | SUPERANNUATION CONTRIBUTIONS | 1            | 386.51        |          |
| DD18065.20        | 05/07/2022 | NETWEALTH SUPERANNUATION     | SUPERANNUATION CONTRIBUTIONS | 1            |               | 312.62   |
| INV SUPER         | 05/07/2022 | NETWEALTH SUPERANNUATION     | SUPERANNUATION CONTRIBUTIONS | 1            | 312.62        |          |
| DD18065.21        | 05/07/2022 | HSTPLUS SUPER                | SUPERANNUATION CONTRIBUTIONS | 1            |               | 564.64   |
| INV DEDUC         | 05/07/2022 | HSTPLUS SUPER                | PAYROLL DEDUCTIONS           | 1            | 50.00         |          |
| INV SUPER         | 05/07/2022 | HSTPLUS SUPER                | SUPERANNUATION CONTRIBUTIONS | 1            | 514.64        |          |
| DD18065.22        | 05/07/2022 | SUNSUPER                     | SUPERANNUATION CONTRIBUTIONS | 1            |               | 235.08   |
| INV SUPER         | 05/07/2022 | SUNSUPER                     | SUPERANNUATION CONTRIBUTIONS | 1            | 235.08        |          |
| DD18065.23        | 05/07/2022 | AMP LIFE LIMITED             | SUPERANNUATION CONTRIBUTIONS | 1            |               | 230.55   |
| INV SUPER         | 05/07/2022 | AMP LIFE LIMITED             | SUPERANNUATION CONTRIBUTIONS | 1            | 230.55        |          |
| DD18124.10        | 19/07/2022 | QSUPER                       | SUPERANNUATION CONTRIBUTIONS | 1            |               | 234.07   |
| INV SUPER         | 19/07/2022 | QSUPER                       | SUPERANNUATION CONTRIBUTIONS | 1            | 234.07        |          |
| DD18124.11        | 19/07/2022 | MEDIA SUPER                  | PAYROLL DEDUCTIONS           | 1            |               | 1,194.90 |

Date: 01/08/2022  
Time: 9:17:37AM

Shire of Northam

USER: Louise Harris  
PAGE: 66 10

| Cheque /EFT No | Date       | Name  | Invoice Description          | Bank Code | INV Amount | Amount   |
|----------------|------------|---|------------------------------|-----------|------------|----------|
| INV SUPER      | 19/07/2022 | MEDIA SUPER                                 | SUPERANNUATION CONTRIBUTIONS | 1         | 876.26     |          |
| INV DEDUC      | 19/07/2022 | MEDIA SUPER                                 | PAYROLL DEDUCTIONS           | 1         | 318.64     |          |
| DD18124.12     | 19/07/2022 | AUSTRALIAN SUPER PTY LTD                    | PAYROLL DEDUCTIONS           | 1         |            | 4,977.35 |
| INV SUPER      | 19/07/2022 | AUSTRALIAN SUPER PTY LTD                    | SUPERANNUATION CONTRIBUTIONS | 1         | 4,504.79   |          |
| INV DEDUC      | 19/07/2022 | AUSTRALIAN SUPER PTY LTD                    | PAYROLL DEDUCTIONS           | 1         | 367.38     |          |
| INV DEDUC      | 19/07/2022 | AUSTRALIAN SUPER PTY LTD                    | PAYROLL DEDUCTIONS           | 1         | 105.18     |          |
| DD18124.13     | 19/07/2022 | ANZ SMART CHOICE SUPER (ONEPATH MASTERFUND) | SUPERANNUATION CONTRIBUTIONS | 1         |            | 267.18   |
| INV SUPER      | 19/07/2022 | ANZ SMART CHOICE SUPER (ONEPATH MASTERFUND) | SUPERANNUATION CONTRIBUTIONS | 1         | 267.18     |          |
| DD18124.14     | 19/07/2022 | AUSTRALIAN RETIREMENT TRUST                 | SUPERANNUATION CONTRIBUTIONS | 1         |            | 207.88   |
| INV SUPER      | 19/07/2022 | AUSTRALIAN RETIREMENT TRUST                 | SUPERANNUATION CONTRIBUTIONS | 1         | 207.88     |          |
| DD18124.15     | 19/07/2022 | YKC SUPERFUND                               | PAYROLL DEDUCTIONS           | 1         |            | 865.39   |
| INV SUPER      | 19/07/2022 | YKC SUPERFUND                               | SUPERANNUATION CONTRIBUTIONS | 1         | 634.62     |          |
| INV DEDUC      | 19/07/2022 | YKC SUPERFUND                               | PAYROLL DEDUCTIONS           | 1         | 230.77     |          |
| DD18124.16     | 19/07/2022 | MACQUARIE SUPER CONSOLIDATOR                | SUPERANNUATION CONTRIBUTIONS | 1         |            | 253.50   |
| INV SUPER      | 19/07/2022 | MACQUARIE SUPER CONSOLIDATOR                | SUPERANNUATION CONTRIBUTIONS | 1         | 253.50     |          |
| DD18124.17     | 19/07/2022 | ZURICH AUSTRALIA LIMITED                    | PAYROLL DEDUCTIONS           | 1         |            | 724.19   |
| INV SUPER      | 19/07/2022 | ZURICH AUSTRALIA LIMITED                    | SUPERANNUATION CONTRIBUTIONS | 1         | 531.07     |          |
| INV DEDUC      | 19/07/2022 | ZURICH AUSTRALIA LIMITED                    | PAYROLL DEDUCTIONS           | 1         | 193.12     |          |
| DD18124.18     | 19/07/2022 | REST INDUSTRY SUPER                         | SUPERANNUATION CONTRIBUTIONS | 1         |            | 1,360.79 |
| INV DEDUC      | 19/07/2022 | REST INDUSTRY SUPER                         | PAYROLL DEDUCTIONS           | 1         | 298.33     |          |
| INV SUPER      | 19/07/2022 | REST INDUSTRY SUPER                         | SUPERANNUATION CONTRIBUTIONS | 1         | 1,062.46   |          |

Date: 01/08/2022  
 Time: 9:17:37AM

Shire of Northam

USER: Louise Harris  
 PAGE: 67 13

| Cheque /EFT<br>No | Date       | Name                     | Invoice Description          | Bank<br>Code | INV<br>Amount | Amount |
|-------------------|------------|--------------------------|------------------------------|--------------|---------------|--------|
| DD18124.19        | 19/07/2022 | PRIME SUPER              | SUPERANNUATION CONTRIBUTIONS | 1            |               | 543.26 |
| INV DEDUC         | 19/07/2022 | PRIME SUPER              | PAYROLL DEDUCTIONS           | 1            | 144.87        |        |
| INV SUPER         | 19/07/2022 | PRIME SUPER              | SUPERANNUATION CONTRIBUTIONS | 1            | 398.39        |        |
| DD18124.20        | 19/07/2022 | NETWEALTH SUPERANNUATION | SUPERANNUATION CONTRIBUTIONS | 1            |               | 312.62 |
| INV SUPER         | 19/07/2022 | NETWEALTH SUPERANNUATION | SUPERANNUATION CONTRIBUTIONS | 1            | 312.62        |        |
| DD18124.21        | 19/07/2022 | HOSTPLUS SUPER           | SUPERANNUATION CONTRIBUTIONS | 1            |               | 571.57 |
| INV DEDUC         | 19/07/2022 | HOSTPLUS SUPER           | PAYROLL DEDUCTIONS           | 1            | 50.00         |        |
| INV SUPER         | 19/07/2022 | HOSTPLUS SUPER           | SUPERANNUATION CONTRIBUTIONS | 1            | 521.57        |        |
| DD18124.22        | 19/07/2022 | SUNSUPER                 | SUPERANNUATION CONTRIBUTIONS | 1            |               | 214.97 |
| INV SUPER         | 19/07/2022 | SUNSUPER                 | SUPERANNUATION CONTRIBUTIONS | 1            | 214.97        |        |
| DD18124.23        | 19/07/2022 | AMP LIFE LIMITED         | SUPERANNUATION CONTRIBUTIONS | 1            |               | 230.15 |
| INV SUPER         | 19/07/2022 | AMP LIFE LIMITED         | SUPERANNUATION CONTRIBUTIONS | 1            | 230.15        |        |

**REPORT TOTALS**

| Bank Code    | Bank Name | TOTAL               |
|--------------|-----------|---------------------|
| 1            | MUNIFUND  | 2,049,564.92        |
| <b>TOTAL</b> |           | <b>2,049,564.92</b> |

### Attachment 2: Declaration

#### Payment dates 1<sup>st</sup> July 2022 – 31<sup>st</sup> July 2022

- Municipal Fund payment cheque numbers 35509 to 35515 Total \$35,158.28.

#### Electronic Funds Transfer

- Municipal Fund EFT44134 to EFT44460 Total \$1,922,165.42.
- Direct Debits Total \$92,241.22.

All have been made in accordance with delegated authority reference number (M/F/F/Regs LGA 1995 S5.42).

| Month        | Cheques<br>2022/2023 | EFT Payments<br>2022/2023 | Direct Debits<br>2022/2023 | Payroll<br>2022/2023 | Total Payments<br>2022/2023 |
|--------------|----------------------|---------------------------|----------------------------|----------------------|-----------------------------|
| July         | \$ 35,158.28         | \$ 1,922,165.42           | \$ 92,241.22               | \$ 450,983.16        | \$ 2,500,548.08             |
| August       |                      |                           |                            |                      | \$ -                        |
| September    |                      |                           |                            |                      | \$ -                        |
| October      |                      |                           |                            |                      | \$ -                        |
| November     |                      |                           |                            |                      | \$ -                        |
| December     |                      |                           |                            |                      | \$ -                        |
| January      |                      |                           |                            |                      | \$ -                        |
| February     |                      |                           |                            |                      | \$ -                        |
| March        |                      |                           |                            |                      | \$ -                        |
| April        |                      |                           |                            |                      | \$ -                        |
| May          |                      |                           |                            |                      | \$ -                        |
| June         |                      |                           |                            |                      | \$ -                        |
| <b>Total</b> | <b>\$ 35,158.28</b>  | <b>\$ 1,922,165.42</b>    | <b>\$ 92,241.22</b>        | <b>\$ 450,983.16</b> | <b>\$ 2,500,548.08</b>      |

The following table presents all payments made for the month from Council credit cards paid by direct debit DD18090.1 - \$5,290.52

| Summary Credit Card Payments                   | \$     | Total            |
|--|--------|------------------|
| <b>CEO</b>                                     |        |                  |
| PERSONAL PURCHASE - REFUNDED NEXT MONTH        | 500.00 |                  |
| DOMINOS NORTHAM - CATERING FOR COUNCIL MEETING | 175.50 |                  |
|  |        | <b>\$ 675.50</b> |

**Executive Manager of Community Services**

|  |        |                    |
|--|--------|--------------------|
| SQUARESPACE INC - BKB WEBSITE ANNUAL SUBSCRIPTION    | 300.00 |                    |
| HARVEY NORTHAM - CRICUT CUTTING MACHINE AND TOOLS    | 468.00 |                    |
| COLES - BKB NATIONAL RECONCILIATION                  | 149.26 |                    |
| CRIME CHECK AUSTRALIA - DONNA MOODY CLEARANCE        | 99.00  |                    |
| CRIME CHECK AUSTRALIA - JULIE WYNNE CLEARANCE        | 99.00  |                    |
| FACEBOOK - JOB AD- BKB MANAGER                       | 539.53 |                    |
| BETTA HOME AND LIVING NORTHAM - CREATE 298 KETTLE    | 109.00 |                    |
| <br>   |        |                    |
| DOMINOS NORTHAM - PIZZA REC CENTRE                   | 122.00 |                    |
| DOMINOS NORTHAM - PIZZA REC CENTRE                   | 96.85  |                    |
| DOME NORTHAM - JO & JASON COFFEE WITH SUPERINTENDENT | 15.20  |                    |
| DOMINOS NORTHAM - PIZZA REC CENTRE                   | 94.15  |                    |
|  |        | <b>\$ 2,091.99</b> |

**Executive Manager of Corporate Services**

|   |         |                    |
|---|---------|--------------------|
| CPP CONVENTION CENTRE - FINANCIAL REPORT WORKSHOP (PARKING) | 23.22   |                    |
| AMAYSIM MOBILE PTY LTD - LIBRARY LIFT PHONE DATA            | 10.00   |                    |
| ADOBE ID CREATIVE CLOUD - MONTHLY FEES                      | 213.99  |                    |
| SOFTWARE MART AUS - WINDOWS LICENCE KEYS * 15               | 550.00  |                    |
| CLASSIC IT SUPPORT - SSD HARD DRIVES * 15                   | 1125.00 |                    |
| CREDIT CARD FOREIGN TRANSACTION FEE                         | 123.77  |                    |
|   |         | <b>\$ 2,045.98</b> |

**Executive Manager of Development Services**

|  |        |                  |
|--|--------|------------------|
| SOFTWARE MART AUS - WINDOWS 10 LICENCES KEYS X 5 | 200.00 |                  |
| CREDIT CARD - ANNUAL FEE                         | 39.00  |                  |
|  |        | <b>\$ 239.00</b> |

**Executive Manager of Engineering Services**

|  |        |                  |
|--|--------|------------------|
| RLSSWA - POOL LIFE GAURD REQUALIFICATION - DAVID EMERY | 159.00 |                  |
|  |        | <b>\$ 159.00</b> |

**Community Emergency Services Manager**

|  |       |
|--|-------|
| HOME BAKE SHOP - TRAINING REFRESHMENTS | 49.40 |
|--|-------|

|                                      |                    |
|--------------------------------------|--------------------|
| COLES - WELFARE FOR TRAINING NIGHT   | 29.65              |
|                                      | <b>\$ 79.05</b>    |
| <b>Total Credit Card Expenditure</b> | <b>\$ 5,290.52</b> |

CERTIFICATION OF THE PRESIDENT

I hereby certify that this schedule of account covering vouchers and electronic fund transfer payments as per above and totalling \$2,500,548.08 was submitted to the Ordinary Meeting of Council on Wednesday, 17 August 2022.

\_\_\_\_\_ CERTIFICATION OF THE PRESIDENT

CERTIFICATE OF THE CHIEF EXECUTIVE OFFICER

This schedule of accounts paid covering vouchers \$2,500,548.08 was submitted to each member of the Council on Wednesday, 17 August 2022, has been checked and is fully supported by vouchers and invoices which are submitted herewith, and which have been duly certified as to the receipt of goods and the rendition of services and as to prices, computations and casting and the amounts shown are due for payment.

\_\_\_\_\_ CHIEF EXECUTIVE OFFICER



## 13.5 COMMUNITY SERVICES

### 13.5.1 Nyoongar Cultural Advisory Group

|   |  |
|---|--|
| <b>File Reference:</b>                  | 2.1.3.8  |
| <b>Reporting Officer:</b>               | Cheryl Greenough, Manager Bilya Koort Boodja     |
| <b>Responsible Officer:</b>             | Jo Metcalf, Executive Manager Community Services |
| <b>Officer Declaration of Interest:</b> | Nil  |
| <b>Voting Requirement:</b>              | Simple Majority                                  |
| <b>Press release to be issued:</b>      | No   |

#### BRIEF

This report is for Council to consider the recommendations and actions from the Nyoongar Cultural Advisory Group (NCAG).

#### ATTACHMENTS

- Attachment 1: Diagram of some proposed changes.  
Attachment 2: notes from the meeting.

#### A. BACKGROUND / DETAILS

Council has had a Nyoongar Cultural Advisory Group Committee in place for some time. A report was provided to Council in July 2022 highlighting officer concern at the level of engagement from the committee. It is the officers view this disengagement has been influenced largely by the following factors

- Formal structure of the committee;
- Level of detail provided in committee agendas;
- Increased requirement for complying with standing orders and other local government frameworks, such as declarations of interest; and
- Inability for members to raise general business during the meeting.

Council resolved as follows at its July 2022 meeting

#### RECOMMENDATION #2

**That Council:**

- 1. Direct the Chief Executive Officer to establish a Nyoongar Cultural Advisory Group.**
- 2. Advisory Group membership to include a representative of the following families:**
  - a. Ryder**

- b. **Garlett**
  - c. **Stack**
  - d. **Slater**
  - e. **McGuire**
  - f. **Kickett**
  - g. **Moody**
  - h. **Davis**
  - i. **Any other family groups as agreed by majority of the above-mentioned families**
3. **Matters to be discussed at the Group meetings to include**
- a. **Bilya Koort Boodja operations**
  - b. **Matters raised by the Shire of Northam pertaining to aboriginal culture**
  - c. **Matters raised by working group**
4. **Direct the Chief Executive Officer to provide a report to Full Council outlining discussions held at the working group meetings and making any recommendations to Council as deemed appropriate.**

The newly formed working group has now held its first meeting, the subject of this item is to report to Council the outcomes and items for discussion at the meeting.

## **B. CONSIDERATIONS**

### **B.1 Strategic Community / Corporate Business Plan**

Theme Area 1: Economic Growth.

Outcome 4.2: Northam honours, and is recognised for, its unique heritage and cultural identity.

Objectives:

There is a strong, respected and valued Aboriginal community and culture in the Shire of Northam

### **B.2 Financial / Resource Implications**

TBA – Possible costs for Elder attendance.

Possible costs for alterations to exhibition space.

### **B.3 Legislative Compliance**

Nil.

### **B.4 Policy Implications**

Nil.

### **B.5 Stakeholder Engagement / Consultation**

Advisory Group consultation.

### **B.6 Risk Implications**

| Risk Category        | Description   | Rating<br>(likelihood x<br>consequence)        | Mitigation Action   |
|----------------------|---|--|---|
| Financial            | Without the Advisory Group and Elder input the BKB could suffer financially | Possible (3) x<br>Medium (3) =<br>Moderate (9) | Ensure continuity in working with the Elders and Advisory Group |
| Health & Safety      | Nil   |  |   |
| Reputation           |   |  |   |
| Service Interruption | Nil   |  |   |
| Compliance           |   |  |   |
| Property             |   |  |   |
| Environment          |   |  |   |

### B.7 Natural Environment Considerations

N/A.

### C. OFFICER'S COMMENT

The Advisory Group meetings are structured into three sections, which will form the structure of reporting to Council.

The following people were in attendance:

- Cr. Attila Mencshelyi – Councillor, Shire of Northam
- Jason Whiteaker – CEO, Shire of Northam
- Cheryl Greenough - BKB Centre Manager
- Jaime Hawkins – Community Development Officer, Shire of Northam
- Kathy Davis – Elder
- Liz Stack – Stack family representative
- Shirley Slater – Slater family representative
- Donna Moody – Moody family representative
- Brenda DeAtta – Other Nyoongar representative

Brenda DeAtta did an acknowledgement to country. It was agreed either a welcome or acknowledgment to country should be done at the start of each meeting.

Bilya Koort Boodja operations

- i. Welcome provided to Cheryl Greenough as the new Centre Manager. Cheryl provided a background on herself to the working group, including her heritage as a Koori woman. All family representatives extended a strong welcome to Cheryl.

- ii. Discussion around opening hours. It was agreed that it would be a positive outcome to have the centre hours of opening put back to 9am to 4pm, acknowledging the staff issues the Centre has experienced.
- iii. Cheryl provided an update on the renewal works which are being undertaken in the BKB exhibition space. The group decided to do a walk through with Cheryl to gain a better understanding of the upgrades and provide some input;
  - The text on the wall at the entry to "Welcome to Country" is too small and needs to be enlarged
  - The quote on the wall by Veronica McGuire is not to be changed.
  - The map on the wall as you exit Welcome to Country is too small and should be enlarged to show the entire Nyoongar Nation.
  - QR codes should be incorporated into the map table to allow more immersive interaction and to provide viewers with coordinates/directions to look at landmarks on country.
  - Allow a drone to take pictures to identify the landscapes shown on the map table and obtain Nyoongar names for the landscapes. Jermaine Davis from WNRM may already have suitable photos.
  - The suggested Wargyl trail on the map table should depict a serpent with bright colours.
  - More stories are to be collected from Ballardong people outside of the Northam area so the centre is more inclusive of all Ballardong.
  - Two of the season names are spelt in the Whadjuk spelling, can these be changed to the Ballardong spelling.
  - There will also be a pictorial display of a burning Balga tree.
- iv. There were discussions around the use of the meeting rooms. It was agreed that the meeting rooms should be made available to anyone, however there should be a condition for attendees to receive a welcome to country or be required to make an acknowledgement to country and also go through the BKB interpretive centre. The desire of the group was that anyone using the building should leave more culturally aware.

Matters raised by the Shire of Northam pertaining to aboriginal culture:

- i. It was discussed that more family names should be included in the Advisory Group with the possibility of proxies being included in the event one of the families cannot be represented on that day.

Valery and Rod Garlett were to be approached to attend as Kirk Garlett is often not available. Others families to be approached to

- attend are the Winmar family, Yvonne Kickett can represent the Winmar family and the Yarran family, Michelle or Karren.
- ii. Spoke about the challenge around getting elders and family representatives to attend meeting. There was a feeling that some members were having trouble attending due to work pressures. A suggestion was made that as some of the members work, the Shire may be able to speak to employers and advise how important this meeting is so they will allow the family member to attend.
  - iii. Discussion around getting a list of people who can do welcome to country and didgeridoo playing etc. The group are to advise the names of people who can provide various services such as Welcome to Country and Didgeridoo playing to the BKB manager to ensure bookings can be fulfilled.
  - iv. Discussion around the opportunity to share cultural sites with other members of the community. Once such site is the birthing site on Katrine Road. Was agreed that places such as the birthing site could be used as tourist opportunities however we needed to be careful with cultural sensitivities for example the Birthing Site is a place for women's business and as such men are not able to attend. This being the case it may be an opportunity to do organised tours of the site at regular interval under the guidance of a local female elder.
  - v. Discussions were held about the Aboriginal Reserve and the CEO advised the Shire is working with the Aboriginal Lands Trust to resolve the issue. The attendees at the meeting indicated their desire to not have people staying at the site as it is currently a place which can not be accessed or shared by the entire community as it once was. There was support for the Shire to continue to work to address the issues currently being experienced.
  - vi. Co-naming of sites. It was agreed this was a strong desire of the committee. The first name to be agreed was for the Avon River. More information will be provided to the next meeting where a name will be agreed and recommended to Council for adoption.

Matters raised by working group:

Payments for Elders attending Advisory Group meetings was an issue raised. It was agreed that this would be put on as a dot point item for the next meeting

(Latest update post meeting) The plan for the Lullabies project participants could perform as part of the Bilya Festival cannot go ahead as key facilitators are not available on that date however a display and some of their songs will be played on CD at the VIP function.

**RECOMMENDATION**

**That Council:**

- 1. Accept the report as presented.**
- 2. That the following families be approached to attend the meetings:**
  - **Garlett family.**
  - **Winmar family.**
  - **Yarran family.**

Attachment 1

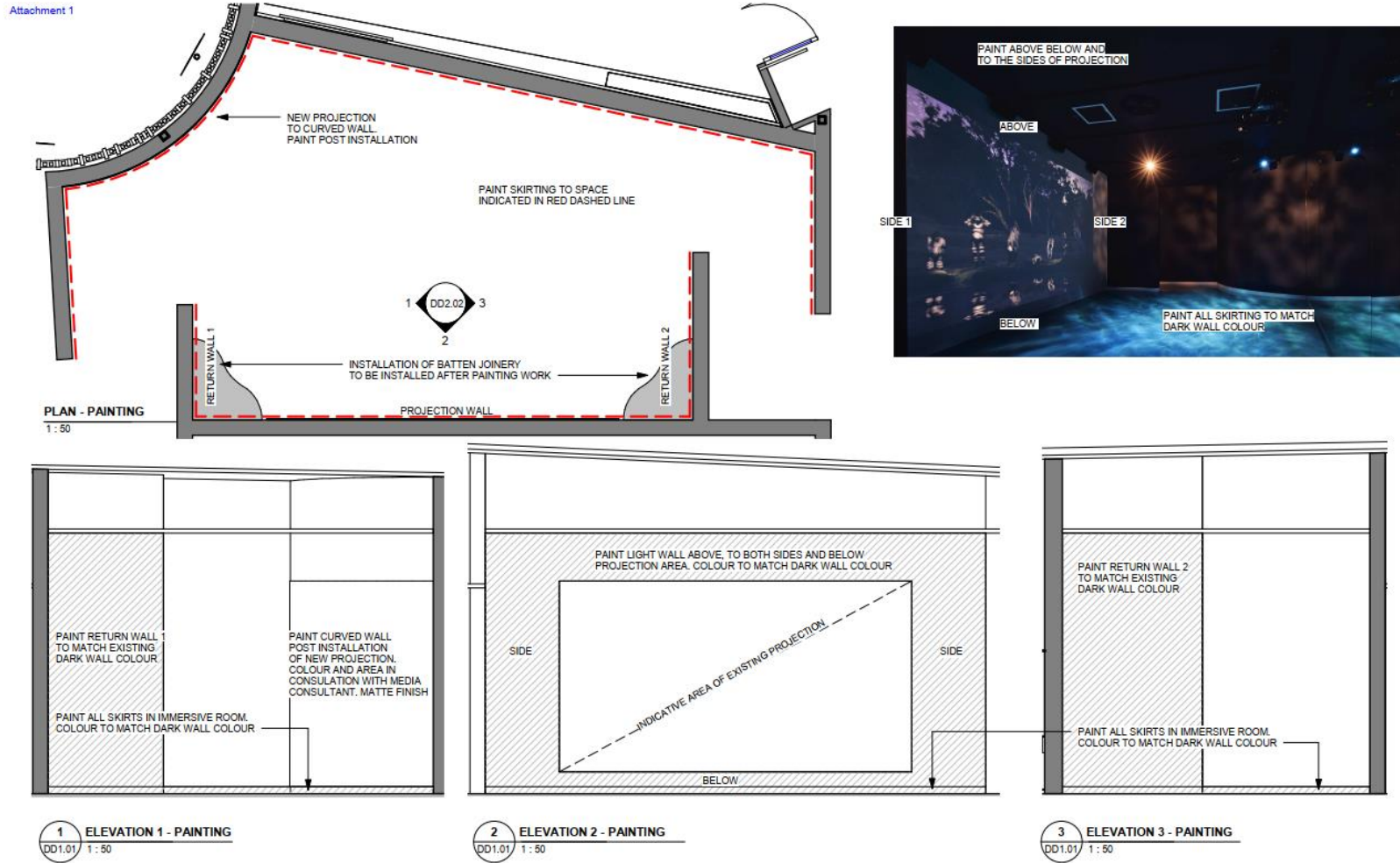

PAINTING SCOPE RESPONSIBILITY OF SHIRE OF NORTHAM. DRAWING PROVIDED AS REFERENCE



CANBERRA:  
 16 Stephens Road  
 Queanbeyan, 2620  
 P: +61 2 6299 7340  
 E: canb@thylacine.com.au

MELBOURNE:  
 T.O.J.I. 2 Place, 1 Tiroookit Ct  
 Brunswick VIC 3066  
 P: +61 3 9427 9779  
 E: melb@thylacine.com.au

REV DATE AMENDMENT  
 1 16/02/22 Information for painting

SHIRE OF NORTHAM  
 BKB Stage 2  
 D466

DRAWING NAME  
 PAINTING Immersive Space  
 AUTHOR: CW  
 CHECKED: CM

DRAWING NUMBER  
 DD2.02 - 1  
 DATE: 16/02/22  
 SCALE: 1:50



## Nyoongar Cultural Advisory Group Meeting 27 July 2022

### MINUTES

#### ATTENDANCE:

Cr. Attila Mencshelyi – Councillor, Shire of Northam  
Jason Whiteaker – CEO, Shire of Northam  
Cheryl Greenough - BKB Centre Manager  
Jaime Hawkins – Community Development Officer, Shire of Northam  
Kathy Davis – Elder  
Liz Stack – Stack family representative  
Shirley Slater – Slater family representative  
Donna Moody – Moody family representative  
Brenda De Atta – Other Nyoongar representative

#### Meeting Opened at 3:45pm

Committee update from CEO Jason Whiteaker:

- Council has disbanded the formal committee. This allows the meeting structure to be more informal. The outcomes of the advisory group meetings will still be reported to Council.

Brenda De Atta said an Acknowledgement to Country. This was initially missed. **ACTION:** Ensure that each meeting open with an Acknowledgement or Welcome to Country and 1 minutes silence for Sorry Time.

The Group observed 1 minutes silence for Sorry Time.





## Update on BKB

### Appointment of Centre Manager:

- New manager Cheryl Greenough introduced herself as a proud Koori woman from the New South Wales South Coast. She has been living in the Northam area for the past 30 years and has worked at the Shire in a governance role for the past 7 years. She is really excited to be learning about culture through the role.

### BKB opening hours:

- Kathy Davis requested the opening hours go back to being 9am – 4pm. The group agreed.
- Cheryl has been helping on weekends and will do as necessary.
- Kathy Davis said we need to work as a community to make this place work.
- **ACTION:** Kathy Davis is available to work Sundays and Liz Stack said she will be available for weekends in the summertime.

### Bilya Festival (Avon Descent):

- VIP function to be held at the BKB on 12 August. Cyndy Moody and the Northam Nyoongar Lullabies will be performing.
- A Welcome to Country will be performed at the start of the street parade.
- A large Wargal street puppet is being built and decorated by Kirk Garlett. Daniel Garlett will play the didgeridoo and his dancers will lead the Wargal which will meander through the street.
- A Blessing of the River will be performed before the race.
- **ACTION:** Jaime Hawkins to find out who is doing the Blessing of the River and inform Kathy Davis. **RESPONSE:** Daniel Garlett has been organised. Kathy informed.
- Kathy suggested that it should be Liz Stack or Shirley Slater. Liz Stack said Pat Davis should be asked first, as she was the Elder to start the tradition.

### Changes to the exhibition:

- Group agreed the text on the wall as you enter the exhibition is too small.
- The quote from Veronica McGuire cannot be changed.
- The map of Nyoongar Country is too small. The map should be enlarged and show the entire Nyoongar Nation.
- QR codes to be incorporated into the map table to allow more immersive interaction.
- Take drone pictures to identify the landscapes on the map table and obtain the Nyoongar names for them. **ACTION:** Talk to Jermaine Davis at Wheatbelt NRM, as they have photos and videos already collected.
- **ACTION:** The Wargal trail on the map table to be depicted as a serpent with bright colours.



- More stories are to be collected from Ballardong people outside of Northam, so the centre is more inclusive of all Ballardong.
- Liz Stack asked if the seasons could be changed as some of the panels contain Whadjuk spelling instead of Ballardong. **ACTION:** Cheryl to investigate.
- There is to be a representation of a burning balga stem. **ACTION:** Cheryl to clarify where this will be positioned.
- Shirley Slater shared how they would light the balga stem to make fire.

### Items for Council

Family representation on the NCAG:

- Winmar and Yarran families should be also represented. Yvonne Kickett can represent the Winmar family. **ACTION:** Karren and Michelle should be approached to represent the Yarran families.
- **ACTION:** Valerie and Rod Garlett to be approached to attend meetings. Kirk Garlett currently represents the Garlett family however, struggles to attend meetings and already contributes a lot to the community.
- Under the Committee of Council structure only one person could represent each family, under the new structure we can have more representatives.
- Donna Moody suggested that not everyone is able to get released from work to attend, so the Shire could speak to those employers to ask if they could release them for the meetings.

Who can perform Welcome to Country:

- Deborah Moody
- Pat Davis
- Liz Stack
- Shirley Slater

**ACTION:** Group to advise Cheryl if there are any others.

For the playing of the didgeridoo:

- Frank Davis
- Trevor Davis
- Daniel Garlett
- Phillip Walley Stack

Kathy Davis spoke of the Youth at Risk Group she started, she would like to see the boys taught how to make didgeridoos as well as play them. She encouraged the other group members to attend the youth at risk meetings.



#### Dual naming of the Avon River:

- **ACTION:** Liz Stack will inform Cheryl of the Ballardong name for the Avon River. It is in a book at Northam Primary School.
- Donna Moody has a story of her uncle that refers to the Nyoongar name for the Mortlock River as Ngaarin (unsure of spelling).

#### Birthing Site:

- **ACTION:** Kathy Davis requested female Shire workers conduct a clean-up of the birthing site. The weeds are overgrown. Wheatbelt NRM can provide a female ranger to accompany the Shire workers.
- Discussion about whether there is signage and if the site should be promoted. BKB can promote it and do tour groups for women, but not advertise its location as this might tempt men to go out there. There are also some men's sites behind Yongah Hill and Mt Ommaney.

#### General Discussion

- Discussion about the Aboriginal Reserve. Jason Whiteaker informed the group that the Shire is working with Aboriginal Lands Trust regarding the Reserve. It requires a whole of community approach, and he will keep the group updated on any developments.
- Shirley Slater inquired about the whereabouts of posters that were at the Visitors Centre of family trees of people that were at the Reserve. Jason Whiteaker said they were removed and put in storage out of respect after some families had issues with the information contained on them, saying it was wrong. **ACTION:** Locate the posters and bring them to the next meeting for the group to view.
- There should be conditions placed on the hire of meeting rooms for non-cultural purposes at the BKB that the hirer has to engage in some form of cultural awareness, such as a tour of the exhibition space, have Elder do a Welcome to Country etc.
- Group approve of Yolanda from Headspace attending the next meeting to yarn about having a mental health and having a professional working from the centre once a month.
- The Aboriginal Cultural Heritage Act 2021 (Dept Planning Lands and Heritage) meeting held at the BKB. They want to get Nyoongar people involved in the design of the Act. There will be another meeting held next month.
- **ACTION:** Meeting payments be included in the agenda for discussion at the next meeting.

**Meeting Closed at 5:15pm**

## 14. MATTERS BEHIND CLOSED DOORS

### RECOMMENDATION

That Council, in accordance with section 11.1(i) of the Shire of Northam Standing Orders Local Law 2018 and Section 5.23 (2) (b) (c) (d) of the Local Government Act 1995, meet behind closed doors to consider agenda items:

- 14.1 Lease of a portion of Reserve 44700 - as the matter relates to a contract which may be entered into.
- 14.2 Unauthorised Structure – A72 – as the matter relates to the personal affairs of a person and legal advice obtained or which may be obtained.

CARRIED /

### 14.1 LEASE OF A PORTION OF RESERVE 44700

*Cr J E G Williams declared a "Proximity" interest in item 14.2 – Unauthorised Structure – A72 as a property that Cr Williams co-owns is located directly across a thoroughfare from the subject property.*

### 14.2 UNAUTHORISED STRUCTURE – A72

### RECOMMENDATION

That Council move out from behind closed doors.

## 15. MOTIONS OF WHICH PREVIOUS NOTICE HAS BEEN GIVEN

### 15.1 FENCED DOG PARK

### MOTION

Moved: Cr Antonio

That Council request the Chief Executive Officer to investigate the various options and associated costs of establishing a fenced area for a dog park based on the request from ratepayers and report back to Council.

Calm Canines  
61 Wood Drive, Northam  
WA 6401  
M: 0434 078 533  
E: [ktr1965eagle@hotmail.com](mailto:ktr1965eagle@hotmail.com)

9<sup>th</sup> June 2022

Shire of Northam  
395 Fitzgerald St, Northam  
WA 6401

### **Re Fenced Dog Exercise Area in Northam**

To whom it may concern,

I am writing in support of a fully fenced dog exercise area within the Shire of Northam.

Off-leash dog parks such as Bert Hawke Oval have many benefits for dogs and their owners. They provide the opportunity for dogs to exercise, socialise with other dogs, enjoy the fresh air, practice training techniques, play games and generally race around and burn off energy.

These activities are important for physical health because they prevent problems such as obesity and joint disfunction. They also provide essential mental stimulation and prevent the development of problem behaviours such as destructiveness or excessive barking.

For owners, it's fun to meet other owners, swap tips and even make new friends.

Despite their growing popularity, off-leash dog parks are not however suitable for all dogs. To ensure that owners, their dogs and others can safely enjoy the experience of an off-leash park, there are several important considerations to keep in mind.

Off-leash parks are public areas that are not supervised by trained staff in a controlled environment. There is no screening process to determine which dogs (or owners) may visit. This means the safety of both people and dogs depends on owners being responsible and adhering to good dog park etiquette.

It is highly inadvisable to take a dog to an off-leash park until they have undergone basic training, such as the training offered at puppy preschools, followed by more advanced training. Owners need to be confident that their dog will reliably come to them when called (the 'recall' command). If owners feel unable to keep their dog under control, he or she is not ready for an off-leash park. As an alternative, dogs may benefit from a fenced off area with small, medium and large areas within an off-leash park where they can safely run off leash.

Owners also need to be confident that their dog will relate to other dogs without becoming fearful or aggressive. Dog parks such as Bert Hawke Oval or Henry Street Oval are highly arousing to all dogs due to the physical environment and the presence of other dogs. The stimulation of sudden contact with unfamiliar dogs of varying breeds, sizes and temperaments can be overwhelming for nervous dogs, especially where there is no easy escape from the situation. Dogs have four options available to them flight, fight, freeze or submit. Being on leash reduces their options and often exacerbates the problem. Being off leash increases the owners anxiety which the dog mirrors.

If the dog has not learned to socialise with other dogs, the interactions in an off-leash park, such as being approached by a group, or exposed to rough and tumble play, mounting, sniffing, chasing and barking, can be perceived as threats rather than sources of enjoyment. Unknown humans approaching can also be over stimulating. Another risk is that the dog may fail to read warning cues from other dogs to 'back off', which can lead to being bitten. A negative experience in an off-leash park has the potential to reinforce behaviour problems, especially for dogs who are not well socialised or have had traumatic experiences.

For these reasons, I support a fully fenced dog exercise area with double gates and a small, medium and large dog area. This way, dogs can have a slow and gentle initial meeting with others through double gates and the opportunity to interact with dogs of a similar size as opposed to a free for all.

Signage would be beneficial asking owners not to enter if their dog is:

- Unvaccinated
- Not wormed
- Unwell
- Not Desexed

It is important owners collect their dogs waste to prevent spread of disease. It is also important to include adequate shade and water to reduce risk of heat stroke, particularly to flat faced breeds. I would also encourage seating areas for owners, so they can relax and demonstrate calm energy as dogs mirror our energy.

Although I couldn't find any current regulation of off-leash dog parks, The Dog and Cat Management Board of South Australia has developed a resource to assist local governments to design and manage these effectively and safely. This resource has suggestions for good planning that may assist you in your choice of fenced off-leash area, including: the provision of different activity zones (to allow both high running areas and quieter areas for one-on-one play between dogs or interactions with owners), secure fencing, multiple entry and exit points to prevent dogs converging at once, adequate water and shade, signage with rules for owners to observe, and dog equipment for enrichment and practising natural skills (such as tyres, tunnels, jumps).

(1) Government of South Australia. Dog and Cat Management Board (2013).

<https://cdn.dogandcatboard.com.au/dcmb/docs/Dogs/UnleashedDogParks-B.pdf>

I have trained over 280 dogs in the Wheatbelt to date. By far, the leading trend with dogs exhibiting unwanted behaviour has been a lack of socialisation with people and/or dogs and or lack of physical and/or mental stimulation (particularly working breeds like Kelpies.)

The main reasons people report the absence of these activities, is having no confidence in recall and a fear of other dogs approaching without careful introduction first. And sadly, being time poor to walk around the streets.

Unlike many other trainers I do not offer "lessons" in the park to my clients. Teaching a dog tricks such as jumping through hoops or shaking hands is of little benefit in my opinion. This approach will not stop the dog from barking at home for instance. I am a Behaviorist first and foremost and help owners get the bottom of WHY their dog is exhibiting unwanted behaviors. Very often this has to do with the role the dog is

playing and once the owner can communicate to the dog that they can switch off and relax everything changes.

It is helpful though when a dog exhibits fear aggression to people and/or dogs or is timid to the point of stress, to take them NEAR a fenced dog area. Not into, but nearby where the dog can desensitise at a comfortable distance without unsolicited interaction. The owner can then slowly work on reducing reactivity, finish on a high and quit whilst their ahead. Eventually the dog can enter and interact. This has been the case in Merredin and York where fenced off areas have been established.

I hope that this proposal will be considered and am happy to be contacted any time.

Tanya Richardson  
Dog Trainer & Behaviorist



## Calm Canines

Helping dogs and their humans communicate





Tracy Saurin  
A1 Wheatbelt Dog Rescue  
[A1wheatbeltdogrescue@hotmail.com](mailto:A1wheatbeltdogrescue@hotmail.com)  
0408 857 854

Shire of Northam  
425 Fitzgerald St Northam, WA 6401

16<sup>th</sup> June 2022

To Whom it may concern,  
My name is Tracy Saurin and I run A1 Wheatbelt Dog Rescue.  
I am writing this letter in support of the proposed fenced dog exercise area in Northam.  
I believe that having an off-leash dog park would be hugely beneficial for dogs and their owners. To go to a designated area for a dog to run and play in a secure area would be a great advantage in Northam. To have a few sections would be the best way to go so dogs can have a secure way of having a meet & greet before going into the main are for a play with another dog.  
Thank your consideration and time in considering this proposal.

Yours sincerely,

**TSaurin**





**Wheatbelt Health Network Northam**  
ABN: 73 639 952 959  
25 Holtfreter Ave, Northam  
WA 6401  
T: 9621 4444  
F: 9621 4475  
E: [northam@wheatbelt.com.au](mailto:northam@wheatbelt.com.au)  
W: [www.wheatbelt.com.au](http://www.wheatbelt.com.au)

29th June 2022

The Shire of Northam  
PO Box 613  
NORTHAM WA 6401

Ms Terrie WEATHERBY (430968514)  
Unit2/27 Kennedy Street  
Northam  
WA Australia 6401  
[virginia.bell@nhcare.com.au](mailto:virginia.bell@nhcare.com.au)

I am wheelchair bound for mobility, and have a small dog . I would welcome a safe exercise area for my dog to exercise and we both socialise and mingle with other dogs and their owners. I am unable to safely walk my dog outside my unit as a neighbours dog barks through the fence and is intimidating to my small dog.

Yours sincerely



Terrie Weatherby



**Wheatbelt Health Network Northam**  
ABN: 73 639 952 959  
25 Holtfreter Ave, Northam  
WA 6401  
T: 9621 4444  
F: 9621 4475  
E: [northam@wheatbelt.com.au](mailto:northam@wheatbelt.com.au)  
W: [www.wheatbelt.com.au](http://www.wheatbelt.com.au)

6th July 2022

Shire of Northam.

Mrs Jennifer "Jen" STEDMAN (430367673)  
PO Box 1034  
Northam  
WA Australia 6401  
[stedmanjenn@hotmail.com](mailto:stedmanjenn@hotmail.com)

I have my name down to get an assistance dog , and being visually impaired I would appreciate a safe place to bring my dog to socialise and for my safe social interaction also.

Kind regards



Jennifer Stedman

Correct as at 3.31pm 5/7/2022

Assumptions \*\*

\*\* many Australian listed suburbs/postcodes correlate to where the petitioners computer is registered, not where they live

281 Australian signatures

\*\* no duplicates found

\*\* international signatures are signed from internationals

| Name               | City       | Postal Code | Country   | Signed On  |
|--------------------|------------|-------------|-----------|------------|
| Tanya Richardson   | Northam    | 6401        | Australia | 30/05/2022 |
| Keith Richardson   | Northam    | 6000        | Australia | 30/05/2022 |
| Kaitlyn George     | Northam    | 6401        | Australia | 30/05/2022 |
| Jamie Har          | Perth      | 6000        | Australia | 30/05/2022 |
| Justine Clune      | Dalwallinu | 6000        | Australia | 30/05/2022 |
| Kim Bassett        | Mirrabooka | 6061        | Australia | 30/05/2022 |
| Kerryn Franklin    | Northam    | 6001        | Australia | 30/05/2022 |
| Kymerlee Natkanski | Perth      | 6401        | Australia | 30/05/2022 |
| Tim Natkanski      | Northam    | 6401        | Australia | 30/05/2022 |
| Shane Sibley       | Northam    | 6401        | Australia | 30/05/2022 |
| Stephanie Talay    | Northam    | 6407        | Australia | 30/05/2022 |
| Denise Nicholson   | Northam    | 3363        | Australia | 30/05/2022 |
| Jenny Lucy         | NORTHAM    | 6401        | Australia | 30/05/2022 |
| Ann Gibbs          | Northam    | 6401        | Australia | 30/05/2022 |
| Danni Bradfield    | NORTHAM    | 6401        | Australia | 30/05/2022 |
| Clare Stephens     | Northam    | 6155        | Australia | 30/05/2022 |
| Jodie Longmire     | Northam    | 6401        | Australia | 30/05/2022 |
| lucy McManus       | northam    | 6401        | Australia | 30/05/2022 |
| Stacie aiken       | Clackline  | 6564        | Australia | 30/05/2022 |
| Esther Bliss       | Northam    | 6401        | Australia | 30/05/2022 |
| Wendy Reid         | Northam    | 6401        | Australia | 30/05/2022 |
| Jo Stephen         | Northam    | 6401        | Australia | 30/05/2022 |
| Deborah Mcquienn   | Perth      | 6208        | Australia | 30/05/2022 |

|                     |                |      |           |            |
|---------------------|----------------|------|-----------|------------|
| Kate Hayward-Waller | Northam        | 6401 | Australia | 30/05/2022 |
| Rebecca Mulholland  | Grass Valley   | 6105 | Australia | 30/05/2022 |
| Nathan Hooper       | Perth          | 6000 | Australia | 30/05/2022 |
| Tracey Gunson       | Perth          | 6060 | Australia | 30/05/2022 |
| Jean Finnigan       | Northam        | 6000 | Australia | 30/05/2022 |
| Hayley Hayes        |                | 6401 | Australia | 30/05/2022 |
| Virgil Hinsley      | Northam        | 6401 | Australia | 30/05/2022 |
| Tina McLean         | Northam        | 6317 | Australia | 30/05/2022 |
| Ms. Raelene Harris  | Northam        | 6401 | Australia | 30/05/2022 |
| Melanie Jones       | Perth          | 6000 | Australia | 30/05/2022 |
| Gwen Mills          | Perth          | 6000 | Australia | 30/05/2022 |
| Catherine Rostron   | Cunderdin      | 6407 | Australia | 30/05/2022 |
| Mackenzie Sargeant  | Perth          | 6000 | Australia | 30/05/2022 |
| Dearnna Byfield     | Northam        | 6401 | Australia | 30/05/2022 |
| Lisa Hasson         | Northam        | 6401 | Australia | 30/05/2022 |
| Pam Prater          | Northam        | 6401 | Australia | 30/05/2022 |
| Kylie Allan         | Perth          | 6000 | Australia | 30/05/2022 |
| Melissa Wilmott     | Perth          | 6000 | Australia | 30/05/2022 |
| Marcia Bignell      |                | 6401 | Australia | 30/05/2022 |
| Jeneille Sinclair   |                | 6562 | Australia | 30/05/2022 |
| Johnny MEADS        | Bakers Hill    | 6562 | Australia | 30/05/2022 |
| Paula Whittington   | Northam        | 6401 | Australia | 30/05/2022 |
| Billy Meade         | Perth          | 6000 | Australia | 30/05/2022 |
| Sandra Buttersfield | Northam        | 6401 | Australia | 30/05/2022 |
| Shelley Disney      | Northam WA     | 6401 | Australia | 30/05/2022 |
| Michelle O'Driscoll | Perth          | 6401 | Australia | 30/05/2022 |
| Karen Carter        | Northam        | 6401 | Australia | 30/05/2022 |
| Shelley McLean      | Southern Brook | 6401 | Australia | 30/05/2022 |
| Sandra Wood         | Perth          | 6151 | Australia | 30/05/2022 |
| Rebecca Potocznyj   | Northam        | 6401 | Australia | 30/05/2022 |
| Clare Arthur        | Northam        | 6401 | Australia | 30/05/2022 |
| Tina Gunter         | Melbourne      | 3011 | Australia | 30/05/2022 |
| Aaron Laird         | Perth          | 6148 | Australia | 30/05/2022 |

|                          |             |      |           |            |
|--------------------------|-------------|------|-----------|------------|
| Bernie Swindells         | Northam     | 6401 | Australia | 30/05/2022 |
| Sue Rodgers              | Northam     | 6401 | Australia | 30/05/2022 |
| Maria Spark              | Northam     | 6401 | Australia | 30/05/2022 |
| Jennifer Thompson        | Northam     | 6401 | Australia | 30/05/2022 |
| Sarah Smith              | Northam     | 6401 | Australia | 30/05/2022 |
| Clare McAlaney           |             | 3195 | Australia | 30/05/2022 |
| Emily Allan              | Northam     | 6401 | Australia | 30/05/2022 |
| Amber Balfour-Cunningham | Perth       | 6000 | Australia | 30/05/2022 |
| Pip Corteen              | Perth       | 6000 | Australia | 30/05/2022 |
| Grace Heffernan          | Perth       | 6000 | Australia | 30/05/2022 |
| Debbie Hughes            | Northam     | 6401 | Australia | 30/05/2022 |
| Daniel McDonald          | Perth       | 6000 | Australia | 30/05/2022 |
| Sophia Gobby             | Northam     | 6401 | Australia | 30/05/2022 |
| Tiffany-Kate DeMarchi    | Perth       | 6000 | Australia | 30/05/2022 |
| Janine Bell              | Northam     | 6401 | Australia | 30/05/2022 |
| Hazel King               | Perth       | 6000 | Australia | 30/05/2022 |
| Patrick Eid              | Illawong    | 2234 | Australia | 30/05/2022 |
| magdalena niedzielska    | Sydney      | 2000 | Australia | 30/05/2022 |
| Matthew Kelly            | Millendon   | 6056 | Australia | 30/05/2022 |
| Paula Cranny             | Perth       | 6000 | Australia | 30/05/2022 |
| Nadine Clark             | Perth       | 6000 | Australia | 30/05/2022 |
| Tanya EVANS              | WA          | 6753 | Australia | 30/05/2022 |
| Jess Smith               | Carlton     | 3053 | Australia | 30/05/2022 |
| Amanda Abbott            | Perth       | 6401 | Australia | 30/05/2022 |
| Krischne Swanton         | Perth       | 6000 | Australia | 31/05/2022 |
| Georgina Critchlow       | York        | 6302 | Australia | 31/05/2022 |
| Brooke Kujundzic         | Perth       | 6000 | Australia | 31/05/2022 |
| Patricia Rumjantsev      | Bakers Hill | 6562 | Australia | 31/05/2022 |
| Beth Carpenter           | Northam     | 6401 | Australia | 31/05/2022 |
| Toni Korotschuk-Rose     | Northam     | 6401 | Australia | 31/05/2022 |
| Marilyn de Beaux         | Northam     | 6401 | Australia | 31/05/2022 |
| Helen Singh              | Perth       | 6401 | Australia | 31/05/2022 |
| Stolp Abigail            | Northam     | 6401 | Australia | 31/05/2022 |

|                   |                |      |           |            |
|-------------------|----------------|------|-----------|------------|
| Emily Purcell     | Clackline      | 6564 | Australia | 31/05/2022 |
| Katy Harman       | Northam        | 6401 | Australia | 31/05/2022 |
| Tracy Knappett    | Spencers Brook | 6000 | Australia | 31/05/2022 |
| Lois Harman       | Perth          | 6000 | Australia | 31/05/2022 |
| Annabelle Marlow  | Melbourne      | 3000 | Australia | 31/05/2022 |
| Joanne Campione   | Tweed Heads    | 2485 | Australia | 31/05/2022 |
| Kath Boyle        | Northam        | 6401 | Australia | 31/05/2022 |
| James Fallows     | Leschenault    | 6233 | Australia | 31/05/2022 |
| Michael Rice      | Northam        | 6401 | Australia | 31/05/2022 |
| Jill Rice         | Northam        | 6401 | Australia | 31/05/2022 |
| Andrea Haigh      | Northam        | 6401 | Australia | 31/05/2022 |
| Thomas Hayes      | Northam        | 6401 | Australia | 31/05/2022 |
| Tracey Burges     | Wundowie       | 6560 | Australia | 31/05/2022 |
| Belinda Shaw      | Northam        | 6401 | Australia | 31/05/2022 |
| Jilly Wegner      | Northam        | 6405 | Australia | 31/05/2022 |
| Tiffany Cramer    | Perth          | 6000 | Australia | 31/05/2022 |
| Charissa Harvey   | Northam        | 6401 | Australia | 31/05/2022 |
| Maree Moore       | Perth          | 6401 | Australia | 31/05/2022 |
| Steven Brown      | Perth          | 6000 | Australia | 31/05/2022 |
| Cityrailsaints -- | Sydney         | 2190 | Australia | 1/06/2022  |
| Rose-Maree Ezeh   | Northam        | 6401 | Australia | 1/06/2022  |
| Claire Harloe     | Karrinyup      | 6018 | Australia | 1/06/2022  |
| Azfar Raza        | Sydney         | 2000 | Australia | 2/06/2022  |
| Joanne Buckley    | Gold Coast     | 4221 | Australia | 2/06/2022  |
| Lynn Travis       | Clackline      | 6564 | Australia | 2/06/2022  |
| Tjana Schmidt     | Brisbane       | 4000 | Australia | 3/06/2022  |
| Suzanne Roper     | Northam        | 6401 | Australia | 3/06/2022  |
| Anita Hodak       | Brisbane       | 4068 | Australia | 3/06/2022  |
| Potter Taylor     | Northam        | 6401 | Australia | 3/06/2022  |
| Mel Rowling       | Northam        | 6401 | Australia | 3/06/2022  |
| John Reynolds     | Sydney         | 2076 | Australia | 3/06/2022  |
| Saviz Kohistani   | Perth          | 6000 | Australia | 4/06/2022  |
| Ronnie Steele     | Northam        | 6401 | Australia | 4/06/2022  |

|                      |                |      |           |           |
|----------------------|----------------|------|-----------|-----------|
| Roma West            | Perth          | 6000 | Australia | 4/06/2022 |
| Debbie Barrett       | Perth          | 6401 | Australia | 5/06/2022 |
| Jodie Byers          | Northam        | 6401 | Australia | 5/06/2022 |
| Katina Baker         |                | 2229 | Australia | 5/06/2022 |
| Harlequin Goodes     | traralgon      | 3844 | Australia | 5/06/2022 |
| Rebecca Gordon       | Northam        | 6401 | Australia | 5/06/2022 |
| Steve Lipple         | Ringwood       | 3134 | Australia | 5/06/2022 |
| Natalie Opitz        | Port Macquarie | 2444 | Australia | 6/06/2022 |
| Pam Scamardella      | Ravenshoe      | 4888 | Australia | 6/06/2022 |
| Finn Brown           | Melbourne      | 3000 | Australia | 6/06/2022 |
| G Bradbury           | Northam        | 6053 | Australia | 6/06/2022 |
| Caroline Marriott    | Perth          | 6000 | Australia | 6/06/2022 |
| Julia Ryan           | Northam        | 6401 | Australia | 6/06/2022 |
| Alison Quin          | Northam        | 6401 | Australia | 6/06/2022 |
| Michaela O'DOHERTY   | Toodyay        | 6566 | Australia | 6/06/2022 |
| Davina Edwards       | Perth          | 6000 | Australia | 6/06/2022 |
| Genevieve Russ       | Northam        | 6401 | Australia | 6/06/2022 |
| Myra Hancock         |                |      | Australia | 6/06/2022 |
| Leisha Watt          | Northam        | 6401 | Australia | 6/06/2022 |
| Cheyenne Bland       | Beacon         | 6472 | Australia | 6/06/2022 |
| Cara Meeres          | Perth          | 6057 | Australia | 6/06/2022 |
| Kate Swenson         | Northam        | 6401 | Australia | 6/06/2022 |
| John Cenna           | Northam        | 6401 | Australia | 6/06/2022 |
| Sandy Floyd          | Northam        | 6401 | Australia | 6/06/2022 |
| Josh Hartland        | Northam        | 6401 | Australia | 6/06/2022 |
| Hayley Hughes        | Perth          | 6000 | Australia | 6/06/2022 |
| Dana Houzeife        | Sydney         | 2000 | Australia | 6/06/2022 |
| Joshua Reichert      | Northam        | 6401 | Australia | 7/06/2022 |
| Emily O'DONNELL      | Northam        | 6000 | Australia | 7/06/2022 |
| Kira ashworth        | Perth          | 6000 | Australia | 7/06/2022 |
| Michael Palumbo      | York           | 6302 | Australia | 7/06/2022 |
| Dempsey quartermaine | Northam        | 6401 | Australia | 7/06/2022 |
| Karen ODriscoll      | Perth          | 6000 | Australia | 7/06/2022 |

|                      |              |      |           |           |
|----------------------|--------------|------|-----------|-----------|
| Heather Meiklem      | Northam      | 6403 | Australia | 7/06/2022 |
| Margi M              | Northam      | 6401 | Australia | 7/06/2022 |
| Liam Mayo            | Northam      | 6401 | Australia | 7/06/2022 |
| Alanah Maddeford     | Bakers hill  | 6562 | Australia | 7/06/2022 |
| Andrea Church        | Northam      | 6401 | Australia | 7/06/2022 |
| Emma Chivell-O'Lynn  | Victoria     | 3197 | Australia | 7/06/2022 |
| Megan Glenie         | Northam      | 6401 | Australia | 7/06/2022 |
| Sheryl Thompson      | Perth        | 6000 | Australia | 7/06/2022 |
| Vesna AVRAMOSKI      | Sydney       | 2001 | Australia | 7/06/2022 |
| Jade Burgess         | Perth        | 6000 | Australia | 7/06/2022 |
| Chantal Hughes       | Perth        | 6403 | Australia | 7/06/2022 |
| Jessica Ducat        | Perth        | 6000 | Australia | 7/06/2022 |
| Chloe Bailey         | Geraldton    | 6530 | Australia | 7/06/2022 |
| Marilyn Hecker       | Northam      | 6401 | Australia | 7/06/2022 |
| Rowena Nunn          |              |      | Australia | 7/06/2022 |
| Michaela Sandrini    | Perth        | 6001 | Australia | 7/06/2022 |
| Jordan Davis         | Northam      | 6401 | Australia | 7/06/2022 |
| Nicky Wille          | Perth        | 6000 | Australia | 7/06/2022 |
| Annette Gorman       | Northam      | 6401 | Australia | 7/06/2022 |
| Carolyn Carver       |              |      | Australia | 7/06/2022 |
| Mckayla Young        | Perth        | 6000 | Australia | 7/06/2022 |
| Phoebe McGuinness    | Broome       | 6725 | Australia | 7/06/2022 |
| Rebecca Robles       | Northam      | 6401 | Australia | 7/06/2022 |
| Lorraine Kimberley   | Northam      | 6401 | Australia | 7/06/2022 |
| Kylie Howard         | Perth        | 6401 | Australia | 7/06/2022 |
| Rhys K               | Perth        | 6000 | Australia | 7/06/2022 |
| Paula Pisani         | Perth        | 6000 | Australia | 7/06/2022 |
| Luke Bidstrup        | Perth        | 6000 | Australia | 7/06/2022 |
| Josh Cording         | Perth        | 6000 | Australia | 8/06/2022 |
| Kirra ten Hove-Smith | Perth        | 6004 | Australia | 8/06/2022 |
| Adrian Hardy         | Perth        | 6000 | Australia | 8/06/2022 |
| Aya Danin            | Northam      | 6401 | Australia | 8/06/2022 |
| Elisha Mayers        | Forrestfield | 6058 | Australia | 8/06/2022 |



|                   |                   |      |           |           |
|-------------------|-------------------|------|-----------|-----------|
| Roni Sewell       | YORK              | 6302 | Australia | 8/06/2022 |
| Beryl Harmer      | Western Australia | 6490 | Australia | 8/06/2022 |
| Kai Ashton        | Northam           | 6401 | Australia | 8/06/2022 |
| Tina Roser        | Northam           | 6401 | Australia | 8/06/2022 |
| Helen Miller      | Northam           | 6401 | Australia | 8/06/2022 |
| David Burgin      | York              | 6302 | Australia | 8/06/2022 |
| Amelia Howell     | Melbourne         | 3338 | Australia | 8/06/2022 |
| Jenny Josephs     | YORK              | 6302 | Australia | 8/06/2022 |
| Tamara Miller     | Perth             | 6000 | Australia | 8/06/2022 |
| Evie O'Brien      | Bakers Hill       | 6562 | Australia | 8/06/2022 |
| Sandy Boorman     | Perth             | 6147 | Australia | 8/06/2022 |
| Wesley Sutton     | Toodyay           | 6566 | Australia | 8/06/2022 |
| Rebecca Fowles    | Perth             | 6000 | Australia | 8/06/2022 |
| Theresa Tunna     | Perth             | 6166 | Australia | 8/06/2022 |
| Reny Luisa        | Perth             | 6000 | Australia | 8/06/2022 |
| Lauren O'Neil     |                   | 6000 | Australia | 8/06/2022 |
| Carol Head        | Bakers Hill       | 6562 | Australia | 8/06/2022 |
| Boorman Sally     | Perth             | 6000 | Australia | 8/06/2022 |
| Dannielle Cara    |                   |      | Australia | 8/06/2022 |
| Annette Hazlewood | Northam           | 6014 | Australia | 8/06/2022 |
| Rebecca Hameister | Perth             | 6000 | Australia | 8/06/2022 |
| Emily Burrow      | Perth             | 6401 | Australia | 8/06/2022 |
| Sandra Parry      | West Toodyay      | 6566 | Australia | 8/06/2022 |
| Justin Saine      |                   |      | Australia | 8/06/2022 |
| Kylie Chambers    | Northam           | 6401 | Australia | 8/06/2022 |
| Lee-Ellen Edmonds |                   | 6302 | Australia | 8/06/2022 |
| Emma Louise       | Northam           | 6401 | Australia | 8/06/2022 |
| Alysia Holt       | Perth             | 6000 | Australia | 9/06/2022 |
| Louisa Langford   | Perth             | 6000 | Australia | 9/06/2022 |
| Kirra Cole        |                   | 6401 | Australia | 9/06/2022 |
| Tayla Barnett     | Northam           | 6401 | Australia | 9/06/2022 |
| Zabrina Dick      |                   | 6401 | Australia | 9/06/2022 |
| Julie Letton      |                   |      | Australia | 9/06/2022 |

|                        |             |      |           |            |
|------------------------|-------------|------|-----------|------------|
| Ryan Guilfoyle         | Perth       | 6000 | Australia | 9/06/2022  |
| Krystle Burgess        | Northam     | 6401 | Australia | 9/06/2022  |
| Jayde Cleasby          | Northam     | 6302 | Australia | 9/06/2022  |
| Emma Elliott           | Meckering   | 6405 | Australia | 9/06/2022  |
| Tracy Thomassen        | Melbourne   | 3029 | Australia | 9/06/2022  |
| Roz Taylor             |             | 6054 | Australia | 9/06/2022  |
| ve i                   | Sydney      | 2000 | Australia | 9/06/2022  |
| Aliyah Abifares        | Brisbane    | 4000 | Australia | 9/06/2022  |
| Melissa Smith          |             | 6106 | Australia | 9/06/2022  |
| Sonya Lee Lindner      | Perth       | 6000 | Australia | 10/06/2022 |
| Shagun Sharma          |             | 2131 | Australia | 10/06/2022 |
| Leo :D                 | Brisbane    | 4000 | Australia | 10/06/2022 |
| Gale Webster           | Scarborough | 6019 | Australia | 10/06/2022 |
| Tess Bonanni           | Brisbane    | 4000 | Australia | 10/06/2022 |
| Mansour Gholami        | Sydney      | 2000 | Australia | 10/06/2022 |
| Darrell Foote          | Adelaide    | 5033 | Australia | 11/06/2022 |
| Andrea Baker           | Northam     | 6401 | Australia | 11/06/2022 |
| Alana Weatherly        | Northam     | 6401 | Australia | 11/06/2022 |
| Nicole Gibson          | Northam     | 6401 | Australia | 11/06/2022 |
| Alison McNamara        |             | 4211 | Australia | 11/06/2022 |
| Sarah Allum            | Perth       | 6000 | Australia | 11/06/2022 |
| Michelle Garwood       | Perth       | 6000 | Australia | 11/06/2022 |
| Peta Wheatley          | Gympie      | 4570 | Australia | 11/06/2022 |
| Wayne Darley           | Northam     | 6401 | Australia | 11/06/2022 |
| Cherie Harvey          | Perth       | 6000 | Australia | 11/06/2022 |
| Kathrynne Grundy       | Perth       | 6372 | Australia | 11/06/2022 |
| Maddison Clark-Philbey | Northam     | 6401 | Australia | 11/06/2022 |
| Jack Pollock           | Northam     | 6401 | Australia | 12/06/2022 |
| Amelia James           | Sydney      | 2000 | Australia | 12/06/2022 |
| Saloam Frazer          | Ellenbrook  | 6069 | Australia | 13/06/2022 |
| David Bradley          | Northam     | 6401 | Australia | 13/06/2022 |
| Deb Bewley             | Townsville  | 4815 | Australia | 13/06/2022 |
| Mike Oxchlong          | Sydney      | 2000 | Australia | 14/06/2022 |

|                     |                |           |           |            |
|---------------------|----------------|-----------|-----------|------------|
| Lynne Clarke        | Dowerin        | 6461      | Australia | 14/06/2022 |
| Casey Garlett       | Northam        | 6401      | Australia | 20/06/2022 |
| Natalie Garlett     | Perth          | 6000      | Australia | 20/06/2022 |
| Melinda Thorn       | Perth          | 6056      | Australia | 21/06/2022 |
| Heath Croker        |                |           | Australia | 21/06/2022 |
| Victoria Davis      | Northam        | 6401      | Australia | 24/06/2022 |
| Emma Hazelden       | Perth          | 6000      | Australia | 24/06/2022 |
| Dee O'Driscoll      | Northam        | 6401      | Australia | 25/06/2022 |
| George Elenikovskii | Wollongong     | 2500      | Australia | 25/06/2022 |
| Simon. Fiveash      |                | 4178      | Australia | 25/06/2022 |
| Daphne Lobo         | Chatswood      | 2067      | Australia | 25/06/2022 |
| Fiona Cossart       | Toodyay        | 6566      | Australia | 29/06/2022 |
| Sherree W           | Northam        | 6401      | Australia | 29/06/2022 |
| Ratna Knights       | Northam        | 6401      | Australia | 29/06/2022 |
| Brittany Saulys     | Perth          | 6401      | Australia | 29/06/2022 |
| Terry Larkin        | Northam        | 6000      | Australia | 29/06/2022 |
| Peter Larkin        | Northam        | 6000      | Australia | 29/06/2022 |
| Jan McDonagh        | Perth          | 6000      | Australia | 30/06/2022 |
| Sharon Mann         | Deanmill       | 6255      | Australia | 30/06/2022 |
| Amanda Fleming      | Perth          | 6060      | Australia | 30/06/2022 |
| Amy Zwetsloot       | Northam        | 6401      | Australia | 1/07/2022  |
| Elisabeth Bechmann  | Polten         | 3100      | Austria   | 7/06/2022  |
| Bambi Mayr          |                |           | Austria   | 9/06/2022  |
| Cuisenaire Martine  | Heer           | 5543      | Belgium   | 7/06/2022  |
| Sylvia DRIOULE      | Liège          |           | Belgium   | 8/06/2022  |
| Marc Huysmans       | Edegem         |           | Belgium   | 8/06/2022  |
| Alain Neven         | Seraing        |           | Belgium   | 8/06/2022  |
| simone maes         |                | 9000      | Belgium   | 8/06/2022  |
| Andréa Branco       | Sao Paulo      | 4110      | Brazil    | 8/06/2022  |
| Doris Matte         | Porto Alegre   | 90000     | Brazil    | 8/06/2022  |
| Renata Cheferrino   | Rio de Janeiro | 22785-200 | Brazil    | 9/06/2022  |
| Gerard Goulette     | Montréal       | H1e3e9    | Canada    | 7/06/2022  |
| Joyce Brown         | longueuil      | j4l 1r8   | Canada    | 7/06/2022  |

|                    |                   |         |         |            |
|--------------------|-------------------|---------|---------|------------|
| Mike Andrews       | Hamilton          | L8N1M2  | Canada  | 8/06/2022  |
| sylvie auger       | Trois-Rivières    | G8Y 6S9 | Canada  | 8/06/2022  |
| Luc Beaulieu       | Montréal          | H3G     | Canada  | 8/06/2022  |
| Cindy Janzen       | Niagara Falls     | L2G     | Canada  | 11/06/2022 |
| Kristina Sedic     | Zagreb            | 10000   | Croatia | 8/06/2022  |
| Niina Anttinen     | Espoo             |         | Finland | 7/06/2022  |
| Nina Lättilä       | Rajamäki          |         | Finland | 8/06/2022  |
| Ulbrich Christiane | Moyeuivre-grande  | 57250   | France  | 7/06/2022  |
| Caroline Sévilla   | Paris             | 75001   | France  | 7/06/2022  |
| Veronique Dick     |                   | 57700   | France  | 7/06/2022  |
| cathala corine     | Pierrelatte       | 26700   | France  | 7/06/2022  |
| jade ALF           | Blois             | 41000   | France  | 7/06/2022  |
| Frédéric Jaubert   | Pont de Chéruy    | 38230   | France  | 7/06/2022  |
| Raphaël PONCE      | TOULOUSE          | 31140   | France  | 7/06/2022  |
| Djamila grouci     | Paris             | 75011   | France  | 7/06/2022  |
| Dominique LANG     | Vaison-la-Romaine | 84110   | France  | 7/06/2022  |
| Chantal Thomas     | Frejus            | 83600   | France  | 8/06/2022  |
| alan henry         | Tours             | 37100   | France  | 8/06/2022  |
| Nelly PRESTAT      | Mouroux           | 77120   | France  | 8/06/2022  |
| vie.espoir         | La Suze           | 72210   | France  | 8/06/2022  |
| Francine Sandras   | Annoeullin        | 59112   | France  | 8/06/2022  |
| Shayna Tyler       | Vallentigny       | 10500   | France  | 8/06/2022  |
| Sabine Möhler      | Esselbach         | 97839   | Germany | 7/06/2022  |
| Petra Achtzehnter  | Kaiserslautern    | 67663   | Germany | 7/06/2022  |
| Marion Piepenbrink | Dusseldorf        | 40472   | Germany | 7/06/2022  |
| Anne Montarou      | Ahrensburg        | 22926   | Germany | 7/06/2022  |
| A. Otto            | Auerbach          | 8209    | Germany | 7/06/2022  |
| Petra Hegenscheidt | Essen             |         | Germany | 7/06/2022  |
| christa lohrig     | Petersberg        | 41352   | Germany | 7/06/2022  |
| Uwe Vietzke        |                   |         | Germany | 7/06/2022  |
| Claudia Neuhalfen  | Bonn              | 53117   | Germany | 7/06/2022  |
| Rosi Zang          | Aschaffenburg     | 63743   | Germany | 7/06/2022  |
| marion jurchen     | Berlin            | 13409   | Germany | 7/06/2022  |

|                         |                           |         |               |            |
|-------------------------|---------------------------|---------|---------------|------------|
| holger meyer            | Weyhe                     | 28844   | Germany       | 7/06/2022  |
| Ana Gruber              | Wolfratshausen            | 82515   | Germany       | 7/06/2022  |
| R S                     | Koln                      | 51069   | Germany       | 7/06/2022  |
| Ellen Gurtner           | Mönchengladbach           | 41189   | Germany       | 7/06/2022  |
| Nadine Baldi            | Karlsdorf-Neuthard        | 76709   | Germany       | 8/06/2022  |
| Janina Grage            |                           | 44649   | Germany       | 8/06/2022  |
| Theresia Maria          | Deutschland               | 66957   | Germany       | 8/06/2022  |
| Jasmin Porschen         | München                   |         | Germany       | 8/06/2022  |
| Karin Zimmermann        | Hersbruck                 | 91217   | Germany       | 13/06/2022 |
| Brian McCabe            |                           |         | Ireland       | 6/06/2022  |
| Graham Duncan           | Dublin                    | D02     | Ireland       | 8/06/2022  |
| Consuelo Serena Velasco | Strambino Fr Cerone       | 10019   | Italy         | 8/06/2022  |
| Tiziana Dordoni         | Corsico milano            | 20094   | Italy         | 9/06/2022  |
| Christna Frutuoso       | Esch                      | 4069    | Luxembourg    | 7/06/2022  |
| hortencia mendoza       |                           | 44260   | Mexico        | 7/06/2022  |
| Maria Van Geel          | Hoogerheide               | 4631 TB | Netherlands   | 7/06/2022  |
| Anneke Andries          | Raamsdonksveer            | 4941JT  | Netherlands   | 7/06/2022  |
| Mirjam Talma            | Buitenpost                | 9285VZ  | Netherlands   | 7/06/2022  |
| Astrid V.d. Geest       | Stadskanaal               | 9502    | Netherlands   | 7/06/2022  |
| Koeno van der Schuur    | Apeldoorn                 | 7203    | Netherlands   | 8/06/2022  |
| marlie scholten         | Daarlerveen               | 7687    | Netherlands   | 8/06/2022  |
| Andre Ferro             | Helmond                   | 5707RN  | Netherlands   | 9/06/2022  |
| Chantal Martin          | Koné                      | 98807   | New Caledonia | 8/06/2022  |
| L Saunders              | Masterton                 |         | New Zealand   | 7/06/2022  |
| THERESE ANN DURANO      | Manila                    |         | Philippines   | 9/06/2022  |
| Robert Nowak            |                           |         | Poland        | 7/06/2022  |
| Oleg Kobets             | Kemerovo                  | 650001  | Russia        | 7/06/2022  |
| rolf wiesler            | Johannesburg              | 2041    | South Africa  | 12/06/2022 |
| Susana Muñoz            | Madrid                    | 28019   | Spain         | 30/05/2022 |
| Rosa Cabrerizo          | L'Hospitalet de Llobregat | 8906    | Spain         | 8/06/2022  |
| catherine cheneval      | LYON                      | 73000   | Spain         | 8/06/2022  |
| Christine Thörnwall     | Norrköping                | 602 22  | Sweden        | 8/06/2022  |
| Jacqueline Lavanchy     | Martigny                  | 1920    | Switzerland   | 7/06/2022  |

|                    |                  |            |             |            |
|--------------------|------------------|------------|-------------|------------|
| Eva Maria Genovese | MuttENZ          |            | Switzerland | 12/06/2022 |
| Sue Cone           | Hull             | HU13 9DS   | UK          | 7/06/2022  |
| Joyce Alexander    | Edinburgh        | EH11       | UK          | 7/06/2022  |
| Julie Port         | Slough           | SL1        | UK          | 7/06/2022  |
| Andrew Vallender   | Ventnor          | PO38 1BH   | UK          | 8/06/2022  |
| Bruce Forster      | Gateshead        | NE9        | UK          | 8/06/2022  |
| Alexandra Scott    | Newcastle-u-Lyme | ST5 8BE    | UK          | 9/06/2022  |
| dave cotterell     | Birmingham       | b280uw     | UK          | 15/06/2022 |
| yolanda schultes   | Wittenbach       | 9300       | US          | 7/06/2022  |
| Robbie Hacha       | New York         | 10009      | US          | 7/06/2022  |
| Kate Kenner        | Guilford         | 5301       | US          | 7/06/2022  |
| sara sang          | los angeles      | 91601      | US          | 7/06/2022  |
| sarika arora       | Alpharetta       | 30022      | US          | 7/06/2022  |
| jocelyne lapointe  | Terrebonne       | j6w0b5     | US          | 7/06/2022  |
| Maryann Staron     | Hometown         | 60456-1035 | US          | 7/06/2022  |
| Christeen Anderson | Crestview        | 32539      | US          | 7/06/2022  |
| Carmen Guillemette | Palatine         | 60074      | US          | 8/06/2022  |
| Tabitha Totten     | Cliffside Park   | 07010-1721 | US          | 8/06/2022  |
| Pam Miller         | Tolar            | 76046      | US          | 8/06/2022  |
| SHIRLEY AUSTIN     | London           | E6 2EX     | US          | 9/06/2022  |
| Janis Millu        | Franklin         | 16323      | US          | 9/06/2022  |
| Greg Ratkovsky     | Oakland          | 94619      | US          | 9/06/2022  |
| Lisa Salazar       | Shasta Lake      | 96089      | US          | 10/06/2022 |
| Nancy Petersen     | Claremont        | 91711      | US          | 15/06/2022 |



**16. URGENT BUSINESS APPROVED BY DECISION**

Nil.

**17. DECLARATION OF CLOSURE**