



Shire of Northam  
*Heritage, Commerce and Lifestyle*

# **Shire of Northam**

## **Minutes**

### **Ordinary Council Meeting**

**17 August 2022**



## DISCLAIMER

In certain circumstances members of the public are not entitled to inspect material, which in the opinion of the Chief Executive Officer is confidential, and relates to a meeting or a part of a meeting that is likely to be closed to members of the public.

No responsibility whatsoever is implied or accepted by the Shire of Northam for any act, omission, statement or intimation occurring during Council or Committee meetings.

The Shire of Northam disclaims any liability for any loss whatsoever and howsoever caused arising out of reliance by any person or legal entity on any such act, omission or statement of intimation occurring during Council or Committee meetings.

Any person or legal entity who acts or fails to act in reliance upon any statement, act or omission made in a Council or Committee meeting does so at that person's or legal entity's own risk.

In particular and without derogating in any way from the broad disclaimer above, in any discussion regarding any planning application or application for a licence, any statement or intimation of approval made by any member or Officer of the Shire of Northam during the course of any meeting is not intended to be and is not taken as notice of approval from the Shire of Northam.

The Shire of Northam advises that anyone who has any application lodged with the Shire of Northam must obtain and should only rely on WRITTEN CONFIRMATION of the outcome of the application and any conditions attaching to the decision made by the Shire of Northam in respect of the application.

The Shire of Northam advises that any plans or documents contained within this agenda may be subject to copyright law provisions (*Copyright Act 1968*, as amended) and that the express permission of the copyright owner(s) should be sought prior to their reproduction. It should be noted that copyright owners are entitled to take legal action against any persons who infringe their copyright. A reproduction of material that is protected by copyright may represent a copyright infringement.

## Contents

1.	DECLARATION OF OPENING.....	5
2.	ACKNOWLEDGEMENT TO COUNTRY.....	5
3.	ATTENDANCE.....	5
3.1	APOLOGIES.....	5
3.2	APPROVED LEAVE OF ABSENCE.....	5
3.3	ABSENT.....	5
4.	DISCLOSURE OF INTERESTS.....	6
5.	ANNOUNCEMENT BY THE PRESIDING MEMBER (WITHOUT DISCUSSION) ...	8
6.	PUBLIC QUESTION TIME.....	10
6.1	PUBLIC QUESTIONS.....	10
7.	RESPONSE TO PREVIOUS PUBLIC QUESTIONS TAKEN ON NOTICE.....	11
8.	RECEIVING OF PETITIONS, PRESENTATIONS AND DEPUTATIONS.....	11
8.1	PETITIONS.....	11
8.2	PRESENTATIONS.....	11
8.3	DEPUTATIONS.....	11
9.	APPLICATION FOR LEAVE OF ABSENCE.....	11
10.	CONFIRMATION OF MINUTES.....	13
10.1	ORDINARY COUNCIL MEETING HELD 20 JULY 2022.....	13
10.2	SPECIAL COUNCIL MEETING HELD 27 JULY 2022.....	13
10.3	NOTES FROM COUNCIL FORUM MEETING HELD 10 AUGUST 2022... ..	13
11.	ITEMS BROUGHT FORWARD FOR THE CONVENIENCE OF THOSE IN THE PUBLIC GALLERY.....	31
13.3.1	Proposed Amendment – Co-Operative Bulk Handling, Leeming Road, Grass Valley.....	31
12.	REPORTS OF COMMITTEE MEETINGS.....	95
12.1	NYOONGAR CULTURAL ADVISORY GROUP COMMITTEE MEETING HELD ON 14 MAY 2022.....	95
13.	OFFICER REPORTS.....	127
13.1	CEO'S Office.....	127
13.1.1	Lease Agreement for Northam Pistol Club, Portion of Reserve 3303, 98 Clarke Street Northam.....	127
13.2	ENGINEERING SERVICES.....	132

13.2.2 RFQ 10 of 2022 Spencers Brook Road Spray Seal & Asphalt Works .....	132
13.3 DEVELOPMENT SERVICES .....	136
13.3.2 Proposed Review of the Heritage List .....	137
13.4 CORPORATE SERVICES.....	161
13.4.1 Accounts & Statements of Accounts 1 July 2022 to 31 July 2022.....	161
13.5 COMMUNITY SERVICES .....	234
13.5.1 Nyoongar Cultural Advisory Group .....	234
14. MATTERS BEHIND CLOSED DOORS .....	245
14.1 LEASE OF A PORTION OF RESERVE 44700 .....	245
14.2 UNAUTHORISED STRUCTURE – A72.....	248
15. MOTIONS OF WHICH PREVIOUS NOTICE HAS BEEN GIVEN.....	249
15.1 FENCED DOG PARK .....	249
16. URGENT BUSINESS APPROVED BY DECISION.....	269
17. DECLARATION OF CLOSURE.....	269



## 1. DECLARATION OF OPENING

The Shire President, Cr C R Antonio declared the meeting open at 5:30pm.

## 2. ACKNOWLEDGEMENT TO COUNTRY

The Shire of Northam would like to acknowledge the Traditional Owners of the land on which we meet, the Ballardong and Whadjuk people of the Nyoongar nation and pay our respects to Elders, past present and emerging.

## 3. ATTENDANCE

### Council:

Shire President  
Deputy Shire President  
Councillors

C R Antonio  
M P Ryan  
D Galloway  
R W Tinetti  
A J Mencshelyi  
M I Girak  
J E G Williams  
D A Hughes  
H Appleton  
P Curtis

### Staff:

Chief Executive Officer  
Executive Manager Engineering Services  
Executive Manager Development Services  
Executive Manager Community Services  
Executive Manager Corporate Services  
Acting Governance Officer  
Acting Governance Coordinator

J B Whiteaker  
S Patterson  
C B Hunt  
J Metcalf  
C Young  
T P Van Beek  
A C McCall

### Gallery:

Public

Sally Hart  
Grant Park  
Jeffrey Pollard

Northam & Districts Historical Society

### 3.1 APOLOGIES

Nil.

### 3.2 APPROVED LEAVE OF ABSENCE

Nil.

### 3.3 ABSENT

Nil.

#### 4. DISCLOSURE OF INTERESTS

Members should fill in Disclosure of Interest forms for items in which they have a financial, proximity or impartiality interest and forward these to the Presiding Member before the meeting commences.

As defined in section 5.60A of the Local Government Act 1995, a **financial interest** occurs where a Councillor / Committee Member, or a person with whom the Councillor / Committee Member is closely associated, has a direct or indirect financial interest in the matter. That is, the person stands to make a financial gain or loss from the decision, either now or at some time in the future.

As defined in section 5.61 of the Local Government Act 1995, an **indirect financial interest** includes a reference to a financial relationship between that person and another person who requires a Local Government decision in relation to the matter.

As defined in section 5.60B of the Local Government Act 1995, a person has a **proximity interest** in a matter if the matter concerns a proposed change to a planning scheme affecting land that adjoins the person's land; or a proposed change to the zoning or use of land that adjoins the person's land; or a proposed development (as defined in section 5.63(5)) of land that adjoins the person's land.

As defined in 34C of the Local Government (Administration) Regulations 1996, an **impartiality interest** means an interest that could, or could reasonably be perceived to, adversely affect the impartiality of the person having the interest and includes an interest arising from kinship, friendship or membership of an association.

Item Name	Item No.	Name	Type of Interest	Nature of Interest
Proposed Amendment – Co-Operative Bulk Handling, Leeming Road, Grass Valley	13.3.1	Cr C R Antonio	Financial	Cr Antonio's farming operation holds a \$2 share in CBH.
Proposed Amendment – Co-Operative Bulk Handling, Leeming Road, Grass Valley	13.3.1	Cr R W Tinetti	Impartiality	Some of the farmers affected by use of Leeming Rd are known to Cr Tinetti.
Proposed Review of Heritage List	13.3.2	Cr M I Girak	Proximity	Cr Girak's residential property is on the proposed Heritage List.
Proposed Review of Heritage List	13.3.2	Cr A J Mencshelyi	Impartiality	Some owners of properties on the Heritage List are known to Cr

				Mencshelyi. Including Cr Girak, who is seeking a decision in reference to Lot 5.
Proposed Review of Heritage List	13.3.2	Cr R W Tinetti	Impartiality	Some owners of properties on the Heritage List are known to Cr Tinetti.
Proposed Review of Heritage List	13.3.2	Cr M P Ryan	Impartiality	One of the property owners on the proposed Heritage List is known to Cr Ryan.
Proposed Review of Heritage List	13.3.2	Cr D A Hughes	Impartiality	Cr Girak and the owner of the Northam Tavern are known to Cr Hughes.
Proposed Review of Heritage List	13.3.2	Cr J E G Williams	Impartiality	Some owners of properties on the Heritage List are known to Cr Williams. One of the homes proposed to be included is a fellow councillor. She is requesting her home not be included.
Proposed Review of Heritage List	13.3.2	Cr C R Antonio	Impartiality	Some owners of properties on the Heritage List are known to Cr Antonio. Including Cr Girak, a fellow councillor who is requesting changes to officer recommendation.
Proposed Review of Heritage List	13.3.2	Cr P T Curtis	Impartiality	Cr Girak is known to Cr Curtis
Proposed Review of Heritage List	13.3.2	Cr H J Appleton	Impartiality	Property owners on the list are known to Cr Appleton
Proposed Review of Heritage List	13.3.2	Cr D J Galloway	Impartiality	Cr Girak is known to r Galloway as another Councillor.
Unauthorised Structure – A72	14.2	Cr J E G Williams	Proximity	A property Cr Williams co-owns is located across a thoroughfare from the subject property.

## 5. ANNOUNCEMENT BY THE PRESIDING MEMBER (WITHOUT DISCUSSION)

<b>Visitations and Consultations</b>	
21/07/2022	CBH Regional Member Forum – Buckland Estate
22/07/2022	Eclipse Brewery – Wheatbelt Launch - Northam
26/07/2022	6PR Radio Interview on loss of bid for the 2022 Air Race
26/07/2022	Aboriginal Cultural Heritage Workshop - Northam
26/07/2022	Channel 9 Interview on loss of bid for the 2022 Air Race
27/07/2022	Triple M News Radio Interview on Ballooning Championship events in 2023
27/07/2022	ABC Radio Interview on Ballooning Championship events in 2023
28/07/2022	Wheatbelt Local Government COVID-19 Information video conference
29/07/2022	ABC Midwest & Wheatbelt Radio Interview on Land Rates
01/08/2022	Triple M Fortnightly Radio Interview
04/08/2022	Northam Liquor Accord Meeting
04/08/2022	Pop Up Shop Official Opening - Northam
05/08/2022	Culture and Behaviour Workshop - Online
06/08/2022	Lions Community Markets - Northam
10/08/2022	Commonwealth & State Treasury Delegation Dinner - Northam
12/08/2022	Triple M Fortnightly Radio Interview including commentary on Avon Descent
12/08/2022	ABC Midwest & Wheatbelt Morning Show broadcast from Northam
12/08/2022	Bilya Festival - Northam
13/08/2022	Avon Descent – Official Start
13/08/2022	Avon Descent Festival - Toodyay
14/08/2022	Avon Descent – End of race presentations
17/08/2022	Tour of Aurizon Rail Yard – Avon Yards - Northam
<b>Upcoming Events</b>	
18/08/2022	Regional Capitals Alliance Meeting & Strategic Planning - Perth
19/08/2022	Regional Capitals Alliance Meeting & Strategic Planning - Perth
20/08/2022	Northam Lions Club Changeover Night
23/08/2022	Dowerin Field Days Launch - Perth
24/08/2022	Dowerin Field Days – extends for two days
26/08/2022	Avon-Midland Zone Meeting – Shire of Victoria Plains
29/08/2022	Triple M Fortnightly Radio Interview
01/09/2022	Local Emergency Management Workshop & Exercise - Northam



03/09/2022	Lions Community Markets - Northam
04/09/2022	Father's Day
08/09/2022	Shire of Northam Strategic Plan Launch and Sundowner
12/09/2022	Triple M Fortnightly Radio Interview
16/09/2022	Citizenship Ceremony - Northam

### Operational Matters:

The Shire has recently published a Youth Survey –the details are as follows:

This survey takes a look at the needs and aspirations of young people living in the Shire of Northam. The survey results will help us to provide better experiences in Northam for young people.

If you're aged between 7 and 18 and live in the Northam Shire, we want to hear from you!

The survey closes 31 August 2022, and can be completed by following this link - <https://app.smartsheet.com/b/form/ab9cc99fe6b24182b32f54a108689e32>

The new waster transfer facility opened its doors on the 1<sup>st</sup> of August. Following public consultation, the name "Northam Re-Store" was chosen. This was, in part, established due to the public wishing to reduce our carbon footprint.

### Events Calendar

August is the month when one of our cornerstone events occurs. Starting with the annual Bilya Festival on Friday night and extending to the start of the annual Avon Descent Race on Saturday morning. These events attract many visitors to the Shire, including media outlets, which further increases positive coverage.

The recent announcement of both the National Ballooning Championships in May 2023 and Women's World Ballooning Championships in September 2023 further cement our position as one of, if not the, preeminent Hot Air Ballooning Capital of Australia.

### Strategic Matters:

With the Shire of Northam recently finalising the review of the Strategic Community and Corporate Business Plans, there will be an official launch at the start of September. This allows all of residents, ratepayers and the general public to see what, based on consultation, has already occurred, is being undertaken, or has been completed since the review started.

## 6. PUBLIC QUESTION TIME

### 6.1 PUBLIC QUESTIONS

<b>Name</b>	Jeffrey Pollard.
<b>Summary Question 1:</b>	<b>of</b> With respect to item 13.3.2, how was the review of the Heritage List advertised (i.e. was it advertised to the community or only the property owners)?
<b>Summary Response Question 1:</b>	<b>of to</b> The Executive Manager Development Services advised that this was advertised to the property owners only. Council will be undertaking a review of the Heritage Strategy (previously known as the Heritage Inventory) which will be advertised to the community to provide comments.
<b>Summary Question 2:</b>	<b>of</b> With respect to item 13.3.2, is the Heritage List a living document that can be added to/amended?
<b>Summary Response Question 2:</b>	<b>of to</b> The Executive Manager Development Services advised the public can make suggestions to the Shire at anytime to be taken into consideration.

---

<b>Name</b>	Grant Park.
<b>Summary Question 1:</b>	<b>of</b> With respect to item 13.3.1, how was Leeming Rd West allowed to be excluded from the Traffic Impact Assessment? Leeming Rd West has had false information used to exclude it from the assessment, this includes stating there is a closed gate restricting access to the site from the west which is false as there is no gate at all. The CBH submission states that because of this closed gate, road condition and low rating that it assumes 100% of movements will be from Great Eastern Highway side of Leeming Rd. This is false as seen during the last harvest.
<b>Summary Response Question 1:</b>	<b>of to</b> The Executive Manager Development Services advised that there is a condition listed that states that the trucks can not use that part of the Leeming Road West. The applicant is also required to provide a Construction Management Plan which will allow Council to better understand and manage the

number, frequency and impact of the truck movements during the construction phase.

**Summary Question 2:** of With respect to item 13.3.1, the trucks had used this part of Leeming Rd West during the last harvest, was there a condition not allowing this to occur?

**Summary Response Question 2:** of The Executive Manager Development Services advised that the previous approval included a condition to not allow this portion of road to be used. If Leeming Rd West was used, the applicant may have been non-compliant with the previous approval. Now that Officers are aware of this issue, Council's Compliance Officer can monitor the approval.

## 7. RESPONSE TO PREVIOUS PUBLIC QUESTIONS TAKEN ON NOTICE

Nil.

## 8. RECEIVING OF PETITIONS, PRESENTATIONS AND DEPUTATIONS

### 8.1 PETITIONS

Nil.

### 8.2 PRESENTATIONS

Nil.

### 8.3 DEPUTATIONS

Nil.

## 9. APPLICATION FOR LEAVE OF ABSENCE

### RECOMMENDATION / COUNCIL DECISION

**Minute No: C.4527**

**Moved: Cr Ryan**

**Seconded: Cr Girak**

**That the Council grant Cr H J Appleton Leave of Absence from 05 September 2022 to 11 September 2022 (inclusive).**

**CARRIED 10/0**

**RECOMMENDATION / COUNCIL DECISION**

**Minute No: C.4528**

**Moved: Cr Ryan**

**Seconded: Cr Mencshelyi**

**That the Council grant Cr D A Hughes Leave of Absence from 03 October 2022 to 10 October 2022 (inclusive).**

**CARRIED 10/0**

## 10. CONFIRMATION OF MINUTES

### 10.1 ORDINARY COUNCIL MEETING HELD 20 JULY 2022

#### RECOMMENDATION / COUNCIL DECISION

**Minute No: C.4529**

**Moved: Cr Hughes**

**Seconded: Cr Girak**

**That the minutes of the Ordinary Council meeting held on Wednesday, 20 July 2022 be confirmed as a true and correct record of that meeting.**

**CARRIED 10/0**

### 10.2 SPECIAL COUNCIL MEETING HELD 27 JULY 2022

#### RECOMMENDATION / COUNCIL DECISION

**Minute No: C.4530**

**Moved: Cr Mencshelyi**

**Seconded: Cr Appleton**

**That the minutes of the Special Council meeting held on Wednesday, 27 July 2022 be confirmed as a true and correct record of that meeting.**

**CARRIED 10/0**

### 10.3 NOTES FROM COUNCIL FORUM MEETING HELD 10 AUGUST 2022

#### RECOMMENDATION / COUNCIL DECISION

**Minute No: C.4531**

**Moved: Cr Ryan**

**Seconded: Cr Girak**

**That Council receive the notes from the Council Forum meeting held Wednesday, 10 August 2022.**

**CARRIED 10/0**



## **Shire of Northam**

### **Notes**

### **Council Forum Meeting**

**10 August 2022**

### DISCLAIMER

This agenda has yet to be dealt with by the Council. The Recommendations shown at the foot of each item have yet to be considered by the Council and are not to be interpreted as being the position of the Council. The minutes of the meeting held to discuss this agenda should be read to ascertain the decision of the Council.

In certain circumstances members of the public are not entitled to inspect material, which in the opinion of the Chief Executive Officer is confidential, and relates to a meeting or a part of a meeting that is likely to be closed to members of the public.

No responsibility whatsoever is implied or accepted by the Shire of Northam for any act, omission, statement or intimation occurring during Council or Committee meetings.

The Shire of Northam disclaims any liability for any loss whatsoever and howsoever caused arising out of reliance by any person or legal entity on any such act, omission or statement of intimation occurring during Council or Committee meetings.

Any person or legal entity who acts or fails to act in reliance upon any statement, act or omission made in a Council or Committee meeting does so at that person's or legal entity's own risk.

In particular and without derogating in any way from the broad disclaimer above, in any discussion regarding any planning application or application for a licence, any statement or intimation of approval made by any member or Officer of the Shire of Northam during the course of any meeting is not intended to be and is not taken as notice of approval from the Shire of Northam.

The Shire of Northam advises that anyone who has any application lodged with the Shire of Northam must obtain and should only rely on WRITTEN CONFIRMATION of the outcome of the application and any conditions attaching to the decision made by the Shire of Northam in respect of the application.

The Shire of Northam advises that any plans or documents contained within this agenda may be subject to copyright law provisions (*Copyright Act 1968*, as amended) and that the express permission of the copyright owner(s) should be sought prior to their reproduction. It should be noted that copyright owners are entitled to take legal action against any persons who infringe their copyright. A reproduction of material that is protected by copyright may represent a copyright infringement.

### Preface

When the Chief Executive Officer approves these Notes for distribution they are in essence "informal notes."

At the next Ordinary Meeting of Council the Notes will be received, subject to any amendments made by the Council. The "Received" Notes are then signed off by the Presiding Person.

Please refer to the Ordinary Council meeting agenda and minutes for further information and details in relation to the matters and items discussed at the Forum meeting.

### Unconfirmed Notes

These notes were approved for distribution on 15 July 2022.



**JASON WHITEAKER**  
**CHIEF EXECUTIVE OFFICER**

### Received Notes

These notes were received at an Ordinary Meeting of Council held on 20 July 2022.

Signed:  .....

*Note: The Presiding Member at the meeting at which the minutes were confirmed is the person who signs above.*



## Contents

1.	DECLARATION OF OPENING.....	6
2.	ACKNOWLEDGEMENT TO COUNTRY.....	6
3.	ATTENDANCE.....	6
3.1	APOLOGIES.....	6
3.2	APPROVED LEAVE OF ABSENCE.....	6
3.3	ABSENT.....	6
4.	DISCLOSURE OF INTERESTS.....	7
5.	ANNOUNCEMENT BY THE PRESIDING MEMBER (WITHOUT DISCUSSION) ...	9
6.	PUBLIC QUESTION TIME.....	9
6.1	PUBLIC QUESTIONS.....	9
7.	RESPONSE TO PREVIOUS PUBLIC QUESTIONS TAKEN ON NOTICE.....	9
8.	RECEIVING OF PETITIONS, PRESENTATIONS AND DEPUTATIONS.....	9
8.1	PETITIONS.....	9
8.2	PRESENTATIONS.....	9
8.3	DEPUTATIONS.....	9
9.	APPLICATION FOR LEAVE OF ABSENCE.....	9
10.	CONFIRMATION OF MINUTES.....	9
10.1	ORDINARY COUNCIL MEETING HELD 20 JULY 2022.....	9
10.2	SPECIAL COUNCIL MEETING HELD 27 JULY 2022.....	9
10.3	NOTES FROM COUNCIL FORUM MEETING HELD 10 AUGUST 2022.....	9
11.	ITEMS BROUGHT FORWARD FOR THE CONVENIENCE OF THOSE IN THE PUBLIC GALLERY.....	10
12.	REPORTS OF COMMITTEE MEETINGS.....	10
12.1	NYOONGAR CULTURAL ADVISORY GROUP COMMITTEE MEETING HELD ON 14 MAY 2022.....	10
13.	OFFICER REPORTS.....	10
13.1	CEO'S Office.....	10
13.1.1	Lease Agreement for Northam Pistol Club, Portion of Reserve 3303, 98 Clarke Street Northam.....	10
13.2	ENGINEERING SERVICES.....	11
13.2.2	RFQ 10 of 2022 Spencers Brook Road Spray Seal & Asphalt Works.....	11
13.3	DEVELOPMENT SERVICES.....	11

Council Forum Meeting Notes  
10 August 2022



13.3.1	Proposed Amendment – Co-Operative Bulk Handling, Leeming Road, Grass Valley .....	11
13.3.2	Proposed Review of the Heritage List .....	12
13.4	CORPORATE SERVICES .....	13
13.4.1	Accounts & Statements of Accounts 1 July 2022 to 31 July 2022.....	13
13.5	COMMUNITY SERVICES .....	15
13.5.1	Nyoongar Cultural Advisory Group .....	15
14.	MATTERS BEHIND CLOSED DOORS .....	15
14.1	LEASE OF A PORTION OF RESERVE 44700 .....	15
14.2	UNAUTHORISED STRUCTURE – A72.....	16
15.	MOTIONS OF WHICH PREVIOUS NOTICE HAS BEEN GIVEN.....	17
15.1	FENCED DOG PARK .....	17
16.	URGENT BUSINESS APPROVED BY DECISION .....	17
17.	DECLARATION OF CLOSURE .....	17

Council Forum Meeting Notes  
10 August 2022



**1. DECLARATION OF OPENING**

The Shire President, Cr C R Antonio declared the meeting open at 5.30pm.

**2. ACKNOWLEDGEMENT TO COUNTRY**

The Shire of Northam would like to acknowledge the Traditional Owners of the land on which we meet, the Ballardong and Whadjuk people of the Nyoongar nation and pay our respects to Elders, past present and emerging.

**3. ATTENDANCE**

**Council:**

Shire President  
Deputy Shire President  
Councillors

C R Antonio  
M P Ryan  
D Galloway  
R W Tinetti  
A J Mencshelyi  
M I Girak  
J E G Williams  
D A Hughes  
H Appleton  
P Curtis

**Staff:**

Chief Executive Officer  
Executive Manager Engineering Services  
Executive Manager Development Services  
Executive Manager Community Services  
Executive Manager Corporate Services  
Acting Governance Officer

J B Whiteaker  
S Patterson  
C B Hunt  
J Metcalf  
C Young  
T P Van Beek

**3.1 APOLOGIES**

Acting Governance Coordinator

A C McCall

**3.2 APPROVED LEAVE OF ABSENCE**

Nil.

**3.3 ABSENT**

Nil.

Council Forum Meeting Notes  
10 August 2022



#### 4. DISCLOSURE OF INTERESTS

Members should fill in Disclosure of Interest forms for items in which they have a financial, proximity or impartiality interest and forward these to the Presiding Member before the meeting commences.

As defined in section 5.60A of the Local Government Act 1995, a **financial interest** occurs where a Councillor / Committee Member, or a person with whom the Councillor / Committee Member is closely associated, has a direct or indirect financial interest in the matter. That is, the person stands to make a financial gain or loss from the decision, either now or at some time in the future.

As defined in section 5.61 of the Local Government Act 1995, an **indirect financial interest** includes a reference to a financial relationship between that person and another person who requires a Local Government decision in relation to the matter.

As defined in section 5.60B of the Local Government Act 1995, a person has a **proximity interest** in a matter if the matter concerns a proposed change to a planning scheme affecting land that adjoins the person's land; or a proposed change to the zoning or use of land that adjoins the person's land; or a proposed development (as defined in section 5.63(5)) of land that adjoins the person's land.

As defined in 34C of the Local Government (Administration) Regulations 1996, an **impartiality interest** means an interest that could, or could reasonably be perceived to, adversely affect the impartiality of the person having the interest and includes an interest arising from kinship, friendship or membership of an association.

Item Name	Item No.	Name	Type of Interest	Nature of Interest
Proposed Amendment – Co-Operative Bulk Handling, Leeming Road, Grass Valley	13.3.1	Cr C R Antonio	Financial	Cr Antonio's farming operation holds a \$2 share in CBH.
Proposed Review of Heritage List	13.3.2	Cr M I Girak	Proximity	Cr Girak's residential property is on the proposed Heritage List.
Proposed Review of Heritage List	13.3.2	Cr A J Mencshelyi	Impartiality	Some owners of properties on the Heritage List are known to Cr Mencshelyi
Proposed Review of Heritage List	13.3.2	Cr R W Tinetti	Impartiality	Some owners of properties on the Heritage List are known to Cr Tinetti

Council Forum Meeting Notes  
**10 August 2022**

Proposed Review of Heritage List	13.3.2	Cr M P Ryan	Impartiality	One of the property owners on the proposed Heritage List is known to Cr Ryan.
Proposed Review of Heritage List	13.3.2	Cr D A Hughes	Impartiality	One of the property owners on the proposed Heritage List is known to Cr Hughes.
Proposed Review of Heritage List	13.3.2	Cr J E G Williams	Impartiality	Some owners of properties on the Heritage List are known to Cr Williams.
Proposed Review of Heritage List	13.3.2	Cr C R Antonio	Impartiality	Some owners of properties on the Heritage List are known to Cr Antonio.
Unauthorised Structure – A72	14.2	Cr J E G Williams	Proximity	A property Cr Williams co-owns is located across a thoroughfare from the subject property.

Council Forum Meeting Notes  
10 August 2022



**5. ANNOUNCEMENT BY THE PRESIDING MEMBER (WITHOUT DISCUSSION)**

No queries were raised in relation to these items.

**6. PUBLIC QUESTION TIME**

**6.1 PUBLIC QUESTIONS**

Nil

**7. RESPONSE TO PREVIOUS PUBLIC QUESTIONS TAKEN ON NOTICE**

Nil.

**8. RECEIVING OF PETITIONS, PRESENTATIONS AND DEPUTATIONS**

**8.1 PETITIONS**

Nil

**8.2 PRESENTATIONS**

Nil

**8.3 DEPUTATIONS**

Nil

**9. APPLICATION FOR LEAVE OF ABSENCE**

Nil.

**10. CONFIRMATION OF MINUTES**

**10.1 ORDINARY COUNCIL MEETING HELD 20 JULY 2022**

No queries were raised in relation to this item.

**10.2 SPECIAL COUNCIL MEETING HELD 27 JULY 2022**

Clarification was sought in relation to:

- The total budget allocated to the building of the Shire Depot. The Chief Executive Officer advised of the total budget allocated over the financial years 21/22 and 22/23. The Executive Manager Engineering Services advised that the Depot project was divided into smaller packages, which made it more difficult to accurately calculate the potential cost before commencement. The additional costs are reflective of scoping adjustments and escalating prices.

**10.3 NOTES FROM COUNCIL FORUM MEETING HELD 10 AUGUST 2022**

No queries were raised in relation to this item.

Council Forum Meeting Notes  
10 August 2022



**11. ITEMS BROUGHT FORWARD FOR THE CONVENIENCE OF THOSE IN THE PUBLIC GALLERY**

Nil

**12. REPORTS OF COMMITTEE MEETINGS**

**12.1 NYOONGAR CULTURAL ADVISORY GROUP COMMITTEE MEETING HELD ON 14 MAY 2022**

Clarification was sought in relation to:

- If the meeting minutes from the committee meeting held on 14 MAY 2022 had already been received by council previously. The Chief Executive Officer will seek further clarification prior to council meeting on 17 AUGUST 2022.

Additional Comment

- Staff have confirmed the presented minutes have not been previously provided to Council for endorsement

**13. OFFICER REPORTS**

**13.1 CEO'S Office**

**13.1.1 Lease Agreement for Northam Pistol Club, Portion of Reserve 3303, 98 Clarke Street Northam**

Clarification was sought in relation to:

- How the Pistol Club were able to build a structure without shire approval.  
Executive Manager Development Services advised that the shire simply was not aware that it had been done. However once we became aware, we reached out to the Pistol Club to explain the breach and have been assisting them through the process of retrospective approval since. It was noted that the Pistol Club had not thought they needed approval as they were replacing a shed with a shed (like for a like).
- If there is any liability risk for the shire.  
Chief Executive Officer advised that in his view the exposure would be limited, however it would very much depend on the circumstance. The Shire was simply unaware that the works had been undertaken and as soon as we were made aware of the situation steps were taken to correct it.
- If the Pistol Club would need to follow the same procedure a rate payer would.

Executive Manager Development Services advised that the club would be able to apply for retrospective approval but would still need to comply with all necessary building requirements and specifications.

### 13.2 ENGINEERING SERVICES

#### 13.2.2 RFQ 10 of 2022 Spencers Brook Road Spray Seal & Asphalt Works

Clarification was sought in relation to:

- Why the cost for line marking is estimated as high as it is.  
Executive Manager Engineering Services advised that due to the length of the road plus how many lines will be painted plus the traffic management involved that is the estimated cost.
- If the Shire had previously looked at purchasing a line marking machine themselves.  
Chief Executive Officer advised that that they have purchased a line marking machine for the grass fields but not for roads.

### 13.3 DEVELOPMENT SERVICES

*Cr C R Antonio declared a "Financial" interest in item 13.3.1 – Proposed Amendment – Co-operative Bulk Handling, Leeming Road, Grass Valley as Cr Antonio's farming operation holds a \$2 share in CBH.*

*Cr C R Antonio left the meeting at 5.49pm*

#### 13.3.1 Proposed Amendment – Co-Operative Bulk Handling, Leeming Road, Grass Valley

Clarification was sought in relation to:

- If there was a way to catch the water runoff.  
Executive Manager Development Services advised that CBH addressed this in their drainage management plan.
- If CBH will assist to fix roads damaged by heavy truck loads.  
Executive Manager Development Services advised that this is covered by condition 3 in the officer recommendation.

*Cr C R Antonio returned to the meeting at 5.51pm*

*Cr M I Girak declared a "Proximity" interest in item 13.3.2 – Proposed Review of the Heritage List as Cr Girak's residential property is on the proposed Heritage List.*



Council Forum Meeting Notes  
10 August 2022



Cr A J Mencshelyi declared a "Impartiality" interest in item 13.3.2 – Proposed Review of the Heritage List as some property owners on the proposed Heritage List are known to Cr Mencshelyi.

Cr R W Tinetti declared a "Impartiality" interest in item 13.3.2 – Proposed Review of the Heritage List as some property owners on the proposed Heritage List are known to Cr Tinetti.

Cr M P Ryan declared a "Impartiality" interest in item 13.3.2 – Proposed Review of the Heritage List as one of the property owners on the proposed Heritage List are known to Cr Ryan.

Cr D A Hughes declared a "Impartiality" interest in item 13.3.2 – Proposed Review of the Heritage List as one of the property owners on the proposed Heritage List are known to Cr Hughes.

Cr J E G Williams declared a "Impartiality" interest in item 13.3.2 – Proposed Review of the Heritage List as some property owners on the proposed Heritage List are known to Cr Williams.

Cr C R Antonio declared a "Impartiality" interest in item 13.3.2 – Proposed Review of the Heritage List as some property owners on the proposed Heritage List are known to Cr Antonio.

Cr M I Girak left the meeting at 5.52pm

### 13.3.2 Proposed Review of the Heritage List

Clarification was sought in relation to:

- If the list provided includes all properties on the previous Heritage List. Executive Manager Development Services advised that the list shows the original properties plus the properties being recommended for addition.
- If the different wording in attachments on pages 128-129 will cause issues in future. Executive Manager Development Services advised that there will be no issues.
- If Dempster Home at Muresk Institute will need to come through the shire or if it is exempt due to being on government property. Executive Manager Development Services advised that Dempster Home would generally be exempt from the Shire of Northam approval process as it is State Government owned but would still be required to go through the internal government heritage process.
- If the Centenary Hill monument is included on the Heritage List. Executive Manager Development Services advised his understanding is that it is not currently included on the Municipal Heritage Inventory (MHI) (soon to be renamed Local Heritage Survey), however could be considered in the future.

Council Forum Meeting Notes  
10 August 2022



- If Pool Street bridge is included on to the Heritage list will this mean that the Shire is liable/obligated to fix the disrepair on the bridge. Executive Manager Development Services advised that as the Shire does not own the bridge, we will not be liable for the repair. However, having the bridge listed in the Heritage list may strengthen a case to obtain funding for recommissioning/repair.
- Will the Shire respond to the 5 submissions received regarding the Heritage list. Executive Manager Development Services advised that the Shire will respond to the submissions.

Cr M I Girak returns to the meeting at 6.02pm

### 13.4 CORPORATE SERVICES

#### 13.4.1 Accounts & Statements of Accounts 1 July 2022 to 31 July 2022

Clarification was sought in relation to:

- Clarification around payment for crash barriers on Mitchell Avenue and whether it actually belongs to the Shire or Main Roads. Executive Manager Engineering Services advised that Mitchell Ave belongs to the Shire, however that the project to fix the road has been 2/3 funded by Main Roads.
- Why the finance report was not provided in this agenda. Executive Manager Corporate Services advised that due to the heavy workload at this time of year the report was not ready as yet but will be provided in next month's agenda.

Council Forum Meeting Notes  
10 August 2022

Reference	Page #	Details Reference	Question	Query By	Answer	Answered By
EFT44357	185	Mad Dog Promo Key Rings	What are these for	Cr Tinetti	As per Community Safety Committee meeting motion 090, purchased key rings with community safety messages on them to distribute to members of the Community	Jaime
EFT44417	196	Grafton Electrics	Why so much	Cr Tinetti	This was to repair 21 lights on Minson Avenue that were not working, including five that needed replaced, (broken presumed by slingshot), an elevated platform was required to perform the works. Broken bulbs were replaced with LED bulbs	Shane
EFT44295	175	Macri Partners	Financial management review 21/22 - \$19800.00 - is this for part of the normal audit process?	Cr Williams	Yes, this is required to be carried out under the <i>Local Government Financial Management Regulations 1996</i> every three financial years, results will be presented to Council via the Audit Committee on the 25 August 2022	Colin
EFT44408	195	Country Comfort style Northam	Enterprise office chair - \$948.00 - is this for one chair only? Is there a maximum set for expenditure on staff chairs?	Cr Williams	This was for 3 office chairs, no maximum price is set for expenditure on office chairs, though in general they cost between \$300-\$400 each. The greater the weight rating the more expensive the chair as a general rule.	Colin
EFT44439	199	Promopal Pty Ltd	Umbrella canopies for Bilya Festival - \$6377.80 - is this for purchase or hire?	Cr Williams	Purchased for use at Bilya Festival, it is noted that the purchase of the umbrellas was less than hiring a marquee for the event.	Jo
EFT44449	201	The Book Shed	Paint lettering onto concrete at Bernard Park - \$1309.00 - for what?	Cr Williams	This was for the words, River Heart Land painted on the footpath out the front of the BK B as part of initiatives to attract people into the centre.	Jo
CEO C/card	211	N/a	Confirming the personal purchase of \$500.00 has been refunded?	Cr Williams	The request has been made for the refund, as yet still pending but should be deposited this month.	Colin
EMCOMS C/card	212	Harvey Norman	Oricut cutting machine and tools for \$468.00 - purchased for what please?	Cr Williams	Purchased by the events team to be used at events in general, it was initially used to cut the leaves for the reconciliation tree, other potential uses are signage/labelling etc.	Jo

Council Forum Meeting Notes  
10 August 2022



### 13.5 COMMUNITY SERVICES

#### 13.5.1 Nyoongar Cultural Advisory Group

Clarification was sought in relation to:

- The use of the meeting room at the Bilya Koort Boodja and adding a requirement for a welcome to country.  
Chief Executive Officer advised that the hope is that while any one can use the room, they will still leave the centre with more of an understanding of the indigenous culture.
- Would a person hiring the room have to pay someone to do a welcome to country.  
Chief Executive Officer advised that they would be able to do an acknowledgement to country at no cost.

### 14. MATTERS BEHIND CLOSED DOORS

#### RECOMMENDATION

Minute No: C.4525

Moved: Cr Ryan  
Seconded: Cr Hughes

That Council, in accordance with section 11.1(i) of the Shire of Northam Standing Orders Local Law 2018 and Section 5.23 (2) (b) (c) (d) of the Local Government Act 1995, meet behind closed doors to consider agenda items:

- 14.1 Lease of a portion of Reserve 44700 - as the matter relates to a contract which may be entered into.
- 14.2 Unauthorised Structure – A72 – as the matter relates to the personal affairs of a person and legal advice obtained or which may be obtained.

**CARRIED 10/0**

#### 14.1 LEASE OF A PORTION OF RESERVE 44700

Clarification was sought in relation to:

- If the area is larger but the rates stay the same.  
Chief Executive Officer advised that there will be no monetary change to the lease.

*Cr J E G Williams declared a "Proximity" interest in item 14.2 – Unauthorised Structure – A72 as a property that Cr Williams co-owns is located directly across a thoroughfare from the subject property.*

Cr J E G Williams left the meeting at 6.10pm

#### 14.2 UNAUTHORISED STRUCTURE – A72

Clarification was sought in relation to:

- If this individual completed the correct application process and had an engineer sign off on the structure in question, would it be allowed. Executive Manager Development Services clarified that the structure would need to meet all requirements and specifications of both building and planning departments.
- If it is possible that the individual needs assistance through the process. Executive Manager Development Services advised that this situation has been ongoing for 4 years and all reasonable assistance has been offered to the individual.
- If the structure was relocated to a rural property would that remove the issue. Executive Manager Development Services advised that this could address the planning issue but not building code matters unless the structure was used as a non-habitable building or significantly altered.
- Should the Shire consider the inclusion of a flyer with the rates with information for rate payers regarding not building without a permit. Chief Executive Officer advised that as the number of issues in Northam are relatively minor, it is not considered to be a significant enough matter to warrant more information to accompany the rate notice, however some promotion could occur through other means.
- Could this building be classified as a Granny Flat. Executive Manager Development Services advised that even if it was, granny flats are still subject to the same building requirements as a habitable dwelling. As these buildings are becoming more popular, how do the shire plan to address it.
- Executive Manager Development Services advised that there are a number of companies that applied and been approved to build small modular buildings that comply with Shire specifications. Council has an existing policy in place with respect to Transportable buildings and provided they comply with that policy approvals can be issued.

Colin Young left the meeting at 6.20pm

Colin Young returned to the meeting at 6.23pm

Council Forum Meeting Notes  
10 August 2022



Cr J E G Williams returned to the meeting at 6.36pm

**RECOMMENDATION / COUNCIL DECISION**

**Minute No:** C. 4526

**Moved:** Cr Mencshelyi

**Seconded:** Cr Ryan

**That Council move out from behind closed doors.**

**CARRIED 10/0**

**15. MOTIONS OF WHICH PREVIOUS NOTICE HAS BEEN GIVEN**

**15.1 FENCED DOG PARK**

Clarification was sought in relation to:

- Would the petition be accepted with the majority of the signers not being located in Northam.  
Chief Executive Officer advised that this document would not be recognised as a formal petition as it does not comply with the requirements under the Shire of Northam Standing Order local law. The proponent was advised of this.
- Is a fenced dog park part of any identified future plans of the Shire.  
Executive Managed Development Services advised that it is not currently in a recognised plan, but discussions have been held previously.

**16. URGENT BUSINESS APPROVED BY DECISION**

Nil.

**17. DECLARATION OF CLOSURE**

The Shire President, Cr C R Antonio declared the meeting closed at 6.40pm.

## 11. ITEMS BROUGHT FORWARD FOR THE CONVENIENCE OF THOSE IN THE PUBLIC GALLERY

The Shire President, Cr C R Antonio brought agenda item 13.3.1 – Proposed Amendment – Co-Operative Bulk Handling, Leeming Road, Grass Valley forward.

*Cr C R Antonio declared a "Financial" interest in item 13.3.1 – Proposed Amendment – Co-operative Bulk Handling, Leeming Road, Grass Valley as Cr Antonio's farming operation holds a \$2 share in CBH.*

*Cr R W Tinetti declared a "Impartiality" interest in item 13.3.1 – Proposed Amendment – Co-Operative Bulk Handling, Leeming Road, Grass Valley as some of the farmers affected by use of Leeming Road are known to Cr Tinetti.*

*Cr C R Antonio left the meeting at 5.45pm and the Deputy Shire President, Cr M P Ryan took the chair.*

### 13.3.1 Proposed Amendment – Co-Operative Bulk Handling, Leeming Road, Grass Valley

<b>Address:</b>	Lots 9002, 18, 19 and 20 Leeming Road, Grass Valley (Avon Industrial Park)
<b>Owner:</b>	Western Australian Land Authority
<b>Applicant:</b>	Co-operative Bulk Handling Ltd
<b>File Reference:</b>	P21083.2 / A16428
<b>Reporting Officer:</b>	Jacky Jurmann, Manager Planning & Environment
<b>Responsible Officer:</b>	Chadd Hunt, Executive Manager Development Services
<b>Officer Declaration of Interest:</b>	Nil
<b>Voting Requirement:</b>	Simple
<b>Press release to be issued:</b>	No

#### BRIEF

An application has been received to amend the development approval (ref: P21083) to construct an additional 3 open bulkheads at CBH's temporary grain receival and handling facility in the Avon Industrial Park.

#### ATTACHMENTS

Attachment 1: Application documents.

#### A. BACKGROUND / DETAILS

### Background

Council at its Ordinary Meeting held on 21 July 2021 resolved to grant development approval for the construction of a temporary grain receival and storage facility at Lots 9002, 18, 19 and 20 Leeming Road, Grass Valley.

The existing development currently consists of six open bulkheads, temporary sample hut, weighbridge and staff amenities.

The original development approval was granted for a temporary period of 12 months. A 24 month extension was granted by Council at last month's OCM to enable CBH to continue to provide additional grain storage and to plan for the development of their new permanent facility on the site.

### Application Details

CBH is now seeking approval to construct an additional three open storage bulkheads with a capacity of 123,140 tonnes to provide emergency storage to cater for the current forecast of another significant harvest and the large amount of carryover grain from the previous season.

The existing temporary weighbridge, sample hut and staff facilities will continue to be utilised. New access roads and stormwater detention are also proposed as part of this application.

## **B. CONSIDERATIONS**

### **B.1 Strategic Community / Corporate Business Plan**

Theme Area: Governance & Leadership

Outcome: Residents and other stakeholders are actively listened to and their input into decision-making processes is valued.

Objective: Decisions made by the Shire of Northam are communicated and the reasoning clearly articulated to residents and stakeholders.

### **B.2 Financial / Resource Implications**

There are no financial / resource implications associated with this proposal. The relevant application fee has been paid.

### **B.3 Legislative Compliance**

Clause 77(1) of the *Planning and Development (Local Planning Schemes) Regulations 2015* enables an owner to request the local government to do any or all of the following:

- (a) to amend the approval so as to extend the period within which any development approved must be substantially commenced;
- (b) to amend or delete any condition to which the approval is subject;



- (c) to amend an aspect of the development approved, which if amended, would not substantially change the development approved;
- (d) to cancel the approval.

The application to construct an additional three bulkheads can be considered under the provisions of sub-clause (c) as it is amending an aspect of the development approval that does not substantially change the development approval (i.e. a temporary grain receival and handling facility).

#### **B.4 Policy Implications**

There are no policy implications associated with this proposal.

#### **B.5 Stakeholder Engagement / Consultation**

##### Stakeholder Engagement

The Applicant has consulted with Main Roads WA who have advised that they have no objections to the approval of the three additional bulkheads.

##### Consultation

The development proposal did not require any public consultation as it is a 'D' (discretionary) use under the provisions of the Northam Local Planning Scheme No. 6.

#### **B.6 Risk Implications**

<b>Risk Category</b>	<b>Description</b>	<b>Rating (likelihood x consequence)</b>	<b>Mitigation Action</b>
Financial	Nil	Nil	Nil
Health & Safety	Nil	Nil	Nil
Reputation	Nil	Nil	Nil
Service Interruption	Nil	Nil	Nil
Compliance	Conditions not being complied with.	Minor (2) x Unlikely (2) = Low (4)	Monitor conditions for compliance.
Property	Nil	Nil	Nil
Environment	Nil	Nil	Nil

#### **B.7 Natural Environment Considerations**

Not applicable.

### **C. OFFICER'S COMMENT**

The assessment of the original application identified the main issues to be traffic generation and stormwater management.

### Traffic

A Traffic Impact Assessment has been submitted with the application to provide an assessment of the increase in traffic movements as a result of the additional storage, which will increase from 251kt to 374kt.

The TIA indicates that the truck movements for the upcoming season will exceed the existing capacity and last year's truck movements during harvest. The intent of the additional emergency storage is to reduce the outgoing movements during harvest as shown in the scenarios in the following table from page 3 of the TIA:

Item	2021/22 Harvest	2022/23 without emergency	2022/23 with emergency
Tonnes Received (t)	109,597	231,021	231,021
Truck Payload (tonnes)	50.1	50.1	50.1
Total Harvest Reveal Movements	2,188	4,611	4,611
Total Harvest Out Loading Movements		2,310	-
Total Harvest Movement	2,188	6,922	4,611

CBH have consulted Main Roads WA regarding the proposed development and resulting additional traffic generation. Main Roads have raised no objections to approval of the development relating to potential impacts from the additional truck movements on Great Eastern Highway and the intersection with Leeming Road.

Shire Officers agree with the Main Roads assessment regarding the operational phase of the development. Leeming Road is capable of catering for additional heavy vehicle movements and is constructed to acceptable standard for accessing and egressing the site from an easterly direction, which is the direction the TIA indicates the harvest traffic will be generated.

However, the TIA does not provide an assessment of the traffic movements associated with the construction phase of the development. CBH Officers have advised that approximately 20,000 tonnes of gravel will be required to construct the additional bulkheads, which equates to approximately 350 truck movements importing gravel onto the site from a local supplier.

Previously the gravel was sourced from a local gravel pit on Gentle Road entering the site from an easterly direction, which resulted in a number of

complaints being received regarding the impacts on the condition of Grass Valley South Road. To better understand and manage the number, frequency and impact of the truck movements during the construction phase, a condition is recommended requiring submission and approval of a Construction Management Plan.

#### Stormwater

The development application also contains a Stormwater Management Plan, which proposes the construction of an additional onsite drainage basin to manage stormwater runoff from the proposed bulkheads and associated accessways to retain manage stormwater on-site.

#### Future Development

CBH have indicated that a masterplan for the site is currently being prepared and that they are keen to discuss their plans with Shire Officers in the near future.

Scheme Amendment No. 16 that proposes to rezone portions of the land to General Industry to facilitate the future development of the site by CBH, including construction of a rail spur, is currently with the Western Australian Planning Commission for final approval.

#### Conclusion

The approval of this application will not substantially change the intent of the original development approval to develop the land for the purposes of a temporary grain receipt and storage facility, and is acceptable to consider under the provisions of clause 77 of the Deemed Provisions.

The application is recommended for approval subject to the reimposition of the original conditions of approval, except where varied by this amendment including the requirement for approval of a Construction Management Plan.

### **RECOMMENDATION / COUNCIL DECISION**

**Minute No: C.4532**

**Moved: Cr Mencshelyi**

**Seconded: Cr Hughes**

**That Council resolves to:**

- 1. Accept that the development application reference P21083.2 as detailed on the development application form dated 27 August 2020 is appropriate for consideration in accordance with regulation 77 of the *Planning and Development (Local Planning Schemes) Regulations 2015*;**

2. **Approve** the development application reference P19080.1 as detailed on the development application form dated 28 July 2022 and accompanying plans:

- Site Plan – 801-ENG-CI-DCO-0015; Rev. A;
- Standard Elevation Drawing – S119-ENG-ST-DGA-0003; Rev. 0;
- Standard DOG Drawing – S040-ENG-ME-DGA-0010; Rev. 0;
- Stormwater Management Plan – Shawmac dated 27/07/2022;
- Traffic Impact Assessment – Shawmac dated 27/07/2022.

in accordance with clause 68 of Schedule 2 (Deemed Provisions) of the Planning and Development (Local Planning Schemes) Regulations 2015 and the provisions of the Shire of Northam Local Planning Scheme No. 6, for the proposed amendments to the approved temporary grain receival and storage facility at Lot 9002 Leeming Road, Grass Valley.

3. **Add** an additional condition (No. 9) of development approval (ref: P21083) dated 21 July 2021 and as amended on 20 July 2022 (P21083.1) to read:

“A Construction Management Plan shall be submitted for approval to the Shire of Northam prior to commencement of works. The Construction Management Plan shall address dust, noise, waste management, storage of materials, traffic management and site safety/security. The Construction Management Plan is to be complied with for the duration of the construction of the development.”

4. **Advise** the Applicant that all other conditions of the development approval (P21083) dated 21 July 2021 and as amended on 20 July 2022 (P21083.1) remain unchanged.

**CARRIED 9/0**

Cr C R Antonio returned to the meeting at 5:50pm and resumed the chair.

Mr Grant Park left the meeting at 5:50pm.

## Attachment 1: Application documents



28 July 2022

Chadd Hunt, Executive Manager Development Services  
Shire of Northam  
Via email: [emds@northam.wa.gov.au](mailto:emds@northam.wa.gov.au)

Dear Chadd,

### **LOT 9002 LEEMING ROAD, GRASS VALLEY, WA 6403 STORAGE ADDITIONS TO EXISTING GRAIN HANDLING & STORAGE FACILITY**

CBH is seeking development approval from the Shire of Northam for proposed additions (storage bulkheads) to an existing grain handling and storage facility located at Lot 9002 Leeming Road, Grass Valley. The subject application is prepared in accordance with Schedule 2 (Deemed Provisions) of the Planning and Development (Local Planning Schemes) Regulations 2015 and the Shire of Northam Local Planning Scheme No. 6.

#### **Site Details**

Lot 9002 Leeming Road, Grass Valley (subject site) is located within the Avon Industrial Park as shown in Figure 1 below.



Figure 1: Location Plan

### Background

At the 21 July 2021 Ordinary Council Meeting, Council resolved to approve an application to obtain development approval to construct a temporary grain receival and storage facility at its Meenaar site located within the Avon Industrial Park. Condition 2 of this development approval limited the approval to a period of 12 months from the date of the commencement of the approved use.

CBH lodged a further development application to amend this condition 2 which time limited the use of the facility to 12 months. At the 20 July 2022 Ordinary Council Meeting, Council resolved to approve the amended development application for the continued use of the temporary grain receival and storage facility for a further 24 months.

As you know, CBH had a record harvest last year where its existing storage infrastructure was not enough to keep up with the record crop. The Shire of Northam assisted CBH with this storage shortfall through approving this development application for open storage bulkheads at the Meenaar CBH site.

Given the current forecast of another significant harvest for FY22/23 and the large amount of carryover grain that remains at many of our receival sites, we have identified the potential need to build emergency storage at identified sites with forecasted storage deficits for this harvest. The Meenaar CBH site is one of these sites where there is a strong likelihood that emergency storage could be needed. As such CBH is seeking development approval from the Shire of Northam for an additional three storage bulkheads.

### Context and Land Use

The subject land is located within the Shire of Northam. Access to the site is from the south via Leeming Road which is an access road under the control of the Shire of Northam. The subject site is zoned 'general industry' under the Shire's Local Planning Scheme No. 6. The subject site is surrounded by 'rural' zoned land to the south and west and land immediately east of the subject site is also zoned 'general industry'. The site is adjacent to a parks and recreation reserve to the north than buffers land reserved as railway.

### Town Planning Considerations

The proposed development is considered to be consistent with Clause 68 of Schedule 2 (Deemed Provisions) of the Planning and Development (Local Planning Schemes) Regulations 2015 and the provisions of the Shire of Northam Local Planning Scheme No. 6. The subject land is zoned 'general industry' under the Shire's Local Planning Scheme No. 6. The development proposed does not require any public consultation as it is a 'D' (discretionary) use under the provisions of Local Planning Scheme No. 6.

Through their assessment of the previous application, the Shire of Northam identified the main issues to be traffic generation and stormwater management. Both issues were satisfactorily addressed by CBH and conditions of development approval were able to ensure that there were no adverse effects on the locality. CBH would be supportive of similar conditions being imposed on any subsequent development approval to ensure any potential impacts continue to be mitigated appropriately as it is noted that there have been specific concerns in relation to the impact of the facility on both Leeming and Grass Valley South roads. Notwithstanding a Stormwater Management Plan and Traffic Impact Statement have been provided with lodgement of the application to assist with the Shire's consideration of the proposal.

### Traffic Management

As CBH are expecting another significant harvest in 2022/23 in order for our network to be able to service growers and cope with the task we have identified sites throughout the network where emergency storage is required. We propose to construct 3 new temporary OBH's with nameplate storage capacity of 123kt at Meenaar. This will increase the total site storage capacity from 251kt to 374kt. Note that the total site storage capacity includes 109kt which is expected to be held at the site as carryover grain from the prior year. The following notes are applicable to the Shire's consideration of storage capacity and its traffic impacts:

- Listed capacity is also not an accurate representation of what can be received due to operational intricacies that impact the sites. This namely because of "loss by division/loss by commodity" where multiple grain types are required to be stored/tarped within the same OBH, resulting in less efficient storage.
- The max case does not take into account the carryover amounts which refer to the amounts that will be retained/store in the storage from the prior year.
- Thereby reducing the effective storage amount for the current period by the carryover amount, our carryover estimate leading in to the 2022/23 harvest is 109kt.
- This means that the effective max storage capacity for the 2022/23 harvest with the proposed emergency storage build is 265kt.
- The effect of constructing the emergency storage is that out loading movements during the busy harvest period to keep the site open for grower receivals are eliminated.

Based on the average payload of 50.1t, the table below provides an estimate of the FY22/23 harvest period truck movements, with and without the proposed emergency OBH and with comparison to the previous year's volumes and movements.

Item	2021/22 Harvest	2022/23 without emergency	2022/23 with emergency
Tonnes Received (t)	109,597	231,021	231,021
Truck Payload (tonnes)	50.1	50.1	50.1
Total Harvest Receival Movements	2,188	4,611	4,611
Total Harvest Out Loading Movements		2,310	-
Total Harvest Movement	2,188	6,922	4,611

As shown, the movements for FY22/23 regardless of the emergency TBH construction are expected to exceed the existing capacity and last year's truck movements, but the construction of the emergency TBH allows movements to be reduced in comparison to the scenario where the emergency TBH is not installed for the 2022/2023 harvest. Further detail on the impact of roads is provided under Section 4.2 of the Traffic Impact Statement that is provided in conjunction with lodgement of this application.

#### Stormwater Management

An onsite drainage basin will be constructed that caters for a 5-year ARI event with all stormwater runoff from the proposed bulkheads and associated accessways directed to this drainage basin system where all surface water will be detained on-site up to the 5-year ARI event. A Stormwater Management Plan has been provided in conjunction with lodgement of the application for the Shire's consideration.

#### Noise & Dust Management

CBH shall ensure that noise from the specification and installation of any mechanical equipment as well as traffic and construction noise does not exceed levels prescribed in the *Environmental Protection (Noise) Regulations 1997*, when it is received at a neighbouring property. CBH undertakes frequent noise and dust monitoring across its sites to ensure that dust and noise levels are measured and are mitigated whenever there is an exceedance.

#### **Conclusion**

The proposed addition is aligned with the planning framework for the area specifically the general industry zone and it is not considered to result in any new amenity impacts to the surrounding area. CBH respectfully requests the Application for Development Approval is considered by the Shire of Northam expeditiously given the straightforward nature of the application, that it is already constructed and its general compliance with the Shire's planning framework. Should you have any question in relation to the details provided in this submission, please contact Timothy Roberts on 9216 6061 or [timothy.roberts@cbh.com.au](mailto:timothy.roberts@cbh.com.au)

Yours Sincerely,



**Timothy Roberts**  
Specialist – Regulatory Approvals Adviser



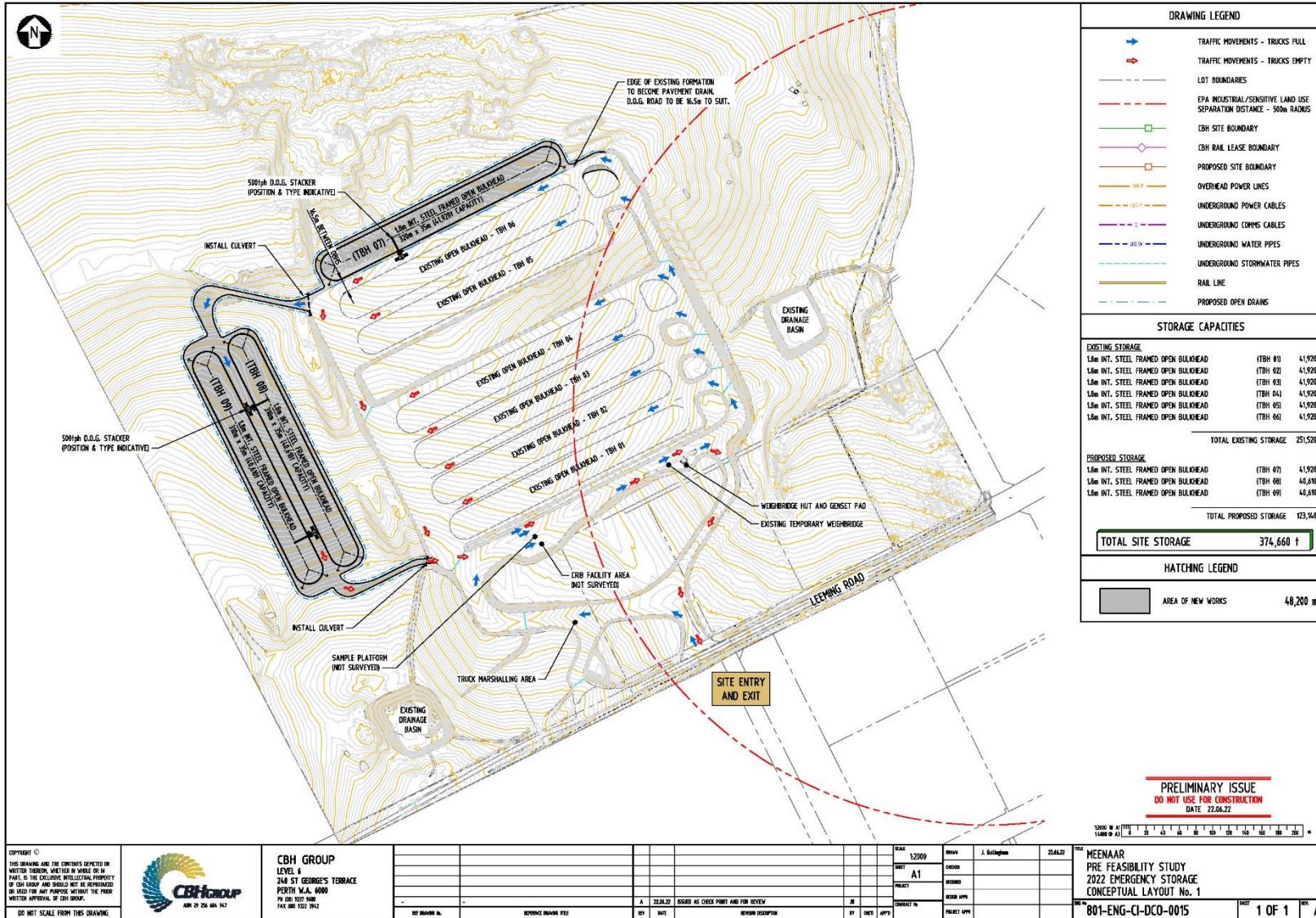

Copyright ©  
 THIS DRAWING AND THE CONTENTS HEREIN OR ANY PART THEREOF, WHETHER IN WHOLE OR IN PART, IS THE EXCLUSIVE INTELLECTUAL PROPERTY OF CBH GROUP AND SHOULD NOT BE REPRODUCED OR USED FOR ANY PURPOSE WITHOUT THE WRITTEN APPROVAL OF CBH GROUP.

DO NOT SCALE FROM THIS DRAWING



CBH GROUP  
 LEVEL 4  
 244 ST GEORGE'S TERRACE  
 PERTH W.A. 6000  
 PH 081 937 7900  
 FAX 081 702 7912

REV	DATE	BY	CHKD	APPD	DESCRIPTION
1	22.08.22	JG	JG		ISSUED AS CHECK POINT AND FOR REVIEW

DATE	12/2020	DRAWN	J. Gillingham	22.08.22
SHEET	A1	DESIGN		
PROJECT		ISSUED		
DESIGN APPR		PROJECT APPR		

MEENAAR  
 PRE FEASIBILITY STUDY  
 2022 EMERGENCY STORAGE  
 CONCEPTUAL LAYOUT No. 1

801-ENG-CI-DCO-0015

SHEET 1 OF 1

REV. A

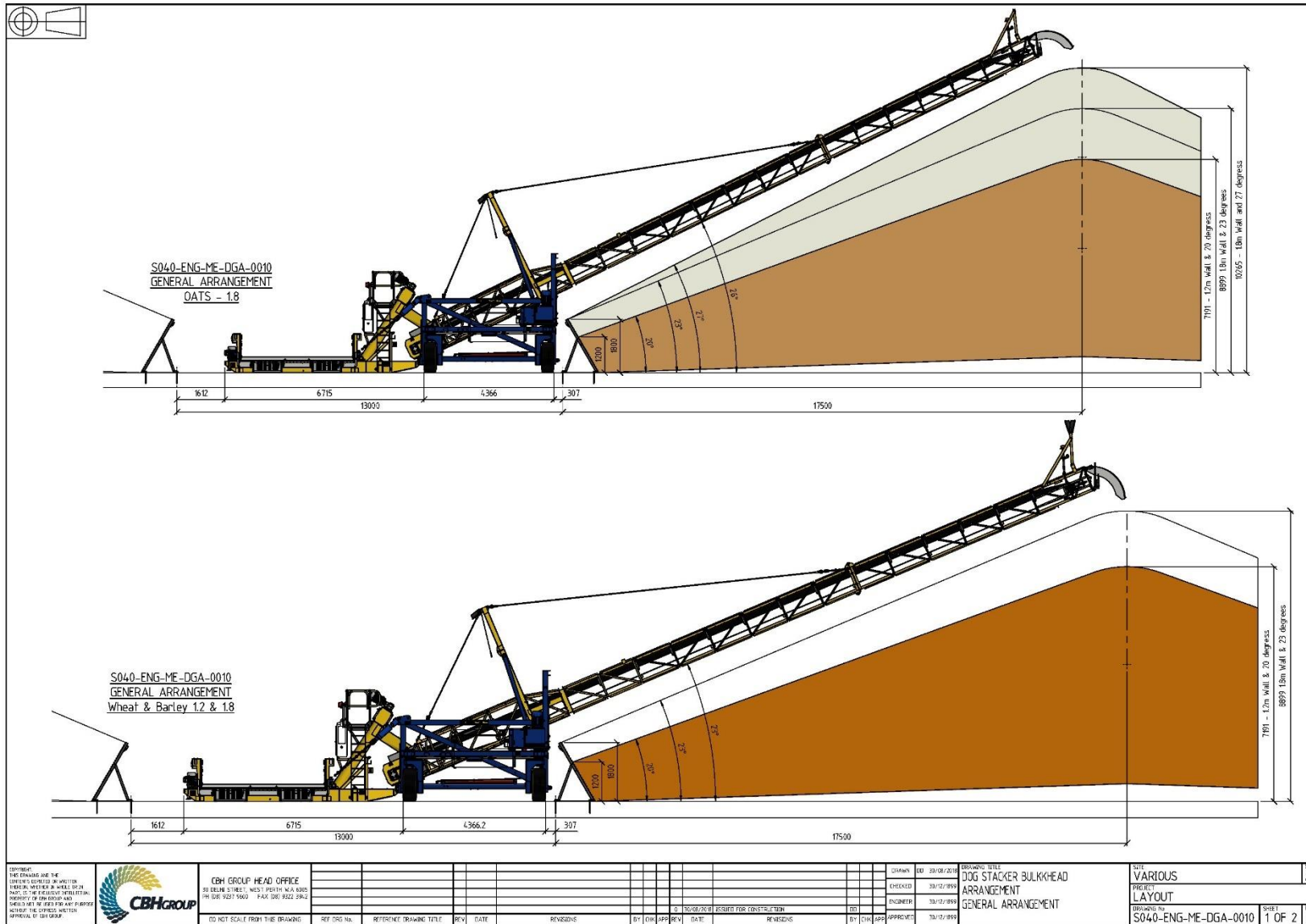

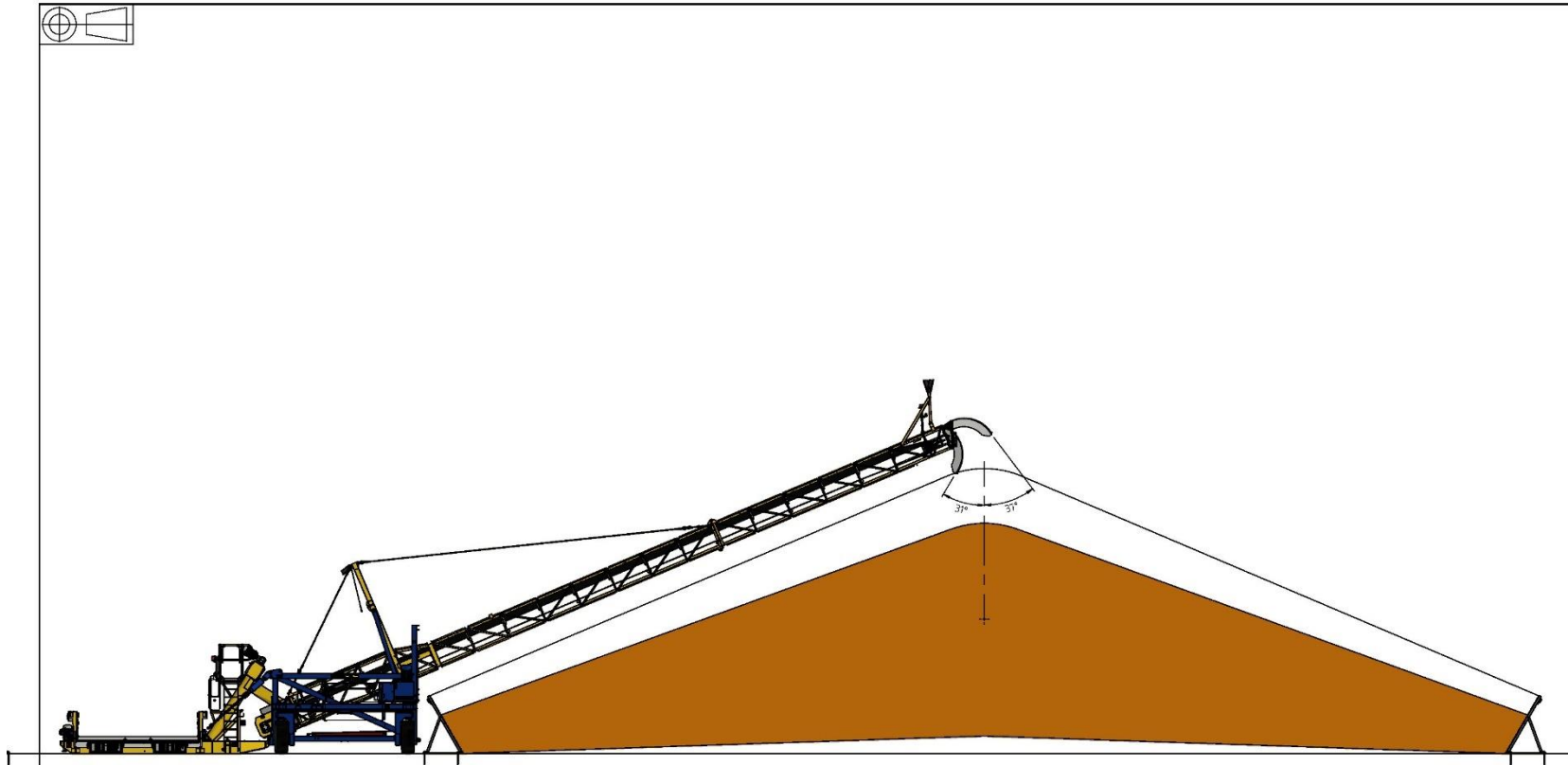

S040-ENG-ME-DGA-0010  
 GENERAL ARRANGEMENT

DISCLAIMER:  
 THE DRAWING AND THE  
 SYSTEMS DESCRIBED IN THIS  
 DRAWING, WHETHER IN WHOLE OR IN  
 PART, IS THE PROPERTY OF CBH GROUP  
 AND IS NOT TO BE REPRODUCED OR  
 TRANSMITTED IN ANY FORM OR BY ANY  
 MEANS, ELECTRONIC OR MECHANICAL,  
 INCLUDING PHOTOCOPYING, RECORDING,  
 OR BY ANY INFORMATION STORAGE  
 AND RETRIEVAL SYSTEM, WITHOUT THE  
 EXPRESS WRITTEN  
 PERMISSION OF CBH GROUP.



**CBH GROUP HEAD OFFICE**  
 35 DELANEY STREET, WEST PERTH, W.A. 6150  
 PH: (08) 9427 5900 FAX: (08) 9422 2962

DO NOT SCALE FROM THIS DRAWING

REV	DATE	REVISIONS	BY	CHK	APP	REV	DATE	REVISIONS	BY	CHK	APP

DRAWN: 000 23/08/2018  
 CHECKED: 33/12/1999  
 ENGINEER: 33/12/1999  
 APPROVED: 33/12/1999

DESIGNER FOR CONSTRUCTION: 000  
 APPROVED:

DRAWING TITLE	SHEET NO.	TOTAL SHEETS
DOG STACKER BULKHEAD ARRANGEMENT GENERAL ARRANGEMENT	2	0

PROJECT	DATE	SHEET	TOTAL SHEETS
VARIOUS LAYOUT		2 OF 2	0

REF: S040-ENG-ME-DGA-0010

DATE: 2 OF 2

NO. OF SHEETS

NO. OF SHEETS

NO. OF SHEETS

NO. OF SHEETS

NO. OF SHEETS

NO. OF SHEETS

NO. OF SHEETS

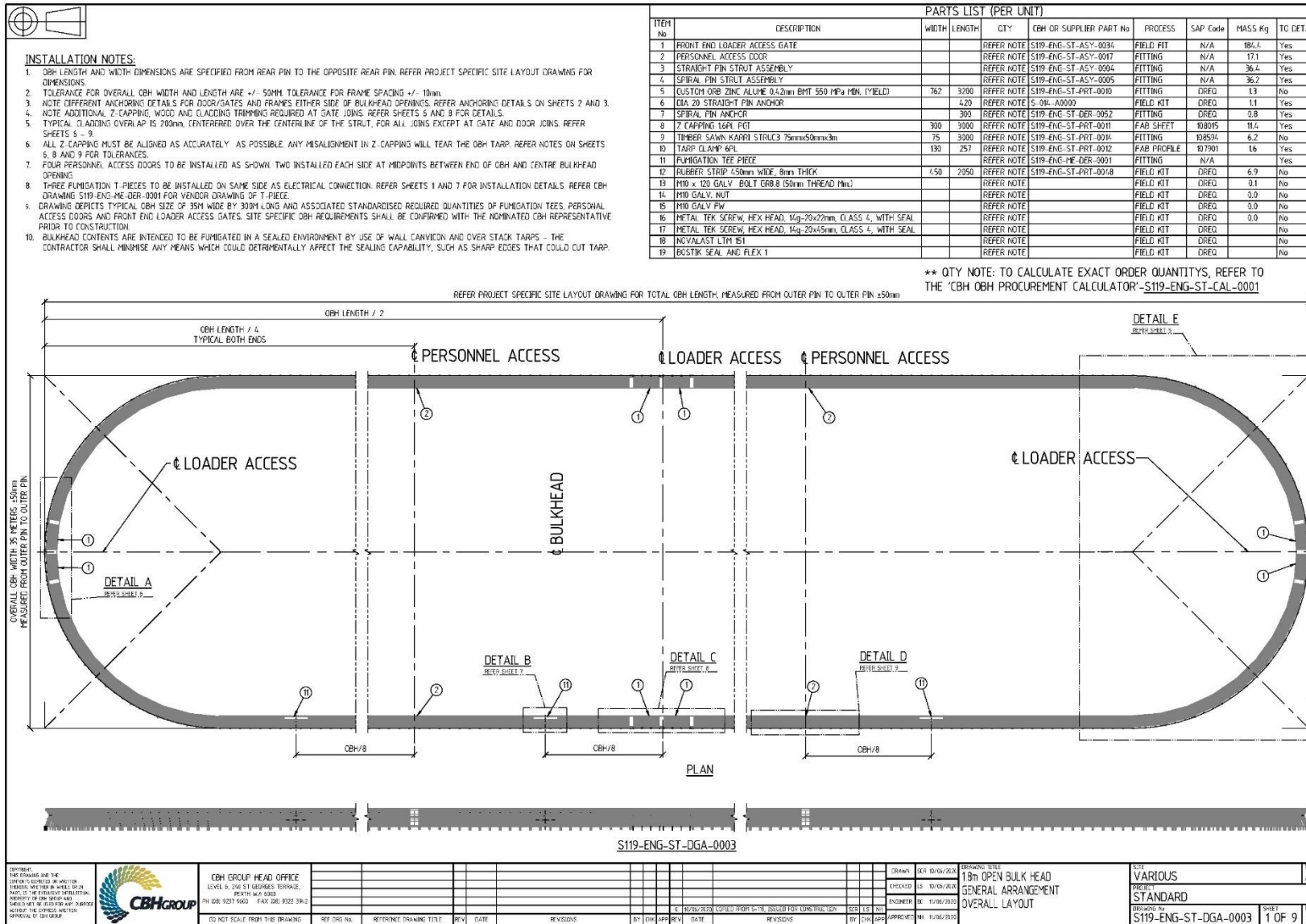

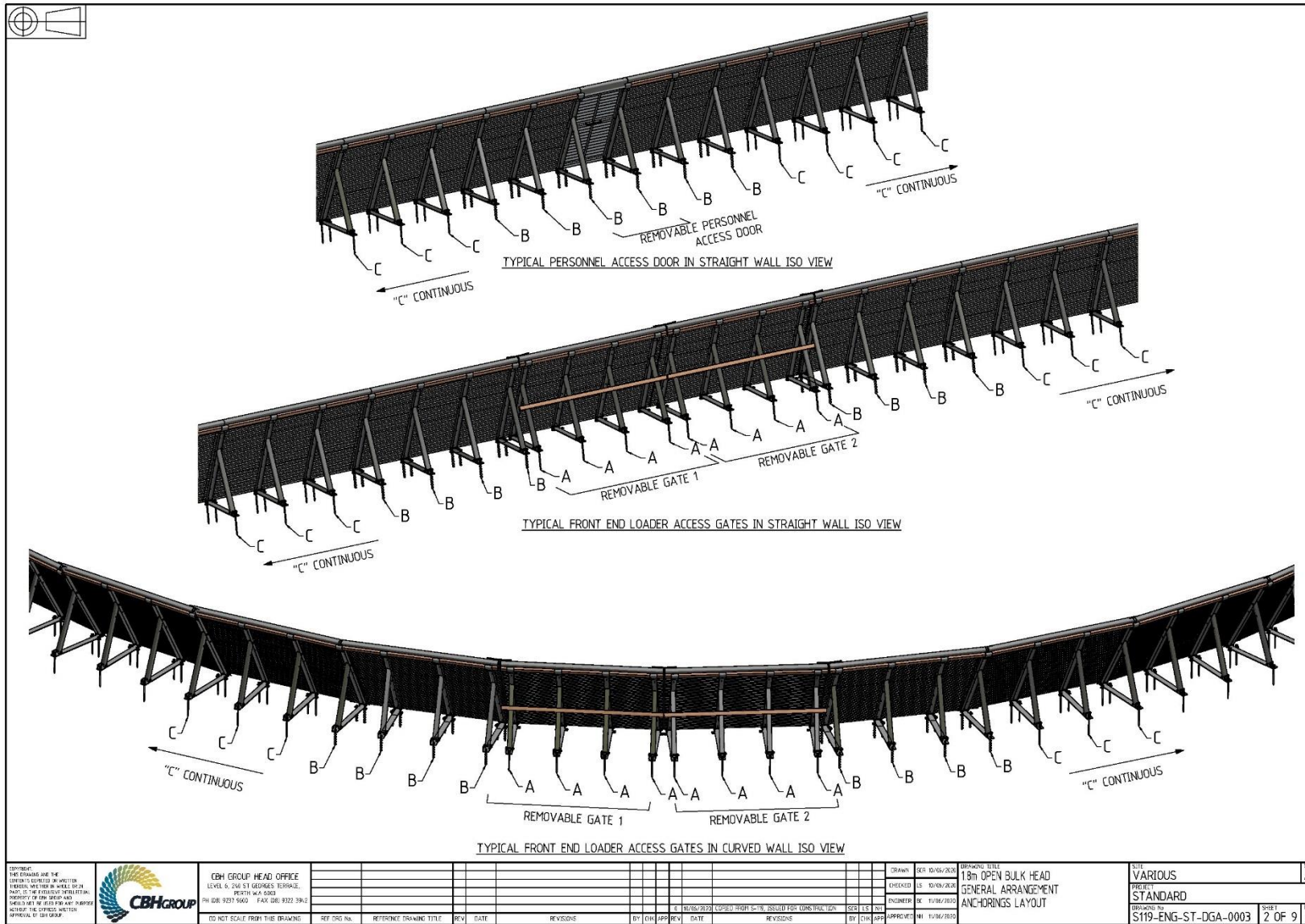

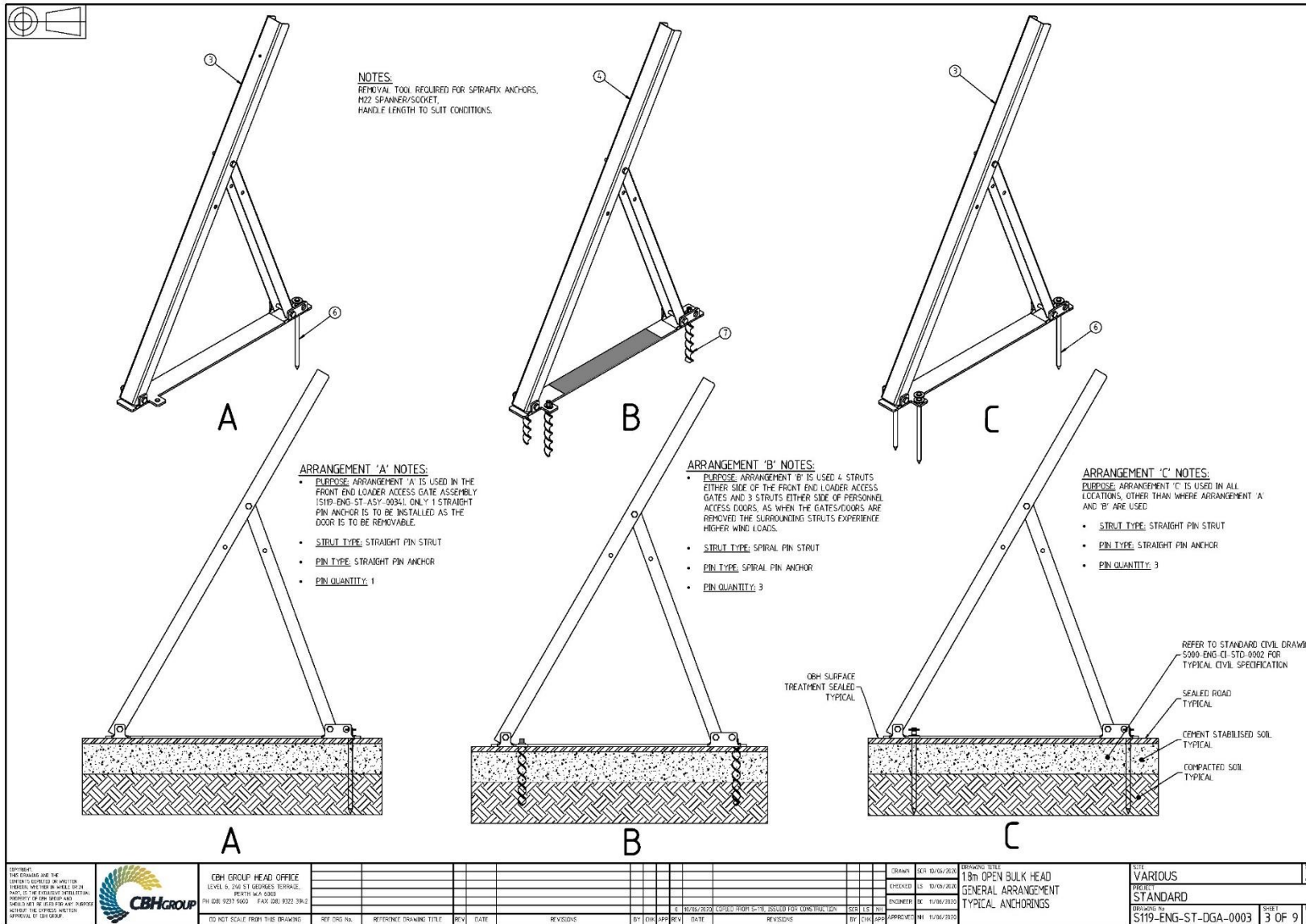

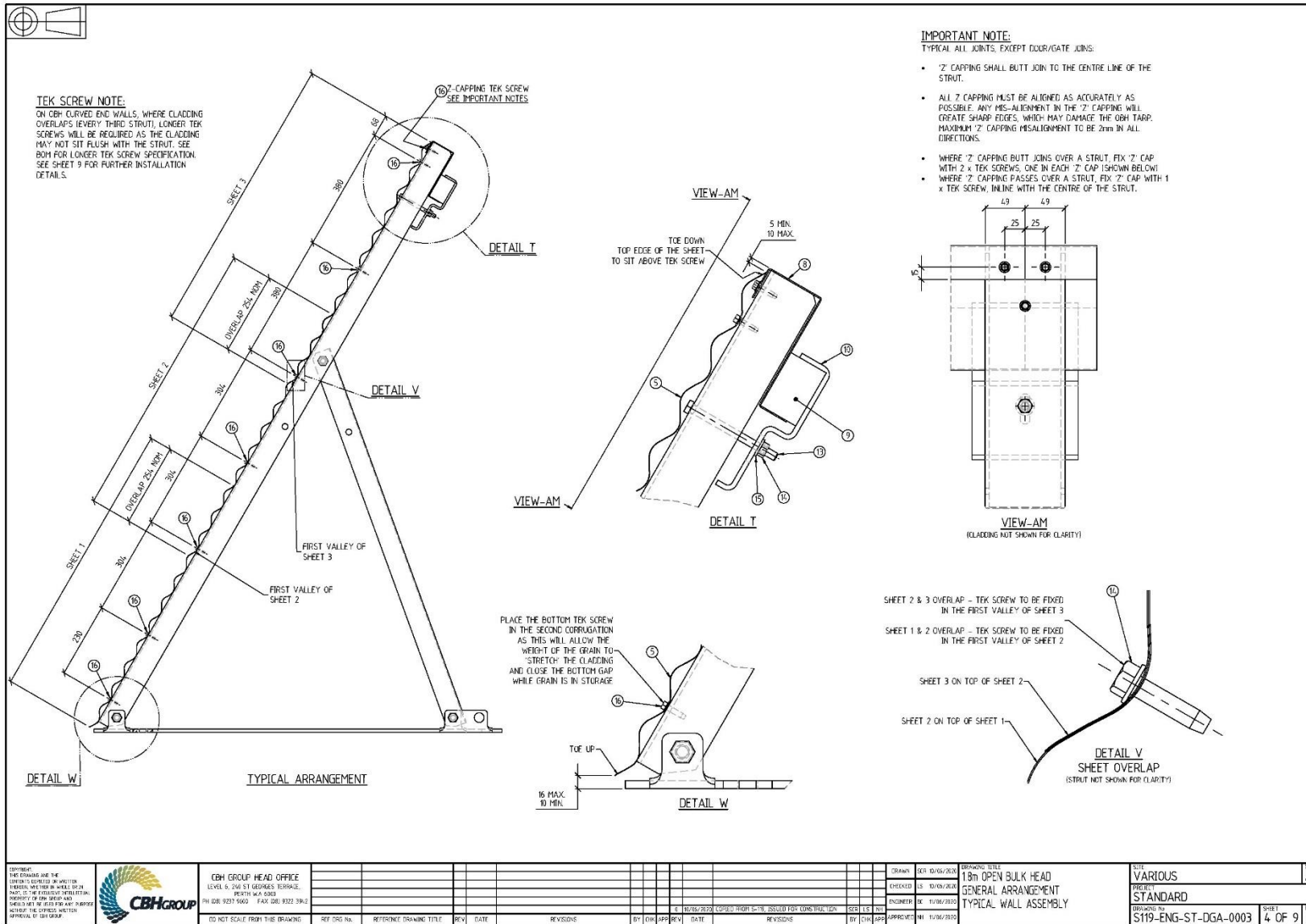

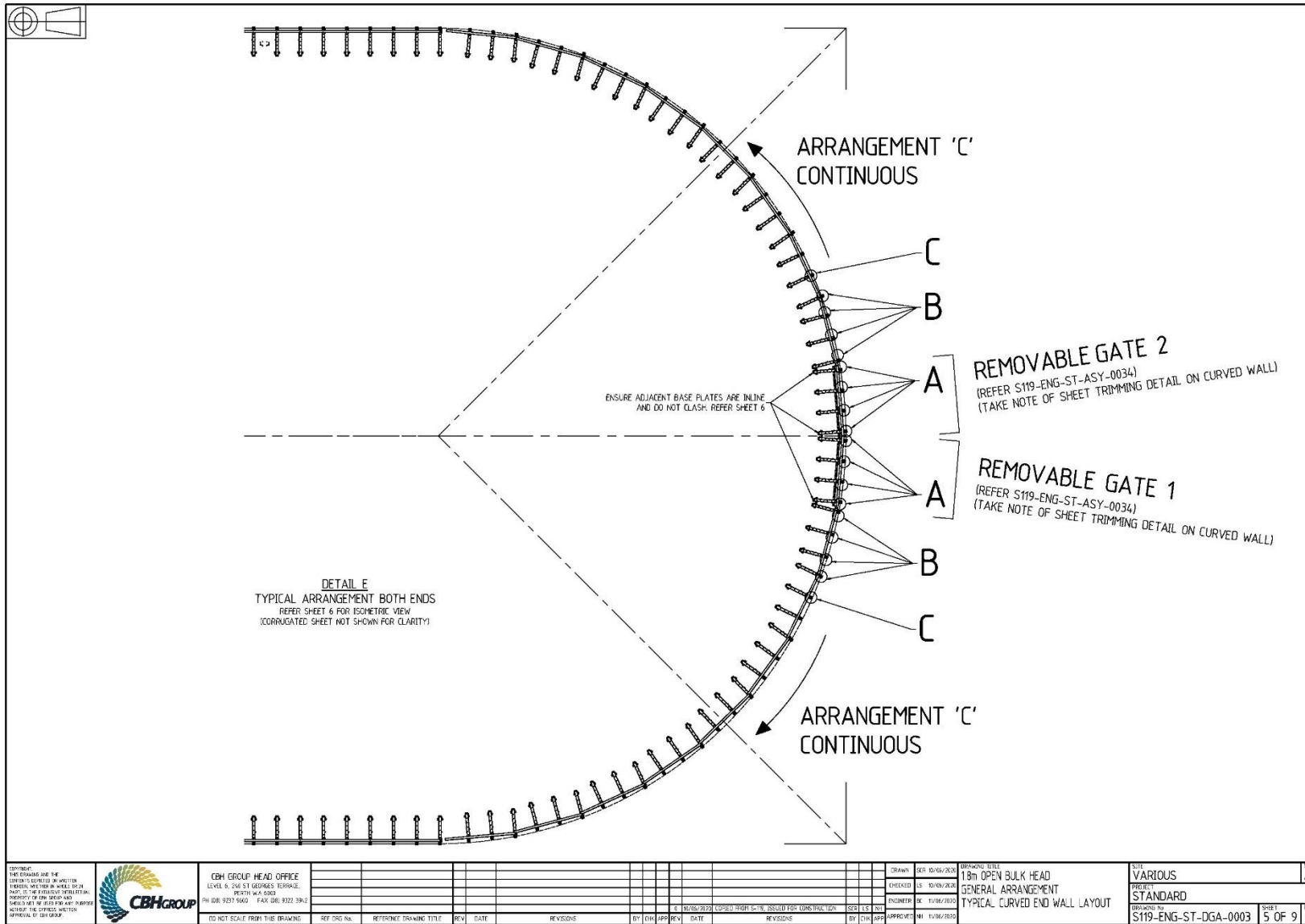



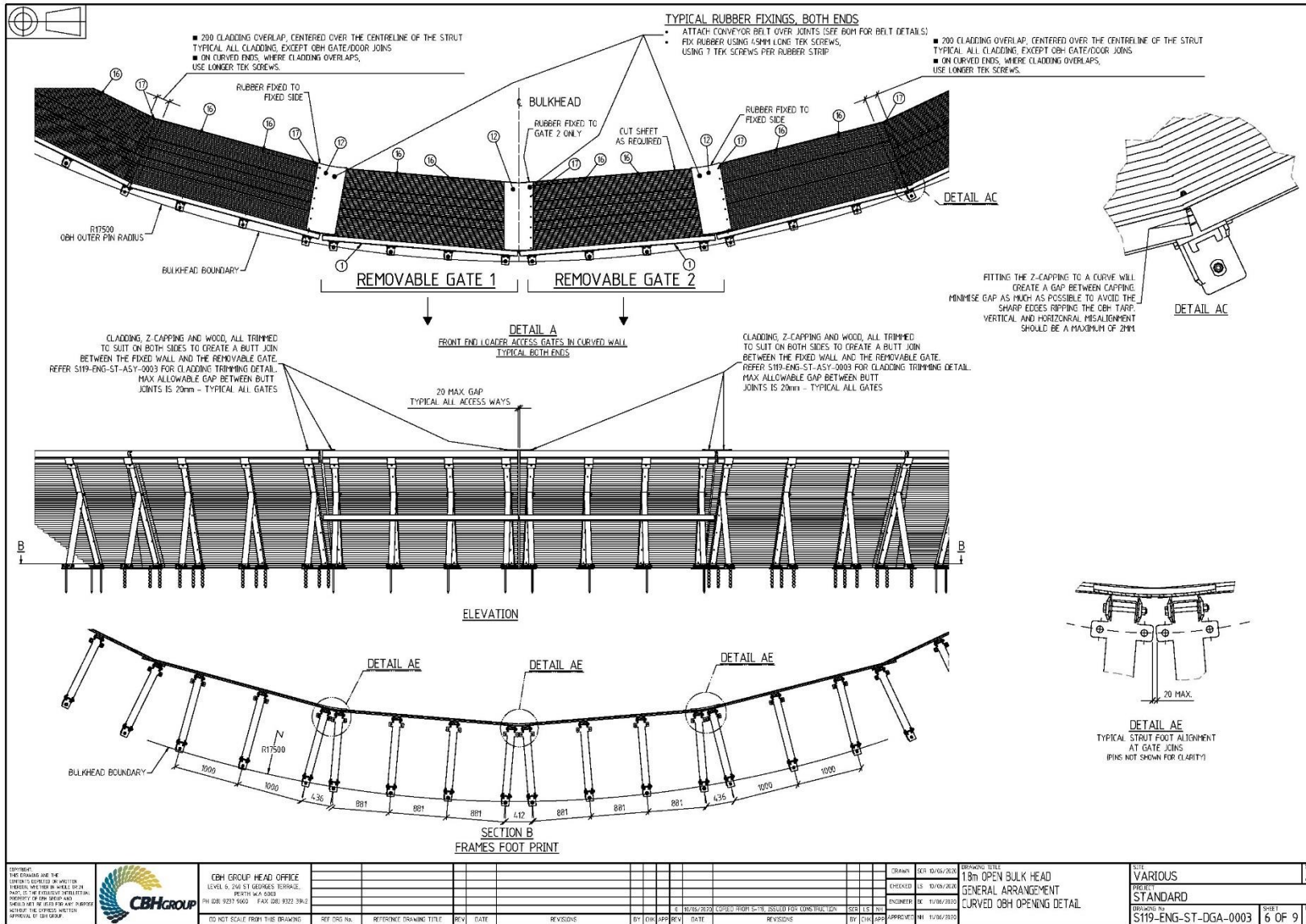

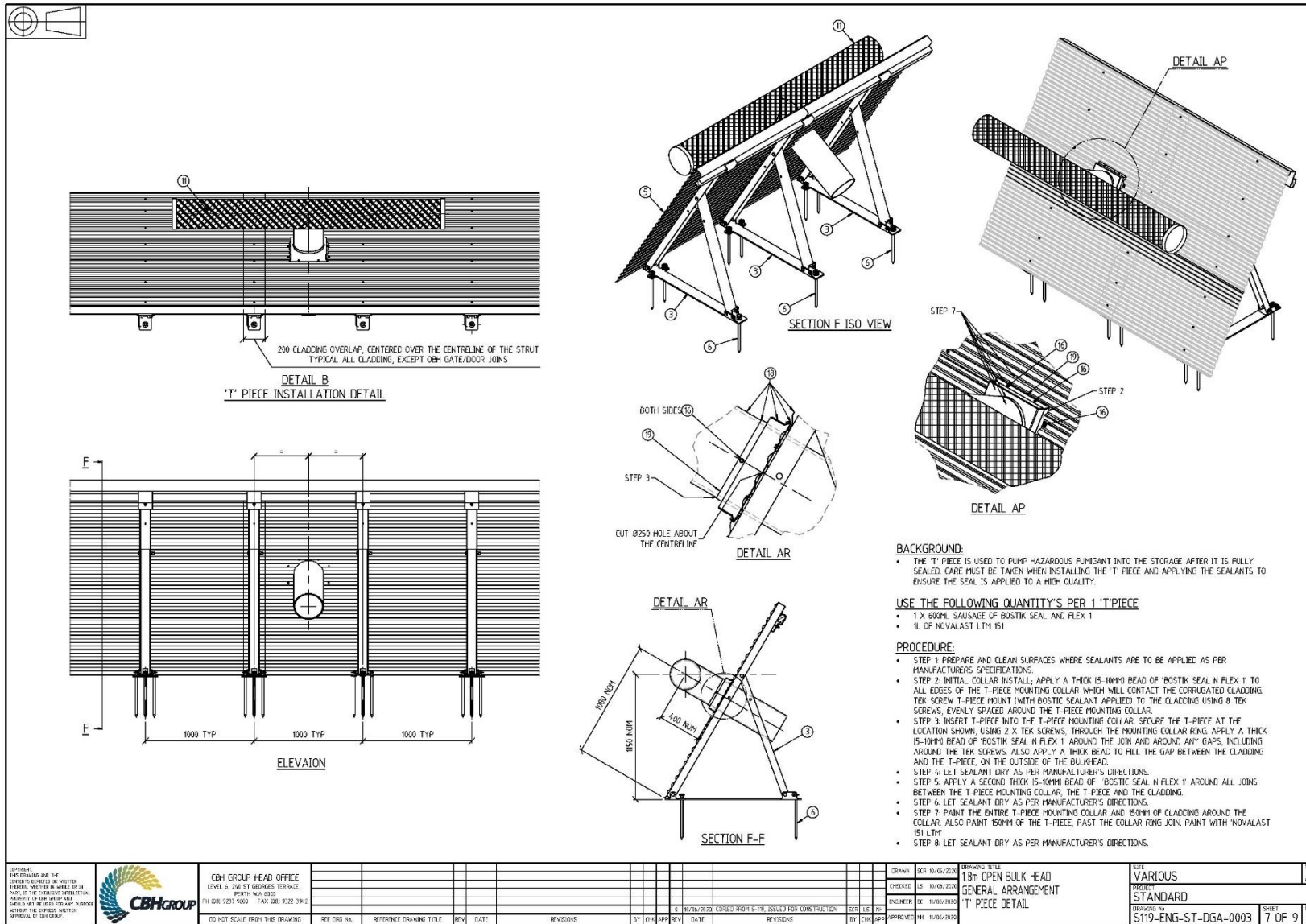

**DETAIL B**  
**'T' PIECE INSTALLATION DETAIL**

200 CLADDING OVERLAP, CENTERED OVER THE CENTRELINE OF THE STRUT  
TYPICAL ALL CLADDING, EXCEPT ODH GATE/DOOR JOINS

**ELEVATION**

1000 TYP

**SECTION F ISO VIEW**

**DETAIL AR**

BOTH SIDES

STEP 3

CUT Ø250 HOLE ABOUT THE CENTRELINE

**DETAIL AP**

STEP 7

STEP 2

**DETAIL AP**

**SECTION F-F**

1500 NOM

1500 NOM

400 NOM

**BACKGROUND:**

- THE 'T' PIECE IS USED TO PUMP HAZARDOUS FLUID INTO THE STORAGE AFTER IT IS FULLY SEALED. CARE MUST BE TAKEN WHEN INSTALLING THE 'T' PIECE AND APPLYING THE SEALANTS TO ENSURE THE SEAL IS APPLIED TO A HIGH QUALITY.

**USE THE FOLLOWING QUANTITIES PER 1 'T'PIECE**

- 1 X 600M SAUSAGE OF BOSTIK SEAL AND FLEX 1
- 1L OF NOVALAST LTM IS1

**PROCEDURE:**

- STEP 1: PREPARE AND CLEAN SURFACES WHERE SEALANTS ARE TO BE APPLIED AS PER MANUFACTURERS SPECIFICATIONS.
- STEP 2: INITIAL COLLAR INSTALL: APPLY A THICK 15-10MM BEAD OF BOSTIK SEAL N FLEX 1 TO ALL EDGES OF THE 'T' PIECE MOUNTING COLLAR WHICH WILL CONTACT THE CORRUGATED CLADDING. TEK SCREW 'T' PIECE MOUNT WITH BOSTIK SEALANT APPLIED TO THE CLADDING USING 8 TEK SCREWS, EVENLY SPACED AROUND THE 'T' PIECE MOUNTING COLLAR.
- STEP 3: INSERT 'T' PIECE INTO THE 'T' PIECE MOUNTING COLLAR. SECURE THE 'T' PIECE AT THE LOCATION SHOWN, USING 2 X TEK SCREWS THROUGH THE MOUNTING COLLAR RING. APPLY A THICK 15-10MM BEAD OF BOSTIK SEAL N FLEX 1 AROUND THE JOINT AND AROUND ANY GAFFS, INCLUDING AROUND THE TEK SCREWS. ALSO APPLY A THICK BEAD TO FILL THE GAP BETWEEN THE CLADDING AND THE 'T' PIECE, ON THE OUTSIDE OF THE BULKHEAD.
- STEP 4: LET SEALANT DRY AS PER MANUFACTURER'S DIRECTIONS.
- STEP 5: APPLY A SECOND THICK 15-10MM BEAD OF BOSTIK SEAL N FLEX 1 AROUND ALL JOINTS BETWEEN THE 'T' PIECE MOUNTING COLLAR, THE 'T' PIECE AND THE CLADDING.
- STEP 6: LET SEALANT DRY AS PER MANUFACTURER'S DIRECTIONS.
- STEP 7: PAINT THE ENTIRE 'T' PIECE MOUNTING COLLAR AND 150MM OF CLADDING AROUND THE COLLAR. ALSO PAINT 150MM OF THE 'T' PIECE, PAST THE COLLAR RING JOINT. PAINT WITH NOVALAST IS1 LTM.
- STEP 8: LET SEALANT DRY AS PER MANUFACTURER'S DIRECTIONS.

**CBH GROUP HEAD OFFICE**  
LEVEL 6, 250 ST GEORGES TERRACE,  
WESTERN HILLS CROSSING  
PH: 08 9237 5600 FAX: 08 9232 3942

**CBH GROUP**

REV	DATE	BY	CHK	APP	REV	DATE	BY	CHK	APP

DATE	02/06/2020	DRAWING TITLE	18m OPEN BULK HEAD
CHECKED	03/09/2020	GENERAL ARRANGEMENT	
ENGINEER	11/06/2020	'T' PIECE DETAIL	
APPROVED	11/06/2020		

SCALE: VARIOUS

PROJECT: STANDARD

DRAWING NO: S119-ENG-ST-DGA-0003

SHEET: 7 OF 9

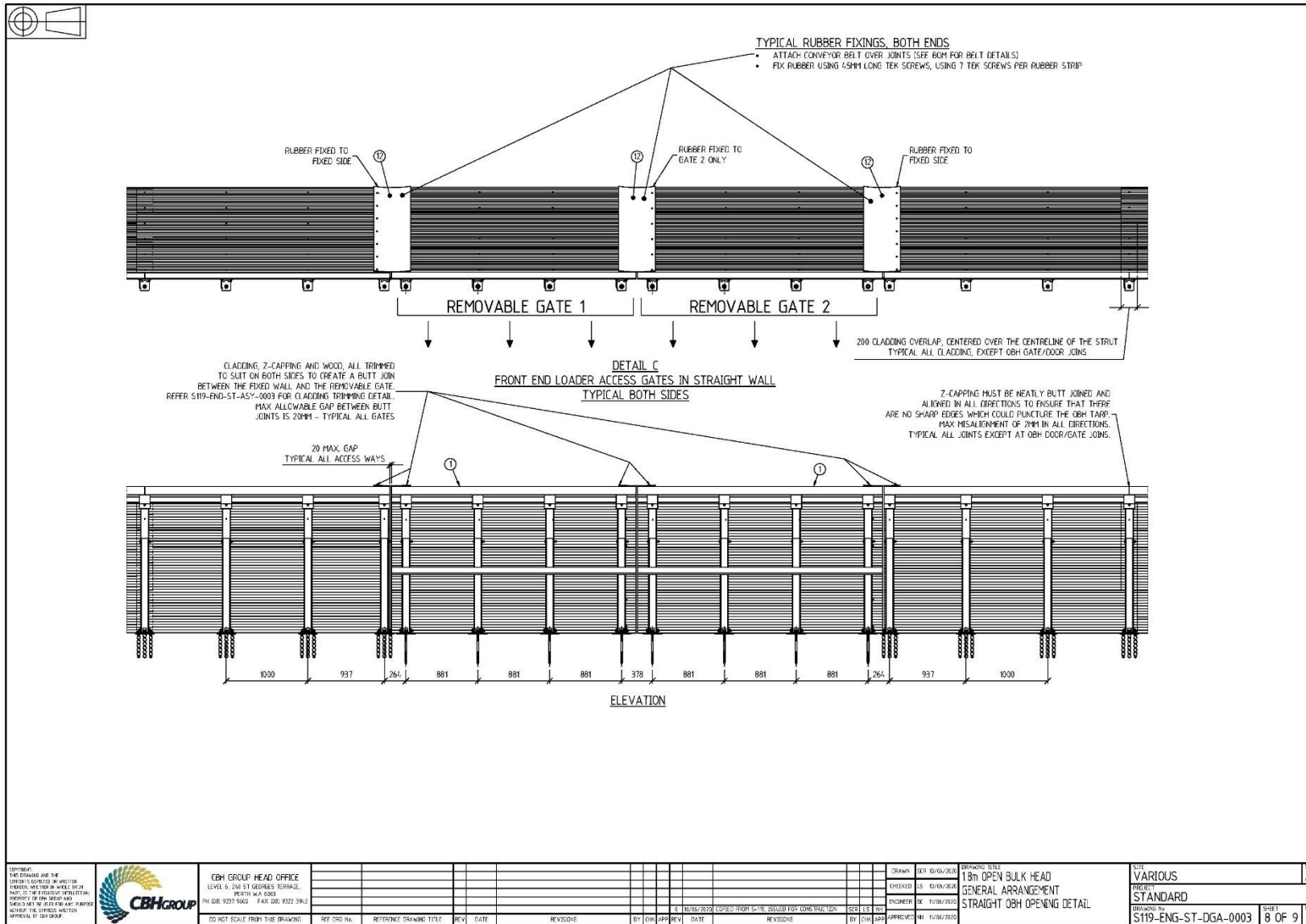

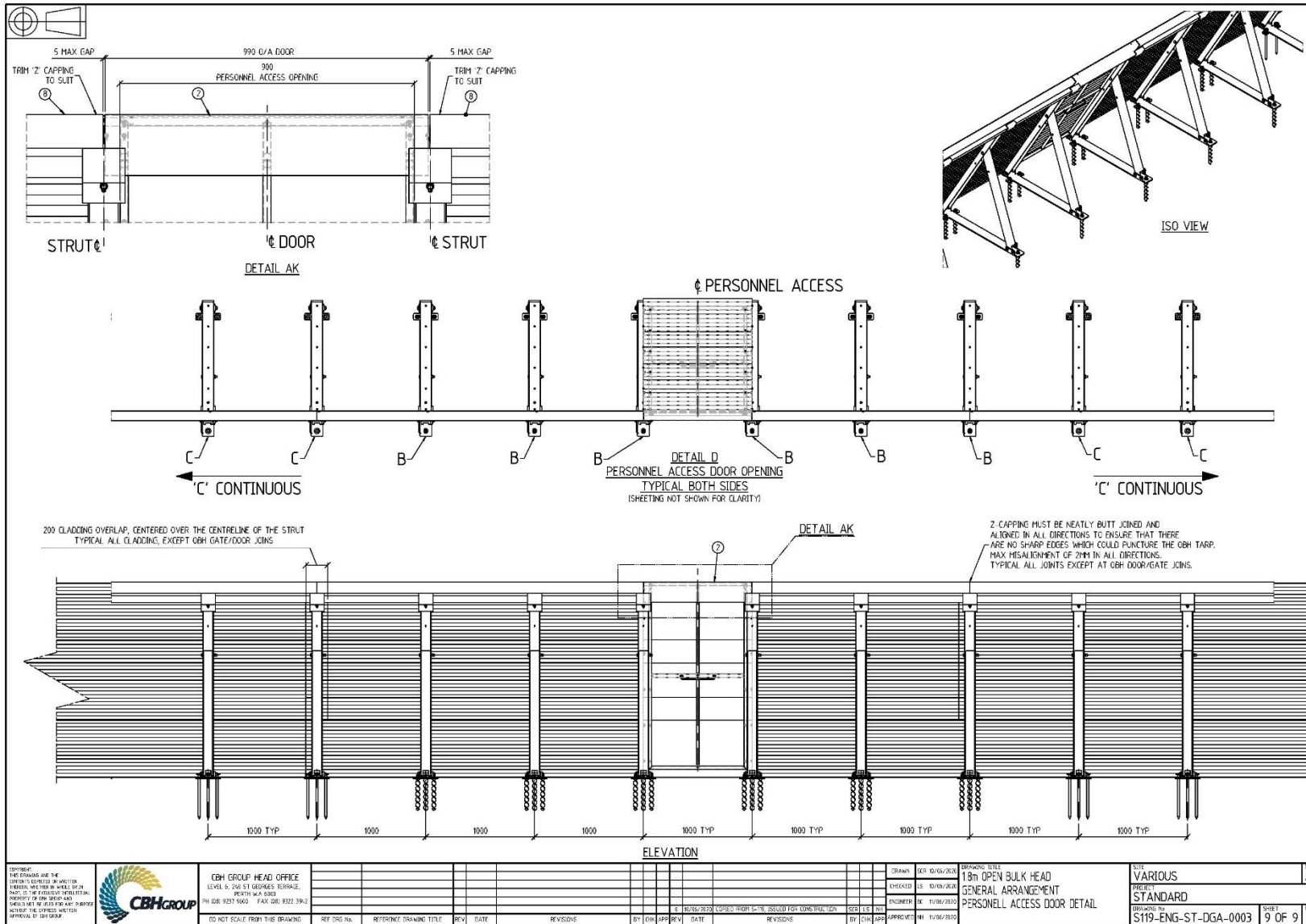



Project:	Meenaar 2022 Emergency Bulkhead Stormwater Management Plan
Client:	CBH
Author:	R. Needham
Date:	27 <sup>th</sup> July 2022
Shawmac Document #:	2207017-REP-001

CONSULTING CIVIL AND TRAFFIC ENGINEERS  
1 ST. FLOOR, 908 ALBANY HIGHWAY, EAST VICTORIA PARK WA 6101.  
PHONE|+61 8 9355 1300  
EMAIL|admin@shawmac.com.au



ISO 9001 QUALITY  
Certified System



Document Status:

Version	Prepared By	Reviewed By	Approved By	Date
A	R. Needham	J. Bridge	R. Needham	27/07/22

Disclaimer

Although all care has been taken in the preparation of this document, Shawmac Pty Ltd and all parties associated with the preparation of this document disclaim any responsibility for any errors or omissions. Shawmac Pty Ltd reserves the right to amend or change this document at any time. This document does not constitute an invitation, agreement or contract (or any part thereof) of any kind whatsoever. Liability is expressly disclaimed by Shawmac Pty Ltd for any loss or damage which may be sustained by any person acting on this document © Shawmac Pty. Ltd. 2016 ABN 51 828 614 001

File Reference: W:\haw-sw\NewData\Jobs Active 2022\CE - Roads and Drainage\CBH - Meenaar Emergency Bulkhead\_2207017\3. Documents\3.3 Design Report\SWMP\2207017-REP-001.docx



## Contents

1.	Introduction .....	4
1.1.	The Project .....	4
1.2.	Purpose .....	4
1.3.	History .....	5
2.	Pre-developed Situation .....	6
2.1.	General .....	6
2.2.	Site Characteristics .....	6
2.3.	Topography .....	6
2.4.	Geotechnical .....	7
2.5.	Environmental .....	8
2.6.	Catchment and Surface Water Flows .....	8
3.	Stormwater Management Strategy .....	10
3.1.	Strategy Overview .....	10
3.2.	Design Criteria and Modelling Assumptions .....	10
3.3.	Stormwater Quantity .....	12
	Appendix A – CBH Concept Plan .....	13

## Figures

Figure 1:	Meenaar Site .....	4
Figure 2:	Pre-developed Site Characteristics .....	6
Figure 3:	Existing Topography .....	7
Figure 4:	Catchment Areas and Surface Water Flows .....	9



---

**Tables**

Table 1: Existing Catchment Flow Rates..... 9

Table 2: Basin Details..... 12





## 1. Introduction

### 1.1. The Project

CBH are in the process of planning for an emergency specification open Bulkhead (OBH) expansion to their existing Meenaar site to be delivered before the 2022 harvest. The Meenaar site is located within the Avon Industrial Park, approximately 20km east of the existing CBH Avon site, along Great Eastern Highway (GEH).

The Meenaar site has been operating in a temporary manner for one year, after CBH constructed 6x emergency bulkheads on the site ahead of the 2021 harvest.

The 2022 emergency OBH expansion involves the construction of three new bulkheads (TBH 07,08 and 09) to provide 1231,140t of storage. Refer to **Appendix A – CBH Concept Plan** which shows the proposed bulkhead areas.

**Figure 1** shows the general location of the Meenaar site.



Figure 1: Meenaar Site

### 1.2. Purpose

The purpose of this report is to outline and quantify the proposed stormwater management measures to be



adopted for the emergency bulkhead construction. This SWMP has been prepared ahead of detailed designs for the bulkhead construction and will be utilised to guide the future design work.

### 1.3. History

Shawmac previously prepared a Stormwater Management Plan to support the 2021 emergency expansion. Refer to document 2106010-REP-005. The 2021 SWMP identified the stormwater management measures to be adopted for the previous emergency bulkhead construction. In general, these included:

- Maintaining the two existing discharge points from the site.
- Installation of 2x new drainage basins just upstream of each site discharge point to compensate post-development outflow rates to pre-developed levels for up to the 5-year ARI event.
- The basins were designed to be free-draining (i.e. with an outlet at base level) so that they would empty between design events.
- Design of internal open drains and culverts in accordance to CBH's emergency bulkhead design criteria for up to the 5-year ARI event.

Although the 2021 SWMP proposed that the basins were to be free draining, they were not constructed this way. The reason behind this is not known, but may be due to a common Shire requirement to retain stormwater drainage on site.



## 2. Pre-developed Situation

### 2.1. General

For the purpose of this SWMP, the pre-developed descriptions will mainly reflect the situation prior to construction of the 2021 emergency bulkheads. Both the 2021 and 2022 emergency constructions seek to replicate the pre-developed situation as far as practical.

### 2.2. Site Characteristics

The pre-developed site was vacant and cleared of almost all significant vegetation. The site is bound by Leeming Road to the south, railway and Great Eastern Highway to the north, industrial development to the east and farmland to the west. The site is generally featureless except for a sand quarry located in the central northern part of the site and a number of rock outcrops throughout the site.

Error! Reference source not found. shows an aerial image of the pre-developed site.



Figure 2: Pre-developed Site Characteristics

### 2.3. Topography

Figure 3 shows the topography (2m contours) of the site and its immediate surrounds, as well as the 2021



emergency bulkhead construction. The site is undulating, and ranges in height from approximately 226m AHD along the eastern boundary to 251m AHD in the central northern area. A ridge in the northern part of the site and saddle in the southern portion results in the land falling to the north, east and southwest. The typical gradients are in the order of 1.5% to 7%.



Figure 3: Existing Topography

#### 2.4. Geotechnical

Galt Geotechnics undertook a geotechnical investigation of the site in July 2021 which involved excavation of 6 test pits at depths ranging from 1.0m to 2.9m. Galt described the subsurface conditions generally as follows:

- Northern portion (TBH05/06):
  - Thin layer of topsoil over variable thickness gravelly soil (gravelly sand/sandy gravel) and residual to extremely weathered rock (sandy clay to clay) to the maximum investigated depth of 2.3m.
- Balance of site:
  - Thin layer of topsoil over residual to extremely weathered rock. The weathered rock varies significantly between Sandy Clay/Clay, Clayey Sand and gravelly soils.



A previous geotechnical investigation was undertaken by GHD in September 2010 for the entire Avon Industrial Park. GHD described the soils the of the site as generally consisting of a layer of topsoil over residual and extremely weathered granitic gneiss soil, overlying granite gneiss bedrock. Localised yellow sand and gravelly sand/sandy gravel were encountered in the proximity of the existing quarry, with the thickness of sandy material ranging from 0.9m to 2.7m depths. Several rock outcrops were identified throughout the site.

Permeability tests were undertaken by GHD which indicated the permeability of the site soils range from 0.08m/day to 0.1 m/day. GHD advised that stormwater disposal through infiltration is not recommended.

## 2.5. Environmental

The site is almost completely cleared of natural vegetation and there is little environmental value within the site. The northern and eastern portion of the site fall towards Grass Valley Brook on the northern side of Great Eastern Highway. Grass Valley Brook combines with Mortlock River and then Avon River at Northam. The south western portion of the site falls towards an unnamed creek which traverses through farm land and connects to Mortlock River approximately 5km south east of the site.

## 2.6. Catchment and Surface Water Flows

Based on the location of the proposed OBH's and the existing topography, the site can be divided into two catchments. Catchment 'A' is located over the western portion of the site and discharges towards a culvert underneath Leeming Road which outfalls into the creek line running south to Mortlock River. Part of the adjacent farm to the west of the CBH site also contributes to this outlet. Catchment 'B' is located over the eastern portion of the site and discharges towards a creek line which flows into culverts under the railway, Great Eastern Highway and then Grass Valley Brook.

The proposed TBH07 is situated on the boundary between Catchment 'A', 'B' and the external catchment which falls north towards the railway line and Great Eastern Highway. CBH's design standards (open drains) will result in all runoff from TBH07 being directed to Catchment 'A' or 'B'. Given that the area of TBH07 within the external catchment is negligible in comparison to the overall catchment, the external catchment will be excluded from further assessment.



Figure 4: Catchment Areas and Surface Water Flows

The existing catchments were assessed using ARR's (2001) Index Flood Method. **Table 1** below shows the estimated pre-existing flow rates for various Average Recurrence Intervals.

Table 1: Existing Catchment Flow Rates

Catchment	2 year	5 year	10 year	20 year	50 year
A	0.30m <sup>3</sup> /s	0.62m <sup>3</sup> /s	1.14m <sup>3</sup> /s	2.01m <sup>3</sup> /s	3.79m <sup>3</sup> /s
B	0.18m <sup>3</sup> /s	0.38m <sup>3</sup> /s	0.69m <sup>3</sup> /s	1.22m <sup>3</sup> /s	2.30m <sup>3</sup> /s



### 3. Stormwater Management Strategy

#### 3.1. Strategy Overview

The proposed stormwater management strategy is identical to that adopted for the 2021 emergency bulkhead construction, including construction of the basins to not be free draining (i.e. without a low level culvert outlet). Note that the basin design parameters described in the 2021 SWMP reflect a free draining scenario. For this 2022 SWMP, the basin design parameters are much more onerous to reflect the increase catchment area for the site expansion as well as the removal of the low level culvert outlets.

Similar to the 2021 construction, the proposed overall drainage strategy primarily involves the retention of the two existing discharge points. Basin's 'A' and 'B' will be located just upstream of these locations and will be sized to CBH's design criteria to retain the entirety of the critical 5-year event. For events greater than this, the basins will overtop towards the existing discharge points. Typically, for Meenaar, the critical 5-year event (24 hours) of 54.8mm represents 78% of the average rainfall received in the month of July (70.1 mm).

The proposed OBH's and other infrastructure areas are almost entirely located within either Catchment 'A' or 'B' and accordingly, the earthworks designs will seek to maintain the existing catchment boundaries and overall areas as far as practical, and to direct runoff from the entire infrastructure area to one of the basins.

There is a small area of the northern part of the bulkheads (TBH07) that sits just outside the Catchment 'A' or 'B' boundary. This is a portion of land on the northern side of the natural ridge which falls to the north. This area will be captured in the open drains and directed to the two drainage basins to prevent uncontrolled runoff towards the north. This will require the basins to be slightly larger by proportion due to the change in catchment area.

As the site has poor infiltration characteristics and no low level outfall, the basins will start to fill after the first rains and drain very slowly, if at all. It is possible that the basin will fill and leave insufficient capacity for further rainfall events, then overtop towards the existing flow paths. There is risk of scour and transport of sediments occurring to the downstream land should the basins overtop. Provision will be made for this, through the construction of a controlled weir outfall from the basin and installation of loose rock to reduce velocities and promote sheet flow, but it should be noted that these measures are not 100% effective and ongoing monitoring and some repair work are likely to be required.

It is understood that after service life, CBH either decommission the basin and emergency bulkheads (and restore the site to its original conditions) or implement a permanent drainage solution in line with the planned permanent expansion of Meenaar site.

#### 3.2. Design Criteria and Modelling Assumptions

Based on the adopted strategy and CBH's emergency bulkhead design specifications, the key stormwater



management design criteria are summarised as follows:

- The existing internal and external catchments should retain their current flow paths through to the existing site discharge points as far as practical.
- The basin is to be sized for the critical 5-year event, with no outfall and a 300mm freeboard.
- The basin, open drains and culverts are to be sized for the 5-year ARI event in accordance with CBH requirements.
- A nominal 100mm/day infiltration rate has been assumed to reflect some seepage and evaporation.
- The basins should have provision for a controlled weir overflow and scour protection measures.
- Open drains are to be set at a minimum 300mm deep below the bottom of pavement, or 600mm below surface where no pavement is to be installed.
- Culvert headwater heights are to be limited to a maximum 300mm below shoulder surface level.
- Culverts may have a minimum 400mm cover.
- Minimum drain fall of 0.3% in accordance with CBH requirements.
- No scour protection (likely problem areas (>2m/s velocity to be highlighted), except for basin outlets.

A preliminary XPSTORM model has been built for the proposed works. The following key assumptions were utilised:

- Infiltration losses were assumed as 15mm from pervious areas. Nil losses were assumed for impervious areas.
- Rainfall intensities and temporal patterns are consistent with ARR 2019.
- Mannings 'n' value of 0.03 was assumed for open drains, to allow lower construction tolerances and some vegetation growth.
- The temporary OBH's are assumed to be impervious, and runoff occurs in one direction, consistent with the earthworks design. Note that when the tarping is installed runoff from half the OBH will fall in the opposite direction. The open drains have been checked for capacity under these conditions.





### 3.3. Stormwater Quantity

**Table 2** and Error! Reference source not found. provide summaries of the modelling outcomes of the basins and culverts, respectively. All results reflect the 5-year event.

**Table 2: Basin Details**

Item	Basin A	Basin B
Base Level (m AHD)	228.70	229.66
Base Area (m <sup>2</sup> )	5,000	8,800
Top Level (m AHD)	230.50	231.16
Top Area (m <sup>2</sup> )	6,000	9,800
Max Volume (m <sup>3</sup> )	9,900	13,500
TWL (m AHD)	230.19	230.81
Freeboard (m)	0.31	0.35
Max Stored Volume	8,083	10,695
Max Outflow Rate (m <sup>3</sup> /s)	-	-

Culvert and open drains have not been modelled in detail at this stage. These designs will be finalised in conjunction with the detailed earthworks designs, consistent with the design criteria outlined in the previous section of this report.



---

Appendix A – CBH Concept Plan

---

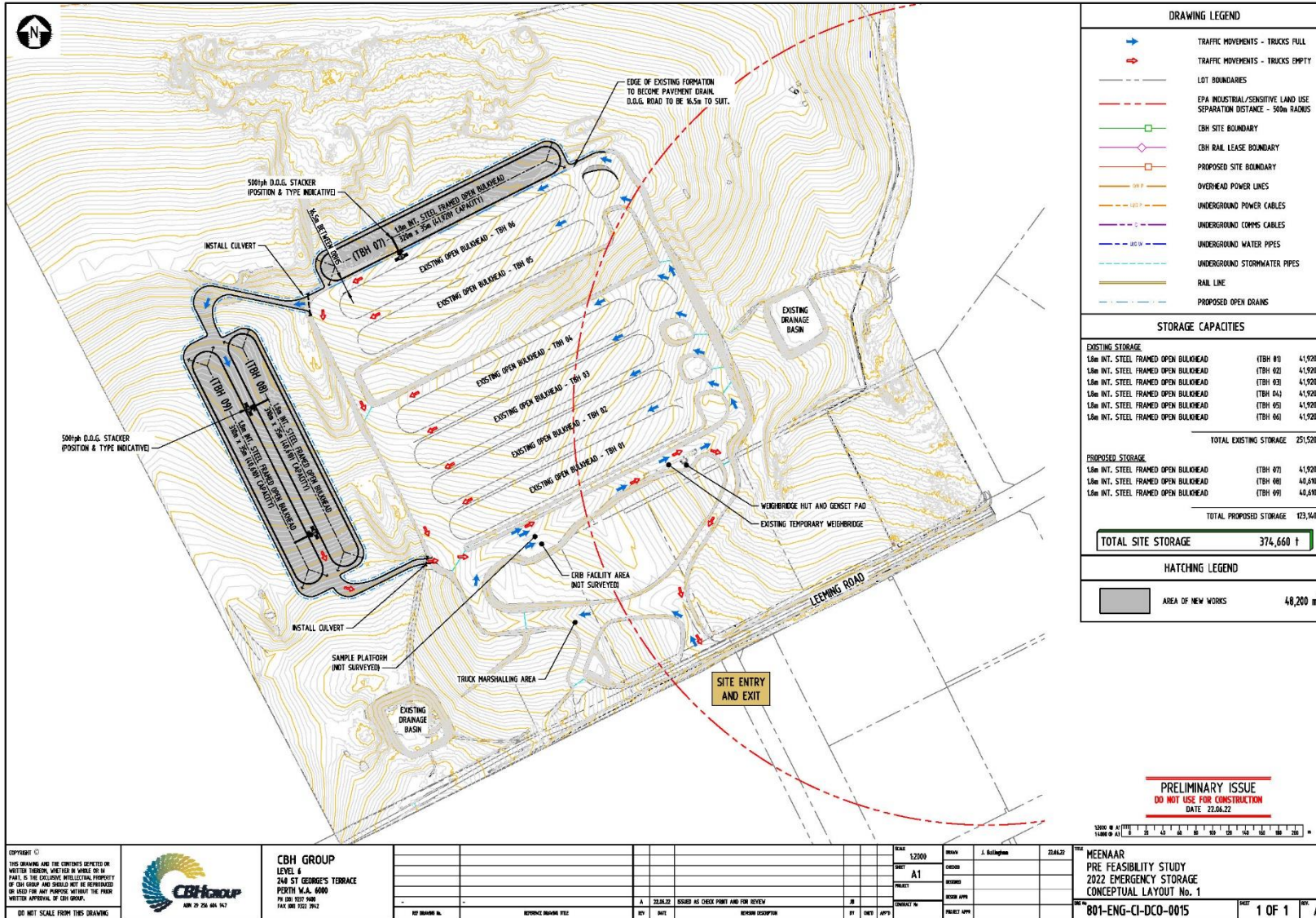



Project:	Meenaar Emergency OBH's
Client:	CBH
Author:	J. Bridge
Date:	27 <sup>th</sup> July 2022
Shawmac Document #:	2207017-TIS-001

CONSULTING CIVIL AND TRAFFIC ENGINEERS  
1 ST. FLOOR, 308 ALBANY HIGHWAY, EAST VICTORIA PARK WA 6101.  
PHONE +61 8 9355 1300  
EMAIL [admin@shawmac.com.au](mailto:admin@shawmac.com.au)



ISO 9001 QUALITY  
Certified System



Document Status: Client Review

Version	Prepared By	Reviewed By	Approved By	Date
A	J. Bridge	R. Needham	J. Bridge	27.07.22

Disclaimer

Although all care has been taken in the preparation of this document, Shawmac Pty Ltd and all parties associated with the preparation of this document disclaim any responsibility for any errors or omissions. Shawmac Pty Ltd reserves the right to amend or change this document at any time. This document does not constitute an invitation, agreement or contract (or any part thereof) of any kind whatsoever. Liability is expressly disclaimed by Shawmac Pty Ltd for any loss or damage which may be sustained by any person acting on this document © Shawmac Pty. Ltd. 2016 ABN 51 828 614 001

File Reference: Y:\Jobs Active 2022\ICE - Roads and Drainage\CBH - Meenar Emergency Bulkhead\_2207017\3. Documents\3.6 TIS\2207017-TIS-001 RevA.docx



## Contents

1.	Introduction .....	1
1.1.	Background.....	1
2.	Existing Situation.....	2
2.1.	Road Network.....	2
2.2.	Speed Limit.....	2
2.3.	Carriageway Width and Cross Section .....	3
2.4.	Traffic Volumes .....	4
2.5.	RAV Status .....	6
2.6.	Crash History .....	8
2.7.	Changes to Surrounding Transport Networks.....	8
3.	Traffic Generation .....	9
3.1.	Development Details .....	9
3.2.	Haulage Vehicle.....	9
3.3.	Operating Hours and Reveal Period.....	9
3.4.	5-year Average Traffic Data.....	9
3.5.	Predicted Traffic without Emergency OBH.....	10
3.6.	Predicted Traffic with Emergency OBH.....	10
3.7.	Haulage Route.....	11
3.8.	Peak Period Assessment.....	11
4.	Traffic Impact Assessment.....	13
4.1.	Assessment Years.....	13
4.2.	Impact on Roads.....	13
4.2.1.	Road Minimum Widths.....	13
4.3.	Road Safety.....	13
4.4.	Safe Intersection Sight Distance – Site Exit.....	13
4.5.	Entering Sight Distance – Site Exit.....	16



---

5. Conclusions .....	17
Appendix A – CBH Concept Plan .....	18
Appendix B – Traffic Count Data .....	19



## Figures

Figure 1: Site Location.....	1
Figure 2: Road Hierarchy Layout.....	2
Figure 3: MRWA Speed Limit of Surrounding Road Network.....	3
Figure 4: Traffic Count Location.....	5
Figure 5: RAV Status - Tandem Drive Network.....	7
Figure 6: RAV Status - Tri Drive Network.....	7
Figure 7: MRWA Crash report mapping.....	8
Figure 8: Typical Tandem Drive RAV7.....	9
Figure 9: Peak Daily / Hour Volumes (CBH Only).....	12
Figure 10: Looking East Along Leeming Road from Site Access.....	14
Figure 11: Looking West Along Leeming Road from Site Access.....	15
Figure 12: Site Access SISD.....	15

## Tables

Table 1: Road Configuration.....	3
Table 2: Daily Traffic Volumes (Monday to Friday).....	4
Table 3: Peak Hour Traffic Volumes.....	4
Table 4: Harvest Truck Movement Comparison.....	11
Table 5: Rural Road Minimum Width.....	13
Table 6: SISD at Site Access.....	16
Table 7: RAV Vehicle Entering Sight Distance.....	16





## 1. Introduction

### 1.1. Background

CBH are proposing to construct emergency open bulkheads (TBH) at their existing Meenaar site in preparation for the 2022 harvest. It is proposed to construct three new emergency TBH's (TBH 07,08,09) with 123,140t capacity which will utilise the existing site access/exit and marshal/sample/weigh facilities.

Shawmac have been commissioned to prepare a Traffic Impact Statement assessing the impacts of the proposed emergency OBH storage on the surrounding road network.

**Figure 1** shows the existing site and location of the proposed emergency TBH's. Refer to **Appendix A – CBH Concept Plan** for full details of the proposal.

The emergency TBH's are anticipated to be in place for one year only.

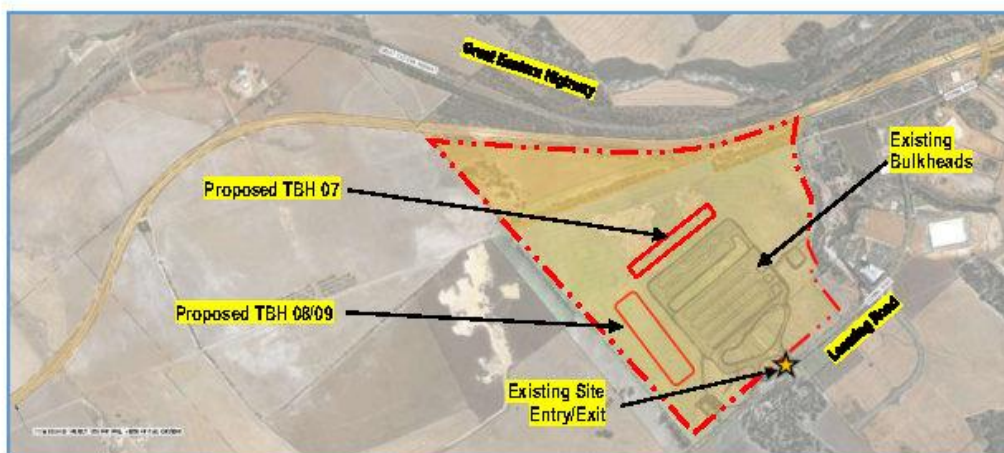

Figure 1: Site Location



## 2. Existing Situation

### 2.1. Road Network

The layout and hierarchy of the existing road network according to the Main Roads Western Australia (MRWA) Road Information Mapping System is shown in **Figure 2**.

As shown, Leeming Road is classified as an Access Road.

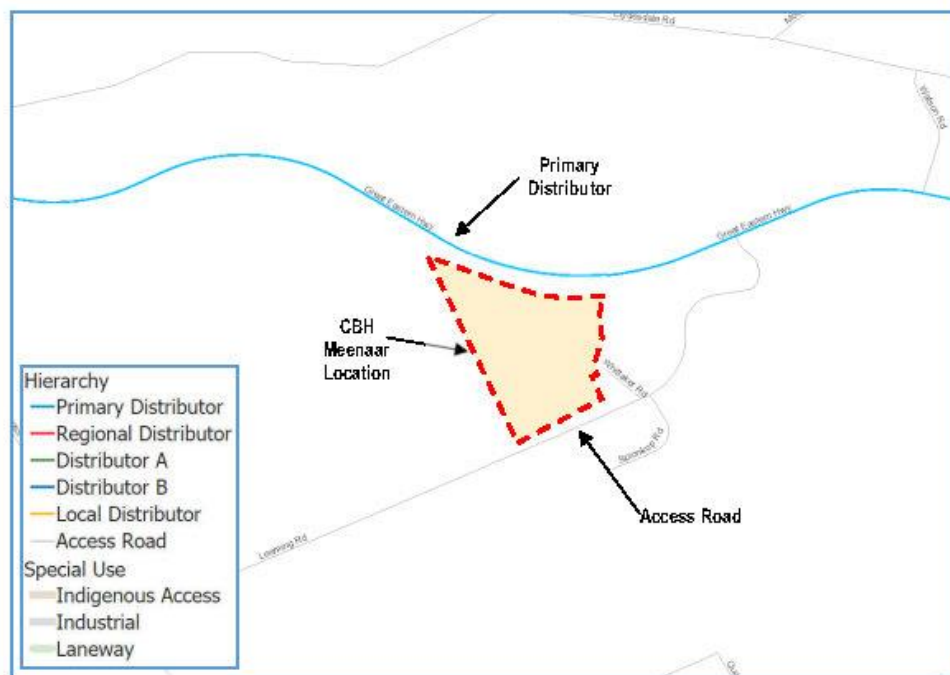

Figure 2: Road Hierarchy Layout

### 2.2. Speed Limit

As per MRWA's Road Information Mapping System, Leeming Road has a posted speed limit of 50 km/h. **Figure 3** shows the speed zoning of the surrounding road network.

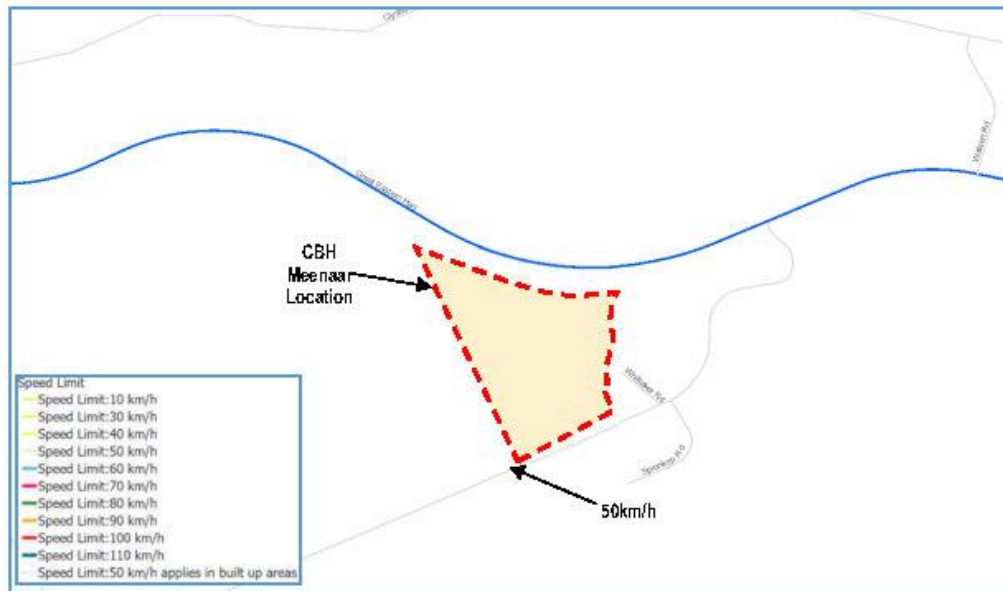

Figure 3: MRWA Speed Limit of Surrounding Road Network

### 2.3. Carriageway Width and Cross Section

The carriageway and configuration of the relevant adjacent roads are summarised in **Table 1**.

Table 1: Road Configuration

Road and Location	Road Type	Cross Section	Carriageway Width (Approx.)	Sealed Pavement Width (Approx.)
Leeming Road	Access Road	Two-lane single carriageway	9.5-10m	8.2-8.5m

The above measurements were taken from survey previously provided by CBH.



## 2.4. Traffic Volumes

The latest traffic volumes for Leeming Road were obtained from MRWA Traffic map as summarised in **Table 2** and **Table 3**.

As shown in **Figure 4**, the traffic count is located north of the CBH site and the pre-existing developed industrial area. In addition, the CBH site is at the end of the sealed section of Leeming Road where there is expected to be negligible public traffic as there is a closed gate restricting public and CBH access from the unsealed section of Leeming Road. Therefore, the traffic volumes along Leeming Road fronting the CBH site are expected to be much lower than the traffic count volumes. For conservatism, the traffic count volumes have been adopted for the existing traffic fronting the CBH site. In addition, it is assumed that the traffic count volumes did not include any CBH traffic.

Considering the conservative approach mentioned above for assessing existing traffic fronting the CBH site, an annual growth factor has not been applied to the 2020/21 volumes and are considered suitable for the purpose of the 2022/23 assessment.

Detailed traffic count data is attached in **Appendix A**.

**Table 2: Daily Traffic Volumes (Monday to Friday)**

Road	Location	Daily Volume	Data Source
Leeming Road (4211128)	South of Great Eastern Highway (SLK 4.4)	147	MRWA 20/21

**Table 3: Peak Hour Traffic Volumes**

Road / Direction	Location	AM Peak	PM Peak	HV%
Leeming Road NB	South of Great Eastern Highway	7	16	22%
Leeming Road SB	South of Great Eastern Highway	15	5	



Figure 4: Traffic Count Location



## 2.5. RAV Status

As per MRWA HVS network mapping tool:

- Leeming Road (East of Site access)
  - Categorised under the Tandem Drive RAV 7.3 and Tri Drive 1.3 network with the following conditions.
  - Maximum speed 70km/h.
  - All operators must carry current written approval from the road asset owner permitting use of the road.
- Leeming Road (West of Site access)
  - Categorised under the Tandem Drive RAV 3.1 and Tri Drive 1.1 network with the following conditions.
  - Maximum speed 40km/h.
  - All Operators must carry current written approval from the road asset owner permitting use of the road. No Operation on unsealed road segment when visibly wet, without road owner's approval.

**Figure 5** and **Figure 6** shows the Tandem Drive and Tri-Drive network along Leeming Road.

It is noted the RAV status along Leeming Road varies and the classification changes from Tandem Drive 7.3 to 3.1 and Tri Drive 1.3 to 1.1. The maximum trucks able to access Leeming Road are RAV 7 trucks up to the site access.

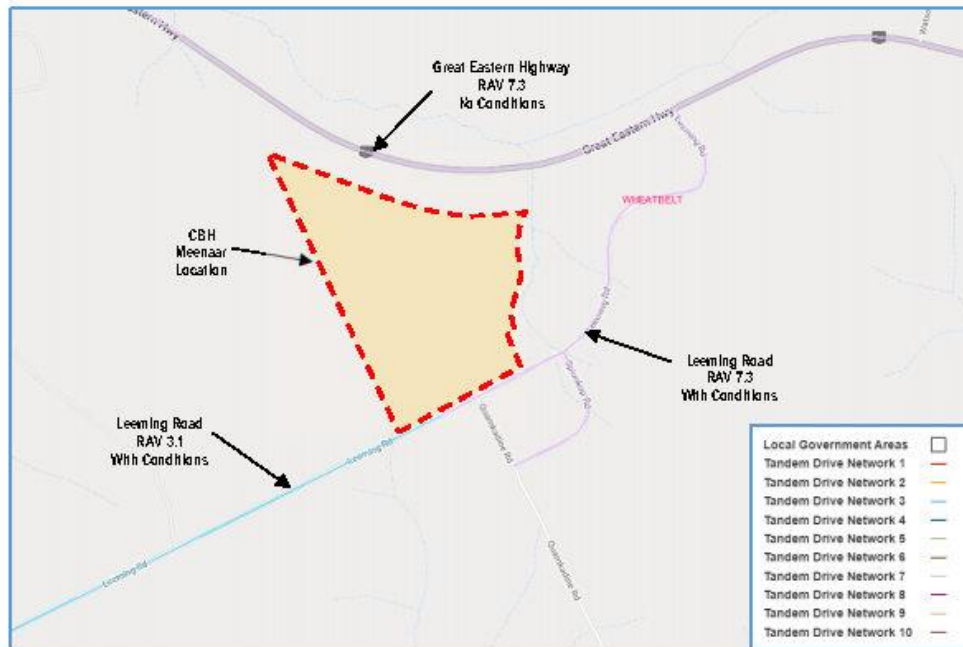

Figure 5: RAV Status - Tandem Drive Network



Figure 6: RAV Status - Tri Drive Network



## 2.6. Crash History

Crash data for the relevant roads in the vicinity of the site was sourced from MRWA Crash Analysis Reporting System (CARS) for the 5-year period ending 31/12/2021. This is shown in **Figure 7**.

Only one crash has been recorded along Leeming Road. The crash occurred on 13/01/2021 and involved a head on collision involving two vehicles. The severity is listed as "Property damage only".

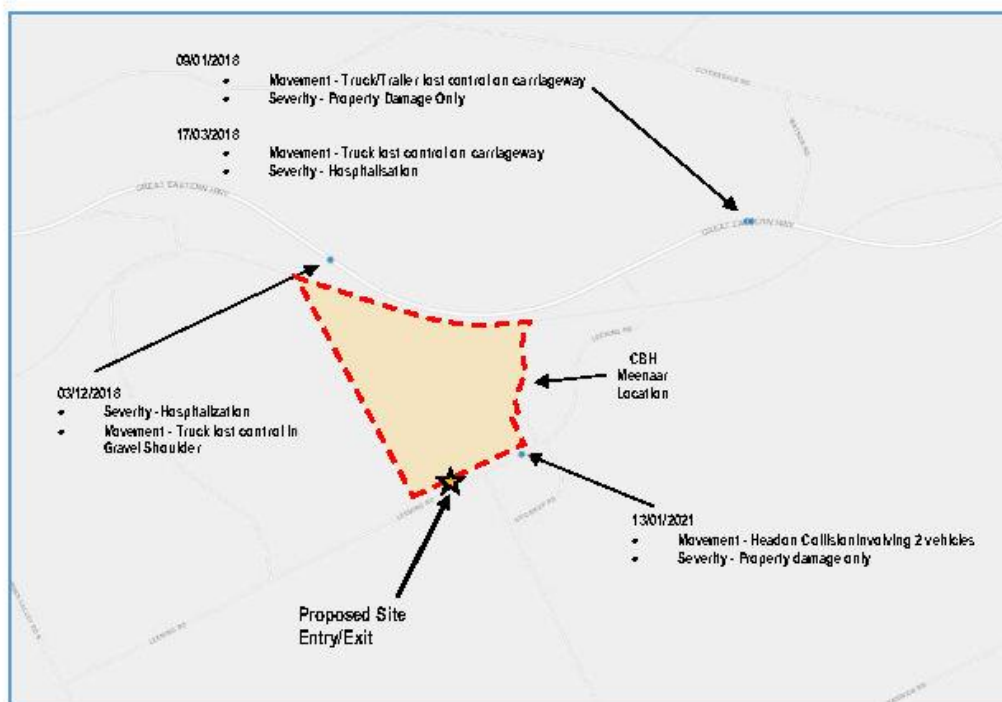

Figure 7: MRWA Crash report mapping

## 2.7. Changes to Surrounding Transport Networks

There are no known changes to the adjacent network that have the potential to affect the assessment. It is understood that in the medium term, it is likely that the intersection of Leeming Road and Great Eastern Highway will be upgraded, however this is outside the planned timeframe for the operation of the emergency bulkheads.





### 3. Traffic Generation

#### 3.1. Development Details

CBH propose to construct three new temporary TBH's to provide a total nameplate storage capacity of 123,140t. This will increase the total site storage capacity from 251,520t to 374,660t.

CBH have advised that the nameplate capacity is seldom able to be achieved. This is because of "loss by division/loss by commodity" where multiple grain types are required to be stored/tarped within the same TBH, resulting in less efficient storage. CBH have advised that maximum effective storage capacity for this site is generally around 94% of nameplate i.e., there is 6% lost due to loss by division/loss by commodity inefficiency. The effective existing storage capacity would therefore be 236,429t, increasing to 352,180t after construction of the emergency TBH.

However, CBH note that at present there is a large volume of "carry-over" grain at many sites including Meenaar. This is grain that, due to logistical constraints, has not been able to be removed from sites and exported prior to the upcoming harvest. This has left many sites, including Meenaar with a shortfall in capacity, and needing emergency storage to be built.

#### 3.2. Haulage Vehicle

It is proposed to use RAV7 trucks up to 36.5m long for the transport of grain. **Figure 8** shows a typical RAV7 vehicle. In addition, CBH also noted that while this site is rated for RAV7, deliveries would include haulage using RAV4 or even as low as RAV1 vehicles.



Figure 8: Typical Tandem Drive RAV7

#### 3.3. Operating Hours and Reveal Period

The campaign period for reveal of grains will start mid-October and last 2-3 months. It is noted that the amount of daily reveal varies depending on the supply.

CBH propose to operate the site 12 hours a day (6 AM to 6 PM) and Monday to Sunday with minor variations of start and finish times.

#### 3.4. 5-year Average Traffic Data

The Meenaar Site has only been in operation since last year's harvest (2021/22). Therefore, CBH have only last year's traffic data as follows:



- 2021/22 receivals – 109,597t
- Average truck payload – 50.1t
- Origin direction split – 12.77% north, 4.03% south, 43.95% east, 39.25% west.

The traffic / receival data indicates that the site is currently not being loaded to full capacity. However, given the significant harvest this year, CBH is anticipating an increase in received tonnes to the site (compared to last year). In addition, CBH note that at present there is a large volume of "carry-over" grain at many sites including Meenaar. This is grain that, due to logistical constraints, has not been able to be removed from sites and exported prior to the upcoming harvest. Therefore, although the entire Meenaar site provides a significant amount of storage, well over last year's receivals, it is understood that a large portion of this is not available for receivals.

### 3.5. Predicted Traffic without Emergency OBH

CBH are proposing to construct the emergency TBH's to increase site capacity so that more grain can be stored through the harvest and inefficient out loading movements within the harvest period are avoided.

During the harvest, once site capacity is reached, out loading movements may be required to restore capacity and allow grain to continue to be received from the nearby farms. This will involve shifting the grain from Meenaar to the next available site with storage capacity, with movement occurring towards the export port. This double-handling of grain is inefficient in terms of cost and adds additional traffic to the surrounding road network.

For comparative purposes it is useful to assess what would occur if the proposed emergency bulkheads are not constructed.

CBH expect that the 2022/23 harvest receivals will exceed the available capacity of the site by approximately the volume of the planned emergency storage. This would result in receivals of approximately 115,752t (123,140t x 94% efficiency). Based on the average truck payload of 50.1t, this would result in an additional 2,310 truck movements within the harvest period for out loading.

Note that for the purposes of this assessment a single 'movement' is defined as a round trip i.e. the site entry/delivery and site exit/return home comprise one movement.

If the emergency TBH is constructed, then the 2,310 truck movements still need to occur to move the grain for export, but this would occur outside the harvest period, when there are less trucks on the road network.

### 3.6. Predicted Traffic with Emergency OBH

Regardless of whether the emergency OBH's are built, the same higher than average delivery movements to the Meenaar site will occur during the harvest. The effect of constructing the emergency storage is that out loading movements during the busy harvest period are eliminated.

CBH expect that the 2022/2023 harvest will result in approximately 231,021t of grain being transported to the



Meenaar Site however, due to previous years of “carry-over” grain, it is understood that there is only 115,270t of storage available for receivals. Based on the average payload of 50.1t, **Table 4** provides an estimate of the 22/23 harvest period truck movements, with and without the proposed emergency OBH and with comparison to the current available storage.

**Table 4: Harvest Truck Movement Comparison**

	2021/22 Receivals	22/23 Without Emergency OBH	22/23 With Emergency OBH
Tonnes Received (t)	109,597	231,021	231,021
Truck Payload (t)	50.1	50.1	50.1
Total Harvest Receival Movements	2,188	4,611	4,611
Total Harvest Out Loading Movements		2,310	-
Total Harvest Movements	2,188	6,922	4,611

As shown, the movements for 2022/2023 regardless of the emergency TBH construction are expected to exceed the existing capacity and last year's truck movements, but the construction of the emergency TBH allows movements to be reduced in comparison to the scenario where the emergency TBH is not installed for the 2022/2023 harvest.

### 3.7. Haulage Route

All trucks will enter and leave the CBH site via the existing access/exit off Leeming Road. CBH anticipate that the site catchment will result in the following movement directional split:

- North – 12.77%
- South – 4.03%
- East – 43.95%
- West – 39.25%

Based on the road network and given the condition and low RAV status of Leeming Road (west of the proposed site access, which access is also closed off by a gate, it is assumed that 100% of movements will entire the site from a right turn off Leeming Road and all vehicles will access the site from Great Eastern Highway.

### 3.8. Peak Period Assessment

Although the harvest period is expected to occur over a period of approximately 2-3 months, it is known that there is a peak within this period. Specific data for Meenaar was not available to define this peak period, but data from other CBH sites indicate that generally 80-85% of grain is received within 28 days.

For the purposes of assessing the peak period impacts, the following assumptions have been made:



- 85% of total grain tonnes are received within, and evenly distributed over 28 days.
- Truck deliveries occur over a 12-hour period, and 10% of all daily volumes are received within a peak hour.

Based on these assumptions:

- 3,920 truck movements will occur during the 28-day peak.
- 140 movements will occur each day of the 28-day peak.
- 14 movements will occur during a peak hour.

Figure 9 shows the peak daily / hourly movement volumes based on the previously discussed traffic distribution. Note that figures have been rounded up to the nearest whole number.

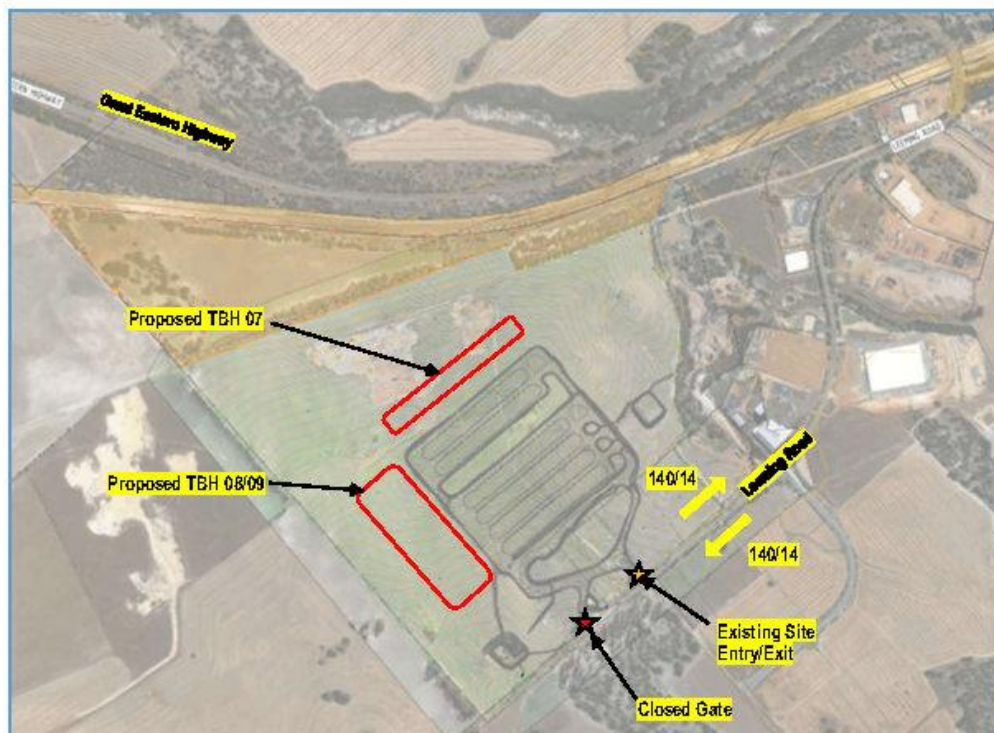

Figure 9: Peak Daily / Hour Volumes (CBH Only)



## 4. Traffic Impact Assessment

### 4.1. Assessment Years

The development is assessed based on current network condition (2022).

### 4.2. Impact on Roads

#### 4.2.1. Road Minimum Widths

The sealed widths of the surrounding roads were checked against the Rural Road Minimum Width in accordance with Appendix A of the MRWA RAV assessment guideline. The comparison is shown below in **Table 5**.

Table 5: Rural Road Minimum Width

Road	Location	Existing AADT	Proposed AADT (Peak)	Speed (RAV)	RAV Status	Required Minimum Seal / Carriageway	Existing Sealed / Carriageway Width
Leeming Road	South of Great Eastern Highway	147	287	50km/h	7.3	5.7m/7.7m	8.2-8.5m / 9.5-10m

As shown, the minimum widths all comply

### 4.3. Road Safety

The crash history of the adjacent road network (as previously outlined in **Section 2.6**) does not suggest any atypical safety issues in the existing road network. The additional traffic movements generated by the emergency bulkhead is not considered to increase the likelihood of crashes to unacceptable levels.

### 4.4. Safe Intersection Sight Distance – Site Exit

The Safe Intersection Sight Distance (SISD) is the minimum distance which should be provided on the major road at any intersection. SISD provides sufficient distance for a driver of a vehicle on the major road to observe a vehicle on a minor road approach moving into a collision situation (e.g. in the worst case, stalling across the traffic lanes) and to decelerate to a stop before reaching the collision point.

The SISD for the site exit along Leeming Road is assessed based on the following parameters:

- An observation time of 3 seconds as per Austroads Part 3;
- A reaction time of 2.5 seconds;
- Deceleration coefficients for the purpose of SISD calculations are 0.36 for light vehicles and 0.28 for heavy vehicles (Road Train Type 2 – RAV 7 equivalent);
- Driver eye height is 2.4m for trucks and 1.1m for cars; and



- Design speed for cars at 60km/h and trucks at 50km/h.

**Figure 10** and **Figure 11** show the available sight distance along Leeming Road from the site access. Note that although Leeming Road continues as an unsealed track extending west from the end of the cul-de-sac, there is a sight board and gate that prevent access. For illustrative purposes, the sight distance measurements extend past the sight board and gate along the track.

The available sight distances are measured at approximately 520m and 510m to the west and east, respectively, as shown in **Figure 12**.



Figure 10: Looking East Along Leeming Road from Site Access



Figure 11: Looking West Along Leeming Road from Site Access



Figure 12: Site Access SISD



Based on the sight distance parameters, **Table 6** shows a comparison between the required and available sight distances from the site access. As shown, the available sight distances are significantly greater than the minimum requirements.

**Table 6: SISD at Site Access**

Location	Vehicle Type	Design Speed (km/h) (EB / WB)	Coefficient of Deceleration	Decision Time (s)	Longitudinal Grade (EB / WB) <sup>a</sup>	Required SISD for EB / WB Traffic (m)	Available SISD (m)	
							EB	WB
Site Exit	Trucks	50 / 50	0.28	3+2.5	2%/3%	109 / 108	520	510
	Cars	60 / 60	0.36	3+2.5	2%/3%	129 / 128	520	510

<sup>a</sup>Positive for through traffic travelling uphill and negative for through traffic travelling downhill. Grades are estimated only.

#### 4.5. Entering Sight Distance – Site Exit

The Entering Sight Distance (ESD) is the minimum distance for driver of a RAV, entering a through road, having appropriate sight distance to see a sufficient gap in oncoming traffic that will allow a RAV, with greater length and lower acceleration capacity, to clear the intersection safely.

The ESD is assessed based on the following parameters:

- A reaction time of 4 seconds, and
- Deceleration coefficients of 0.29 (up to 90km/hr).

The Entering Sight Distance (ESD) for existing and proposed access locations has been assessed in accordance with RAV Route Assessment Guideline (updated May 2022). A comparison of available and required ESD for RAV vehicles are summarised in **Table 7**.

**Table 7: RAV Vehicle Entering Sight Distance**

Location	Design Speed (km/h) (EB / WB)	Coefficient of Deceleration	Reaction Time (s)	Longitudinal Grade (EB / WB) <sup>a</sup>	Required ESD for EB / South WB (m)	Available ESD (m)	
						EB	WB
Site Exit	50 / 50	0.29	4	2% / 3%	242 / 238	520	510

<sup>a</sup>Positive for through traffic travelling uphill and negative for through traffic travelling downhill. Grades are estimated only.

As shown, the ESD are sufficient to achieve minimum requirements in accordance with the MRWA RAV Assessment Guideline.





---

## 5. Conclusions

This Traffic Impact Statement has been prepared for the proposed Emergency TBH to be installed at CBH's existing Meenaar site. The TIS concluded:

- The estimated traffic generation can be accommodated within the capacity of the adjacent road network.
- The additional traffic generated by the site is not considered to increase the likelihood of crashes to unacceptable levels.
- The seal and carriageway widths of the surrounding road network generally meet the relevant RAV network requirements.
- There is sufficient sight distance at the existing site exit.

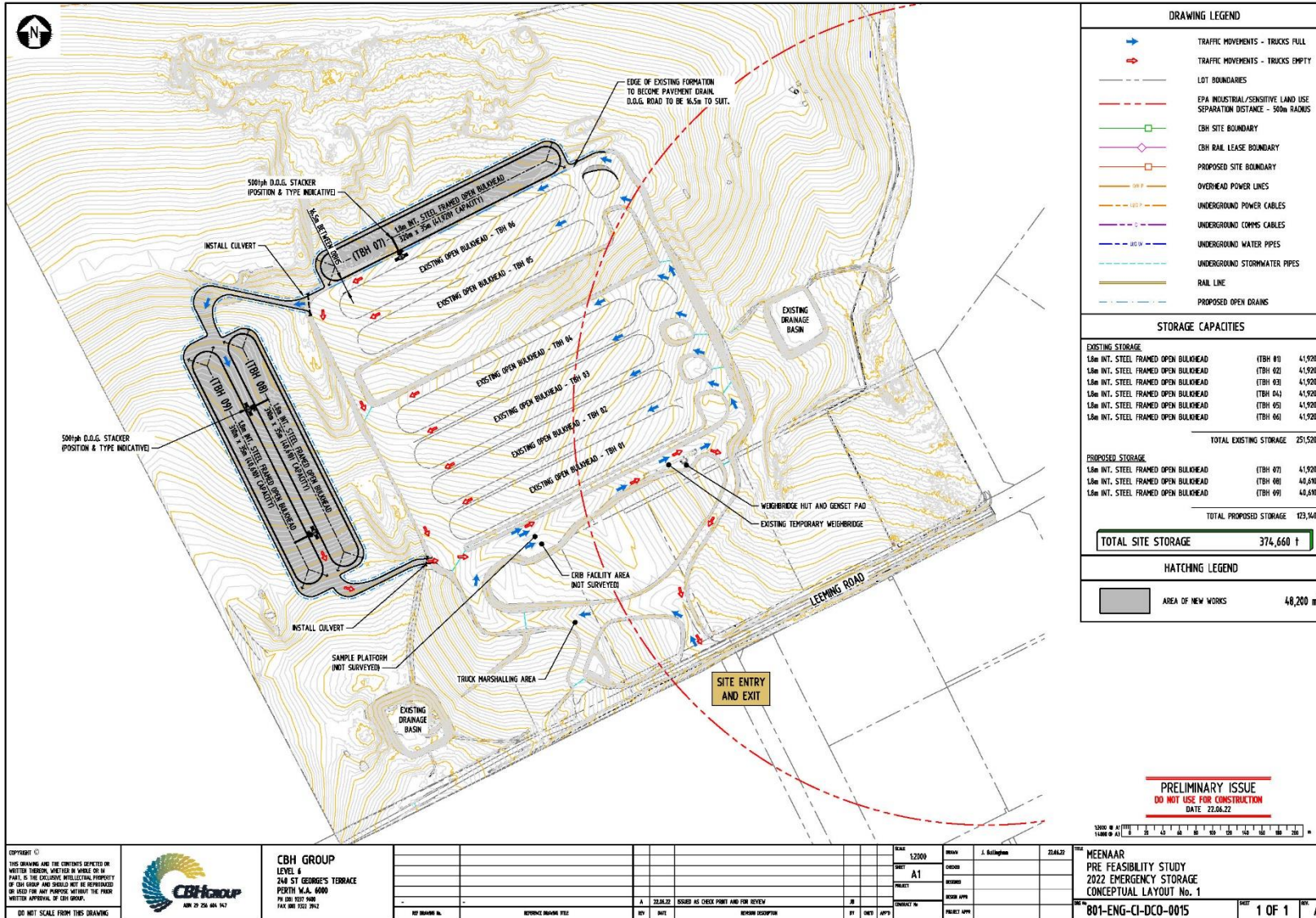



---

**Appendix B – Traffic Count Data**

---



SITE 53258

## Hourly Volume

Leeming Rd (4211128)

2020/21  
 Monday to Friday

South of Great Eastern Hwy (SLK 4.40)

	All Vehicles				Heavy Vehicles				
	NB	SB	Both	%	NB	SB	Both	%	
00:00	0	0	0	0.0	0	0	0	0.0	
01:00	0	0	0	0.0	0	0	0	0.0	
02:00	0	0	0	0.0	0	0	0	0.0	
03:00	0	0	0	0.0	0	0	0	0.0	
04:00	0	1	1	0.0	0	0	0	0.0	
05:00	0	12	12	0.0	0	0	0	0.0	
06:00	3	12	15	20.0	2	1	3	20.0	
07:00	6	8	14	28.6	3	1	4	28.6	
08:00	5	8	13	46.2	3	3	6	46.2	
09:00	2	4	6	16.7	0	1	1	16.7	
10:00	3	5	8	25.0	1	1	2	25.0	
11:00	3	4	7	14.3	0	1	1	14.3	
12:00	5	4	9	22.2	1	1	2	22.2	
13:00	5	4	9	44.4	2	2	4	44.4	
14:00	4	3	7	42.9	1	2	3	42.9	
15:00	11	3	14	7.1	1	0	1	7.1	
16:00	15	1	16	12.5	2	0	2	12.5	
17:00	9	1	10	20.0	2	0	2	20.0	
18:00	1	1	2	0.0	0	0	0	0.0	
19:00	1	2	3	33.3	0	1	1	33.3	
20:00	1	0	1	0.0	0	0	0	0.0	
21:00	0	0	0	0.0	0	0	0	0.0	
22:00	0	0	0	0.0	0	0	0	0.0	
23:00	0	0	0	0.0	0	0	0	0.0	
<b>TOTAL</b>	<b>74</b>	<b>73</b>	<b>147</b>	<b>21.8</b>	<b>18</b>	<b>14</b>	<b>32</b>	<b>21.8</b>	



### Peak Statistics

AM	TIME	07:30	05:45	07:30	06:15	07:30	07:30
	VOL	7	15	19	4	3	7
PM	TIME	15:45	13:45	15:45	16:30	13:45	13:45
	VOL	16	5	18	4	3	5

Volume

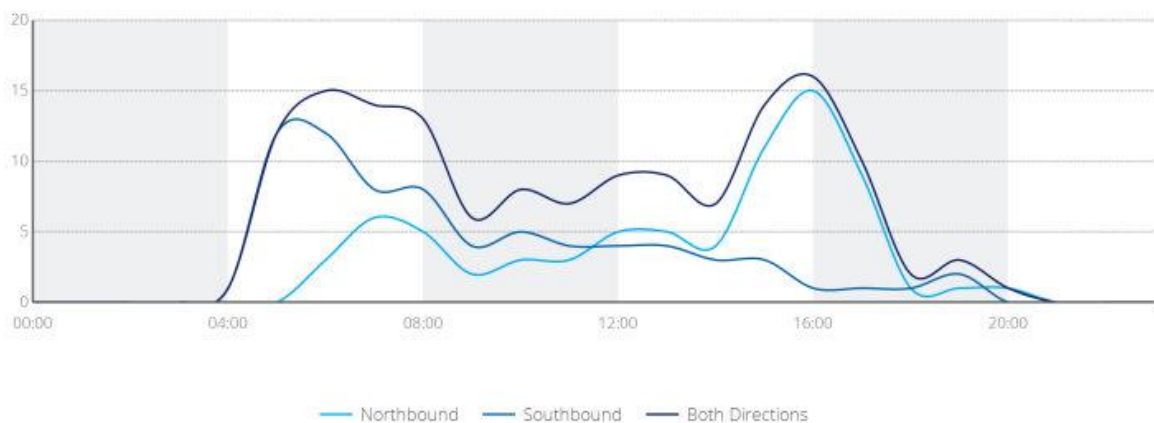



SITE 53258

## Hourly Volume

Leeming Rd (4211128)

2020/21  
 Monday to Sunday

South of Great Eastern Hwy (SLK 4.40)

	All Vehicles			Heavy Vehicles				
	NB	SB	Both	NB	SB	Both	%	
00:00	0	0	0	0	0	0	0.0	
01:00	0	0	0	0	0	0	0.0	
02:00	0	0	0	0	0	0	0.0	
03:00	0	0	0	0	0	0	0.0	
04:00	0	1	1	0	0	0	0.0	
05:00	0	9	9	0	0	0	0.0	
06:00	3	9	12	2	1	3	25.0	
07:00	6	6	12	4	1	5	41.7	
08:00	3	6	9	1	3	4	44.4	
09:00	2	2	4	0	0	0	0.0	
10:00	2	3	5	0	0	0	0.0	
11:00	2	4	6	0	1	1	16.7	
12:00	4	4	8	1	1	2	25.0	
13:00	4	3	7	2	2	4	57.1	
14:00	4	1	5	1	0	1	20.0	
15:00	8	2	10	1	0	1	10.0	
16:00	10	1	11	1	0	1	9.1	
17:00	6	1	7	1	0	1	14.3	
18:00	1	1	2	0	0	0	0.0	
19:00	0	0	0	0	0	0	0.0	
20:00	0	0	0	0	0	0	0.0	
21:00	0	0	0	0	0	0	0.0	
22:00	0	0	0	0	0	0	0.0	
23:00	0	0	0	0	0	0	0.0	
<b>TOTAL</b>	<b>55</b>	<b>53</b>	<b>108</b>	<b>14</b>	<b>9</b>	<b>23</b>	<b>21.3</b>	



### Peak Statistics

AM	TIME	07:00	05:30	<b>05:45</b>	06:30	07:30	<b>07:15</b>
	VOL	6	11	<b>14</b>	4	3	<b>6</b>
PM	TIME	15:45	13:30	<b>15:30</b>	13:15	13:30	<b>13:15</b>
	VOL	11	4	<b>14</b>	3	2	<b>5</b>

Volume

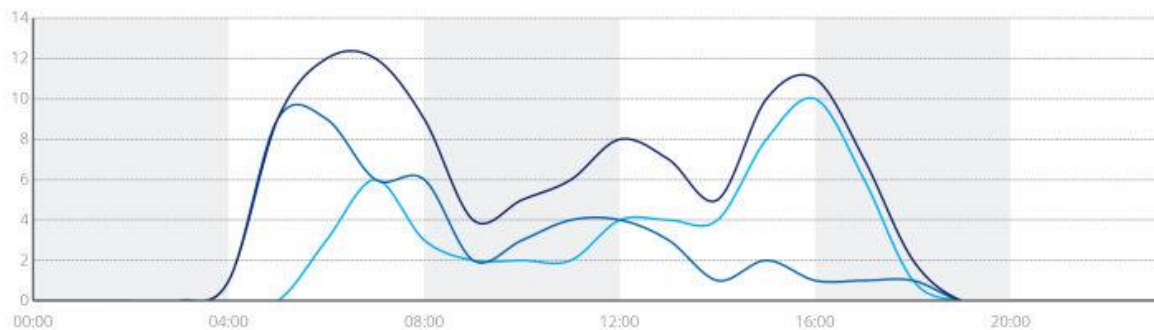

— Northbound — Southbound — Both Directions



SITE 53258

## Hourly Volume

Leeming Rd (4211128)

2020/21  
 Weekend

South of Great Eastern Hwy (SLK 4.40)

	All Vehicles				Heavy Vehicles					
	NB	SB	Both	%	NB	SB	Both	%		
00:00	0	0	0	0.0	0	0	0	0.0		
01:00	0	0	0	0.0	0	0	0	0.0		
02:00	0	0	0	0.0	0	0	0	0.0		
03:00	0	0	0	0.0	0	0	0	0.0		
04:00	0	0	0	0.0	0	0	0	0.0		
05:00	0	3	3	0.0	0	0	0	0.0		
06:00	1	2	3	33.3	1	0	1	33.3		
07:00	2	1	3	33.3	1	0	1	33.3		
08:00	2	1	3	0.0	0	0	0	0.0		
09:00	1	0	1	0.0	0	0	0	0.0		
10:00	1	1	2	0.0	0	0	0	0.0		
11:00	0	1	1	0.0	0	0	0	0.0		
12:00	2	1	3	0.0	0	0	0	0.0		
13:00	3	2	5	40.0	1	1	2	40.0		
14:00	3	0	3	0.0	0	0	0	0.0		
15:00	2	1	3	33.3	1	0	1	33.3		
16:00	1	0	1	0.0	0	0	0	0.0		
17:00	0	0	0	0.0	0	0	0	0.0		
18:00	1	2	3	0.0	0	0	0	0.0		
19:00	0	0	0	0.0	0	0	0	0.0		
20:00	0	0	0	0.0	0	0	0	0.0		
21:00	0	1	1	0.0	0	0	0	0.0		
22:00	0	0	0	0.0	0	0	0	0.0		
23:00	0	0	0	0.0	0	0	0	0.0		
<b>TOTAL</b>	<b>19</b>	<b>16</b>	<b>35</b>	<b>14.3</b>	<b>4</b>	<b>1</b>	<b>5</b>	<b>14.3</b>		

**Peak Statistics**

AM	TIME	07:15	05:00	07:30	06:30	00:00	06:30
	VOL	3	3	5	2	0	2
PM	TIME	13:30	12:45	13:30	15:00	13:30	13:00
	VOL	4	3	6	1	1	2

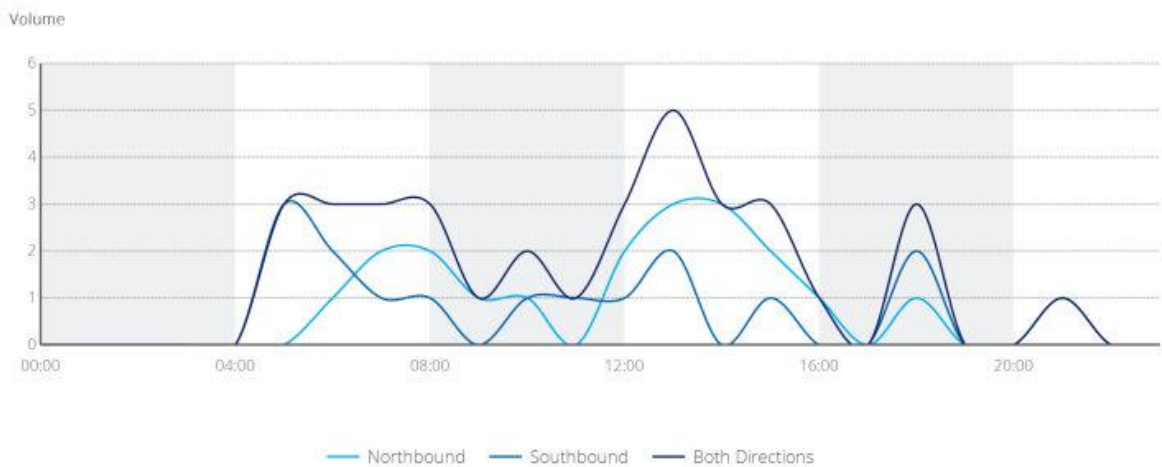

## 12. REPORTS OF COMMITTEE MEETINGS

### 12.1 NYOONGAR CULTURAL ADVISORY GROUP COMMITTEE MEETING HELD ON 14 MAY 2022

#### Receipt of Minutes:

<p><b>RECOMMENDATION / COUNCIL DECISION</b></p> <p><b>Minute No: C.4533</b></p> <p><b>Moved: Cr Ryan</b></p> <p><b>That Council receive the minutes from the Nyoongar Cultural Advisory Group Committee meeting held on 14 May 2022.</b></p> <p style="text-align: right;"><b>CARRIED10/0</b></p>
---

#### Adoption of Recommendations:

<p><b>RECOMMENDATION / COUNCIL DECISION</b></p> <p><b>Minute No: C.4534</b></p> <p><b>Moved: Cr Ryan</b></p> <p><b>That Council:</b></p> <ol style="list-style-type: none"><li><b>1. Accepts the following nominations on the Nyoongar Cultural Advisory Group Committee:</b><ul style="list-style-type: none"><li>○ <b>Ms Donna Moody – representing the Moody Family</b></li><li>○ <b>Yvonne Kickett – representing the Kickett Family</b></li><li>○ <b>Shirley Slater – representing the Slater Family</b></li></ul></li><li><b>2. Receives the Bilya Koort Boodja update as presented.</b></li><li><b>3. Accepts the plan to host an event or events for the week of Reconciliation Week, 27 May 2022 – 3 June 2022.</b></li></ol> <p style="text-align: right;"><b>CARRIED10/0</b></p>
---

Note: This committee was disbanded on 22 July 2022 and replaced with a working group.

**Attachment 1 – Nyoongar Cultural Advisory Group Meeting Minutes 4 May 2022**



Shire of Northam  
*Heritage, Commerce and Lifestyle*

**Shire of Northam**

**Agenda**

**Nyoongar Cultural Advisory**

**Group Meeting**

**4 May 2022**



## DISCLAIMER

These minutes are yet to be dealt with by the Council. The Recommendations shown at the foot of each item have yet to be considered by the Council and are not to be interpreted as being the position of the Council. The minutes of the meeting held to discuss this agenda should be read to ascertain the decision of the Council.

In certain circumstances members of the public are not entitled to inspect material, which in the opinion of the Chief Executive Officer is confidential, and relates to a meeting or a part of a meeting that is likely to be closed to members of the public.

No responsibility whatsoever is implied or accepted by the Shire of Northam for any act, omission, statement or intimation occurring during Council or Committee meetings.

The Shire of Northam disclaims any liability for any loss whatsoever and howsoever caused arising out of reliance by any person or legal entity on any such act, omission or statement of intimation occurring during Council or Committee meetings.

Any person or legal entity who acts or fails to act in reliance upon any statement, act or omission made in a Council or Committee meeting does so at that person's or legal entity's own risk.

In particular and without derogating in any way from the broad disclaimer above, in any discussion regarding any planning application or application for a licence, any statement or intimation of approval made by any member or Officer of the Shire of Northam during the course of any meeting is not intended to be and is not taken as notice of approval from the Shire of Northam.

The Shire of Northam advises that anyone who has any application lodged with the Shire of Northam must obtain and should only rely on **WRITTEN CONFIRMATION** of the outcome of the application and any conditions attaching to the decision made by the Shire of Northam in respect of the application.

The Shire of Northam advises that any plans or documents contained within this agenda may be subject to copyright law provisions (*Copyright Act 1968*, as amended) and that the express permission of the copyright owner(s) should be sought prior to their reproduction. It should be noted that copyright owners are entitled to take legal action against any persons who infringe their copyright. A reproduction of material that is protected by copyright may represent a copyright infringement.

## Contents

1.	DECLARATION OF OPENING.....	4
2.	ACKNOWLEDGEMENT TO COUNTRY.....	4
3.	ATTENDANCE.....	4
3.1	APOLOGIES.....	4
3.2	APPROVED LEAVE OF ABSENCE.....	5
3.3	ABSENT.....	5
4.	DISCLOSURE OF INTERESTS.....	5
5.	RECEIVING OF PETITIONS, PRESENTATIONS AND DEPUTATIONS.....	5
6.	CONFIRMATION OF MINUTES.....	7
6.1	COMMITTEE MEETING HELD ON 6 APRIL 2022.....	7
7.	COMMITTEE REPORTS.....	7
7.2	NOMINATION MEMBERSHIP ON THE NYOONGAR CULTURAL ADVISORY GROUP COMMITTEE – DONNA MOODY.....	7
7.1	BILYA KOORT BOODJA UPDATE.....	10
7.5	PLANNING FOR NATIONAL RECONCILIATION WEEK EVENT 27 MAY – 3 JUNE 2022.....	14
7.3	TRACKS & TRAILS MASTER PLAN CONSULTATION.....	19
7.4	CULTURAL AWARENESS VIDEO.....	24
7.6	REVIEW OF THE TERMS OF REFERENCE FOR THE NYOONGAR CULTURAL ADVISORY GROUP.....	26
8.	URGENT BUSINESS APPROVED BY DECISION.....	31
9.	DATE OF NEXT MEETING.....	31
10.	DECLARATION OF CLOSURE.....	31

Nyoongar Cultural Advisory Group Committee Minutes  
04 May 2022



## 1. DECLARATION OF OPENING

The Chairperson Cr Michael Ryan declared the meeting open at 3.35pm

## 2. ACKNOWLEDGEMENT TO COUNTRY

The Shire of Northam would like to acknowledge the Traditional Owners of the land on which we meet, the Ballardong people of the Nyoongar nation and pay our respects to Elders, past present and emerging.

- Cr Michael Ryan gave an Acknowledgement of Country, followed by a Welcome to Country by Mrs Deborah Moody. It was noted that if an Elder is present, they should be give the Welcome to Country.

## 3. ATTENDANCE

### Committee:

Councillors

Moody Family  
McGuire Family  
Davis Family

ATSI Representative  
Stack Family

M P Ryan  
A J Mencshelyi  
Julie Wynne  
Deborah Moody  
Jermaine Davis (left the meeting 5:00pm)  
Brenda DeAtta  
Elizabeth Stack (arrived 4:29pm)

### Staff:

CEO  
Exec. Manager Community Services  
Community Development Officer  
Manager Communications & Tourism

Jason Whiteaker  
Jo Metcalf  
Jaime Hawkins  
Vic Williams

### Guests:

Donna Moody  
Boyd Kickett  
Yvonne Kickett  
Shirley Slater

### 3.1 APOLOGIES

BKB Centre Coordinator  
Ryder Family  
Davis Family

Robyn Davis  
Vivienne Ryder  
Kathy Davis

Nyoongar Cultural Advisory Group Committee Minutes  
04 May 2022

### 3.2 APPROVED LEAVE OF ABSENCE

Nil.

### 3.3 ABSENT

Ryder Family  
Moody Family  
Garlett Family  
Stack Family  
McGuire Family

Joan Parfitt  
Priscilla Moody  
Kirk Garlett  
Kate Stack  
Maria Nickels

## 4. DISCLOSURE OF INTERESTS

Nil.

## 5. RECEIVING OF PETITIONS, PRESENTATIONS AND DEPUTATIONS

### 5.1 JASON WHITEAKER - INDUCTION COMMITTEE OF COUNCIL

#### DISCUSSION

- Ms Donna Moody requested the structure & process of meeting be considered. The meeting held 6 April the agenda was rushed through, and Elders were not given adequate time for consideration. It was agreed that the presentations at the previous meeting were time consuming and these be limited in the future.
- Ms Donna Moody questioned whether there was to be the opportunity for the Elders to take ownership of the Committee. CEO, Jason Whiteaker explained the position of the NCAG as a formal Committee of Council established under the Local Government Act. How the committee is run is governed by the Act. The Elders cannot take ownership of the Committee but can take leadership roles. Being a Committee of Council, the Elders are given a strong voice on cultural matters and decisions made are reported directly back to Council and are to be actioned.
- Mrs Deborah Moody asked why the committee are not receiving sitting fees. Mr Jason Whiteaker explained that the Local Government Act precluded the Shire from paying people to sit on Committees of Council. Ms Shirley Slater asked if this is something that Council can change their policy on, in which Mr Whiteaker explained that it is State Government legislation, and the Shire of Northam Council has no power to change it and must follow the legislation.

Nyoongar Cultural Advisory Group Committee Minutes  
04 May 2022



Mr Whiteaker stated that he hoped the Committee would see the bigger picture beyond the issue of payment for meeting attendance and leave a legacy for future generations by ensuring Council is celebrating Aboriginal Culture and capturing cultural knowledge for the community so this is not lost. Guidance is provided by the committee, however stories are collected outside the operations of the Committee and individuals are paid for their time when recording stories and knowledge.

Ms Donna Moody requested that the CEO, Jason Whiteaker investigates ways the Committee could be restructured so Elders and the Aboriginal Community can benefit from payment of their personal time and knowledge. Mr Whiteaker stated that Council could look at the NCAG becoming an informal group, who would then be eligible to receive payment, but in doing this the Committee would lose its strength of having a direct line to Council, where decisions made at NCAG meetings are reported to Council for implementation.

Mr Jermaine Davis stated that when invited to nominate, it was clearly raised to him that it was not to be a paid position to sit on the NCAG, that it was to be a voluntary role. He suggested that each Elder could be contacted to raise and communicate issues and concerns to be discussed at the meeting rather than getting a set agenda they have no input into. Mr Whiteaker agreed that 10 minutes could be dedicated to the start or conclusion of the meeting for Elders to raise topics and issues for discussion.

The Council Committee meeting Code of Conduct was distributed to committee.

\*Ms Elizabeth Stack entered the meeting at 4:29pm.

Nyoongar Cultural Advisory Group Committee Minutes  
04 May 2022



## 6. CONFIRMATION OF MINUTES

### 6.1 COMMITTEE MEETING HELD ON 6 APRIL 2022

#### RECOMMENDATION / COUNCIL DECISION

Minute No: NCAG. 31  
Moved: Ms Julie Wynne  
Seconded: Cr Attila Mencshelyi

That the minutes of the Nyoongar Cultural Advisory Group meeting held on 6 April 2022 be confirmed as a true and correct record of that meeting, subject to the correction of the spelling of Cr. Attila Mencshelyi on page 16.

CARRIED 7/0

## 7. COMMITTEE REPORTS

Agenda item 7.2 was brought forward.

### 7.2 NOMINATION MEMBERSHIP ON THE NYOONGAR CULTURAL ADVISORY GROUP COMMITTEE – DONNA MOODY

File Reference:	2.1.3.7
Reporting Officer:	Jaime Hawkins, Community Development Officer
Responsible Officer:	Jo Metcalf, Executive Manager Community Services
Officer Declaration of Interest:	Nil
Voting Requirement:	Simple Majority
Press release to be issued:	Nil

#### BRIEF

For the Committee to accept the nomination of Donna Moody on to the Nyoongar Cultural Advisory Committee to represent the Moody Family.

ATTACHMENTS Nil

#### A. BACKGROUND / DETAILS

Nyoongar Cultural Advisory Group Committee Minutes  
04 May 2022



Ms Donna Moody was previously endorsed as a member of the Nyoongar Cultural Advisory Group in 2019, however was unable to attend meetings. Following her attendance at the meeting held 6 April 2022, Ms Moody submitted a nomination form to join the Committee representing the Moody Family on behalf of her father who is a Moody Elder.

The Moody Family also have Mrs Julie Wynne and Ms Priscilla Moody as current representatives. Only one family representative is eligible to vote, other members can be nominated as Proxy members and attendance at meetings is open to the public.

**B. CONSIDERATIONS**

**B.1 Strategic Community / Corporate Business Plan**

Theme Area 4: Environment and Heritage  
Outcome 4.2: Northam honours, and is recognised for, its unique heritage and cultural identity  
Objective: There is a strong, respected and valued Aboriginal community and culture in the Shire of Northam

**B.2 Financial / Resource Implications**

Nil.

**B.3 Legislative Compliance**

Nil.

**B.4 Policy Implications**

Nil.

**B.5 Stakeholder Engagement / Consultation**

Calls for Expressions of Interest to join the Committee were advertised via social media and the Shire website.

**B.6 Risk Implications**

Risk Category	Description	Rating (likelihood x consequence)	Mitigation Action
Financial	N/A		
Health & Safety	N/A		
Reputation	Membership on the committee is not seen as representative of the Northam Ballardong Nyoongar Community.	Unlikely(2) x Minor(2) = Low (4)	Shire develops Terms of Reference and appoints representation in consultation with Ballardong Nyoongar Elders.

Nyoongar Cultural Advisory Group Committee Minutes  
04 May 2022



Service Interruption	N/A		
Compliance	N/A		
Property	N/A		
Environment	N/A		

**C. OFFICER'S COMMENT**

The Committee are to be given the opportunity to consider the nomination received from Ms Donna Moody as a representative of the Moody Family.

**DISCUSSION**

Further nominations received at the meeting from Mrs Yvonne Kickett and Ms Shirley Slater.

**RECOMMENDATION**

That Council accepts the nomination of Ms Donna Moody, on the Nyoongar Cultural Advisory Group Committee.

**RECOMMENDATION / COUNCIL DECISION**

Minute No: NCAG. 33  
Moved: Cr Michael Ryan  
Seconded: Mrs Deborah Moody

That Council accepts the following nominations on the Nyoongar Cultural Advisory Group Committee:

- Ms Donna Moody – representing the Moody Family
- Yvonne Kickett – representing the Kickett Family
- Shirley Slater – representing the Slater Family

**CARRIED 7/0**



Nyoongar Cultural Advisory Group Committee Minutes  
04 May 2022



**7.1 BILYA KOORT BOODJA UPDATE**

<b>File Reference:</b>	1.3.13.5
<b>Reporting Officer:</b>	Robyn Davis, BKB Coordinator
<b>Responsible Officer:</b>	Jo Metcalf, Executive Manager Community Services
<b>Officer Declaration of Interest:</b>	Nil.
<b>Voting Requirement:</b>	Simple Majority
<b>Press release to be issued:</b>	Nil.

**BRIEF**

For the Committee to receive an update on the Bilya Koort Boodja Centre.

**ATTACHMENTS**

Nil.

**A. BACKGROUND / DETAILS**

The Bilya Koort Boodja is the Aboriginal Interpretive Centre in the Shire of Northam, offering visitors a visual and immersive experience into Aboriginal culture, heritage and traditions through various displays and events.

**A.1 Visitor Numbers**

Month	BKB visitations - Normal	BKB visitations - Free Pass	BKB visitations - Concessions	BKB visitations - Average per day	BKB Entry Fees
APRIL 21	200	1	122	10.76	\$2610.00
MAY 21	149	0	111	8.38	\$2045.00
JUNE 21	161	0	96	8.56	\$2090.10
JULY 21	182	0	129	10.03	\$2465
AUG 21	199	1	121	10.32	\$2595
SEPT 21	251	0	126	12.56	\$3140
OCT 21	233	4	180	13.32	\$3230
NOV 21	126	0	78	6.8	\$1650
DEC 21	105	0	134	7.70	\$1720

Month	BKB visitations -	BKB visitations -	BKB visitations	BKB visitations -	BKB Entry Fees

Nyoongar Cultural Advisory Group Committee Minutes  
04 May 2022



	Single Entry	Annual Membership	– Free Pass	Average per day	
JAN 22	176	2	0	5.74	\$920
FEB 22	47	0	2	1.75	\$235
MARCH 22	195	2	0	6.35	\$985
APRIL – TO DATE	327	0	0	10.90	\$480

## A.2 Programmed Activities

Upcoming Programs;

NAIDOC

Ms Robyn Davis will provide an update on planned activities for the Bilya Koort Boodja Centre.

## A.3 Marketing

An update to be provided by Ms Jo Metcalf.

## B. CONSIDERATIONS

### B.1 Strategic Community / Corporate Business Plan

Theme Area 4: Environment and Heritage.

Outcome 4.2: Northam honours, and is recognised for, its unique heritage and cultural identity.

Objective: There is a strong, respected and valued Aboriginal community and culture in the Shire of Northam.

### B.2 Financial / Resource Implications

Nil.

### B.3 Legislative Compliance

Nil.

### B.4 Policy Implications

Nil.

### B.5 Stakeholder Engagement / Consultation

Nil.

### B.6 Risk Implications

Risk Category	Description	Rating (likelihood x	Mitigation Action
---------------	-------------	----------------------	-------------------

Nyoongar Cultural Advisory Group Committee Minutes  
04 May 2022

		consequence	
Financial	The Centre fails to reach financial sustainability	Possible (3) x Medium (3)= 9 (Medium)	Development of marketing plan to promote centre  Secure external funding
Health & Safety	N/A		
Reputation	The Centre fails to provide an experience that delivers on expectation	Possible (3) x Medium (3)= 9 (Medium)	Ensure weekend activities are in place
Service Interruption	N/A		
Compliance	N/A		
Property	N/A		
Environment	N/A		

### C. OFFICER'S COMMENT

Tourism Australia brief – Wanting to do some filming on 9<sup>th</sup> May to promote the BKB experience. Looking for Talent to be involved in the project.

Thylacine update – Collection of stories.

### DISCUSSION

An update was provided by the Executive Manager Community Services, Ms Jo Metcalf.

- The Northam Yorga's Group are now meeting at the BKB.
- Tourism WA will be doing a photo shoot on the 9<sup>th</sup> May and the TV show Getaway will be featuring the BKB in a piece on the Avon Valley.

Mrs Victoria Williams gave an update on Stage 2 of the BKB.

- The Shire has funding for upgrades and repairs for existing things within the centre.
- The graphic as you enter the exhibition is to be changed.
- There will be new installations in the Welcome Space to give the impression of trees and new lighting effects.
- Some of the graphics of the wall panels are to be re-done, including the first panel where feedback has been that writing is too small.
- New stories will be collected from those who are yet to be captured, both written and video.

Nyoongar Cultural Advisory Group Committee Minutes  
04 May 2022



- Glitches to the touch screen will be repaired, so that all of the content doesn't pop up on the screen at once.
- Season monitors will be re-programmed and fitted with new speakers.
- The lighting will be improved to highlight the names on the wooden beams in the sorry space, as they are barely visible at the moment.
- Speakers will be upgraded to include directional speakers, as the sounds are currently competing with each other.
- There will be new showcases installed in the shop area for the stock. These will also be designed to provide better theft prevention.
- A digital screen will be installed out the front of the centre to highlight the exhibition and give people a glimpse of what they are paying for if they come in.

Ms Shirley Slater asked if the stories of the Ballardong soldiers be included in the updates to the exhibition, as she believes this will provide greater interest for the schools. Mrs Victoria Williams said that these could be programmed in to feature seasonally around ANZAC Day and Remembrance Day.

Ms Jo Metcalf updated the Committee that the BKB Centre Coordinator, Ms Robyn Davis has resigned. She will be finishing on 17 May 2022. Mr Jason Whiteaker, advised that an Elder is to sit on the interview panel for the selection of the new BKB Centre Coordinator. Mrs Yvonne Kickett recommended that Mrs Kathy Davis and Mrs Deborah Moody are the best Elders to be on the selection panel for the recruitment of the new Coordinator.

Ms Jo Metcalf provided an update on the Community Arts Network Noongar Lullabies Project. Session one was very successful, and on Friday 6 May ABC TV will be filming for national TV for a program on arts programs and community wellbeing. Ms Metcalf encouraged the committee to attend and advise others in the community to attend. It was suggested by Ms Donna Moody that Clontarf Academy and the Wirrpanda Girls be contacted to see if they are able to attend.

Nyoongar Cultural Advisory Group Committee Minutes  
04 May 2022



**RECOMMENDATION / COUNCIL DECISION**

**Minute No:** NCAG. 32

**Moved:** Mrs Deborah Moody

**Seconded:** Ms Shirley Slater

That Council receives the Bilya Koort Boodja update as presented.

**CARRIED 7/0**

\*Mr Jermaine Davis left the meeting at 5:00pm.

Agenda item 7.5 was brought forward.

**7.5 PLANNING FOR NATIONAL RECONCILIATION WEEK EVENT 27 MAY – 3 JUNE 2022**

<b>File Reference:</b>	2.1.3.7
<b>Reporting Officer:</b>	Jaime Hawkins, Community Development Officer
<b>Responsible Officer:</b>	Jo Metcalf, Executive Manager Community Services
<b>Officer Declaration of Interest:</b>	Nil
<b>Voting Requirement:</b>	Simple Majority
<b>Press release to be issued:</b>	Nil

**BRIEF**

National Reconciliation Week (NRW) is a time for all Australians to learn about our shared histories, cultures, and achievements, and to explore how each of us can contribute to achieving reconciliation in Australia. National Reconciliation Week is from 27<sup>th</sup> May to the 3<sup>rd</sup> June. These dates commemorate two significant milestones in the reconciliation journey— the successful 1967 referendum, and the High Court Mabo decision respectively. The theme for Reconciliation Week 2022 is "Be Brave. Make Change"

**ATTACHMENTS**

Attachment 4: National Reconciliation Week Poster 2022

**A. BACKGROUND / DETAILS**

Nyoongar Cultural Advisory Group Committee Minutes  
04 May 2022



Since 2018 the Shire of Northam has hosted community National Reconciliation Week events, with the exception of 2020 where Covid restrictions meant that a community gathering could not take place, so the event was recognised online.

The National Reconciliation Week 2022 theme, "Be Brave. Make Change." is a challenge to all Australians— individuals, families, communities, organisations and government—to Be Brave and tackle the unfinished business of reconciliation so we can Make Change for the benefit of all Australians.

This year Reconciliation Australia are asking everyone to make change beginning with brave actions in their daily lives – where they live, work, play and socialise.

National Reconciliation Week—27 May to 3 June—is a time for all Australians to learn about our shared histories, cultures, and achievements, and to explore how each of us can contribute to achieving reconciliation in Australia.

<https://nrw.reconciliation.org.au>

## B. CONSIDERATIONS

### B.1 Strategic Community / Corporate Business Plan

Theme Area 4: Environment and Heritage  
Outcome 4.2: Northam honours, and is recognised for, its unique heritage and cultural identity  
Objective: There is a strong, respected and valued Aboriginal community and culture in the Shire of Northam

### B.2 Financial / Resource Implications

There is a small financial and resource implication to undertake activities relating to Reconciliation Week.

### B.3 Legislative Compliance

Nil.

### B.4 Policy Implications

Nil.

### B.5 Stakeholder Engagement / Consultation

The previous RAP Working Group are being consulted about planning a NRW event.

### B.6 Risk Implications

Risk Category	Description	Rating (likelihood x consequence)	Mitigation Action

Nyoongar Cultural Advisory Group Committee Minutes  
04 May 2022



Financial			
Health & Safety	N/A		
Reputation	Shire of Northam is seen as not supportive of reconciliation	Unlikely(2) x Minor(2) = Low (4)	Shire develops RAP in consultation with RAP Working group and endorsement of Reconciliation Australia
Service Interruption	N/A		
Compliance	N/A		
Property	N/A		
Environment	N/A		

**C. OFFICER'S COMMENT**

To commemorate National Reconciliation Week 2022, it is proposed that the Shire of Northam in conjunction with the Nyoongar Cultural Advisory Group host a celebration on Friday 27 May 2022 at the Bilya Koort Boodja Centre. The event will include:

- Welcome to Country.
- Official address by the Shire President or Chairperson of the NCAG and representatives.
- Kangaroo stew and damper for morning tea or lunch for invited guests and community, including NCAG members, Elders, Shire of Northam Councillors and staff, local parliamentary representatives, Northam Police, government agencies and local businesses.
- Growing of the BKB Reconciliation Tree with individuals to place a new leaf on the tree with a message of reconciliation.
- Free entry to the BKB exhibition for the day.

**DISCUSSION**

Ms Elizabeth Stack suggested an event in the CBD, such as the Village Green would be preferable so it is more visible to the community.

Ms Donna Moody suggested the entire week should be commemorated, not just have a one day event.

Ms Shirley Slater and Elizabeth Stack nominated to assist with Reconciliation Week planning.

**RECOMMENDATION**

That Council accepts the plans to host a National Reconciliation Week event on Friday 27 May at the Bilya Koot Boodja Centre, with free entry to the exhibition for the day.

**RECOMMENDATION / COUNCIL DECISION**

Minute No: NCAG. 34

Moved: Ms Donna Moody

Seconded: Ms Brenda DeAtta

That Council accepts the plan to host an event or events for the week of Reconciliation Week, 27 May 2022 – 3 June 2022.

**CARRIED 6/0**

Reason for change to Officer Recommendation

Following the recommendations from Ms Elizabeth Stack and Donna Moody the Committee formed the view that the entire week should be celebrated, rather than just one day.



Attachment 4: National Reconciliation Week 2022 Poster

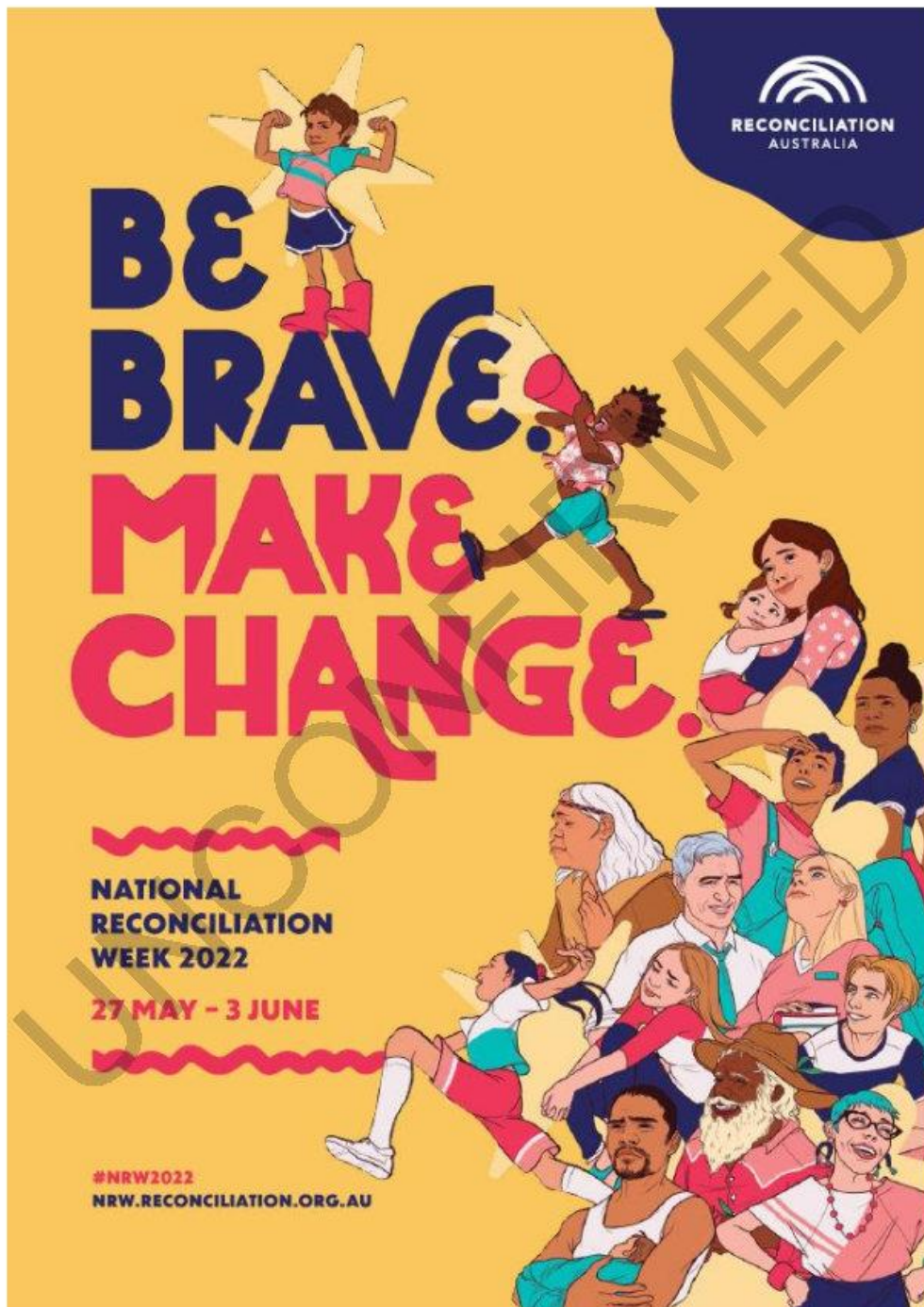

Nyoongar Cultural Advisory Group Committee Minutes  
04 May 2022



Agenda Item 7.3 was not considered at the meeting.

### 7.3 TRACKS & TRAILS MASTER PLAN CONSULTATION

<b>File Reference:</b>	2.1.3.7
<b>Reporting Officer:</b>	Jaime Hawkins, Community Development Officer
<b>Responsible Officer:</b>	Jo Metcalf, Executive Manager
<b>Officer Declaration of Interest:</b>	Nil
<b>Voting Requirement:</b>	Simple Majority
<b>Press release to be issued:</b>	Nil

#### BRIEF

For the committee to provide input into the tracks and trails master plan.

#### ATTACHMENTS

Attachment 1: Base Map  
Attachment 2: Consultation Questions

#### A. BACKGROUND / DETAILS

At the meeting held 6 April 2022, Ms Megan Watson from Common Ground Trails made a presentation to the committee regarding the development of the Shire of Northam Tracks & Trails Master Plan. Ms Watson called for input from the advisory group regarding significant sites that have a story that can be shared, and sacred areas that are to be avoided all together. In particular, the Dornij Koorliny Trail was focused on.

Feedback forms were emailed to those with email access and were also made available from the BKB. No responses have been received.

#### B. CONSIDERATIONS

##### B.1 Strategic Community / Corporate Business Plan

Theme Area 4: Environment and Heritage  
Outcome 4.2: Northam honours, and is recognised for, its unique heritage and cultural identity  
Objective: There is a strong, respected and valued Aboriginal community and culture in the Shire of Northam

##### B.2 Financial / Resource Implications

Nil

##### B.3 Legislative Compliance

Nyoongar Cultural Advisory Group Committee Minutes  
04 May 2022



Nil.

**B.4 Policy Implications**

Nil.

**B.5 Stakeholder Engagement / Consultation**

The Nyoongar Cultural Advisory Group were consulted with at the meeting held 6 April 2022 and feedback forms made available.

**B.6 Risk Implications**

Risk Category	Description	Rating (likelihood x consequence)	Mitigation Action
Financial	N/A		
Health & Safety	N/A		
Reputation	There are significant reputational risks should Council construct a track through a sacred area.	Major (4) x Unlikely (2) = Moderate (8)	Ensure extensive consultation with Aboriginal Elders and Community.
Service Interruption	N/A		
Compliance	N/A		
Property	N/A		
Environment	Tracks and trails have a detrimental impact on natural environment.	Medium (3) x Unlikely (2) = Moderate (6)	Thorough research and consultation before the planning and construction of any tracks and trails through natural bushland.

**C. OFFICER'S COMMENT**

The Committee are to be given the opportunity to provide any further feedback on the tracks and trails. It is requested that feedback forms be completed and returned as soon as possible.

Further consultation will occur prior to the endorsement of the final plan.

Nyoongar Cultural Advisory Group Committee Minutes  
04 May 2022

Attachment 1: Base Map

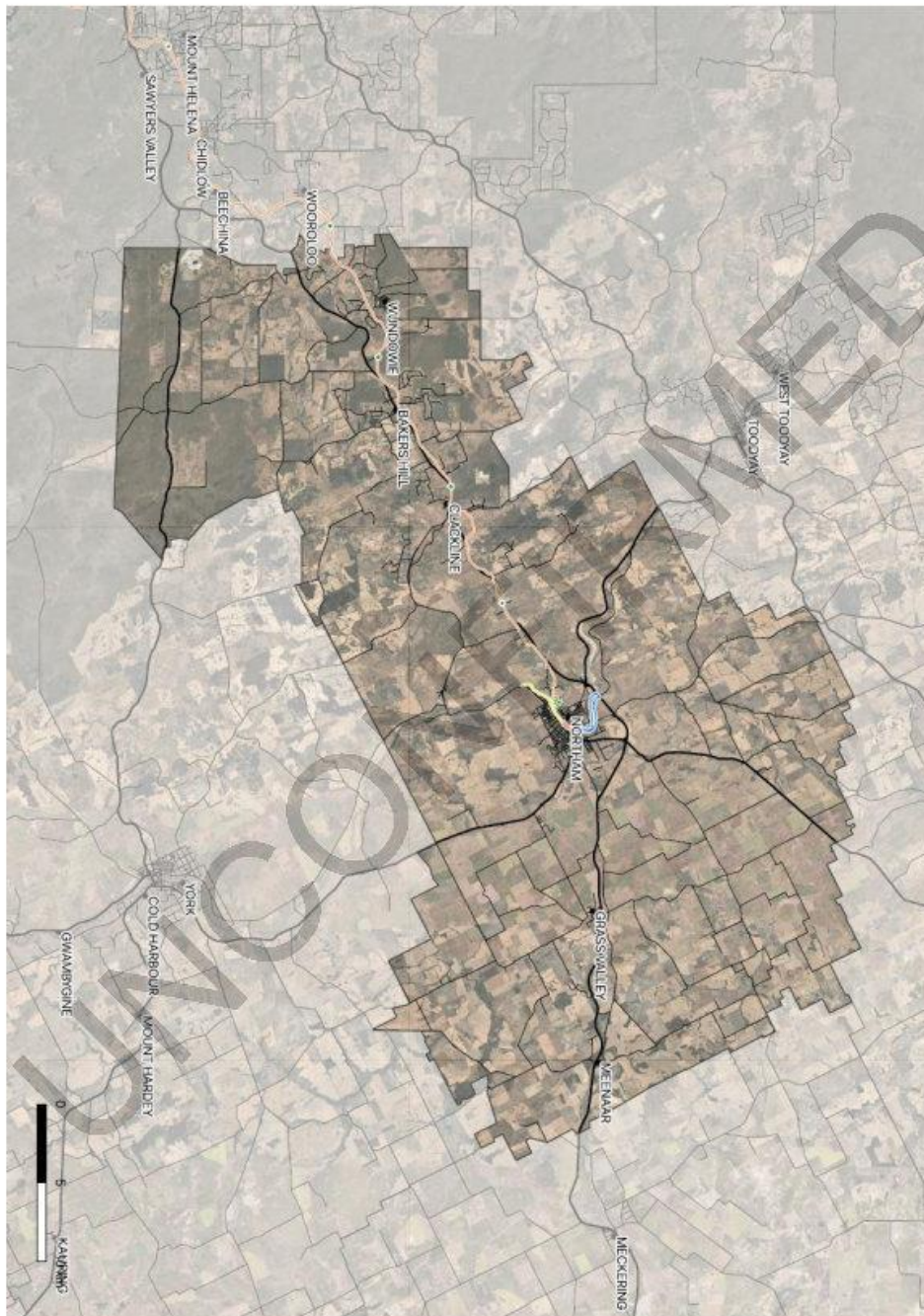

Nyoongar Cultural Advisory Group Committee Minutes  
04 May 2022

Attachment 2: Consultation Questions



Consultation & Engagement – Cultural Leaders

NAME		DATE	
LEADERSHIP ROLE			

OVERVIEW	<p>The Trails Master Plan recommends that the Shire focus on celebrating cultural and environmental values as a key point of difference.</p> <p>The signature trail experiences are proposed to have a focus on opportunities to connect trail users to the cultural heritage values in the area.</p> <p><b>Example</b> The Dorntj Koorliny Trail is proposed to connect trail users from the BKB Centre to Burlong Pool and the confluence of the Avon and Mortlock Rivers as key sites of cultural significance with opportunities for self-guided or guided cultural tours.</p>
----------	--

QUESTION	COMMENT / FEEDBACK
<p>Key sites of cultural significance identified in the Plan. Are Elders and Leaders comfortable with promoting access to:</p> <ul style="list-style-type: none"> <li>• Avon River,</li> <li>• Burlong Pool and</li> <li>• Enright Park</li> </ul>	
<p>Are there stories or other sites that have potential to be incorporated into interpretation signs or tours? If so where? What is the story or site? How could we obtain further information?</p>	
<p>Is there a desire to be involved in ongoing implementation of the Master Plan proposals? <b>Example</b></p> <ul style="list-style-type: none"> <li>• Involvement in refining trail ideas,</li> <li>• Developing and running tours once trails are in place,</li> <li>• Development of ranger program to maintain trails</li> </ul>	
<p>Are there specific sensitive environment ecosystems or old growth trees that they Shire should identify and ensure are appropriately protected?</p>	

Created By	David Emery
Date	6 April 2022
Version	1

Nyoongar Cultural Advisory Group Committee Minutes  
**04 May 2022**



Where are these located? Is it of benefit to highlight these areas for trail users and provide information about protecting these ecosystems? Is there cultural significance to these ecosystems?	
In your opinion what benefits are there culturally on implementing a 'Trails Masterplan' within the Shire of Northam boundary?	
Were there any other cultural considerations that you would like to provide that may need to be considered with the implementation or planning for the 'Trails Masterplan'?	
Other Comments:	

**IMPORTANT** – This feedback is to be returned to [reccoord@northam.wa.gov.au](mailto:reccoord@northam.wa.gov.au) no later than 4pm Friday 22 April 2022.

Should you require further assistance please contact the Shire's Manager Recreation Services, David Emery on 962257 53 or the above email address.

Your Details	
Preferred Contact Person:	
Email address	
Contact No:	

Name: \_\_\_\_\_

Signed: \_\_\_\_\_

Created By	David Emery
Date	6 April 2022
Version	1

Nyoongar Cultural Advisory Group Committee Minutes  
04 May 2022



Agenda Item 7.4 was not considered at the meeting.

#### 7.4 CULTURAL AWARENESS VIDEO

<b>File Reference:</b>	2.1.3.7
<b>Reporting Officer:</b>	Bev Jones, Human Resources Manager
<b>Responsible Officer:</b>	Jason Whiteaker, Chief Executive Officer
<b>Officer Declaration of Interest:</b>	Nil
<b>Voting Requirement:</b>	Simple Majority
<b>Press release to be issued:</b>	Nil

#### BRIEF

To seek a recommendation from the Committee regarding the use of a cultural awareness training video produced for the Public Sector Commission for Shire of Northam staff.

#### ATTACHMENTS

Attachment 3: Video link (sent as a separate attachment)

#### A. BACKGROUND / DETAILS

The Shire of Northam is seeking to develop a cultural awareness package for new and existing staff. In the meantime, a video produced for the Public Sector Commission has been identified to fill the gap. This agenda item has been carried over from the previous meeting held 6 April 2022.

#### B. CONSIDERATIONS

##### B.1 Strategic Community / Corporate Business Plan

Theme Area 4: Environment and Heritage  
Outcome 4.2: Northam honours, and is recognised for, its unique heritage and cultural identity  
Objective: There is a strong, respected and valued Aboriginal community and culture in the Shire of Northam

##### B.2 Financial / Resource Implications

Nil.

##### B.3 Legislative Compliance

Nil.

Nyoongar Cultural Advisory Group Committee Minutes  
04 May 2022



**B.4 Policy Implications**

Nil.

**B.5 Stakeholder Engagement / Consultation**

Nil.

**B.6 Risk Implications**

Risk Category	Description	Rating (likelihood x consequence)	Mitigation Action
Financial	N/A		
Health & Safety	N/A		
Reputation	The video is presented for staff inductions, however is not culturally accurate for the Ballardong region.	Unlikely (2) x Minor (2) = Low (4)	Video is endorsed by the NCAG prior to be integrated into the workplace induction package.
Service Interruption	N/A		
Compliance	N/A		
Property	N/A		
Environment	N/A		

**C. OFFICER'S COMMENT**

Cultural training in the workplace can enhance cultural sensitivity, competence and most importantly eliminate the risk of major miscommunication. The implementation of a tailored cultural awareness training package for Shire of Northam staff will enhance cultural understanding which will in turn encourage positive cross-cultural working relationships as well as positive relationships outside of work. Whilst the package is being created in preparation for endorsement by the Nyoongar Cultural Advisory Group, a video produced by the Public Sector Commission has been identified to hopefully educate staff and make them more culturally aware.

**RECOMMENDATION**

That Council accept the video produced by the Public Sector Commission to be used for staff cultural awareness training until the Shire's own training package is developed.



Nyoongar Cultural Advisory Group Committee Minutes  
04 May 2022



Agenda Item 7.6 was not considered at the meeting.

**7.6 REVIEW OF THE TERMS OF REFERENCE FOR THE NYOONGAR CULTURAL ADVISORY GROUP**

<b>File Reference:</b>	2.1.3.7
<b>Reporting Officer:</b>	Jaime Hawkins, Community Development Officer
<b>Responsible Officer:</b>	Jo Metcalf, Executive Manager Community Services
<b>Officer Declaration of Interest:</b>	Nil
<b>Voting Requirement:</b>	Simple Majority
<b>Press release to be issued:</b>	Nil

**BRIEF**

For the Committee to consider changes to the Terms of Reference for the Nyoongar Cultural Advisory Group.

**ATTACHMENTS**

Attachment 5: Terms of Reference Nyoongar Cultural Advisory Group with proposed changes

**A. BACKGROUND / DETAILS**

The current Terms of Reference states the following under Membership of the Committee:

The Advisory Group shall consist of elected members, designated Shire of Northam employees and Aboriginal and Torres Strait Islander community members as follows:

- Two (2) Elected Members and Two (2) Proxy Elected Members;
- One representative from each of the following families and one proxy representative;
  - Ryder
  - Garlett
  - Stack
  - Slater
  - McGuire
  - Kickett
  - Moody
  - Davis
- Two other Aboriginal and/or Torres Strait Islander Community Representatives

Nyoongar Cultural Advisory Group Committee Minutes  
04 May 2022



- Shire of Northam CEO or nominated Executive Manager.
- Member for Central Wheatbelt, State Legislative Assembly
- Member of the WA Police Force
- The CEO and or their nominee is to attend all meetings to provide advice and guidance to the committee. They do not have voting rights on the committee
- The local government shall provide secretarial and administrative support to the committee.

It is recommended that the Member for Central Wheatbelt, State Legislative Assembly; and member of the WA Police Force be removed as voting members of the committee and attendance be by invitation. It is also recommended that the Shire of Northam CEO or nominated Executive Manager be removed and the line remain that they shall attend all meetings to provide advice and guidance to the committee. They do not have voting rights on the committee.

## B. CONSIDERATIONS

### B.1 Strategic Community / Corporate Business Plan

Theme Area 4: Environment and Heritage  
Outcome 4.2: Northam honours, and is recognised for, its unique heritage and cultural identity  
Objective: There is a strong, respected and valued Aboriginal community and culture in the Shire of Northam

### B.2 Financial / Resource Implications

Nil.

### B.3 Legislative Compliance

Nil.

### B.4 Policy Implications

Nil.

### B.5 Stakeholder Engagement / Consultation

Nil.

### B.6 Risk Implications

Risk Category	Description	Rating (likelihood x consequence)	Mitigation Action
Financial	N/A		
Health & Safety	N/A		

Nyoongar Cultural Advisory Group Committee Minutes  
04 May 2022



Reputation	Membership on the committee is not seen as representative of the Northam Ballardong Nyoongar Community.	Unlikely(2) x Minor(2) = Low (4)	Shire develops Terms of Reference and appoints representation in consultation with Ballardong Nyoongar Elders.
Service Interruption	N/A		
Compliance	N/A		
Property	N/A		
Environment	N/A		

**C. OFFICER'S COMMENT**

It is recommended that the Member for Central Wheatbelt, State Legislative Assembly; and member of the WA Police Force be removed as voting members and it be stated that their attendance shall be by invitation and they do not have voting rights (see attachment). These changes are proposed as not all meetings will have agenda items of relevance to these organisations and their non-attendance could result in the Committee not reaching a quorum. Voting on the committee should be reserved for the nominated Aboriginal representatives.

The Shire of Northam CEO or nominated Executive Manager is listed as a member of the Committee, however it is also stated further down that they shall attend all meetings to provide advice and guidance to the committee, but do not have voting rights on the committee. It is proposed they are removed from the membership list to avoid confusion.

**RECOMMENDATION**

**That Council accepts the changes to Membership of the Committee in the Nyoongar Cultural Advisory Group Terms of Reference as presented.**

Attachment 5: Terms of Reference with Proposed Changes

*Nyoongar Cultural Advisory Group Terms of Reference 2021 to 2023*

**TERMS OF REFERENCE  
SHIRE OF NORTHAM NYOONGAR CULTURAL ADVISORY GROUP**

**1. Objectives of the Shire of Northam NYOONGAR CULTURAL ADVISORY Group (NCAG)**

The primary objective of NCAG is to provide guidance and recommendations to the Shire of Northam on all Nyoongar related matters focusing on the BKB Centre for Nyoongar Culture & Environmental Knowledge and the development of a community wide Reconciliation Action Plan.

**2. Powers of the Northam NCAG**

NCAG is a formally appointed committee of Council and is responsible to that body. NCAG does not have executive powers or authority to implement actions in areas over which the CEO has legislative responsibility and does not have any delegated financial responsibility. NCAG does not have any management functions and cannot involve itself in management processes or procedures.

NCAG is to report to Council and provide appropriate advice and recommendations on matters relevant to its terms of reference in order to facilitate informed decision-making by Council in relation to the legislative functions and duties of the local government that have not been delegated to the CEO.

**3. Membership**

The Advisory Group shall consist of elected members, designated Shire of Northam employees and Aboriginal and Torres Strait Islander community members as follows:

- Two (2) Elected Members and Two (2) Proxy Elected Members;
- One representative from each of the following families and one proxy representative:
  - Ryder
  - Garlett
  - Stack
  - Slater
  - McGuire
  - Kickett
  - Moody
  - Davis
- Two other Aboriginal and/or Torres Strait Islander Community Representatives
- ~~Shire of Northam CEO or nominated Executive Manager~~
- Member for Central Wheatbelt, State Legislative Assembly by invitation. They do not have voting rights
- Member of the WA Police Force by invitation. They do not have voting rights
- The CEO and or their nominee is to attend all meetings to provide advice and guidance to the committee. They do not have voting rights on the committee
- The local government shall provide secretarial and administrative support to the committee.

COMMS-TR-02 Nyoongar Cultural Advisory Group Terms of Reference 2021 - 2023\_V3 - Copy  
COMMS-TR-02 Nyoongar Cultural Advisory Group Terms of Reference 2021 - 2023\_V3

Nyoongar Cultural Advisory Group Committee Minutes  
04 May 2022

*Nyoongar Cultural Advisory Group Terms of Reference 2021 to 2023*

#### 4. Meetings

The NCAG shall meet at least four times annually.

Additional meetings shall be convened at the discretion of the presiding member.

#### 5. Reporting

Minutes and recommendations of each NCAG meeting shall be presented to the next Ordinary Meeting of the Council.

The NCAG is responsible for liaising with all relevant business units to complete and submit the RAP Impact Measurement Questionnaire to Reconciliation Australia annually.

#### 6. Duties and Responsibilities

The following activities will be carried out by the NCAG:

- Provide guidance and assistance to Council on the future development of the BKB.
- Provide input and advice in relation to the development of a Shire of Northam Reconciliation Action Plan.
- Meet with the Full Shire of Northam Council, not less than once each year to discuss progress of the Reconciliation Action Plan and BKB
- Develop a RAP within the context of the Shire of Northam's core business and in-line with:
  - Over-arching community strategic plan and corporate business plan.
  - Any existing Aboriginal and Torres Strait Islander employment strategy
  - Any existing supplier diversity strategy
  - Any existing equity and diversity policies.
- Establish a collaborative/consultative process for engaging staff across the organisation so that they can provide ideas for the RAP and comment on drafts.
- Develop a project plan and timeline to development, launch and begin implementing the RAP, including consultation with Reconciliation Australia at regular intervals.
- Regularly liaise with relevant business units and key stakeholders to review progress of RAP actions and:
  - Report RAP progress to internal and external stakeholders, including Reconciliation Australia, Shire of Northam elected members and staff, and Aboriginal and Torres Strait Islander stakeholders
  - Reflect on key learnings in the development of new RAPs.
  - Consider RAP implementation issues and consult with relevant business units to find solutions.
- Develop a new RAP when the current plan expires.

[COMMS-TR-02 Nyoongar Cultural Advisory Group Terms of Reference 2021 - 2023\\_V3 - Copy](#)  
[COMMS-TR-02 Nyoongar Cultural Advisory Group Terms of Reference 2021 - 2023\\_V3](#)

Nyoongar Cultural Advisory Group Committee Minutes  
04 May 2022



**8. URGENT BUSINESS APPROVED BY DECISION**

Cr Michael Ryan invited the Committee to raise items they would like to see included in the agenda for the next meeting.

Ms Elizabeth Stack requested that tracks and trails be discussed again.

Ms Donna Moody requested that the CEO provide other options for the structure of the committee that would allow for sitting fee payment.

Mrs Yvonne Kickett requested that NAIDOC Week event planning be included.

Cr Attila Menoshelyi requested the meeting dates be changed from first Wednesday of the month, as this clashes with another meeting he and other committee members are involved in.

**9. DATE OF NEXT MEETING**

To be advised.

**10. DECLARATION OF CLOSURE**

There being no further business, the Presiding Member Cr Michael Ryan declared the meeting closed at 5:20pm.

"I certify that the Minutes of the Nyoongar Cultural Advisory Group Committee held on Wednesday, 4 May have been confirmed as a true and correct record."

\_\_\_\_\_ Presiding Member

\_\_\_\_\_ Date

## 13. OFFICER REPORTS

### 13.1 CEO'S Office

#### 13.1.1 Lease Agreement for Northam Pistol Club, Portion of Reserve 3303, 98 Clarke Street Northam

<b>File Reference:</b>	A15653
<b>Reporting Officer:</b>	Alysha McCall, Acting Governance Coordinator
<b>Responsible Officer:</b>	Jason Whiteaker, Chief Executive Officer
<b>Officer Declaration of Interest:</b>	Nil
<b>Voting Requirement:</b>	Simple Majority
<b>Press release to be issued:</b>	No

#### BRIEF

For Council to approve a lease for a portion of Reserve 3303, 98 Clarke Street Northam to the Northam Pistol Club Inc.

#### ATTACHMENTS

Attachment 1: Map of Area.

---

#### A. BACKGROUND / DETAILS

The existing lease agreement expired on 30 June 2022 and is due for renewal.

The Northam Pistol Club is an active group which holds regular meets and tournaments.

#### B. CONSIDERATIONS

##### **B.1 Strategic Community / Corporate Business Plan**

Outcome 3: A happy, healthy, and connected community.

Objective 3.2: Grow participation in sport, recreation and leisure activities with quality regional facilities.

##### **B.2 Financial / Resource Implications**

Nil.

##### **B.3 Legislative Compliance**

Local Government Act 1995

Section 3.58 of the *Local Government Act 1995* details the requirements for the disposing of property.

*Local Government (Functions and General)*

Regulation 30 of the *Local Government (Functions and General) Regulations 1996* details dispositions of property which are excluded from the Act. As this disposal relates to recreational and sporting purposes it is exempt from section 3.58 of the Act.

*Land Administration Act 1997*

As the proposed lease is on a Reserve, in accordance with section 18 of the Land Administration Act 1997 approval from the Minister for Lands is required.

## **B.4 Policy Implications**

### A 8.5 Management of Council Property Leases

#### 2.0 Community Based Not-for-profit Lease: Reg 30(2)(b)

The basic principles considered in establishing a standard lease fee reflects a fair and equitable contribution of provision of a facility, the venue's pattern of use, location and the potential to obtain Community Grants assistance, as follows:-

- 2.1 The Shire levy an annual administration rent equivalent to the cost of building insurance, to all community, sport and recreation groups, not including the abovementioned Community Halls, and is reviewed annually.
- 2.2 Lessees or Licensees will be responsible for the full cost of the lease document preparation, registration and other costs associated with the execution of the agreement.
- 2.3 Lessees or Licensees must agree with Council to manage the "Demised Premises" on behalf of the community and to offer a service to the community that provides a net benefit.
- 2.4 The Lessee or Licensee will be responsible for the payment of outgoings, operating costs, and minor maintenance obligations.
- 2.5 The Lessee or Licensee will not be responsible for Shire land rates, but will be responsible for rubbish service rates.
- 2.6 The Shire will insure the "Demised Premises" at replacement value and pass on the cost to the Lessee as per 2.1. The Shire will perform any structural repairs, improvements and maintenance in accordance with levels determined within its budget forecast.
- 2.7 In the case of the Lessee or Licensee who leases a Council building and obtains approval to carry out extensions, alterations and/or additions, Council will insure the improvements as part of its insurance portfolio at replacement value.
- 2.8 The Lessee or Licensee will be responsible for contents insurance for their contents, and also hold public liability for their activities and



- workers compensation insurance for their employees (if applicable) to the value stipulated in the agreement.
- 2.9 The Lessee or Licensee will be responsible for the cost of repair of any internal damage, vandalism, corrective maintenance or damage to external doors, glass windows, security lighting and any other external facility through misuse by a club representative, member or guest. The Shire may carry out any corrective works and recoup the full cost from the Lessee.
  - 2.10 The Lessee or Licensee will be responsible for keeping the building clean and tidy at levels predetermined within the agreement.
  - 2.11 The Lessee or Licensee will not incur any costs for property damage excluding contents occasioned by fire, fusion, explosion, lightning, civil commotion, storm, tempest, or earthquake.
  - 2.12 On an annual basis, Lessees and Shire representatives will meet to carry out a property inspection to determine the extent to which the Lessee or Licensee have met their lease/licence obligation and to consider any specified building maintenance schedules for the following twelve month period within the Shire's budget parameters.

#### Delegated Authority Register

Delegation F06 allows for the disposal of property by lease or licence. As the leased area is greater than 1,000m<sup>2</sup> this lease cannot be approved under delegated authority.

### **B.5 Stakeholder Engagement / Consultation**

The Northam Pistol Club have confirmed that they wish to renew the lease.

### **B.6 Risk Implications**

<b>Risk Category</b>	<b>Description</b>	<b>Rating (likelihood x consequence)</b>	<b>Mitigation Action</b>
Financial	Nil.		
Health & Safety	Nil.		
Reputation	Nil.		
Service Interruption	Nil.		
Compliance	Nil.		
Property	Nil.		
Environment	Nil.		

### **B.7 Natural Environment Considerations**

Nil.

### C. OFFICER'S COMMENT

Officers have recently been made aware of unauthorised building works on the Reserve and are currently working with the Northam Pistol Club to obtain relevant approvals.

#### RECOMMENDATION / COUNCIL DECISION

**Minute No: C.4535**

**Moved: Cr Ryan**

**Seconded: Cr Mencshelyi**

**That Council:**

1. Lease a portion of Reserve 3303, 98 Clarke Street, Northam to the Northam Pistol Club Inc. for a period of five (5) years in accordance with section 2.0 of Council Policy A 8.5 Management of Council Property Leases and subject to:
  - a. Section 18 approval under the *Land Administration Act 1997* being provided by the Minister for Planning, Lands and Heritage.

**CARRIED 10/0**

Attachment 1



## 13.2 ENGINEERING SERVICES

### 13.2.2 RFQ 10 of 2022 Spencers Brook Road Spray Seal & Asphalt Works

<b>File Reference:</b>	8.2.9.1
<b>Reporting Officer:</b>	Scott Patterson, Executive Manager Engineering Services
<b>Responsible Officer:</b>	Scott Patterson, Executive Manager Engineering Services
<b>Officer Declaration of Interest:</b>	Nil
<b>Voting Requirement:</b>	Simple Majority
<b>Press release to be issued:</b>	No

#### BRIEF

For Council to consider submissions received in response to the Request for Quote (RFQ) 10 of 2022 – Spencers Brook Road Spray Seal & Asphalt Works. This report provides details of the submissions received and identifies a recommended contractor to complete the works.

#### ATTACHMENTS

Attachment 1: Evaluation report (Provided as a separate confidential attachment).

#### A. BACKGROUND / DETAILS

Spencers Brook Road project is a fully funded project under the Regional Road Safety Program endorsed by Council as a part of the 2021/2022 financial year's budget.

In compliance with legislative requirements, a request for these works was prepared and advertised on Tuesday 05 July 2022 to Friday 15 July 2022 in order to seek suitably qualified contractors to complete the works on the Shire's behalf.

#### B. CONSIDERATIONS

##### B.1 Strategic Community / Corporate Business Plan

Theme Area: Place

Outcome 9: Safe roads and greater use of sustainable transport options

Objective 9.1: Maintain a safe, efficient road network and supporting infrastructure.

## **B.2 Financial / Resource Implications**

The 2021/22 adopted budget made the following budget provisions for these projects:

Job 3680 Spencers Brook Road SLK 0.00-23.63 \$1,413,692 ex GST

The Spencers Brook Road project consists of three main components of work, being:

1. Road shoulder reconstruction
2. Spray seal/asphalt works
3. Line marking

Road shoulder reconstruction has already been awarded by council at a cost of \$851,583.88 ex. GST (RFQ 03/2022).

With a value of work of \$318,926.62 ex GST being recommended for award under this contract, this will leave \$243,181.50 for the line marking component of works. The line marking component being estimated at around \$250,000-\$300,000 to complete.

## **B.3 Legislative Compliance**

Section 3.57 of the Local Government Act 1995 requires a local government to invite tenders before it enters into a contract of a prescribed kind under which another person is to supply goods and services.

The Local Government (Functions & General) Regulations 1996 prescribe the manner in which Tenders are to be called and assessed.

The Local Government (Functions & General) Regulations 1996 additionally prescribes that tenders do not have to be publicly invited according to the requirements if the supply of the goods or services is to be obtained through the WALGA Preferred Supplier Program.

## **B.4 Policy Implications**

Policy F 4.2 – Purchasing and Tendering Policy.

## **B.5 Stakeholder Engagement / Consultation**

These are planned capital works projects. The stakeholders will be notified of the proposed work under contract via works notification.

### B.6 Risk Implications

Risk Category	Description	Rating (likelihood x consequence)	Mitigation Action
Financial	Cost of works exceed budget allowance.	Unlikely (2) x Medium (3) = Moderate (6)	Contract will be monitored closely. Cost variation to be rejected or adjusted as necessary.
Health & Safety	Medical type injury	Unlikely (2) x Medium (3) = Moderate (6)	Compliance to OHS & E policy and standard procedures as part of contract.
Reputation	Customer complaints	Unlikely (2) x Medium (3) = Moderate (6)	Complaints management protocol for swift resolution under contract, and ongoing works supervision.
Service Interruption	Delay in project delivery	Unlikely (2) x Medium (3) = Moderate (6)	Works programme will be monitored and followed as a part of contract
Compliance	Substandard work	Unlikely (2) x Minor (2) = Low (4)	Quality assurance standards to be complied as part of contract
Property	Nil	-	-
Environment	Nil	-	-

### C. OFFICER'S COMMENT

In response to the advertised request, three (3) submissions were received, of which all were compliant:

1. Fulton Hogan Industries Pty Ltd
2. KEE Surfacing Pty Ltd
3. Supercivil Pty Ltd

A full report on the procurement process and outcomes have been provided as a separate confidential attachment.

#### **RECOMMENDATION / COUNCIL DECISION**

**Minute No: C.4536**

**Moved: Cr Tinetti**

**Seconded: Cr Ryan**

**That Council:**

1. **Award Request for Quote 10 of 2022 – Spencers Brook Road Spray Seal and Asphalt Works for \$318,926.62(ex GST) to Fulton Hogan Industries Pty Ltd.**
2. **Authorise the Chief Executive Officer to make minor variations (maximum increase of 5%) to the awarded price prior to entering a contract with Fulton Hogan Industries Pty Ltd.**

**CARRIED10/0**

### 13.3 DEVELOPMENT SERVICES

*Cr M I Girak declared a "Proximity" interest in item 13.3.2 – Proposed Review of the Heritage List as Cr Girak's residential property is on the proposed Heritage List.*

*Cr A J Mencshelyi declared a "Impartiality" interest in item 13.3.2 – Proposed Review of the Heritage List as Some owners of properties on the Heritage List are known to Cr Mencshelyi. Including Cr Girak, who is seeking a decision in reference to Lot 5.*

*Cr R W Tinetti declared a "Impartiality" interest in item 13.3.2 – Proposed Review of the Heritage List as some property owners on the proposed Heritage List are known to Cr Tinetti.*

*Cr M P Ryan declared a "Impartiality" interest in item 13.3.2 – Proposed Review of the Heritage List as one of the property owners on the proposed Heritage List are known to Cr Ryan.*

*Cr D A Hughes declared a "Impartiality" interest in item 13.3.2 – Proposed Review of the Heritage List as Cr Girak and the owner of the Northam Tavern are known to Cr Hughes.*

*Cr J E G Williams declared a "Impartiality" interest in item 13.3.2 – Proposed Review of the Heritage List as some property owners on the proposed Heritage List are known to Cr Williams. One of the homes proposed to be included is a fellow councillor. She is requesting her home not be included*

*Cr C R Antonio declared a "Impartiality" interest in item 13.3.2 – Proposed Review of the Heritage List as some property owners on the proposed Heritage List are known to Cr Antonio. Including Cr Girak, a fellow councillor who is requesting changes to officer recommendation.*

*Cr P T Curtis declared a "Impartiality" interest in item 13.3.2 – Proposed Review of the Heritage List as Cr Girak is known to Cr Curtis.*

*Cr H J Appleton declared a "Impartiality" interest in item 13.3.2 – Proposed Review of the Heritage List as property owners on the list are known to Cr Appleton.*

*Cr D J Galloway declared a "Impartiality" interest in item 13.3.2 – Proposed Review of the Heritage List as Cr Girak is known to Cr Galloway as another councillor.*



Cr M I Girak left the meeting at 5:54pm

### 13.3.2 Proposed Review of the Heritage List

<b>Address:</b>	Various
<b>Owner:</b>	Various
<b>Applicant:</b>	Shire of Northam
<b>File Reference:</b>	3.1.8.19
<b>Reporting Officer:</b>	Jacky Jurmann, Manager Planning & Environment
<b>Responsible Officer:</b>	Chadd Hunt, Executive Manager Development Services
<b>Officer Declaration of Interest:</b>	Nil
<b>Voting Requirement:</b>	Simple
<b>Press release to be issued:</b>	No

#### BRIEF

Council at its Ordinary Meeting held on 18 May 2022 resolved to adopt the draft amended Heritage List for advertising purposes.

The advertising has been completed and four submissions were received. The issues raised in the submissions have been considered and the draft amended Heritage List is now presented to Council for adoption.

#### ATTACHMENTS

- Attachment 1: Draft Amended Heritage List.
- Attachment 2: Updated Place Records.
- Attachment 3: Schedule of Submissions.

---

#### A. BACKGROUND / DETAILS

As indicated in the previous Report on this matter, it is proposed to include an additional 27 places on the Shire's Heritage List to recognise their importance and provide an adequate level of protection.

These places were identified as part of a minor review of the Heritage List and new or amended place record forms have been created for each property providing justification for their inclusion, including information on their background and significance.

#### B. CONSIDERATIONS

### **B.1 Strategic Community / Corporate Business Plan**

Theme Area: Environment & Heritage

Outcome: The Shire of Northam honours, and is recognised for, its unique heritage and cultural identity.

Objective: The Shire of Northam is a destination for heritage tourism and heritage buildings are easily located and interpreted;  
The Shire of Northam's heritage buildings and locations are well maintained.

### **B.2 Financial / Resource Implications**

The review of the Heritage List is within current budget.

### **B.3 Legislative Compliance**

*Planning and Development (Local Planning Schemes) Regulations 2015*

Clause 8(1)(3) of Part 3 of Schedule 2 of the Regulations (also known as the Deemed Provisions) sets out the consultation requirements for entering or removing a place from the heritage list, or modifying the heritage list, and includes notifying each owner and occupier of the place to provide a minimum of 21 days to comment. Following adoption of the list (and any subsequent modifications), the Shire must notify the Heritage Council of WA, and each owner and occupier.

### **B.4 Policy Implications**

The inclusion of the subject places on the Heritage List will provide an appropriate level of statutory protection.

### **B.5 Stakeholder Engagement / Consultation**

Consultation was conducted in accordance with the provisions of the Regulations (as outlined above) for a minimum period of 21 days to all landowners and occupiers. The draft amended Heritage List was also advertised to the community on the Shire's website and social media.

Four (4) submissions were received in response and the issues raised in the submissions were considered in the finalisation of the proposed amendments. Refer to the Schedule of Submissions for details.

### **B.6 Risk Implications**

<b>Risk Category</b>	<b>Description</b>	<b>Rating (likelihood x consequence)</b>	<b>Mitigation Action</b>
Financial	Nil	Nil	Nil
Health & Safety	Nil	Nil	Nil
Reputation	Nil	Nil	Nil

Service Interruption	Nil	Nil	Nil
Compliance	Comply with requirements of Regulations.	Insignificant (1) x Unlikely (2) = Low (2)	Ensure compliance, particularly during consultation.
Property	Nil	Nil	Nil
Environment	Nil	Nil	Nil

### **B.7 Natural Environment Considerations**

Nil.

### **C. OFFICER'S COMMENT**

As outlined in the Schedule of Submissions, the contents of the submissions were considered by the Shire's Heritage Consultant and where appropriate modifications have been made to the Place Records, and if necessary, the draft amended Heritage List.

Following adoption of the amended list, the State Heritage Office's database Inherit will be updated to reflect the changes and the affected landowners will be advised.

The next stage in the Shire's review of its management of local heritage places is the creation of a strategic framework. This work has been funded by a grant from the Heritage Council, and in conjunction with the Shire's Heritage Consultant, a staged review of the Local Heritage Survey (formerly known as the Municipal Heritage Inventory) will be conducted. This review will inform any subsequent amendments to the Heritage List.

Extensive community consultation will be conducted as part of this project to ensure that all places of heritage significance are recognised and afforded the appropriate level of protection.

### **RECOMMENDATION**

#### **That Council:**

- 1. Adopt the draft amended Heritage List; and**
- 2. Notify all affected land owners and occupiers and the State Heritage Council of the amendments to the Heritage List.**

### **MOTION / COUNCIL DECISION**

**Minute No: C.4537**

**Moved: Cr Ryan**  
**Seconded: Cr Hughes**

**That Council:**

- 1. Adopt the draft amended Heritage List, subject to the following adjustment:**
  - Amend item 75 on the list by removing reference to lot 5 Gordon Street, Northam.**
- 2. Notify all affected land owners and occupiers and the State Heritage Council of the amendments to the Heritage List.**

**CARRIED 8/1**

REASON FOR CHANGE TO OFFICER RECOMMENDATION:

The Council formed the view that there were no buildings of historical value on Lot 5 Gordon Street, Northam.

Cr Girak returned to the meeting at 6:09pm

**Attachment 1: Draft Amended Heritage List**

**SHIRE OF NORTHAM  
LOCAL PLANNING SCHEME NO. 6  
REGISTER 1 – HERITAGE LIST**

## 1. INTRODUCTION

The provisions for the adoption of a Heritage List under the provisions of the Northam Local Planning Scheme No. 5 are outlined in Schedule 2 of the *Planning and Development (Local Planning Schemes) Regulations 2015* known as the Deemed Provisions.

*Note: Deemed provisions are those provisions that are automatically incorporated into a local planning scheme.*

## 2. SCHEME PROVISIONS UNDER SHIRE OF NORTHAM LOCAL PLANNING SCHEME NO. 6

The provisions state:

### 8. Heritage list

- (1) The local government must establish and maintain a heritage list to identify places within the Scheme area that are of cultural heritage significance and worthy of built heritage conservation.
- (2) The heritage list —
  - (a) must set out a description of each place and the reason for its entry in the heritage list; and
  - (b) must be available, with the Scheme documents, for public inspection during business hours at the offices of the local government; and
  - (c) may be published on the website of the local government.
- (3) The local government must not enter a place in, or remove a place from, the heritage list or modify the entry of a place in the heritage list unless the local government —
  - (a) notifies in writing each owner and occupier of the place and provides each of them with a description of the place and the reasons for the proposed entry; and
  - (b) invites each owner and occupier to make submissions on the proposal within 21 days of the day on which the notice is served or within a longer period specified in the notice; and
  - (c) carries out any other consultation the local government considers appropriate; and
  - (d) following any consultation and consideration of the submissions made on the proposal, resolves that the place be entered in the heritage list with or without modification, or that the place be removed from the heritage list.
- (4) If the local government enters a place in the heritage list or modifies an entry of a place in the heritage list the local government must give notice of the entry or modification to —
  - (a) the Heritage Council of Western Australia; and
  - (b) each owner and occupier of the place.

---

Shire of Northam – Heritage List

### 3. HERITAGE LIST REGISTER

The following is the Heritage List Register.

Heritage List #	Common Name	Lot No.	House No.	Street	Suburb	Assess. No	Management Category	MHI Ref.	Inherit Ref.	Reason for Entry
1.	Northam Fire Station (fmr #2) & Quarters	158	87	Duke Street	Northam	A10590	1	13	1852	As per <a href="#">SRHP Statement of Significance</a> .
2.	Uniting Church & Hall	611	103	Duke Street East	Northam	A14327	1	34	16300	As per <a href="#">SRHP Statement of Significance</a> .
3.	Colonial Tavern & Stables	8-10	197	Duke Street East	Northam	A14398	1	8	1855	As per <a href="#">SRHP Statement of Significance</a> .
4.	Bardeen Homestead Group	100, 104-105	866	Dumbarton Road	Irishtown	A425	1	3	3414	As per <a href="#">SRHP Statement of Significance</a> .
5.	Union Bank (ANZ Bank)	15-16	133	Fitzgerald Street	Northam	A11041	1	1	1861	As per <a href="#">SRHP Statement of Significance</a> .
6.	National Australia Bank	7	141	Fitzgerald Street	Northam	A11049	1	62	14788	As per <a href="#">SRHP Statement of Significance</a> .
7.	Bank of New South Wales (fmr)	113	161	Fitzgerald Street	Northam	A11060	1	36	1872	As per <a href="#">SRHP Statement of Significance</a> .
8.	Commonwealth Bank	111-112	181	Fitzgerald Street	Northam	A11079	1	9	1871	As per <a href="#">SRHP Statement of Significance</a> .
9.	Co-op (fmr) (Community Health Building)	14	222	Fitzgerald Street	Northam	A11115	1	10	10880	As per MHI Place Record.

Heritage List #	Common Name	Lot No.	House No.	Street	Suburb	Assess. No	Management Category	MHI Ref.	Inherit Ref.	Reason for Entry
10.	Northam Post Office & Quarters	1	239-243	Fitzgerald Street	Northam	A13258	1	24	1867	As per <a href="#">SRHP Statement of Significance</a> .
11.	Town Council Offices (fmr) & Library	17 & 18	298	Fitzgerald Street East (cnr Glebe St)	Northam	A11140	1	26	10907	As per <a href="#">SRHP Statement of Significance</a> .
12.	Northam Railway Station	359 & 370 (Reserve 31355)	401	Fitzgerald Street West	Northam	A11190	1	25	1859	As per <a href="#">SRHP Statement of Significance</a> .
13.	John Morrell's Grave	26637	-	Goomalling Road (cnr Gillett Rd)	Northam	A11264	1	17	1885	As per <a href="#">SRHP Statement of Significance</a> .
14.	Byfield House	1-3	30	Gordon Street	Northam	A14058	1	5	1878	As per <a href="#">SRHP Statement of Significance</a> .
15.	Uralia (Rosalyn, St John of God Hospital)	347	59	Gordon Street	Northam	A14343	1	35	1876	As per <a href="#">SRHP Statement of Significance</a> .
16.	Northam Army Camp	28465		Great Eastern Highway	Burlong	A496	1	68	6126	As per <a href="#">SRHP Statement of Significance</a> .
17.	The Residency (The Magistrate's Residence (fmr))	330	42	Habgood Street	Northam	A11407	1	31	1880	As per <a href="#">SRHP Statement of Significance</a> .
18.	Mitchell House (Bona Vista)	33	15-17	Hawes Street (cnr Duke St)	Northam	A13332	1	18	1882	As per <a href="#">SRHP Statement of Significance</a> .



Heritage List #	Common Name	Lot No.	House No.	Street	Suburb	Assess. No	Management Category	MHI Ref.	Inherit Ref.	Reason for Entry
19.	Buckland Homestead & Farm Buildings	60	972	Irishtown Road	Buckland	A15736	1	4	1843	As per <a href="#">SRHP Statement of Significance</a> .
20.	Morby Farm Cottage	600	70	Katrine Road	Katrine	A13075	1	19	1837	As per <a href="#">SRHP Statement of Significance</a> .
21.	Northam (Pioneer) Cemetery (1856+)	Avon Loc. 20511	160	Katrine Road	Northam	A14141	1	21	3976	As per <a href="#">SRHP Statement of Significance</a> .
22.	Northam Senior High School	463	30	Kennedy Street	Northam	A14136	1	66	1883	As per <a href="#">SRHP Statement of Significance</a> .
23.	Fermoy House (fmr), St Joseph's Primary School	236 & 60	1	Lance Street	Northam	A15718	1	47	1874	As per <a href="#">SRHP Statement of Significance</a> .
24.	Railway Goods Shed	438	437	Morrell Street	West Northam	A12015	1	15	17618	As per <a href="#">Updated Place Record</a> .
25.	Enfield House	1	12	Newcastle Road (Corner Enfield Terrace)	Northam	A12176	1	12	10882	As per <a href="#">Updated Place Record</a> .
26.	Curdnatta	32	22	Newcastle Road	Northam	A12187	1	11	10881	As per <a href="#">SRHP Statement of Significance</a> .
27.	St John's Anglican Church & Parish Hall	90	11	Wellington Street	Northam	A12502	1	33	1891	As per <a href="#">SRHP Statement of Significance</a> .
28.	Northam State School (fmr) (Avon	380	33	Wellington Street	Northam	A13095	1	29	1881	As per <a href="#">SRHP Statement of Significance</a> .

Heritage List #	Common Name	Lot No.	House No.	Street	Suburb	Assess. No	Management Category	MHI Ref.	Inherit Ref.	Reason for Entry
	Valley Arts Workshop)									
29.	Northam Post Office (fmr) (Avon Valley Arts Centre)	380	33	Wellington Street	Northam	A13095	1	29	1892 1867	As per <a href="#">SRHP Statement of Significance</a> .
30.	Northam Town Hall & Lesser Hall	86	85	Wellington Street (cnr Gordon Street)	Northam	A13409	1	27	1877	As per <a href="#">SRHP Statement of Significance</a> .
31.	Northam Police Station & Court House	429	114	Wellington Street	Northam	A14132	1	23	1890	As per <a href="#">SRHP Statement of Significance</a> .
32.	Northam Police Station (former)	254	128	Wellington Street (cnr Fitzgerald Street)	Northam	A12551	1	23	17372 & 1869	As per MHI Place Record.
33.	Railway Institute	453	182	Wellington Street	Northam	A12641	1	30	1898	As per MHI Place Record.
34.	Hoopers Winery & Surrounds (Keanes Vineyards)	5739	9	Yates Street	Bakers Hill	A2052	1	16	10917	As per <a href="#">SRHP Statement of Significance</a> .
35.	Chauncy's Cairn			North of Cobb Road, Chidlow State Forest	Woottatting		1	6	8565	As per <a href="#">SRHP Statement of Significance</a> .
36.	Clackline Bridge or Viaduct			Over Clackline Brook and Railway (500m east of Clackline townsite)	Clackline		1	7	10910	As per <a href="#">SRHP Statement of Significance</a> .

Heritage List #	Common Name	Lot No.	House No.	Street	Suburb	Assess. No	Management Category	MHI Ref.	Inherit Ref.	Reason for Entry
37.	Goldfields Water Supply			Mundaring to Kalgoorlie	Northam LGA		1	14	25251	As per <a href="#">SRHP Statement of Significance</a> .
38.	Methodist Manse (fmr)	62	100	Chidlow Street	Northam	A14199	2	59	24992	As per <a href="#">Updated MHI Place Record</a> .
39.	Jacaranda House	7-8	25	Duke Street	Northam	A10556	2	NEW	NEW	As per <a href="#">Place Record</a> .
40.	Northam Flour Mill	100 & 34	334	Fitzgerald Street East	Northam	A15569	2	64	10889	As MHI Place Record & <a href="#">SRHP Interim Assessment</a> .
41.	Grand Hotel (fmr)	146-147	426	Fitzgerald Street	Northam	A11194	2	51	1873	As per MHI Place Record.
42.	Quellington Hall	28631 (Reserve 3410)		Grass Valley South Road	Quellington	A995	2	72		As per MHI Place Record.
43.	Stackallan Homestead	9501	29	Henty Place	Northam	A15800	2	NEW	NEW	As per <a href="#">Place Record</a> .
44.	Katrine Precinct	50	1418	Katrine Road	Katrine	A1722	2	54	16758	As per MHI Place Record.
45.	Lockyers Mill, Hampton Vineyard	1	633	Katrine Road	Irishtown	A384	2	57	3413	As per MHI Place Record.
46.	Carami House	26	38	Newcastle Road	Northam	A12198	2	41	10879	As per <a href="#">Updated MHI Place Record</a> .
47.	Bakers Hill Railway Platform	254		Newman Street	Bakers Hill	A16442	2	NEW	NEW	As per <a href="#">Place Record</a> .
48.	St Peters Anglican Church	50	1277	Northam-Pithara Road	Jennapullin	A1643	2	78	1847	As per MHI Place Record.

Heritage List #	Common Name	Lot No.	House No.	Street	Suburb	Assess. No	Management Category	MHI Ref.	Inherit Ref.	Reason for Entry
49.	Egoline Homestead	100	439	Northam-Toodyay Road	Malabaine	A2050	2	46	3416	As per MHI Place Record.
50.	Glen Avon & Glen Avon Barn	204	1252	Northam-Toodyay Road	Katrine	A16114	2	32	3989	As per MHI Place Record.
51.	Warranine Homestead Group	75	91	Old Spencers Brook Road	Mokine	A1983	2	81	1886	As per MHI Place Record.
52.	Mokine Homestead	49	1662	Spencers Brook Road	Mokine	A15382	2	60	10919	As per MHI Place Record.
53.	Spencers Brook Tavern (fmr Brookton Hotel)	148	47	Thomas Street	Spencers Brook	A2725	2	74	1838	As per MHI Place Record.
54.	Bandon House	851	14	Wellington Street	Northam	A12499	2	NEW	NEW	As per <a href="#">Place Record</a> .
55.	Bushmans' House (fmr) (Northam Guest House/ Clearview House/ Temperance Hostel)	7	51	Wellington Street	Northam	A12507	2	41	1889	As per MHI Place Record.
56.	St Joseph's Catholic Church Group (Convent & School)	54	77	Wellington Street	Northam	A15185	2	76	1897	As per MHI Place Record.
57.	St James Anglican Church	97	185	Wellington Street (cnr Morrell St)	West Northam	A13532	2	75	1899	As per MHI Place Record.
58.	Dr Burrow's Wife's Grave			Mt Ommaney	Northam		2	45		As per MHI Place Record.

Heritage List #	Common Name	Lot No.	House No.	Street	Suburb	Assess. No	Management Category	MHI Ref.	Inherit Ref.	Reason for Entry
59.	St Simon & St Jude Anglican Church	157	34	Boronia Avenue (cnr Banksia Ave)	Wundowie	A1571	3	111	11646	As per MHI Place Record.
60.	Grass Valley Hotel (fmr Tavern)	4 & 132	8	Carter Street (cnr George Street)	Grass Valley	A1961	3	97	1846	As per MHI Place Record.
61.	Wundowie Foundry – Factory Office	28416	52	Hawke Avenue	Wundowie	A16025	3	113	10922	As per MHI Place Record.
62.	Pensioner Guard Cottage (fmr)	123	1	McMillan Place	Northam	A13174	3	106	2661	As per MHI Place Record.
63.	Exhibition Building & Commemorative Arch	217	44	Peel Terrace	Northam	A14137	3	91	18797	As per MHI Place Record.
64.	Northam Care & Share	401	88	Wellington Street	Northam	A12529	3	104	25048	As per <a href="#">Updated Place Record</a> .
65.	Our Lady Queen of Heaven Church	205	4	Zamia Terrace (Cnr Orchid Tce)	Wundowie	A1585	3	105	13106	As per MHI Place Record.
66.	Agricultural Hall	Avon Loc. 00440		Irishtown Rd	Irishtown	A385	2	37	1844	As per <a href="#">Updated Place Record</a> .
67.	Australasia Bank (fmr)	123	85	Fitzgerald St East	Northam	A11019	2	38	1858	As per <a href="#">Updated Place Record</a> .
68.	Cody House	120	77	Gordon St	Northam	A16213	2	42	1879	As per <a href="#">Updated Place Record</a> .
69.	Commercial Hotel (Hotel 190)	340	190	Fitzgerald St East	Northam	A13530	2	43	1864	As per <a href="#">Updated Place Record</a> .

Heritage List #	Common Name	Lot No.	House No.	Street	Suburb	Assess. No	Management Category	MHI Ref.	Inherit Ref.	Reason for Entry
70.	Dempster Homestead, Muresk Institute	12	1	Muresk Rd	Muresk	A2390	2	44	10914	As per Updated Place Record.
71.	Government Building	223	303	Fitzgerald St East	Northam	A11146	2	50	1875	As per Updated Place Record.
72.	Homeswest (fmr)	14	129	Fitzgerald St East	Northam	A11071	2	52	1870	As per Updated Place Record.
73.	Lands Office (fmr)	384	263	Fitzgerald St East	Northam	A11149	2	55	1866	As per Updated Place Record.
74.	Link Theatre	1-2	89	Duke St East	Northam	A10591	2	56	1854	As per Updated Place Record.
75.	Masonic Hall (fmr)	5-6	16	Gordon St	Northam	A15461	2	58	10890	As per Updated Place Record.
76.	Northam RSL Memorial Hall & Senior Citizens Centre	131	265	Fitzgerald St East	Northam	A11138	2	65	13503	As per Updated Place Record.
77.	Monument – Chidlow & Jones	5		Dr Dunlop Grove	Northam	A11237	2	61	1840	As per Updated Place Record.
78.	National Bank (fmr)	750	55	Fitzgerald St East	Northam	A13318	2	62	1858	As per Updated Place Record.
79.	The Northam Advertiser Officer (fmr)	600	245	Fitzgerald St East	Northam	A11126	2	63	1860	As per Updated Place Record.

Heritage List #	Common Name	Lot No.	House No.	Street	Suburb	Assess. No	Management Category	MHI Ref.	Inherit Ref.	Reason for Entry
80.	Northam Tavern	151	75	Fitzgerald St East	Northam	A11014	2	67	1862	As per Updated Place Record.
81.	G J Coles & Co. (fmr)	1	178	Fitzgerald St East	Northam	A11077	2	68	10886	As per Updated Place Record.
82.	Pine Park	16	61	Duke St	Northam	A10577	2	69	1853	As per Updated Place Record.
83.	Platelayers Cottage (fmr)	29575		Spencers Brook Rd (opp. 38 Rose Terrace)	Spencers Brook	A1474	2	70	16633	As per Updated Place Record.
84.	Poole St Bridge	505 / R46412		Poole St (spanning over Avon River)	Northam	A16360	1	28	3549	As per SRHP Statement of Significance.
85.	Prospect House	2	402	Fitzgerald St West	Northam	A11181	2	71	10908	As per Updated Place Record.
86.	RAAF Anson Aircraft Monument	28827 / R39847		Avro Anson Rd (adjacent No. 35)	Mokine	A1647	2	73	13509	As per Updated Place Record.
87.	Shamrock Hotel (Dome & Farmers Home Hotel)	800	112	Fitzgerald St West	Northam	A16102	1	32	1865	As per SRHP Statement of Significance.
88.	St Nicholas' Anglican Church	159	4605	Great Eastern Hwy	Bakers Hill	A1526	2	77	1842	As per Updated Place Record.
89.	The Riverside Hotel (Avon Bridge Hotel)	450	322	Fitzgerald St East	Northam	A11142	1	39	1863	As per Updated Place Record.
90.	Throssell Emporium (fmr)	3	11	Peel Terrace	Northam	A12434	2	79	10891	As per Updated Place Record.

Heritage List #	Common Name	Lot No.	House No.	Street	Suburb	Assess. No	Management Category	MHI Ref.	Inherit Ref.	Reason for Entry
91.	Throssell Fountain	500	1	May Park, May St	Northam	A16321	2	92	10883	As per Updated Place Record.

Register of Entries /Amendments



H List#	Date of Update	Date of Decision	File reference
1	August 2022		



**Attachment 2: Updated Place Records**

<b>Heritage Item #</b>		
MI Reference: 68 HCWA No: 10886	Place Name: G. J. Coles and Co., Limited (fmr)	Other Name/s: Norrish Realty Building, Northam Travel
		Date of Review: September 2021
		
Address: 178 Fitzgerald Street East, Northam	Lot No: 19 Property Key: Plan Diagram: 697 Vol Folio: 1822/59 Assess No: A11077	
Locality: Northam	GPS:	
Current Use: Unoccupied (front), WA Country Health Services (rear)	Original Use(s): Retail	
<b>HERITAGE LISTINGS</b>		
Listings: Art Deco Significant Building Survey, 1994		
<b>CONSTRUCTION</b>		
Date of Construction: 1937		
Architect / Builder: F. G. B. Hawkins and H. A. Norris		
Architectural Style: Inter-War Functionalist and Art Deco		
<b>PHYSICAL EVIDENCE</b>		
<p>Description:                      G. J. Coles and Co., Limited (fmr), located at 178 Fitzgerald Street East, is a single storey masonry building with a corrugated steel hip roof displaying characteristics of the Inter-War Functionalist and Art Deco styles of architecture.</p> <p>The building is located on a corner lot adjacent to the Avon Street Mall and town park area. The building has a rendered masonry parapet with detailed vertical pilasters. A curved cantilevered awning addresses the corner and features a stepped parapet with horizontal detailing and signage that reads 'Northam Travel and Cruise'. The underside of the awning is clad with pressed tin detailing.</p> <p>The ground floor is largely glazed with a fixed glass and brass framing. The corner has fixed faceted glazing. The glazing rests on a low plinth that is clad with blue ceramic tile. The entrance is through a set of aluminium framed glazed shop front doors addressing Fitzgerald Street East.</p>		

The building extends down along Avon Street Mall. The rear of the brick building is painted with a face brick base. The roof is clad with short sheet corrugated steel and features steel roof cowls. The building has been adapted with several large openings extending along the northern façade.
Condition: Good
<b>HISTORICAL</b>
Notes: <i>The following information includes extracts from the heritage assessment of 23-325 &amp; 16-334 Fitzgerald Street and 1-15 &amp; 12-18 Peel Terrace, Northam, prepared by Greenward Consulting, June 2015.</i>
The construction of these premises was announced in 1937 in the following extract from <i>The West Australian</i> (10 July 1937): <i>Work has begun on the erection of premises to cost £3,130, with an additional £2,400 for shop fronts and counters, for G. J. Coles and Co., Limited, at the corner of Fitzgerald and Avon streets, Northam. The site has a frontage of 43ft. 8in to the main street and a depth of 198ft to Avon-street. Modern display windows of curved glass on the front and for 20 feet down Avon street will be well sheltered from the heat by a 10ft. cantilever verandah with recessed blinds. Black and cream tiles will lead up to entrances of inlaid terrazzo floors and four plate glass doors. The counters are of a good modern design, being finished in walnut plywood and staybrite steel fitted with bag pockets, recesses and other fittings, for ease of working. A complete set of wall fittings has been designed in similar material to that of the counters. About £160 will be spent on the electrical work, with electric fans 20ft. apart. The whole of the building will be fire-proofed with special layers of heat-protecting material over the whole of the roof. The architects are Mr. F. G. B. Hawkins, in association with Mr. H. A. Norris, of Melbourne, and the successful contractor is H. Scholfield. The shop fronts and counters are being executed by Wunderlich, Ltd., and Arcus, Ltd., respectively.</i>
As of September 2021, the front building is unoccupied while the rear is occupied by the Government of Western Australia Country Health Services.
Theme: Commercial services and industries; Community services and utilities
Associations: G.J. Coles, F.G.B. Hawkins (Architect)
Heritage Assessment or Conservation Plan: Heritage Assessment of 23-325 & 16-334 Fitzgerald Street and 1-15 & 12-18 Peel Terrace, Northam. Prepared by Greenward Consulting, June 2015.
Public Access: No
<b>SIGNIFICANCE</b>
Level of Integrity: Medium
Level of Authenticity: High
Statement of Significance:
G. J. Coles and Co., Limited (fmr) is of cultural heritage significance for the following reasons: <ul style="list-style-type: none"> <li>The place is significant as a small scale simplistic version of an Inter-War Functionalist building highlighting the Art Deco features that positively contribute to the streetscape of the main commercial street of Northam.</li> </ul>
Level of Significance: Considerable
Heritage Category: 2

Additional Photographs	
	
East Corner Source: Municipal Heritage Inventory, 2012	Corner awning Source: Stephen Carrick Architects September 2021
	
Faceted glass corner Source: Stephen Carrick Architects September 2021	Pressed tin ceiling to awning Source: Stephen Carrick Architects September 2021
	
Tiles surrounding windows Source: Stephen Carrick Architects September 2021	Rear of building Source: Stephen Carrick Architects September 2021
	
Courtyard and park to the north Source: Stephen Carrick Architects September 2021	

**Heritage Item #**

MI Reference: 28 HCWA No: 3549	Place Name: Poole Street Bridge	Other Name/s: West Northam Footbridge
		Date of Review: October 2021



Address: Poole Street (spanning over Avon River), Northam	Lot No: Property Key: Plan Diagram: Vol Folio: Assess No: In front of A15190
Locality: Northam	GPS:
Current Use: Former Bridge	Original Use(s): Bridge
<b>HERITAGE LISTINGS</b>	
Listings: State Register of Heritage Places (1996) Statewide Large Timber Structures Survey (1998) Classified National Trust (1995)	
<b>CONSTRUCTION</b>	
Date of Construction: 1917	
Architect / Builder: P.V. O'Brien (Engineer)	
Architectural Style:	
<b>PHYSICAL EVIDENCE</b>	
Description: Poole Street Bridge is located at the northern end of Poole Street to the west of the Northam town centre. The footbridge crosses the Avon River and is approximately 150m long and 2m wide.  The structure consists of large timber piers supporting a system of timber bearers, joists and planks. The piers have diagonal cross bracing that is connected by large iron bolts. The walkway is enclosed by a rounded steel balustrade with a wire mesh infill. The bridge is in poor condition with several failed bearers to the southern end. Many timber planks have collapsed causing the bridge to be unusable. A Keep Out sign is located at each end.  Commemorative plaques and additional historical information are located at the southern end of the Bridge. The bridge is located along the Dornij Koorliny 'Walking Together' Track, which is a loop trail around Northam.	

<p>The bridge is at the eastern most end of the 70km long multi use 'Kep Track' from Mundaring Weir to Northam. In its inception the Track was designed to continue across the bridge and terminate at the old Northam Railway Station; however, lack of funding has prevented this from happening.</p>
<p>Condition: Poor</p>
<p><b>HISTORICAL</b></p>
<p><b>Notes:</b>                  The bridge was associated with the development of the Goldfields Water Supply (G.W.S.) Scheme and is representative of wooden bridges built by the PWD in the early twentieth century. It was built to carry the G.W.S. pipeline and to provide a footbridge for the townspeople of Northam. It was the only major river crossing bridge built for the Goldfields Water Supply Scheme, and is a rare example in Western Australia of a structure designed to be both a pipeline bridge and a footbridge, although it is no longer used for either.</p> <p>The bridge linked two sides of the river, providing easy access to the Northam Railway Station, West Northam, and the nearby shops, hotel, houses and the railway workshop. In summer, Northam children used the bridge for access to Burlong Pool, and in the 1950s the bridge was well used by the many European migrants who temporarily settled at the Holden Migrant Camp.</p> <p>The pipeline was shifted in 1958 to a new bridge in Burn Street. As of September 2021, the bridge is not in use and closed off to the public due to poor condition.</p>
<p>Theme: Community Services and Utilities</p>
<p>Associations: Water Corporation</p>
<p>Heritage Assessment or Conservation Plan:</p>
<p>Public Access: No</p>
<p><b>SIGNIFICANCE</b></p>
<p>Level of Integrity: High</p>
<p>Level of Authenticity: High</p>
<p>Statement of Significance:</p>
<p>Poole Street Bridge is of cultural heritage significance for the following reasons:</p> <ul style="list-style-type: none"> <li>• The place, in its tranquil setting of the Avon River at a point where the river is in a relatively natural state, has landmark value. The style of timber construction, its regularity and uniformity of timber piers and the line of its footway, is juxtaposed against the natural state of the river. The strong contrast between industrial structure and natural setting contributes to the landmark quality of the place.</li> <li>• The place is closely associated with the development of the Goldfields Water supply pipeline from Perth to Kalgoorlie in the first decades of the century.</li> <li>• The place is representative of the construction of the pipeline through Northam at a time when the town was experiencing growth to the east, and the consolidation of its importance as a major rural centre. It is associated with the growth in prosperity of the town and district of Northam.</li> <li>• The place is valued by the community as a visible reminder of the decades of use by the population of West Northam during Northam's period of growth in the first quarter of the century, and by many workers and children, including migrants stationed at the Holden Camp, in the 1950s.</li> <li>• The place is a rare structure in Western Australia. It is the only bridge built for the Goldfields Water Supply Scheme at a major river crossing which serves as both pipeline bridge and footbridge.</li> </ul>
<p>Level of Significance: Exceptional</p>
<p>Heritage Category: 1</p>

Additional Photographs	
	
<p>View from South end Source: Municipal Heritage Inventory 2012</p>	<p>South end Source: Stephen Carrick Architects October 2021</p>
	
<p>Damage to timber pillars Source: Stephen Carrick Architects October 2021</p>	<p>Historical plaque Source: Stephen Carrick Architects October 2021</p>

### Attachment 3: Schedule of Submissions

#### Draft Heritage List Amendments

#### Schedule of Submissions

No.	Name & Address	Submission	Heritage Consultant's Comments	Officer's Comments
1.	Randle Beavis (landowner) President, Grass Valley Progress Association	<p>I cannot find or recall any notification advising that our property was to be removed from the register as per the scheme provisions stated:</p> <ul style="list-style-type: none"> <li>Heritage List #17, MHI Ref 118, Inherit Ref 1848, Grass Valley Store (fmr), Assess No A246, Lot No. 11, 4 George St, Grass Valley.</li> </ul> <p>Monday 12/8/2019 I did advise planning that the current Grass Valley post office at Lot 8, 14 Carter St Grass Valley was erected in 1986 and therefore not really a heritage building.</p> <p>The former Post office at Lot 6, 10 Carter St Grass Valley should be included on the register in its place. No response was received on this advice however I note the 1986 post office is removed from the register.</p> <p>As President of the Grass Valley Progress Association, we have no record of notification that the following property was removed as well:</p> <ul style="list-style-type: none"> <li>Heritage List #4, MHI Ref 96, Inherit Ref the, Grass Valley Railway goods shed (fmr) Carter St Grass Valley, this is the only remaining building from the former Grass Valley railway station, was built prior to 1900 and should be included.</li> </ul> <p>Also note that the Grass Valley Hall opened by the Premier of WA in August 1921 is not listed. It is listed on the Heritage Council of WA as place number 01845.</p> <p>These places are noted in Shires approved Grass Valley Community Plan under item 2.4.9 History &amp; Culture.</p> <p>Heritage List #6, MHI Ref 114, Inherit Ref 10912, Clackline Refractory (fmr), Assess No A526, Lot No 19, House No 3 Clackline Road Clackline seems to be removed too.</p>	<p>We are unsure of the broader context for the response from Mr Beavis. We have identified below the information that we are aware of with regard to the six places raised in the submission. We would recommend that when further LHS review work is undertaken that a meeting is held with Mr Beavis to discuss these places as well as other places for further consideration for the LHS.</p> <p>Correspondence should be sent to Mr Beavis outlining the process going forward.</p> <ol style="list-style-type: none"> <li>Grass Valley Store</li> </ol> <p>MHI place record form appears to have little to no information and has been allocated a Management Category 4. It is recommended that further review of the place and Management Category should be undertaken as part of the next update of the Local Heritage Survey.</p> <ol style="list-style-type: none"> <li>Grass Valley Post Office Former</li> </ol> <p>MHI identifies the place as the 1986 tin shed. In 2019 the place was reviewed with additional information added. The place remains a Management Category 3. It is recommended that the place be further reviewed as part of the next update of the Local Heritage Survey.</p> <ol style="list-style-type: none"> <li>Grass Valley Railway Goods Shed</li> </ol> <p>MHI identified the place with a Management Category 3.</p> <ol style="list-style-type: none"> <li>Grass Valley Hall</li> </ol> <p>The place has not been included in any previous MHI. It is recommended that the place should be submitted for consideration during the next update of the Local Heritage Survey</p> <ol style="list-style-type: none"> <li>Clackline Refractory (fmr)</li> </ol> <p>MHI identified the place with a Management Category 4. The Shire of Northam Heritage List has been amended to only include places with Management Category 1 and 2. It is recommended that the place be further reviewed as part of the next update of the Local Heritage Survey.</p> <ol style="list-style-type: none"> <li>House No 3 Clackline Road, Clackline</li> </ol> <p>Could not locate any information for this place.</p>	<p>The Grass Valley properties listed in the submission are Category 3 properties on the Local Heritage Survey (formerly known as the Municipal Heritage Inventory) and were originally proposed for inclusion on the draft Heritage List (2020), which was based on a draft list compiled by a former heritage consultant a few years earlier.</p> <p>However, a review of the places by the Shire's current Heritage Consultant advised that the Heritage List should only include places listed in Categories 1 and 2 and that a review of the LHS should be conducted to determine the correctness of the categories and whether any new places should be identified and included.</p> <p>The review of the LHS is being conducted as part of the Shire's grant project to establish a strategic framework for heritage protection and further community consultation will occur as part of this process.</p>
2.	Daniel Stevens, Senior Planner Water Corporation	<p>Thanks for the opportunity to comment on the proposed inclusion of the Water Corporation's property at 263 Fitzgerald St East, Northam in the Shire's local heritage list. Water Corporation has no objection to the proposal.</p>	<p>Noted and no further comment.</p>	<p>Noted.</p>

3.	Julian Donaldson, CEO National Trust WA	<p>Thank you for advising us of the revisions to the LPS6 – Heritage List.</p> <p>The National Trust has a Management Order over the Poole Street Bridge which is a part of the Trust's Golden Pipeline Heritage Trail. The Bridge is listed on the State Register of Heritage Places and included on the Shire's Heritage List.</p> <p>The National Trust is comfortable with the proposed changes to the listing. We suggest one small addition at the end of the 'Physical Evidence' section:</p> <p>"The bridge is at the eastern most end of the 70km long multi use 'Keap Track' from Mundaring Weir to Northam. In its inception the Track was designed to continue across the bridge and terminate at the old Northam railway station however lack of funding has prevented this from happening."</p>	Place Record Form has been amended as per comments.	Agree. Place record to be amended.
4.	Maria Girak (landowner) 16 Gordon Street, Northam	<p>I refer to the Shire of Northam Public Notice, 24 May 2022. Proposed Amendments to the Heritage List. My residential property, the former Masonic Hall "Stone Court" at 16 Gordon Street, Northam has been listed on the Proposed Amended Heritage List #75.</p> <p>Assess No: A15461 M Reference: 58 HCWA No: 10890</p> <p>The property at 16 Gordon Street, Northam WA 6401 is on two separate titles, Lot 5 and Lot 6 on Plan 647 Vol Folio: 1498/380.</p> <p>The building subjected to the Heritage listing is situated on Lot 6 of the Certificate of Title</p> <p>I welcome the consideration of placing the former Masonic Hall building located on Lot 6 under heritage protection, and I have no objection for the building to be added to the register.</p> <p>However, Lot 5 is an unimproved block, and has no heritage significance. I do not consent to Lot 5 being added to the Heritage Register. I request that the Shire of Northam remove reference to Lot 5 on Plan 647 Vol Folio: 1498/380, 16 Gordon Street, Northam WA from the Shire of Northam Heritage List Register, and every other document and record relevant to heritage listing.</p>	We have reviewed the curtilage for 16 Gordon Street, Northam. In our opinion both Lots 5 and 6 should be included in the listing in the Local Heritage Survey. Any future development to the property will need to be cognisant of the cultural heritage values of the place.	Agree. Aerial photographs indicate that a portion of the building encroaches onto Lot 5 together with a rear addition and stone fencing. It is therefore appropriate that both lots are included on the listing.
5.	Les Norrish (landowner) 178 Fitzgerald Street, Northam	<p>Our building situated at 178 Fitzgerald St Northam is currently noted on the Shire records as "Northam Travel".</p> <p>We would like to name the building something more appropriate – like say, Coles Corner or G J Coles – the original Tenants.</p> <p>We will make enquires with the appropriate parties. Any views you have to improve the historic character of this building would be appreciated.</p>	<p>Agree with a proposed name amendment.</p> <p>Suggest liaison with Mr Norrish with regard to the name change to G. J. Coles and Co., Limited (fmr).</p> <p>Northam Travel to be included under other names.</p> <p>Place Record Form has been amended to reflect this change.</p>	Agree. Place record to be amended.



## 13.4 CORPORATE SERVICES

### 13.4.1 Accounts & Statements of Accounts 1 July 2022 to 31 July 2022

<b>File Reference:</b>	2.1.3.4
<b>Reporting Officer:</b>	Louise Harris, Creditors Officer
<b>Responsible Officer:</b>	Colin Young, Executive Manager Corporate Service
<b>Officer Declaration of Interest:</b>	Nil
<b>Voting Requirement:</b>	Simple Majority
<b>Press release to be issued:</b>	No

#### BRIEF

For Council to receive the accounts for the period from 1 July 2022 to 31 July 2022.

#### ATTACHMENTS

Attachment 1: Accounts & Statements of Accounts – July 2022.  
Attachment 2: Declaration.

---

#### A. BACKGROUND / DETAILS

The reporting of monthly financial information is a requirement under section 6.4 of the Local Government Act 1995, and Regulation 34 of the Local Government (Financial Management) Regulations.

Pursuant to Financial Management Regulation 13, a list of payments made from Municipal and Trust accounts is required to be presented to Council on a periodical basis. These details are included as Attachment 1. In accordance with Financial Management Regulation 12, the Chief Executive Officer has delegated authority to make these payments.

#### B. CONSIDERATIONS

##### B.1 Strategic Community / Corporate Business Plan

Theme Area 6: Governance & Leadership.

Outcome 6.3: The Shire of Northam council is a sustainable, responsive, innovative and transparent organisation.

##### B.2 Financial / Resource Implications

Payments of accounts are in accordance with Council's 2022/23 Budget.

**B.3 Legislative Compliance**

Section 6.4 & 6.26(2) (g) of the Local Government Act 1995.  
 Financial Management Regulations 2007, Regulation 12 & 13.

**B.4 Policy Implications**

Nil.

**B.5 Stakeholder Engagement / Consultation**

Not applicable.

**B.6 Risk Implications**

<b>Risk Category</b>	<b>Description</b>	<b>Rating (consequence x likelihood)</b>	<b>Mitigation Action</b>
Financial	Figures not reflecting the true financial situation	Rare (2) x Medium (3) = Low (3)	There are processes in place to show compliance with relevant legislation
Health & Safety	N/A	N/A	N/A
Reputation	N/A	N/A	N/A
Service Interruption	N/A	N/A	N/A
Compliance	Report not being accepted by Council	Rare (2) x Medium (3) = Low (3)	There are processes in place to show compliance with relevant legislation
Property	N/A	N/A	N/A
Environment	N/A	N/A	N/A

**B.7 Natural Environment Considerations**

Nil.

**C. OFFICER'S COMMENT**

The matter of Council 'supporting local business' has been raised over a long period. To assist in providing a greater understanding of the purchasing patterns of the Shire of Northam, the following graph summarises the payments made locally for the month of July 2022:

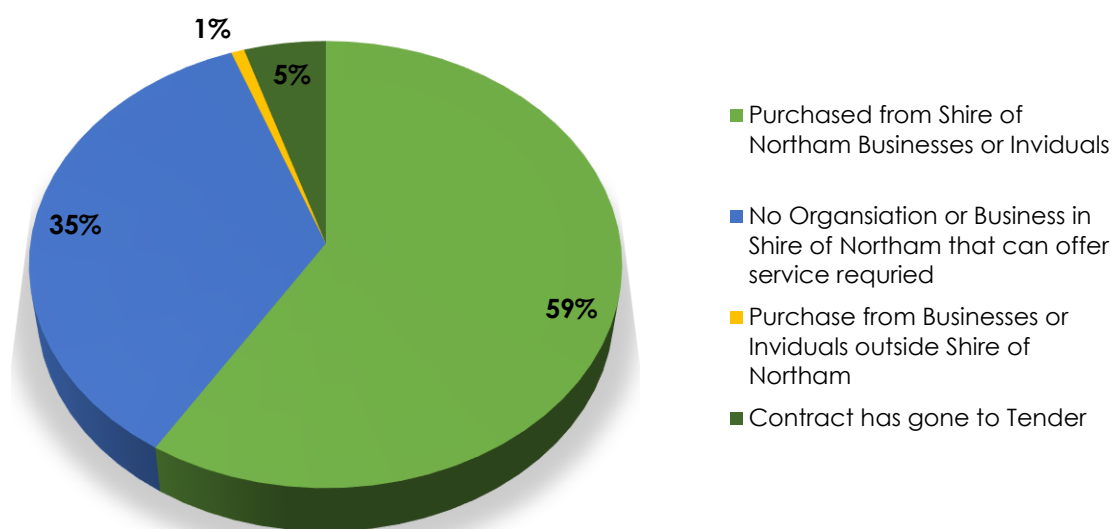

**RECOMMENDATION / COUNCIL DECISION**

**Minute No: C.4538**

**Moved: Cr Mencshelyi**

**Seconded: Cr Curtis**

**That Council receive the payments for the period 1 July 2022 to 31 July 2022, as listed:**

- **Municipal Fund payment cheque numbers 35509 to 35515 Total \$35,158.28.**
- **Municipal Fund EFT44134 to EFT44460 Total \$1,922,165.42.**
- **Direct Debits Total \$92,241.22.**
- **Payroll Total \$450,983.16**

**TOTAL: \$2,500,548.08**

**Which have been made in accordance with the delegated authority reference number (M/F/F/Regs LGA 1995 S5.42).**

**CARRIED 10/0**

### Attachment 1: Accounts & Statements of Accounts – July 2022

Date: 01/08/2022  
Time: 9:17:37AM

Shire of Northam

USER: Louise Harris  
PAGE: 1

Cheque /EFT No	Date	Name	Invoice Description	Bank Code	INV Amount	Amount
35509	12/07/2022	COMMISSIONER OF POLICE	NORTHAM BILYA FESTIVAL 2022 - ROAD CLOSURE FEE	1		85.70
INV MB 06006/07/2022		COMMISSIONER OF POLICE	NORTHAM BILYA FESTIVAL 2022 - ROAD CLOSURE FEE	1	85.70	
35510	12/07/2022	FRANCES HELEN DOYE	RATES CREDIT REFUND FOR ASSESSMENT A12572	1		491.03
INV A1257230/06/2022		FRANCES HELEN DOYE	RATES CREDIT REFUND FOR ASSESSMENT A12572		491.03	
35511	12/07/2022	PETTY CASH	PETTY CASH - NORTHAM REC & POOL - BUNNINGS / NEWPOWER / NORTHAM BETTA HOMES / COLES / DUNNINGS / SHOE REPAIR MAN / RET DOT	1		133.75
INV DE 300630/06/2022		PETTY CASH	PETTY CASH - NORTHAM REC & POOL - BUNNINGS / NEWPOWER / NORTHAM BETTA HOMES / COLES / DUNNINGS / SHOE REPAIR MAN / RET DOT	1	133.75	
35512	12/07/2022	SHIRE OF NORTHAM	MONTHLY BSL FEES COLLECTED FOR THE BUILDING COMMISSION FOR THE MONTH OF JUNE 2022	1		168.25
INV T1079 08/07/2022		SHIRE OF NORTHAM	PAYMENT FOR COLLECTION OF BCITF FEES ON BEHALF OF THE CONSTRUCTION TRAINING FUND FOR THE MONTH OF JUNE 2022	1	8.25	
INV T1080 08/07/2022		SHIRE OF NORTHAM	MONTHLY BSL FEES COLLECTED FOR THE BUILDING COMMISSION FOR THE MONTH OF JUNE 2022	1	160.00	
35513	12/07/2022	WATER CORPORATION	9007868583 WUNDOWIE SWIMMING POOL - 19/04/2022 to 13/06/2022	1		2,438.82
INV 900786815/06/2022		WATER CORPORATION	9007868583 WUNDOWIE SWIMMING POOL - 19/04/2022 to 13/06/2022		2,124.48	
INV 900786915/06/2022		WATER CORPORATION	9007869121 WUNDOWIE LIBRARY & GARDENS - 19/04/2022 to 13/06/2022		314.34	
35514	22/07/2022	SHIRE OF NORTHAM	12 MTHS REGISTRATION FOR N460 - 01/08/2022-31/07/2023	1		23,861.30
INV N40157 20/06/2022		SHIRE OF NORTHAM	12 MTHS REGISTRATION FOR N40157 - 01/08/2022-31/07/2023		24.85	
INV N10863 20/06/2022		SHIRE OF NORTHAM	12 MTHS REGISTRATION FOR N10863 - 01/08/2022-31/07/2023		82.85	
INV N.017 20/06/2022		SHIRE OF NORTHAM	12 MTHS REGISTRATION FOR N.017 - 01/08/2022-31/07/2023		82.85	
INV 1TNU4820/06/2022		SHIRE OF NORTHAM	12 MTHS REGISTRATION FOR 1TNU484 -01/08/2022-31/07/2023		24.85	

Date: 01/08/2022  
Time: 9:17:37AM

Shire of Northam

USER: Louise Harris  
PAGE: 2 10

Cheque /EFT No	Date	Name	Invoice Description	Bank Code	INV Amount	Amount
INV N460	20/06/2022	SHIRE OF NORTHAM	12 MTHS REGISTRATION FOR N460 - 01/08/2022-31/07/2023		436.40	
INV 1GZQ71	20/06/2022	SHIRE OF NORTHAM	12 MTHS REGISTRATION FOR 1GZQ718 - 01/08/2022-31/07/2023		406.70	
INV N.4100	20/06/2022	SHIRE OF NORTHAM	12 MTHS REGISTRATION FOR N.4100 - 01/08/2022-31/07/2023		406.70	
INV N.4099	20/06/2022	SHIRE OF NORTHAM	12 MTHS REGISTRATION FOR N.4099 -01/08/2022-31/07/2023		406.70	
INV KILLAR20	20/06/2022	SHIRE OF NORTHAM	12 MTHS REGISTRATION FOR KILLARA - 01/08/2022-31/07/2023		436.40	
INV KILLAR20	20/06/2022	SHIRE OF NORTHAM	12 MTHS REGISTRATION FOR KILLARA3 - 01/08/2022-31/07/2023		436.40	
INV N.002	20/06/2022	SHIRE OF NORTHAM	12 MTHS REGISTRATION FOR N.002 -01/08/2022-31/07/2023		263.65	
INV 8TF590	20/06/2022	SHIRE OF NORTHAM	12 MTHS REGISTRATION FOR 8TF590 - 01/08/2022-31/07/2023		24.85	
INV N10996	20/06/2022	SHIRE OF NORTHAM	12 MTHS REGISTRATION FOR N10996 - 01/08/2022-31/07/2023		406.70	
INV N11063	20/06/2022	SHIRE OF NORTHAM	12 MTHS REGISTRATION FOR N11063 - 01/08/2022-31/07/2023		82.85	
INV 1TQM5	20/06/2022	SHIRE OF NORTHAM	12 MTHS REGISTRATION FOR 1TQM573 -01/08/2022-31/07/2023		24.85	
INV 1TQM5	20/06/2022	SHIRE OF NORTHAM	12 MTHS REGISTRATION FOR 1TQM574 - 01/08/2022-31/07/2023		24.85	
INV N.4174	20/06/2022	SHIRE OF NORTHAM	12 MTHS REGISTRATION FOR N.4174 -01/08/2022-31/07/2023		82.85	
INV N11142	20/06/2022	SHIRE OF NORTHAM	12 MTHS REGISTRATION FOR N11142 -01/08/2022-31/07/2023		406.70	
INV N40090	20/06/2022	SHIRE OF NORTHAM	12 MTHS REGISTRATION FOR N40090 - 01/08/2022-31/07/2023		24.85	
INV 1TRA5020	20/06/2022	SHIRE OF NORTHAM	12 MTHS REGISTRATION FOR 1TRA502 - 01/08/2022-31/07/2023		24.85	
INV N11164	20/06/2022	SHIRE OF NORTHAM	12 MTHS REGISTRATION FOR N11164 - 01/08/2022-31/07/2023		406.70	
INV N11267	20/06/2022	SHIRE OF NORTHAM	12 MTHS REGISTRATION FOR N11267 - 01/08/2022-31/07/2023		406.70	
INV N.5380	20/06/2022	SHIRE OF NORTHAM	12 MTHS REGISTRATION FOR N.5380 - 01/08/2022-31/07/2023		24.85	

Ordinary Council Meeting Minutes  
17 August 2022



Date: 01/08/2022  
Time: 9:17:37AM

Shire of Northam

USER: Louise Harris  
PAGE: 3

Cheque /EFT No	Date	Name	Invoice Description	Bank Code	INV Amount	Amount
INV N11187	20/06/2022	SHIRE OF NORTHAM	12 MTHS REGISTRATION FOR N11187 - 01/08/2022-31/07/2023		406.70	
INV N11291	20/06/2022	SHIRE OF NORTHAM	12 MTHS REGISTRATION FOR N11291 - 01/08/2022-31/07/2023		406.70	
INV 1TRB6720	20/06/2022	SHIRE OF NORTHAM	12 MTHS REGISTRATION FOR 1TRB674 - 01/08/2022-31/07/2023		24.85	
INV N.15088	20/06/2022	SHIRE OF NORTHAM	12 MTHS REGISTRATION FOR N.15088 - 01/08/2022-31/07/2023		24.85	
INV N577	20/06/2022	SHIRE OF NORTHAM	12 MTHS REGISTRATION FOR N577 -01/08/2022-31/07/2023		406.70	
INV N642	20/06/2022	SHIRE OF NORTHAM	12 MTHS REGISTRATION FOR N642 - 01/08/2022-31/07/2023		263.65	
INV N.003	20/06/2022	SHIRE OF NORTHAM	12 MTHS REGISTRATION FOR N.003 -01/08/2022-31/07/2023		406.70	
INV N.007	20/06/2022	SHIRE OF NORTHAM	12 MTHS REGISTRATION FOR N.007 -01/08/2022-31/07/2023		406.70	
INV N.1709	20/06/2022	SHIRE OF NORTHAM	12 MTHS REGISTRATION FOR N.1709 - 01/08/2022-31/07/2023		406.70	
INV N.1508020	20/06/2022	SHIRE OF NORTHAM	12 MTHS REGISTRATION FOR N.15080 - 01/08/2022-31/07/2023		24.85	
INV N.006	20/06/2022	SHIRE OF NORTHAM	12 MTHS REGISTRATION FOR N.006 -01/08/2022-31/07/2023		82.85	
INV N.3505	20/06/2022	SHIRE OF NORTHAM	12 MTHS REGISTRATION FOR N.3505 - 01/08/2022-31/07/2023		263.65	
INV 1TSH2720	20/06/2022	SHIRE OF NORTHAM	12 MTHS REGISTRATION FOR 1TSH272 - 01/08/2022-31/07/2023		24.85	
INV N11469	20/06/2022	SHIRE OF NORTHAM	12 MTHS REGISTRATION FOR N11469 - 01/08/2022-31/07/2023		406.70	
INV 1TSO1820	20/06/2022	SHIRE OF NORTHAM	12 MTHS REGISTRATION FOR 1TSO183 -01/08/2022-31/07/2023		24.85	
INV N.4346	20/06/2022	SHIRE OF NORTHAM	12 MTHS REGISTRATION FOR N.4346 - 01/08/2022-31/07/2023		263.65	
INV N.001	20/06/2022	SHIRE OF NORTHAM	12 MTHS REGISTRATION FOR N.001 -01/08/2022-31/07/2023		82.85	
INV N11120	20/06/2022	SHIRE OF NORTHAM	12 MTHS REGISTRATION FOR N11120 - 01/08/2022-31/07/2023		436.40	
INV N79	20/06/2022	SHIRE OF NORTHAM	12 MTHS REGISTRATION FOR N79 -01/08/2022-31/07/2023		406.70	
INV 1TTO4120	20/06/2022	SHIRE OF NORTHAM	12 MTHS REGISTRATION FOR 1TTO411 -01/08/2022-31/07/2023		24.85	

Date: 01/08/2022  
Time: 9:17:37AM

Shire of Northam

USER: Louise Harris  
PAGE: 4 10

Cheque /EFT No	Date	Name	Invoice Description	Bank Code	INV Amount	Amount
INV KILLAR20/06/2022	20/06/2022	SHIRE OF NORTHAM	12 MTHS REGISTRATION FOR KILLARA4 - 01/08/2022-31/07/2023		436.40	
INV N.3856	20/06/2022	SHIRE OF NORTHAM	12 MTHS REGISTRATION FOR N40157 - 01/08/2022-31/07/2023		263.65	
INV N10759	20/06/2022	SHIRE OF NORTHAM	12 MTHS REGISTRATION FOR N10759 - 01/08/2022-31/07/2023		406.70	
INV N.4012	20/06/2022	SHIRE OF NORTHAM	12 MTHS REGISTRATION FOR N.4012 -01/08/2022-31/07/2023		406.70	
INV N.009	20/06/2022	SHIRE OF NORTHAM	12 MTHS REGISTRATION FOR N.009 -01/08/2022-31/07/2023		436.40	
INV N.4013	20/06/2022	SHIRE OF NORTHAM	12 MTHS REGISTRATION FOR N.4013 - 01/08/2022-31/07/2023		406.70	
INV KILLAR20/06/2022	20/06/2022	SHIRE OF NORTHAM	12 MTHS REGISTRATION FOR KILLARA2 - 01/08/2022-31/07/2023		436.40	
INV N.004	20/06/2022	SHIRE OF NORTHAM	12 MTHS REGISTRATION FOR N.004 -01/08/2022-31/07/2023		82.85	
INV N254	20/06/2022	SHIRE OF NORTHAM	12 MTHS REGISTRATION FOR N254 - 01/08/2022-31/07/2023		436.40	
INV N10721	20/06/2022	SHIRE OF NORTHAM	12 MTHS REGISTRATION FOR N10721 - 01/08/2022-31/07/2023		406.70	
INV N11184	20/06/2022	SHIRE OF NORTHAM	12 MTHS REGISTRATION FOR N11184 - 01/08/2022-31/07/2023		406.70	
INV N.4468	20/06/2022	SHIRE OF NORTHAM	12 MTHS REGISTRATION FOR N.4468 - 01/08/2022-31/07/2023		82.85	
INV N.3862	20/06/2022	SHIRE OF NORTHAM	12 MTHS REGISTRATION FOR N.3862 - 01/08/2022-31/07/2023		82.85	
INV N11069	20/06/2022	SHIRE OF NORTHAM	12 MTHS REGISTRATION FOR N11069 - 01/08/2022-31/07/2023		436.40	
INV N10734	20/06/2022	SHIRE OF NORTHAM	12 MTHS REGISTRATION FOR N10734 -01/08/2022-31/07/2023		436.40	
INV N11196	20/06/2022	SHIRE OF NORTHAM	13 MTHS REGISTRATION FOR N11196 - 01/08/2022-31/07/2023		436.40	
INV N11657	20/06/2022	SHIRE OF NORTHAM	15 MTHS REGISTRATION FOR N11657 - 01/08/2022-31/07/2023		406.70	
INV N.4487	20/06/2022	SHIRE OF NORTHAM	12 MTHS REGISTRATION FOR N.4487 -01/08/2022-31/07/2023		406.70	
INV 1GZZ1220/06/2022	20/06/2022	SHIRE OF NORTHAM	12 MTHS REGISTRATION FOR 1GZZ129 - 01/08/2022-31/07/2023		82.85	

Ordinary Council Meeting Minutes  
17 August 2022



Date: 01/08/2022  
Time: 9:17:37AM

Shire of Northam

USER: Louise Harris  
PAGE: 5 5

Cheque/EFT No	Date	Name	Invoice Description	Bank Code	INV Amount	Amount
INV N.4490	20/06/2022	SHIRE OF NORTHAM	12 MTHS REGISTRATION FOR N.4490 -01/08/2022-31/07/2023		406.70	
INV N11684	20/06/2022	SHIRE OF NORTHAM	12 MTHS REGISTRATION FOR N11684 -01/08/2022-31/07/2023		436.40	
INV N.3805	20/06/2022	SHIRE OF NORTHAM	12 MTHS REGISTRATION FOR N.3805 -01/08/2022-31/07/2023		406.70	
INV N.4096	20/06/2022	SHIRE OF NORTHAM	12 MTHS REGISTRATION FOR N.4096 -01/08/2022-31/07/2023		406.70	
INV N.3871	20/06/2022	SHIRE OF NORTHAM	12 MTHS REGISTRATION FOR N.3871 -01/08/2022-31/07/2023		82.85	
INV N11206	20/06/2022	SHIRE OF NORTHAM	12 MTHS REGISTRATION FOR N11206 -01/08/2022-31/07/2023		406.70	
INV 1TOV60	20/06/2022	SHIRE OF NORTHAM	12 MTHS REGISTRATION FOR 1TOV603 -01/08/2022-31/07/2023		24.85	
INV 1TAA11	20/06/2022	SHIRE OF NORTHAM	12 MTHS REGISTRATION FOR 1TAA111 -01/08/2022-31/07/2023		24.85	
INV N.4531	20/06/2022	SHIRE OF NORTHAM	12 MTHS REGISTRATION FOR N.4531 -01/08/2022-31/07/2023		82.85	
INV N11363	20/06/2022	SHIRE OF NORTHAM	12 MTHS REGISTRATION FOR N11363 -01/08/2022-31/07/2023		436.40	
INV N11114	20/06/2022	SHIRE OF NORTHAM	12 MTHS REGISTRATION FOR N11114 -01/08/2022-31/07/2023		436.40	
INV N.3433	20/06/2022	SHIRE OF NORTHAM	12 MTHS REGISTRATION FOR N.3433 -01/08/2022-31/07/2023		436.40	
INV N11084	20/06/2022	SHIRE OF NORTHAM	12 MTHS REGISTRATION FOR N11084 -01/08/2022-31/07/2023		406.70	
INV 1THT84	20/06/2022	SHIRE OF NORTHAM	12 MTHS REGISTRATION FOR 1THT841 -01/08/2022-31/07/2023		24.85	
INV 1TKK95	20/06/2022	SHIRE OF NORTHAM	12 MTHS REGISTRATION FOR 1TKK954 -01/08/2022-31/07/2023		24.85	
INV N.5477	20/06/2022	SHIRE OF NORTHAM	12 MTHS REGISTRATION FOR N.5477 -01/08/2022-31/07/2023		24.85	
INV 1TLA33	20/06/2022	SHIRE OF NORTHAM	12 MTHS REGISTRATION FOR 1TLA331 -01/08/2022-31/07/2023		24.85	
INV N.4259	20/06/2022	SHIRE OF NORTHAM	12 MTHS REGISTRATION FOR N.4259 -01/08/2022-31/07/2023		406.70	



Ordinary Council Meeting Minutes  
17 August 2022



Date: 01/08/2022  
Time: 9:17:37AM

Shire of Northam

USER: Louise Harris  
PAGE: 6 6

Cheque /EFT No	Date	Name	Invoice Description	Bank Code	INV Amount	Amount
INV N11254	20/06/2022	SHIRE OF NORTHAM	12 MTHS REGISTRATION FOR N11254 - 01/08/2022-31/07/2023		406.70	
INV N.4098	20/06/2022	SHIRE OF NORTHAM	12 MTHS REGISTRATION FOR N.4098 - 01/08/2022-31/07/2023		436.40	
INV N9166	20/06/2022	SHIRE OF NORTHAM	12 MTHS REGISTRATION FOR N9166 -01/08/2022-31/07/2023		82.85	
INV N11131	20/06/2022	SHIRE OF NORTHAM	12 MTHS REGISTRATION FOR N11131 -01/08/2022-31/07/2023		436.40	
INV N.3333	20/06/2022	SHIRE OF NORTHAM	12 MTHS REGISTRATION FOR N.3333 - 01/08/2022-31/07/2023		406.70	
INV 1TVZ2420	20/06/2022	SHIRE OF NORTHAM	12 MTHS REGISTRATION FOR 1TVZ247 - 01/08/2022-31/07/2023		24.85	
INV N10938	20/06/2022	SHIRE OF NORTHAM	12 MTHS REGISTRATION FOR N10938 -01/08/2022-31/07/2023		406.70	
INV N9467	20/06/2022	SHIRE OF NORTHAM	12 MTHS REGISTRATION FOR N9467 - 01/08/2022-31/07/2023		436.40	
INV 1TLJ76720	20/06/2022	SHIRE OF NORTHAM	12 MTHS REGISTRATION FOR 1TLJ767 - 01/08/2022-31/07/2023		24.85	
INV N.2116	20/06/2022	SHIRE OF NORTHAM	12 MTHS REGISTRATION FOR N.2116 - 01/08/2022-31/07/2023		24.85	
INV N.1520420	20/06/2022	SHIRE OF NORTHAM	12 MTHS REGISTRATION FOR N.15204 -01/08/2022-31/07/2023		24.85	
INV N.4651	20/06/2022	SHIRE OF NORTHAM	12 MTHS REGISTRATION FOR N.4651 -01/08/2022-31/07/2023		406.70	
35515	22/07/2022	WATER CORPORATION	9007913575 STANDPIPE - PEEL TCE - 19/05/2022 to 13/07/2022	1		7,979.43
INV 900794505	07/2022	WATER CORPORATION	9007945104 KATRINE TOILETS - C2/05/2022 to 03/07/2022		16.37	
INV 901115405	07/2022	WATER CORPORATION	9011154743 COMMONAGE - C2/05/2022 to 03/07/2022		650.19	
INV 900790107	07/2022	WATER CORPORATION	9007901603 RAILWAY MUSEUM - 05/05/2022 to 05/07/2022		171.51	
INV 900872907	07/2022	WATER CORPORATION	9008729788 SHIRE ADMINISTRATION BUILDING - 05/05/2022 to 05/07/2022		215.31	
INV 900789908	07/2022	WATER CORPORATION	9007899961 GIRL GUIDES HALL - 05/05/2022 to 06/07/2022		72.27	
INV 900790308	07/2022	WATER CORPORATION	9007903799 TOWN & LESSER HALL - 06/05/2022 to 06/07/2022		370.12	

Ordinary Council Meeting Minutes  
17 August 2022



Date: 01/08/2022  
Time: 9:17:37AM

Shire of Northam

USER: Louise Harris  
PAGE: 7 5

Cheque/EFT No	Date	Name	Invoice Description	Bank Code	INV Amount	Amount
INV 900790613/07/2022		WATER CORPORATION	9007906746 MEN'S SHED / OLD FIRE STATION - 17/05/2022 to 11/07/2022		129.58	
INV 900790613/07/2022		WATER CORPORATION	9007906922 OLD INFANT HEALTH CLINIC - 16/05/2022 to 11/07/2022		112.96	
INV 900790813/07/2022		WATER CORPORATION	9007908063 OLD POST OFFICE BUILDING - 16/05/2022 to 11/07/2022		326.07	
INV 900790813/07/2022		WATER CORPORATION	9007908071 OLD GIRLS SCHOOL - 16/05/2022 to 11/07/2022		72.27	
INV 900790913/07/2022		WATER CORPORATION	9007909752 YOUTH PARK - 17/05/2022 to 11/07/2022		40.94	
INV 900790913/07/2022		WATER CORPORATION	9007909787 JUBILEE OVAL - 17/05/2022 to 11/07/2022		693.25	
INV 900790414/07/2022		WATER CORPORATION	9007904089 NORTHAM LIBRARY - 17/05/2022 to 12/07/2022		88.64	
INV 900790714/07/2022		WATER CORPORATION	9007907431 BERNARD PARK - 17/05/2022 to 12/07/2022		1,096.14	
INV 900790714/07/2022		WATER CORPORATION	9007907458 BERNARD PARK SUB METER - 17/05/2022 to 12/07/2022		94.35	
INV 900792914/07/2022		WATER CORPORATION	9007929497 AVON MALL - 17/05/2022 to 12/07/2022		161.01	
INV 900790314/07/2022		WATER CORPORATION	9007903879 108 WELLINGTON ST - ST JOHN PUBLIC OPEN SPACE - 17/05/2022 to 11/07/2022		56.71	
INV 901107014/07/2022		WATER CORPORATION	9011070427 RIVERSEDGE CAFE (SNACKBAR) - WASTE - 01/07/2022 to 31/08/2022		236.56	
INV 900790314/07/2022		WATER CORPORATION	9007903991 ST JOHNS HALL - 17/05/2022 to 11/07/2022		151.91	
INV 900790414/07/2022		WATER CORPORATION	9007904003 MEMORIAL HALL - 17/05/2022 to 11/07/2022		319.86	
INV 900790414/07/2022		WATER CORPORATION	9007904062 OLD TOWN BUILDING - 17/05/2022 to 12/07/2022		80.21	
INV 900791315/07/2022		WATER CORPORATION	9007913102 NORTHAM DEPOT - BYFIELD ST - 19/05/2022 to 13/07/2022		166.47	
INV 900791315/07/2022		WATER CORPORATION	9007913567 NORTHAM DEPOT - PEEL ST - 19/05/2022 to 13/07/2022		292.00	
INV 900791315/07/2022		WATER CORPORATION	9007913575 STANDPIPE - PEEL TCE - 19/05/2022 to 13/07/2022		1,910.30	
INV 900791718/07/2022		WATER CORPORATION	9007917058 CEMETERY - 19/05/2022 to 14/07/2022		406.62	
INV 901247518/07/2022		WATER CORPORATION	9012475784 GARDEN TAYLOR ST - 01/07/2022 to 31/08/2022		47.81	
EFT44134	04/07/2022	WCP CIVIL PTY LTD	REFUND - BPAY PAYMENT 29/06/22- OVERPAYMENT OF INVOICE 26804	1		26,804.00

Ordinary Council Meeting Minutes  
17 August 2022

Date: 01/08/2022  
Time: 9:17:37AM

Shire of Northam

USER: Louise Harris  
PAGE: 8 6

Cheque /EFT No	Date	Name	Invoice Description	Bank Code	INV Amount	Amount
INV 26804	17/06/2022	WCP CIVIL PTY LTD	REFUND - BPAY PAYMENT 29/06/22- OVERPAYMENT OF INVOICE 26804	1	26,804.00	
EFT44135	05/07/2022	ACES ANIMAL CARE EQUIPMENT SERVICES PTY LTD	CSS-C SHIELD SPRAY	1		482.15
INV 000359423/06/2022		ACES ANIMAL CARE EQUIPMENT SERVICES PTY LTD	CSS-C SHIELD SPRAY	1	482.15	
EFT44136	05/07/2022	ADVANCED TRAFFIC MANAGEMENT (WA) PTY LTD	3 X TRAFFIC CONTROLLERS WELLINGTON / ROBINSON / FITZGERALD ST	1		958.10
INV 001535123/02/2022		ADVANCED TRAFFIC MANAGEMENT (WA) PTY LTD	3 X TRAFFIC CONTROLLERS WELLINGTON / ROBINSON / FITZGERALD ST	1	958.10	
EFT44137	05/07/2022	AMPAC DEBT RECOVERY (WA) P/L	DEBT RECOVERY FOR PERIOD ENDING 17 JUNE 2022	1		166.93
INV 85236	23/06/2022	AMPAC DEBT RECOVERY (WA) P/L	DEBT RECOVERY FOR PERIOD ENDING 17 JUNE 2022	1	166.93	
EFT44138	05/07/2022	ASTRO SYNTHETIC TURF	MANUFACTURE HEAVY DUTY RUBBER CRICKET PITCH COVERS 2170 X 2370 30MM DEEP 2030 X 2370 30MM DEEP	1		1,925.00
INV 000011823/06/2022		ASTRO SYNTHETIC TURF	MANUFACTURE HEAVY DUTY RUBBER CRICKET PITCH COVERS 2170 X 2370 30MM DEEP 2030 X 2370 30MM DEEP	1	1,925.00	
EFT44139	05/07/2022	AUSTRALIAN TAXATION OFFICE - PAYG	PAYG FOR PAY WEEK ENDING 21/06/2022	1		61,063.20
INV PAYG 221/06/2022		AUSTRALIAN TAXATION OFFICE - PAYG	PAYG FOR PAY WEEK ENDING 21/06/2022	1	61,063.20	
EFT44140	05/07/2022	AVON VALLEY ENVIRONMENTAL SOCIETY	2X RIVER WALK TOURS 16 JUNE 2022	1		200.00
INV 24	22/06/2022	AVON VALLEY ENVIRONMENTAL SOCIETY	2X RIVER WALK TOURS 16 JUNE 2022	1	200.00	
EFT44141	05/07/2022	BLACKWELL PLUMBING & GAS PTY LTD	CLACKLINE FIRE SHED. INSTALL WATER FILTRATION FROM RAINWATER TANK.	1		677.20
INV INV-26321/06/2022		BLACKWELL PLUMBING & GAS PTY LTD	REPAIR TO URINAL IN COURTS (ONLY ONE SIDE WORKING)	1	173.40	
INV INV-26328/06/2022		BLACKWELL PLUMBING & GAS PTY LTD	SHOWER 4 IN CHANGEROOMS (COURTS) LEAKING CLACKLINE FIRE SHED. INSTALL WATER FILTRATION FROM RAINWATER TANK.	1	503.80	

Ordinary Council Meeting Minutes  
17 August 2022



Date: 01/08/2022  
Time: 9:17:37AM

Shire of Northam

USER: Louise Harris  
PAGE: 9 13

Cheque /EFT No	Date	Name	Invoice Description	Bank Code	INV Amount	Amount
EFT44142	05/07/2022	BOC LIMITED	11 X 400C OXYGEN MEDICAL C SIZE* RENTAL FEE 29.05.2022 TO 27.06.2022	1		68.90
INV 403157628/06/2022		BOC LIMITED	11 X 400C OXYGEN MEDICAL C SIZE* RENTAL FEE 29.05.2022 TO 27.06.2022	1	68.90	
EFT44143	05/07/2022	BUNNINGS BUILDING SUPPLIES P/L	GIFTS FOR CITIZENSHIP CEREMONY ON 24/06/2022	1		222.04
INV 2182/0022/06/2022		BUNNINGS BUILDING SUPPLIES P/L	CRAFTRIGHT 2 PIECE CHISEL SET AND PLASTIC TUBING	1	29.15	
INV 2182/0023/06/2022		BUNNINGS BUILDING SUPPLIES P/L	YATES ROSE SHIELD 50L / RICHGRO ANT KILLER 3L	1	53.35	
INV 2182/0023/06/2022		BUNNINGS BUILDING SUPPLIES P/L	BLUELINE FITTINGS AND POLY FITTINGS FOR WUNDOWIE RV PARK	1	48.50	
INV 2182/0024/06/2022		BUNNINGS BUILDING SUPPLIES P/L	GIFTS FOR CITIZENSHIP CEREMONY ON 24/06/2022	1	91.04	
EFT44144	05/07/2022	CADD'S FASHIONS	JBS SOFT SHELL JACKET BLACK SIZE 14	1		169.70
INV 22-000016/06/2022		CADD'S FASHIONS	JBS SOFT SHELL JACKET BLACK SIZE 14	1	169.70	
EFT44145	05/07/2022	CLOUD COLLECTIONS PTY LTD	DEBT COLLECTION FOR MAY 2022	1		2,036.68
INV 3109	01/06/2022	CLOUD COLLECTIONS PTY LTD	DEBT COLLECTION FOR MAY 2022	1	2,036.68	
EFT44146	05/07/2022	COUNTRYWIDE GROUP	EDGER BLADES	1		94.60
INV ACC00127/06/2022		COUNTRYWIDE GROUP	8X CHAINSAW FILES	1	44.00	
INV ACC00128/06/2022		COUNTRYWIDE GROUP	EDGER BLADES	1	50.60	
EFT44147	05/07/2022	DAIMLER TRUCKS PERTH	PN1805 - 980U/QMX005028 TANK FILLER CAP FOR ADBLUE	1		94.59
INV KA980007/04/2022		DAIMLER TRUCKS PERTH	PN1805 - 980U/QMX005028 TANK FILLER CAP FOR ADBLUE	1	94.59	
EFT44148	05/07/2022	DAMIAN BARNETT	REIMBURSEMENT FOR PURCHASE OF 30MM SOCKET	1		12.99
INV 100029821/06/2022		DAMIAN BARNETT	REIMBURSEMENT FOR PURCHASE OF 30MM SOCKET	1	12.99	
EFT44149	05/07/2022	DCM CARPENTRY & MAINTENANCE	REPAIR SOLAR LEAKS FOR NORTHAM POOL - STADIUM ROOF	1		2,321.00
INV 1399	21/06/2022	DCM CARPENTRY & MAINTENANCE	RESREW WOOD AROUND ALL THE WOODEN SEATING AROUND POOL DECK	1	880.00	

Ordinary Council Meeting Minutes  
17 August 2022



Date: 01/08/2022  
Time: 9:17:37AM

Shire of Northam

USER: Louise Harris  
PAGE: 10 10

Cheque /EFT No	Date	Name	Invoice Description	Bank Code	INV Amount	Amount
INV 1406	26/06/2022	DCM CARPENTRY & MAINTENANCE	REPAIR SOLAR LEAKS FOR NORTHAM POOL - STADIUM ROOF	1	1,441.00	
EFT44150	05/07/2022	DONALD GEORGE MOORE	RATES CREDIT REFUND FOR ASSESSMENT A12426	1		696.88
INV A12426	30/06/2022	DONALD GEORGE MOORE	RATES CREDIT REFUND FOR ASSESSMENT A12426		696.88	
EFT44151	05/07/2022	DRACO AIR PTY LTD	REPAIRS TO KILLARA KITCHEN COMMERCIAL FRIDGE	1		1,647.98
INV 14417	21/02/2022	DRACO AIR PTY LTD	BAKERS HILL PAVILION. REPAIR AIRCONDITIONER TO FROM ROOM.	1	242.00	
INV 14662	01/06/2022	DRACO AIR PTY LTD	REPAIRS TO KILLARA KITCHEN COMMERCIAL FRIDGE	1	1,163.98	
INV 14711	28/06/2022	DRACO AIR PTY LTD	REC CENTRE. REPAIR AIRCON NOT WORKING.	1	242.00	
EFT44152	05/07/2022	E FIRE & SAFETY	MONTHLY ROUTINE MAINTENANCE CHARGES FOR THE TESTING OF THE FIRE DETECTION SYSTEM AT KILLARA - JUNE 2022	1		677.05
INV 566330	28/06/2022	E FIRE & SAFETY	MONTHLY ROUTINE MAINTENANCE CHARGES FOR THE TESTING OF THE FIRE DETECTION SYSTEM AT NORTHAM RECREATION CENTRE - JUNE 2022	1	254.65	
INV 566333	28/06/2022	E FIRE & SAFETY	MONTHLY ROUTINE MAINTENANCE CHARGES FOR THE TESTING OF THE FIRE DETECTION SYSTEM AT KILLARA - JUNE 2022	1	422.40	
EFT44153	05/07/2022	EVAN DAVID WESLEY	RATES CREDIT REFUND FOR ASSESSMENT A1849	1		763.50
INV A1849	30/06/2022	EVAN DAVID WESLEY	RATES CREDIT REFUND FOR ASSESSMENT A1849		763.50	
EFT44154	05/07/2022	HERRON TODD WHITE (WESTERN AUSTRALIA) PTY LTD	VALUATION FOR AIRPORT HANGAR SITES	1		4,180.00
INV JB292632	7/04/2022	HERRON TODD WHITE (WESTERN AUSTRALIA) PTY LTD	VALUATION FOR AIRPORT HANGAR SITES	1	4,180.00	
EFT44155	05/07/2022	JLO DESIGNS	DESIGN APRIL SCHOOL HOLIDAY FLIER 2022	1		65.00
INV 470	29/03/2022	JLO DESIGNS	DESIGN APRIL SCHOOL HOLIDAY FLIER 2022	1	65.00	
EFT44156	05/07/2022	KLEENWEST DISTRIBUTORS	TRIGGER SPRAY BOTTLES/ GLOVES/ WIPES/ LABELS	1		255.15
INV 000700022	06/2022	KLEENWEST DISTRIBUTORS	TRIGGER SPRAY BOTTLES/ GLOVES/ WIPES/ LABELS	1	255.15	

Ordinary Council Meeting Minutes  
17 August 2022

Date: 01/08/2022  
Time: 9:17:37AM

Shire of Northam

USER: Louise Harris  
PAGE: 11 13

Cheque /EFT No	Date	Name	Invoice Description	Bank Code	INV Amount	Amount
EFT44157	05/07/2022	LANDGATE	RURAL UV GENERAL REVALUATION 2021/2022	1		15,283.58
INV 374581	16/05/2022	LANDGATE	RURAL UV GENERAL REVALUATION 2021/2022	1	14,511.00	
INV 374716	20/05/2022	LANDGATE	CONSOLIDATED MINING TENEMENT ROLL	1	494.30	
INV 374814	25/05/2022	LANDGATE	GROSS RENTAL VALUATIONS CHARGEABLE SCHEDULE: G2022/06 DATE: 16/04/2022 TO 13/05/2022	1	150.04	
INV 374786	25/05/2022	LANDGATE	RURAL UV'S CHARGEABLE SCHEDULE: R2022/4 DATE: 02/04/2022 TO 13/05/2022	1	86.94	
INV 374898	27/05/2022	LANDGATE	MINING TENEMENTS CHARGEABLE SCHEDULE: M2022/3 DATE: 08/04/2022 TO 04/05/2022	1	41.30	
EFT44158	05/07/2022	LAURA ANNE-MAREE RUSS	RATES CREDIT REFUND FOR ASSESSMENT A10866	1		98.88
INV A10866	30/06/2022	LAURA ANNE-MAREE RUSS	RATES CREDIT REFUND FOR ASSESSMENT A10866		98.88	
EFT44159	05/07/2022	LEONIE JUNE WHISSON	RATES CREDIT REFUND FOR ASSESSMENT A15759	1		122.00
INV A15759	30/06/2022	LEONIE JUNE WHISSON	RATES CREDIT REFUND FOR ASSESSMENT A15759		122.00	
EFT44160	05/07/2022	LGIS - RISK MANAGEMENT	REGIONAL RISK COORDINATOR FEE 2021-2022 2ND INSTALLMENT	1		8,088.85
INV 156-C2221/06/2022		LGIS - RISK MANAGEMENT	REGIONAL RISK COORDINATOR FEE 2021-2022 2ND INSTALLMENT	1	8,088.85	
EFT44161	05/07/2022	MCDOWALL AFFLECK PTY LTD	CIVIL AND DUMP POINT DETAILED DESIGN AND DOCUMENTATION OF RV OLD POOL SITE AS PER QUOTE 18235	1		7,315.00
INV 612556	22/06/2022	MCDOWALL AFFLECK PTY LTD	CIVIL AND DUMP POINT DETAILED DESIGN AND DOCUMENTATION OF RV OLD POOL SITE AS PER QUOTE 18235	1	7,315.00	
EFT44162	05/07/2022	MICHAEL THOMAS MILLS	RATES CREDIT REFUND FOR ASSESSMENT A1922	1		643.58
INV A1922	30/06/2022	MICHAEL THOMAS MILLS	RATES CREDIT REFUND FOR ASSESSMENT A1922		643.58	

Ordinary Council Meeting Minutes  
17 August 2022



Date: 01/08/2022  
Time: 9:17:37AM

Shire of Northam

USER: Louise Harris  
PAGE: 12 10

Cheque /EFT No	Date	Name	Invoice Description	Bank Code	INV Amount	Amount
EFT44163	05/07/2022	MINT CIVIL PTY LTD T/AS IMMACU SWEEP	C.201819-12 STREET SWEEPING & GULLY EDUCTION SERVICES (CLEANING TOWN ROADS) / FOOTPATH & VERGE SWEEPING OF CBD FROM 20/6/2022 - 26/6/2022	1		7,801.20
INV N3016	27/06/2022	MINT CIVIL PTY LTD T/AS IMMACU SWEEP	C.201819-12 STREET SWEEPING & GULLY EDUCTION SERVICES (CLEANING TOWN ROADS) / FOOTPATH & VERGE SWEEPING OF CBD FROM 20/6/2022 - 26/6/2022	1	3,900.60	
INV N3015	27/06/2022	MINT CIVIL PTY LTD T/AS IMMACU SWEEP	C.201819-12 STREET SWEEPING & GULLY EDUCTION SERVICES (CLEANING TOWN ROADS) / C.201819-12 FOOTPATH & VERGE SWEEPING OF CBD - 13/06/2022 - 19/06/2022	1	3,900.60	
EFT44164	05/07/2022	MORRIS PEST AND WEED CONTROL	BAKERS HILL FIRE SHED. NEW BUILDING - REPLACE RODENT BAITTS AND EXTERNAL SPRAY	1		1,431.75
INV INV-21328/06/2022		MORRIS PEST AND WEED CONTROL	REC CENTRE. CHECK RODENT STATIONS AND SEE IF MORE ARE REQUIRED IN KITCHEN AREA AND DAYCARE.	1	321.75	
INV INV-21328/06/2022		MORRIS PEST AND WEED CONTROL	BAKERS HILL FIRE SHED. NEW BUILDING - REPLACE RODENT BAITTS AND EXTERNAL SPRAY	1	1,110.00	
EFT44165	05/07/2022	NORTHAM AUTOS PTY LTD T/AS NORTHAM MAZDA & NORTHAM HOLDEN	N10721 - PN1901 - VIN-MMU148MK0LH607023 - 90,000KM SERVICE REQUIRED	1		783.70
INV 137773	17/06/2022	NORTHAM AUTOS PTY LTD T/AS NORTHAM MAZDA & NORTHAM HOLDEN	N10721 - PN1901 - VIN-MMU148MK0LH607023 - 90,000KM SERVICE REQUIRED	1	783.70	
EFT44166	05/07/2022	NORTHAM COMMUNITY MEN'S SHED	REPAIR OF BENCHES FROM THE CEMETERY	1		198.00
INV 23	28/06/2022	NORTHAM COMMUNITY MEN'S SHED	REPAIR OF BENCHES FROM THE CEMETERY	1	198.00	
EFT44167	05/07/2022	NORTHAM DISTRICTS GLASS PTY LTD	TOWN AND LESSER HALL. REPLACE 3 X BROKEN WINDOWS.	1		599.00
INV INV-17024/02/2022		NORTHAM DISTRICTS GLASS PTY LTD	TOWN AND LESSER HALL. REPLACE 3 X BROKEN WINDOWS.	1	599.00	
EFT44168	05/07/2022	NORTHAM FEED & HIRE	SWAN FOOD & OTHER MISCELLANEOUS ITEMS TILL 30/06/2022	1		105.50
INV 000042920/06/2022		NORTHAM FEED & HIRE	SWAN FOOD & OTHER MISCELLANEOUS ITEMS TILL 30/06/2022	1	83.50	
INV 000042928/06/2022		NORTHAM FEED & HIRE	SWAN FOOD & OTHER MISCELLANEOUS ITEMS TILL 30/06/2022	1	22.00	
EFT44169	05/07/2022	NORTHAM TOWING SERVICE	TOWING OF CRASHED TOYOTA AURION - 1GKL 139	1		261.25

Ordinary Council Meeting Minutes  
17 August 2022



Date: 01/08/2022  
Time: 9:17:37AM

Shire of Northam

USER: Louise Harris  
PAGE: 13 13

Cheque /EFT No	Date	Name	Invoice Description	Bank Code	INV Amount	Amount
INV 211525	17/06/2022	NORTHAM TOWING SERVICE	TOWING OF CRASHED TOYOTA AURION - 1GKL 139	1	261.25	
EFT44170	05/07/2022	OASIS OUTDOOR STRUCTURES	C.202122-08 - 2021-22 FOOTPATH PROGRAM - BERNARD PARK / EAST ST / GORDON ST / MUDALLA RD / PERINA PATH	1		255,057.00
INV INV -06502/03/2022		OASIS OUTDOOR STRUCTURES	KERB/CROSSOVER WORKS FOR 17 LYON STREET AS PER QUOTE #QU0758	1	6,402.00	
INV INV -06620/06/2022		OASIS OUTDOOR STRUCTURES	C.202122-08 - 2021-22 FOOTPATH PROGRAM - BERNARD PARK / EAST ST / GORDON ST / MUDALLA RD / PERINA PATH	1	237,633.00	
INV INV -06620/06/2022		OASIS OUTDOOR STRUCTURES	C.202122-08 - VO 1 - EXTRA COSTING FOR RED COLOUR CONCRETE PATH FOR GORDON STREET AS PER QUOTE QU0771	1	1,914.00	
INV INV -06620/06/2022		OASIS OUTDOOR STRUCTURES	TREAT ACTIVE TERMITES ON BRIDGE 0608	1	8,624.00	
INV INV -06620/06/2022		OASIS OUTDOOR STRUCTURES	SUPPLY AND INSTALL PRAM RAMP ON COX STREET NORTHAM	1	484.00	
EFT44171	05/07/2022	PERTH SAFETY PRODUCTS PTY LTD - YUNGATHA PTY LTD T/AS	NO PARKING SIGNAGE / KURINGAL RD SIGN	1		138.60
INV 0001118	17/02/2022	PERTH SAFETY PRODUCTS PTY LTD - YUNGATHA PTY LTD T/AS	NO PARKING SIGNAGE / KURINGAL RD SIGN	1	138.60	
EFT44172	05/07/2022	POWERCARE	INSTALLATION OF 5X SOLAR LIGHTS AS PER QUOTE #5852	1		2,667.50
INV PC5852	16/06/2022	POWERCARE	INSTALLATION OF 5X SOLAR LIGHTS AS PER QUOTE #5852	1	2,667.50	
EFT44173	05/07/2022	PRESTIGE ALARMS	ADMIN BUILDING. QUARTERLY SECURITY ALARM MONITORING. 01/06/2022 - 31/08/2022	1		172.00
INV 000215009	05/05/2022	PRESTIGE ALARMS	ADMIN BUILDING. QUARTERLY SECURITY ALARM MONITORING. 01/06/2022 - 31/08/2022	1	172.00	
EFT44174	05/07/2022	QUIN'S GOURMET BUTCHERS	STANDING ORDER FOR MEAT DELIVERED TO KILLARA YEAR 21/22 - DELIVERED 28/6/2022	1		127.66
INV 000005828	06/06/2022	QUIN'S GOURMET BUTCHERS	STANDING ORDER FOR MEAT DELIVERED TO KILLARA YEAR 21/22 - DELIVERED 28/6/2022	1	127.66	
EFT44175	05/07/2022	RED DOT STORES	GIFT BAGS FOR CITIZENSHIP CEREMONY GIFTS ON 24/06/2022	1		16.00



Ordinary Council Meeting Minutes  
17 August 2022

Date: 01/08/2022  
Time: 9:17:37AM

Shire of Northam

USER: Louise Harris  
PAGE: 14 10

Cheque /EFT No	Date	Name	Invoice Description	Bank Code	INV Amount	Amount
INV 416927224/06/2022		RED DOT STORES	GIFT BAGS FOR CITIZENSHIP CEREMONY GIFTS ON 24/06/2022	1	16.00	
EFT44176	05/07/2022	SHARRON THERESE MILLER	RATES CREDIT REFUND FOR ASSESSMENT A12419	1		763.50
INV A12419	30/06/2022	SHARRON THERESE MILLER	RATES CREDIT REFUND FOR ASSESSMENT A12419		763.50	
EFT44177	05/07/2022	SHRED-X PTY LTD	EMPTYING OF ADMIN SHREDDER BIN	1		77.69
INV 018204731/05/2022		SHRED-X PTY LTD	EMPTYING OF ADMIN SHREDDER BIN	1	77.69	
EFT44178	05/07/2022	STALLION BUILDING CO PTY LTD T/A STALLION HOMES	VO-2 -C.202021-19 - CUTTING BACK 200MM & BACKFILL FOR SECOND TREE HOLE	1		2,615.73
INV 2054	23/06/2022	STALLION BUILDING CO PTY LTD T/A STALLION HOMES	VO-2 -C.202021-19 - CUTTING BACK 200MM & BACKFILL FOR SECOND TREE HOLE	1	2,615.73	
EFT44179	05/07/2022	STEWART & HEATON CLOTHING CO.PTY LTD	ANNUAL DFES APPROVED PPC FOR BFB VOLUNTEERS	1		412.63
INV SIN-35617/06/2022		STEWART & HEATON CLOTHING CO.PTY LTD	ANNUAL DFES APPROVED PPC FOR BFB VOLUNTEERS	1	412.63	
EFT44180	05/07/2022	SUSAN MAE CONNELL	REIMBURSEMENT OF CANCELLED "KANGAROO IN THE SKY" WORKSHOP FEE	1		10.00
INV 011804	01/04/2022	SUSAN MAE CONNELL	REIMBURSEMENT OF CANCELLED "KANGAROO IN THE SKY" WORKSHOP FEE	1	10.00	
EFT44181	05/07/2022	THEA COMMINS	BOOKMARKS	1		100.10
INV 000278915/02/2022		THEA COMMINS	BOOKMARKS	1	100.10	
EFT44182	05/07/2022	THIS IS CREATIVE PTY LTD	2022 NCC SEMINARS- VOLUMES ONE & TWO - GORDON TESTER, 25 AUGUST, PERTH CONVENTION CENTRE 9AM-1PM	1		130.00
INV 119694322/04/2022		THIS IS CREATIVE PTY LTD	2022 NCC SEMINARS- VOLUMES ONE & TWO - GORDON TESTER, 25 AUGUST, PERTH CONVENTION CENTRE 9AM-1PM	1	130.00	
EFT44183	05/07/2022	UNITED SCANNING SERVICES PTY LTD	GROUND PENETRATION RADAR SCANNING AND CABLE LOCATING WITHIN THE ROAD RESERVE SECTION OF MITCHELL AVE NORTHAM SLK2.90 TO SLK3.40	1		1,573.00

Date: 01/08/2022  
Time: 9:17:37AM

Shire of Northam

USER: Louise Harris  
PAGE: 15 13

Cheque /EFT No	Date	Name	Invoice Description	Bank Code	INV Amount	Amount
INV 220621_21/06/2022		UNITED SCANNING SERVICES PTY LTD	GROUND PENETRATION RADAR SCANNING AND CABLE LOCATING WITHIN THE ROAD RESERVE SECTION OF MITCHELL AVE NORTHAM SLK2.90 TO SLK3.40	1	1,573.00	
EFT44184	05/07/2022	WA CONTRACT RANGER SERVICES	MANAGEMENT OF SHIRE OF NORTHAM DOG IMPOUND FACILITY AS PER C.201920-09 - 13/6/22 TO 26/6/22	1		1,320.00
INV 000040427/06/2022		WA CONTRACT RANGER SERVICES	MANAGEMENT OF SHIRE OF NORTHAM DOG IMPOUND FACILITY AS PER C.201920-09 - 13/6/22 TO 26/6/22	1	1,320.00	
EFT44185	05/07/2022	WESTERN IRRIGATION PTY LTD	CONDUCT ONSITE REVIEW EACH POS AND PAW CONTAINING IRRIGATION USING RECYCLED EFFLUENT WATER. CONDUCT ONSITE REVIEW OF RECYCLED EFFLUENT SOURCE INFRASTRUCTURE. CONDUCT REVIEW OF EXISTING OPERATIONAL GUIDELINES. PROVIDE A REPORT CONTAINING THE FINDINGS OF THE ABOVE WORKS WITH INDICATIVE COSTING TO EITHER UPGRADE, OR RE-CONSTRUCT IN ACCORDANCE WITH ALL RELEVANT REGULATORY REQUIREMENTS	1		9,570.00
INV P48555	01/01/2022	WESTERN IRRIGATION PTY LTD	CONDUCT ONSITE REVIEW EACH POS AND PAW CONTAINING IRRIGATION USING RECYCLED EFFLUENT WATER. CONDUCT ONSITE REVIEW OF RECYCLED EFFLUENT SOURCE INFRASTRUCTURE. CONDUCT REVIEW OF EXISTING OPERATIONAL GUIDELINES. PROVIDE A REPORT CONTAINING THE FINDINGS OF THE ABOVE WORKS WITH INDICATIVE COSTING TO EITHER UPGRADE, OR RE-CONSTRUCT IN ACCORDANCE WITH ALL RELEVANT REGULATORY REQUIREMENTS	1	9,570.00	
EFT44186	05/07/2022	WESTWIDE AUTO ELECTRICS AND AIR CONDITIONING	PN1314 -VOLVO GRADER REPAIR HEADLIGHTS	1		510.00
INV INV-13522/06/2022		WESTWIDE AUTO ELECTRICS AND AIR CONDITIONING	PN1314 -VOLVO GRADER REPAIR HEADLIGHTS	1	510.00	

Ordinary Council Meeting Minutes  
17 August 2022



Date: 01/08/2022  
Time: 9:17:37AM

Shire of Northam

USER: Louise Harris  
PAGE: 16 10

Cheque /EFT No	Date	Name	Invoice Description	Bank Code	INV Amount	Amount
EFT44187	05/07/2022	WHEATBELT NATURAL RESOURCE MANAGEMENT	MAINTENANCE OF NORTHAM CEMETERY AS PER C.201920-17. JULY, AUGUST, SEPTEMBER & OCTOBER 2021. 4 HRS A DAY / 3 DAYS A WEEK WITH 3 CREW MEMBERS. - FORTNIGHT ENDING 17/06/2022	1		7,706.16
INV 003013407/06/2022		WHEATBELT NATURAL RESOURCE MANAGEMENT	MAINTENANCE OF NORTHAM CEMETERY AS PER C.201920-17. JULY, AUGUST, SEPTEMBER & OCTOBER 2021. 4 HRS A DAY / 3 DAYS A WEEK WITH 3 CREW MEMBERS. - FORTNIGHT ENDING 03/06/2022	1	3,669.60	
INV 003013420/06/2022		WHEATBELT NATURAL RESOURCE MANAGEMENT	MAINTENANCE OF NORTHAM CEMETERY AS PER C.201920-17. JULY, AUGUST, SEPTEMBER & OCTOBER 2021. 4 HRS A DAY / 3 DAYS A WEEK WITH 3 CREW MEMBERS. - FORTNIGHT ENDING 17/06/2022	1	4,036.56	
EFT44199	07/07/2022	ATTILA JOHN MENC SHELYI	COUNCILLOR PAYMENTS FOR JUNE 2022	1		2,154.37
INV JUNE 2 30/06/2022		ATTILA JOHN MENC SHELYI	COUNCILLOR PAYMENTS FOR JUNE 2022	1	2,071.49	
INV JUNE 2 30/06/2022		ATTILA JOHN MENC SHELYI	REVERSAL - INCORRECT PAYMENT	1	-2,071.49	
INV JUNE 2 30/06/2022		ATTILA JOHN MENC SHELYI	COUNCILLOR PAYMENTS FOR JUNE 2022	1	2,154.37	
EFT44200	07/07/2022	BROOKLANDS SUPER PTY LTD	COUNCILLOR PAYMENTS FOR JUNE 2022	1		1,100.00
INV JUNE 2 30/06/2022		BROOKLANDS SUPER PTY LTD	COUNCILLOR PAYMENTS FOR JUNE 2022	1	1,100.00	
INV JUNE 2 30/06/2022		BROOKLANDS SUPER PTY LTD	REVERSAL - INCORRECT PAYMENT	1	-1,100.00	
INV JUNE 2 30/06/2022		BROOKLANDS SUPER PTY LTD	COUNCILLOR PAYMENTS FOR JUNE 2022	1	1,100.00	
EFT44201	07/07/2022	CHRISTOPHER RICHARD ANTONIO	COUNCILLOR PAYMENTS FOR JUNE 2022	1		5,930.65
INV JUNE 2 30/06/2022		CHRISTOPHER RICHARD ANTONIO	COUNCILLOR PAYMENTS FOR JUNE 2022	1	5,483.36	
INV JUNE 2 30/06/2022		CHRISTOPHER RICHARD ANTONIO	REVERSAL - INCORRECT PAYMENT	1	-5,483.36	
INV JUNE 2 30/06/2022		CHRISTOPHER RICHARD ANTONIO	COUNCILLOR PAYMENTS FOR JUNE 2022	1	5,930.65	
EFT44202	07/07/2022	DAVID JAMES GALLOWAY	COUNCILLOR PAYMENTS FOR JUNE 2022	1		2,009.33
INV JUNE 2 30/06/2022		DAVID JAMES GALLOWAY	COUNCILLOR PAYMENTS FOR JUNE 2022	1	1,905.73	
INV JUNE 2 30/06/2022		DAVID JAMES GALLOWAY	REVERSAL - INCORRECT PAYMENT	1	-1,905.73	

Ordinary Council Meeting Minutes  
17 August 2022



Date: 01/08/2022  
Time: 9:17:37AM

Shire of Northam

USER: Louise Harris  
PAGE: 17 13

Cheque /EFT No	Date	Name	Invoice Description	Bank Code	INV Amount	Amount
INV JUNE 2 30/06/2022		DAVID JAMES GALLOWAY	COUNCILLOR PAYMENTS FOR JUNE 2022	1	2,009.33	
EFT44203	07/07/2022	DESMOND ARNOLD HUGHES	COUNCILLOR PAYMENTS FOR JUNE 2022	1		1,982.35
INV JUNE 2 30/06/2022		DESMOND ARNOLD HUGHES	COUNCILLOR PAYMENTS FOR JUNE 2022	1	1,905.73	
INV JUNE 2 30/06/2022		DESMOND ARNOLD HUGHES	REVERSAL - INCORRECT PAYMENT	1	-1,905.73	
INV JUNE 2 30/06/2022		DESMOND ARNOLD HUGHES	COUNCILLOR PAYMENTS FOR JUNE 2022	1	1,982.35	
EFT44204	07/07/2022	HAYDEN JOHN APPLETON	COUNCILLOR PAYMENTS FOR JUNE 2022	1		1,905.73
INV JUNE 2 30/06/2022		HAYDEN JOHN APPLETON	COUNCILLOR PAYMENTS FOR JUNE 2022	1	1,905.73	
INV JUNE 2 30/06/2022		HAYDEN JOHN APPLETON	REVERSAL - INCORRECT PAYMENT	1	-1,905.73	
INV JUNE 2 30/06/2022		HAYDEN JOHN APPLETON	COUNCILLOR PAYMENTS FOR JUNE 2022	1	1,905.73	
EFT44205	07/07/2022	JULIE ELLEN GREENFIELD WILLIAMS	COUNCILLOR PAYMENTS FOR JUNE 2022	1		2,065.57
INV JUNE 2 30/06/2022		JULIE ELLEN GREENFIELD WILLIAMS	COUNCILLOR PAYMENTS FOR JUNE 2022	1	1,905.73	
INV JUNE 2 30/06/2022		JULIE ELLEN GREENFIELD WILLIAMS	REVERSAL - INCORRECT PAYMENT	1	-1,905.73	
INV JUNE 2 30/06/2022		JULIE ELLEN GREENFIELD WILLIAMS	COUNCILLOR PAYMENTS FOR JUNE 2022	1	2,065.57	
EFT44206	07/07/2022	MARIA IRENE GIRAK	COUNCILLOR PAYMENTS FOR JUNE 2022	1		1,905.73
INV JUNE 2 30/06/2022		MARIA IRENE GIRAK	COUNCILLOR PAYMENTS FOR JUNE 2022	1	1,905.73	
INV JUNE 2 30/06/2022		MARIA IRENE GIRAK	REVERSAL - INCORRECT PAYMENT	1	-1,905.73	
INV JUNE 2 30/06/2022		MARIA IRENE GIRAK	COUNCILLOR PAYMENTS FOR JUNE 2022	1	1,905.73	
EFT44207	07/07/2022	MICHAEL PATRICK RYAN	COUNCILLOR PAYMENTS FOR JUNE 2022	1		2,843.23
INV JUNE 2 30/06/2022		MICHAEL PATRICK RYAN	COUNCILLOR PAYMENTS FOR JUNE 2022	1	2,843.23	
INV JUNE 2 30/06/2022		MICHAEL PATRICK RYAN	REVERSAL - INCORRECT PAYMENT	1	-2,843.23	
INV JUNE 2 30/06/2022		MICHAEL PATRICK RYAN	COUNCILLOR PAYMENTS FOR JUNE 2022	1	2,843.23	
EFT44208	07/07/2022	PAUL THOMAS CURTIS	COUNCILLOR PAYMENTS FOR JUNE 2022	1		2,185.60
INV JUNE 2 30/06/2022		PAUL THOMAS CURTIS	COUNCILLOR PAYMENTS FOR JUNE 2022	1	2,015.99	

Ordinary Council Meeting Minutes  
17 August 2022



Date: 01/08/2022  
Time: 9:17:37AM

Shire of Northam

USER: Louise Harris  
PAGE: 18 10

Cheque /EFT No	Date	Name	Invoice Description	Bank Code	INV Amount	Amount
INV JUNE 2 30/06/2022		PAUL THOMAS CURTIS	REVERSAL - INCORRECT PAYMENT	1	-2,015.99	
INV JUNE 2 30/06/2022		PAUL THOMAS CURTIS	COUNCILLOR PAYMENTS FOR JUNE 2022	1	2,185.60	
EFT44209	07/07/2022	ROBERT WAYNE TINETTI	COUNCILLOR PAYMENTS FOR JUNE 2022	1		1,905.73
INV JUNE 2 30/06/2022		ROBERT WAYNE TINETTI	COUNCILLOR PAYMENTS FOR JUNE 2022	1	1,905.73	
INV JUNE 2 30/06/2022		ROBERT WAYNE TINETTI	REVERSAL - INCORRECT PAYMENT	1	-1,905.73	
INV JUNE 2 30/06/2022		ROBERT WAYNE TINETTI	COUNCILLOR PAYMENTS FOR JUNE 2022	1	1,905.73	
EFT44210	12/07/2022	AGWEST MACHINERY - GREYMACH PTY LTD T/AS	PN1904 - WUNDOWIE KUBOTA MOWER 400HR SERVICE AND REPAIRS AS PER QUOTE#38204. 01/06/2022	1		1,364.36
INV 328701	22/06/2022	AGWEST MACHINERY - GREYMACH PTY LTD T/AS	PN1904 - WUNDOWIE KUBOTA MOWER 400HR SERVICE AND REPAIRS AS PER QUOTE#38204. 01/06/2022	1	1,364.36	
EFT44211	12/07/2022	ANDY'S PLUMBING SERVICE	TOWN HALL. UNBLOCK LADIES TOILET AND REPAIR DOOR LOCK TO OTHER.	1		2,586.65
INV A19332	01/07/2022	ANDY'S PLUMBING SERVICE	MEMORIAL HALL. REPAIR LEAKING TOILET IN LADIES.	1	217.80	
INV A19335	01/07/2022	ANDY'S PLUMBING SERVICE	BERNARD PARK TOILETS. MONTHLY URINAL SERVICING - JUNE 2022	1	544.50	
INV A19331	01/07/2022	ANDY'S PLUMBING SERVICE	TOWN HALL. UNBLOCK LADIES TOILET AND REPAIR DOOR LOCK TO OTHER.	1	589.05	
INV A19333	01/07/2022	ANDY'S PLUMBING SERVICE	NORTHAM LIBRARY. UNBLOCK TOILETS.	1	429.00	
INV A19334	01/07/2022	ANDY'S PLUMBING SERVICE	BERNARD PARK TOILETS. MONTHLY URINAL SERVICING - MAY 2022	1	385.00	
INV A19330	01/07/2022	ANDY'S PLUMBING SERVICE	YOUTH PARK. REPAIR LEAKING TAP.	1	214.50	
INV A19329	01/07/2022	ANDY'S PLUMBING SERVICE	BKB. REPAIR DISHWASHER DOOR AND CHECK OPERATION.	1	206.80	
EFT44212	12/07/2022	ASHTON STEWART	REIMBURSE FOR WORKING WITH CHILDREN CHECK	1		144.60
INV 421425630	06/2022	ASHTON STEWART	REIMBURSE FOR WORKING WITH CHILDREN CHECK	1	87.00	
INV 640488	06/07/2022	ASHTON STEWART	REIMBURSEMENT OF POLICE CLEARANCE ASHTON STEWART (COMMUNITY SERVICES)	1	57.60	
EFT44213	12/07/2022	AUSTRALIA POST	AUSTRALIA POST CHARGES - JUNE 2022 - ADMIN / BKB	1		738.41

Ordinary Council Meeting Minutes  
17 August 2022



Date: 01/08/2022  
Time: 9:17:37AM

Shire of Northam

USER: Louise Harris  
PAGE: 19 13

Cheque /EFT No	Date	Name	Invoice Description	Bank Code	INV Amount	Amount
INV 101166103/07/2022		AUSTRALIA POST	AUSTRALIA POST CHARGES - JUNE 2022 - ADMIN / BKB	1	738.41	
EFT44214	12/07/2022	AUSTRALIAN SERVICES UNION	PAYROLL DEDUCTIONS	1		129.50
INV DEDUC05/07/2022		AUSTRALIAN SERVICES UNION	PAYROLL DEDUCTIONS		129.50	
EFT44215	12/07/2022	AUTOPRO NORTHAM	REPLACEMENT TOW HITCH PIN FOR PN2011	1		13.87
INV 100237301/07/2022		AUTOPRO NORTHAM	REPLACEMENT TOW HITCH PIN FOR PN2011	1	13.87	
EFT44216	12/07/2022	AVON VALLEY BAKERY	250 NAIDOC THEMED CUPCAKES-EVENT 07/07/2022	1		450.00
INV INV-09607/07/2022		AVON VALLEY BAKERY	250 NAIDOC THEMED CUPCAKES-EVENT 07/07/2022	1	450.00	
EFT44217	12/07/2022	AVON VALLEY PLANT & EQUIPMENT PTY LTD	SIEVE ROCKS AND PLACE AS PER DRAWING TO DISCOURAGE TRAFFIC. NO MOB/DEMOB AS MACHINE ON SITE	1		1,980.00
INV IV1085428/06/2022		AVON VALLEY PLANT & EQUIPMENT PTY LTD	SIEVE ROCKS AND PLACE AS PER DRAWING TO DISCOURAGE TRAFFIC. NO MOB/DEMOB AS MACHINE ON SITE	1	1,980.00	
EFT44218	12/07/2022	BAKERS HILL RURAL SUPPLIES & HARDWARE	BLUELINE 40MM FITTINGS	1		120.00
INV 171524	05/07/2022	BAKERS HILL RURAL SUPPLIES & HARDWARE	BLUELINE 40MM FITTINGS	1	87.00	
INV 171555	06/07/2022	BAKERS HILL RURAL SUPPLIES & HARDWARE	REPLACEMENT GAS BOTTLE	1	33.00	
EFT44219	12/07/2022	BANDIT TREE EQUIPMENT	U BOLT 9/16" X 95MM X200MM / LEAF SPRING FOR 8K AXLE	1		1,465.09
INV 1281W	29/06/2022	BANDIT TREE EQUIPMENT	U BOLT 9/16" X 95MM X200MM / LEAF SPRING FOR 8K AXLE	1	1,465.09	
EFT44220	12/07/2022	BIG BUBBLE RETAIL	CANE FOR WAGAL STREET PARADE PUPPET	1		262.20
INV 14461	27/06/2022	BIG BUBBLE RETAIL	CANE FOR WAGAL STREET PARADE PUPPET	1	262.20	
EFT44221	12/07/2022	BUILDER'S REGISTRATION BOARD OF WA	MONTHLY BSL FEES COLLECTED FOR THE BUILDING COMMISSION FOR THE MONTH OF JUNE 2022	1		5,733.71
INV T1080	08/07/2022	BUILDER'S REGISTRATION BOARD OF WA	MONTHLY BSL FEES COLLECTED FOR THE BUILDING COMMISSION FOR THE MONTH OF JUNE 2022	1	5,733.71	

Ordinary Council Meeting Minutes  
17 August 2022



Date: 01/08/2022  
Time: 9:17:37AM

Shire of Northam

USER: Louise Harris  
PAGE: 20 10

Cheque /EFT No	Date	Name	Invoice Description	Bank Code	INV Amount	Amount
EFT44222	12/07/2022	BUILDING AND CONSTRUCTION INDUSTRY TRAINING FUND	MONTHLY BCITF FEES COLLECTED FOR THE CONSTRUCTION TRAINING FUND FOR THE MONTH OF JUNE 2022	1		512.89
INV T1079	08/07/2022	BUILDING AND CONSTRUCTION INDUSTRY TRAINING FUND	MONTHLY BCITF FEES COLLECTED FOR THE CONSTRUCTION TRAINING FUND FOR THE MONTH OF JUNE 2022	1	512.89	
EFT44223	12/07/2022	BUNNINGS BUILDING SUPPLIES P/L	FIRE EXTINGUISHER	1		85.24
INV 2182/0027/06/2022		BUNNINGS BUILDING SUPPLIES P/L	CABLE TIES	1	20.64	
INV 2182/0001/07/2022		BUNNINGS BUILDING SUPPLIES P/L	FIRE EXTINGUISHER	1	64.60	
EFT44224	12/07/2022	CADDS FASHIONS	SHIRTS / PANTS	1		695.20
INV 22-000009/06/2022		CADDS FASHIONS	UNIFORMS - LOUISE DYER	1	140.30	
INV 22-000030/06/2022		CADDS FASHIONS	WORKBOOT ALLOWANCE - RUSSELL PUTRINO	1	170.00	
INV 22-000006/07/2022		CADDS FASHIONS	SHIRTS / PANTS	1	384.90	
EFT44225	12/07/2022	CHILD SUPPORT AGENCY	PAYROLL DEDUCTIONS	1		138.85
INV DEDUC05/07/2022		CHILD SUPPORT AGENCY	PAYROLL DEDUCTIONS		138.85	
EFT44226	12/07/2022	CONTRAFLOW PTY LTD	TRAFFIC MANAGEMENT PLAN AMENDMENT FEE - AVON DESCENT BILYA FESTIVAL 2022	1		165.62
INV T18/68718/03/2022		CONTRAFLOW PTY LTD	TRAFFIC MANAGEMENT PLAN AMENDMENT FEE - AVON DESCENT BILYA FESTIVAL 2022	1	165.62	
EFT44227	12/07/2022	COUNTRY COMFORTSTYLE NORTHAM	BROOM CUPBOARD	1		384.00
INV 17458 27/06/2022		COUNTRY COMFORTSTYLE NORTHAM	BROOM CUPBOARD	1	384.00	
EFT44228	12/07/2022	COUNTRY COPIERS NORTHAM	89X62 AVERY LABELS	1		214.55
INV 45113 30/06/2022		COUNTRY COPIERS NORTHAM	89X62 AVERY LABELS	1	98.00	
INV 45113 30/06/2022		COUNTRY COPIERS NORTHAM	1 X FINANCIAL YEAR DIARY	1	35.70	
INV 45113 30/06/2022		COUNTRY COPIERS NORTHAM	FINANCIAL YEAR DIARY 2 DAYS PER PAGE BINDING SPIRALS (VARIETY OF SIZES) PLASTIC COVERS FOR BINDING DOCUMENTS	1	80.85	

Ordinary Council Meeting Minutes  
17 August 2022



Date: 01/08/2022  
Time: 9:17:37AM

Shire of Northam

USER: Louise Harris  
PAGE: 21/13

Cheque /EFT No	Date	Name	Invoice Description	Bank Code	INV Amount	Amount
EFT44229	12/07/2022	DCM CARPENTRY & MAINTENANCE	REC CENTRE STADIUM ROOF LEAK	1		3,020.60
INV 1407	26/06/2022	DCM CARPENTRY & MAINTENANCE	REPAIR TO TURNSTILE - ADD GARRISEN POLE	1	459.80	
INV 1410	26/06/2022	DCM CARPENTRY & MAINTENANCE	REC CENTRE STADIUM ROOF LEAK	1	1,466.30	
INV 1409	26/06/2022	DCM CARPENTRY & MAINTENANCE	FIRST AID ROOM LEAKS (NEW FIRST AID ROOM NEAR MAIN OFFICE)	1	819.50	
INV 1412	28/06/2022	DCM CARPENTRY & MAINTENANCE	BARBS FOR REPAIRS TO SOLAR PANELS - NORTHAM POOL	1	275.00	
EFT44230	12/07/2022	DEBORAH MOODY	WTC PERFORMED BY DEBORAH MOODY @ BIL YA KOORT BOODJA CENTRE FOR POLICE MEETING ON THE 20TH OF JUNE 2022	1		300.00
INV 22	20/06/2022	DEBORAH MOODY	WTC PERFORMED BY DEBORAH MOODY @ BIL YA KOORT BOODJA CENTRE FOR POLICE MEETING ON THE 20TH OF JUNE 2022	1	300.00	
EFT44231	12/07/2022	DEPARTMENT OF WATER & ENVIRONMENT REGULATION	DWER QUARTERLY LEVY RETURN; APRIL - JUNE 2022	1		12,072.42
INV JJ 0807208/07/2022		DEPARTMENT OF WATER & ENVIRONMENT REGULATION	DWER QUARTERLY LEVY RETURN; APRIL - JUNE 2022	1	12,072.42	
EFT44232	12/07/2022	EASIFLEET	PAYROLL DEDUCTIONS	1		1,853.35
INV DEDUC05/07/2022		EASIFLEET	PAYROLL DEDUCTIONS		1,054.26	
INV DEDUC05/07/2022		EASIFLEET	PAYROLL DEDUCTIONS		799.09	
EFT44233	12/07/2022	GLENN STUART BEVERIDGE	POND 3 PERIMETER FENCING REMOVED / POND 3 PERIMETER FENCING REPLACED	1		3,850.00
INV 322	09/06/2022	GLENN STUART BEVERIDGE	POND 3 PERIMETER FENCING REMOVED / POND 3 PERIMETER FENCING REPLACED	1	3,850.00	
EFT44234	12/07/2022	JACKSON HARVEY	BEAVIS PLACE MURAL - 3 INTERCHANGEABLE ARTWORKS 1.5x2.15M DESIGN FEE	1		10,990.00
INV 170620217/06/2022		JACKSON HARVEY	BEAVIS PLACE MURAL - 3 INTERCHANGEABLE ARTWORKS 1.5x2.15M DESIGN FEE	1	10,990.00	



Date: 01/08/2022  
Time: 9:17:37AM

Shire of Northam

USER: Louise Harris  
PAGE: 22 10

Cheque /EFT No	Date	Name	Invoice Description	Bank Code	INV Amount	Amount
EFT44235	12/07/2022	JLO DESIGNS	JULY SCHOOL HOLIDAY POSTER DESIGN 2022	1		65.00
INV 478	28/06/2022	JLO DESIGNS	JULY SCHOOL HOLIDAY POSTER DESIGN 2022	1	65.00	
EFT44236	12/07/2022	JOMAR WA PTY LTD	PROPPING OF BRIDGE 0610 AS PER MRWA REQUIREMENTS	1		12,265.00
INV IN0269	30/06/2022	JOMAR WA PTY LTD	PROPPING OF BRIDGE 0610 AS PER MRWA REQUIREMENTS	1	12,265.00	
EFT44237	12/07/2022	KIRK GARLETT	SALE OF ARTWORK (KIRK GARLETT)	1		1,000.00
INV 8	27/06/2022	KIRK GARLETT	SALE OF ARTWORK (KIRK GARLETT)	1	1,000.00	
EFT44238	12/07/2022	KUDZAIMATANGA	KUDZAIMATANGA RELOCATION EXPENSES - REMOVALIST / STORAGE BOXES / FUEL	1		1,641.98
INV AR 010701	07/2022	KUDZAIMATANGA	REIMBURSEMENT OF POLICE CLEARANCE & MEDICALS (SPIROMETRY & MEDICAL)	1	376.60	
INV CY 040704	07/2022	KUDZAIMATANGA	KUDZAIMATANGA (SENIOR ACCOUNTANT) KUDZAIMATANGA RELOCATION EXPENSES - REMOVALIST / STORAGE BOXES / FUEL	1	1,265.38	
EFT44239	12/07/2022	MAJOR MOTORS	FLOOR MATS FOR ISUZU NPR 65/45-190 CREW TIPPER TRUCK	1		99.28
INV 122527907	07/2022	MAJOR MOTORS	FLOOR MATS FOR ISUZU NPR 65/45-190 CREW TIPPER TRUCK	1	99.28	
EFT44240	12/07/2022	NINTEX PTY LTD	SOFTWARE - PROCESS MAPPING, RISK & COMPLIANCE MANAGEMENT, IMPROVEMENT & INCIDENT MANAGEMENT	1		31,059.60
INV INV598	14/06/2022	NINTEX PTY LTD	SOFTWARE - PROCESS MAPPING, RISK & COMPLIANCE MANAGEMENT, IMPROVEMENT & INCIDENT MANAGEMENT	1	31,059.60	
EFT44241	12/07/2022	NORTH METROPOLITAN TAFE	AHCMOM213 - OPERATE AND MAINTAIN CHAINSAWS. NORTH METRO TAFE MIDLAND - RILEY BLANKENDAAL / DANICA BRADFORD	1		283.40

Ordinary Council Meeting Minutes  
17 August 2022



Date: 01/08/2022  
Time: 9:17:37AM

Shire of Northam

USER: Louise Harris  
PAGE: 23 13

Cheque /EFT No	Date	Name	Invoice Description	Bank Code	INV Amount	Amount
INV I00332330/06/2022		NORTH METROPOLITAN TAFE	DANICA BRADFORD / RILEY BLANKENDAAL - SEMESTER 2 2022	1	130.00	
INV I00332930/06/2022		NORTH METROPOLITAN TAFE	AHCNSY306 - IMPLEMENT A PROPAGATION PLAN AHCPCM301 - IMPLEMENT A PLANT NUTRITION PR AHCSOL303 - IMPLEMENT SOIL IMPROVEMENTS FO AHCMMOM213 - OPERATE AND MAINTAIN CHAINSAWS. NORTH METRO TAFE MIDLAND - RILEY BLANKENDAAL / DANICA BRADFORD	1	153.40	
EFT44242	12/07/2022	NORTHAM CHAMBER OF COMMERCE	BILYA FESTIVAL FULL PAGE AD- JULY 2022	1		1,061.50
INV 000003628/06/2022		NORTHAM CHAMBER OF COMMERCE	BILYA FESTIVAL FULL PAGE AD- JULY 2022	1	440.00	
INV 000003728/06/2022		NORTHAM CHAMBER OF COMMERCE	AD IN JULY ADVERTISER- DISPOSAL OF UNIT BY LEASE	1	181.50	
INV 000003728/06/2022		NORTHAM CHAMBER OF COMMERCE	SHIRE INCLUSION IN NORTHAM ADVERTISER- FULL PAGE- JULY 2022	1	440.00	
EFT44243	12/07/2022	NORTHAM FEED & HIRE	6X ANIMAL CAGES	1		1,424.00
INV 000042423/05/2022		NORTHAM FEED & HIRE	6X ANIMAL CAGES	1	1,380.00	
INV 000042924/06/2022		NORTHAM FEED & HIRE	SWAN FOOD & OTHER MISCELLANEOUS ITEMS TILL 30/06/2022	1	44.00	
EFT44244	12/07/2022	NORTHAM RAILWAYS FOOTBALL CLUB INC	2021/22 QUICK RESPONSE GRANT PAYMENT - NAIDOC FOOTBALL GAME	1		2,900.00
INV 2022-2422/06/2022		NORTHAM RAILWAYS FOOTBALL CLUB INC	2021/22 QUICK RESPONSE GRANT PAYMENT - NAIDOC FOOTBALL GAME	1	2,900.00	
EFT44245	12/07/2022	NUTRIEN AG SOLUTIONS LIMITED	PANZER 450 (GLYPHOSATE) 5 x 20L / TRIMAC WDG 5 x 5KG BOXES	1		6,270.95
INV 907078409/06/2022		NUTRIEN AG SOLUTIONS LIMITED	PANZER 450 (GLYPHOSATE) 5 x 20L / TRIMAC WDG 5 x 5KG BOXES	1	5,387.25	
INV 907077909/06/2022		NUTRIEN AG SOLUTIONS LIMITED	FN2103 - CAM LOCK FITTINGS	1	95.82	
INV 907078409/06/2022		NUTRIEN AG SOLUTIONS LIMITED	REPLACEMENT GAS BOTTLE FOR PN1405 FORKLIFT	1	61.88	
INV 907182327/06/2022		NUTRIEN AG SOLUTIONS LIMITED	20L DRUMS OF PANZER 450 GYLSOPHATE	1	726.00	
EFT44246	12/07/2022	OXTER SERVICES	12 OZ INDIG CUPS / WHITE PAPAER / FOOD CONTAINERS -NAIDOC	1		89.48

Ordinary Council Meeting Minutes  
17 August 2022



Date: 01/08/2022  
Time: 9:17:37AM

Shire of Northam

USER: Louise Harris  
PAGE: 24 10

Cheque /EFT No	Date	Name	Invoice Description	Bank Code	INV Amount	Amount
INV 26007	06/07/2022	OXTER SERVICES	12 OZ INDIG CUPS / WHITE PAPAER / FOOD CONTAINERS -NAIDOC	1	89.48	
EFT44247	12/07/2022	ROD QUIN AND ASSOCIATES - RODNEY QUIN T/AS	ROD QUIN BOOKS THE LIFE AND TIMES OF JOHN BEAZELEY	1		59.80
INV 280620228/06/2022		ROD QUIN AND ASSOCIATES - RODNEY QUIN T/AS	ROD QUIN BOOKS THE LIFE AND TIMES OF JOHN BEAZELEY	1	59.80	
EFT44248	12/07/2022	ROYAL LIFE SAVING SOCIETY WA	WUNDOWIE POOL CONDITIONS OF ENTRY SIGNAGE	1		434.50
INV 172339	29/06/2022	ROYAL LIFE SAVING SOCIETY WA	WUNDOWIE POOL CONDITIONS OF ENTRY SIGNAGE	1	434.50	
EFT44249	12/07/2022	SOUTHERN CROSS AUSTEREO PTY LTD	522 X 30 2 PER DAY SECOND RADIO COMMERCIALS ON TRIPLE M, NORTHAM	1		1,313.40
INV 713424830/06/2022		SOUTHERN CROSS AUSTEREO PTY LTD	522 X 30 2 PER DAY SECOND RADIO COMMERCIALS ON HIT FM NORTHAM AND MERREDIN PLUS MAXIMUM BONUS FILL ON BOTH STATIONS JUNE 2022	1	1,313.40	
EFT44250	12/07/2022	SPECIALISED TREE SERVICE	VEGETATION CLEARING 0612 BRIDGE PEEL TERRACE	1		2,006.40
INV 3882	30/06/2022	SPECIALISED TREE SERVICE	VEGETATION CLEARING 0612 BRIDGE PEEL TERRACE	1	2,006.40	
EFT44251	12/07/2022	SPORTSPOWER NORTHAM H & H JOUBERT	WUNDOWIE POOL UNIFORMS	1		2,557.50
INV 22-000030/06/2022		SPORTSPOWER NORTHAM H & H JOUBERT	NORTHAM POOL UNIFORMS	1	1,020.50	
INV 22-000030/06/2022		SPORTSPOWER NORTHAM H & H JOUBERT	WUNDOWIE POOL UNIFORMS	1	1,138.00	
INV 22-000005/07/2022		SPORTSPOWER NORTHAM H & H JOUBERT	NAVY VENTED BRIM HATS	1	399.00	
EFT44252	12/07/2022	SWIFT OFFICE SOLUTIONS PTY LTD	BKB - PRINTER INK CARTRIDGES	1		255.90
INV 37678	17/05/2022	SWIFT OFFICE SOLUTIONS PTY LTD	BKB - PRINTER INK CARTRIDGES	1	255.90	

Ordinary Council Meeting Minutes  
17 August 2022



Date: 01/08/2022  
Time: 9:17:37AM

Shire of Northam

USER: Louise Harris  
PAGE: 25 13

Cheque /EFT No	Date	Name	Invoice Description	Bank Code	INV Amount	Amount
EFT44253	12/07/2022	SYNERGY	811029470 WUNDOWIE SWIMMING POOL - 29/04/2022 to 28/06/2022	1		12,970.89
INV 135846505/01/2022		SYNERGY	BAKERS HILL FIRE STATION - NOV 2021 TO JAN 2022	1	339.02	
INV 135846504/03/2022		SYNERGY	BAKERS HILL FIRE STATION - JAN 2022 TO MAR 2022	1	407.42	
INV 135846505/05/2022		SYNERGY	BAKERS HILL FIRE STATION - MAR 2022 TO MAY 2022	1	349.18	
INV 796841316/06/2022		SYNERGY	796841340 SHIRE ADMINISTRATION BUILDING - 19/05/2022 to 15/06/2022		661.85	
INV 136537716/06/2022		SYNERGY	136537740 AIRPORT - 19/05/2022 to 15/06/2022		1,120.16	
INV 361670216/06/2022		SYNERGY	361670250 NORTHAM LIBRARY - 19/05/2022 to 15/06/2022		394.11	
INV 357549616/06/2022		SYNERGY	357549690 KILLARA DAYCARE CENTRE - COTTAGE - 19/05/2022 to 15/06/2022		1,058.31	
INV 361669521/06/2022		SYNERGY	361669500 OXIDATION PONDS - 17/05/2022 to 20/06/2022		2,320.66	
INV 361990029/06/2022		SYNERGY	361990030 WUNDOWIE OVAL - 28/04/2022 to 28/06/2022		250.91	
INV 916822729/06/2022		SYNERGY	916822750 WUNDOWIE TENNIS CLUB - 29/04/2022 to 28/06/2022		114.50	
INV 332273629/06/2022		SYNERGY	332273630 CLACKLINE POST OFFICE - 27/04/2022 to 24/06/2022		293.29	
INV 142275929/06/2022		SYNERGY	142275950 WUNDOWIE OVAL - 29/04/2022 to 28/06/2022		452.32	
INV 288626729/06/2022		SYNERGY	288626740 CLACKLINE HALL - 27/04/2022 to 27/06/2022		127.90	
INV 164007729/06/2022		SYNERGY	164007710 WUNDOWIE DEPOT - 29/04/2022 to 28/06/2022		435.13	
INV 160396129/06/2022		SYNERGY	160396120 CLACKLINE FIRE SHED - 27/04/2022 to 24/06/2022		203.97	
INV 981292530/06/2022		SYNERGY	981292570 BAKERS HILL REC CENTRE - 30/04/2022 to 27/06/2022		851.18	
INV 811029430/06/2022		SYNERGY	811029470 WUNDOWIE SWIMMING POOL - 29/04/2022 to 28/06/2022		2,527.13	
INV 300677001/07/2022		SYNERGY	300677070 WUNDOWIE FOOTBALL PAVILLION - 04/05/2022 to 30/06/2022		261.04	
INV 962642901/07/2022		SYNERGY	962642990 WUNDOWIE MEDICAL CENTRE - 04/05/2022 to 30/06/2022		108.87	
INV 305307601/07/2022		SYNERGY	305307610 AGED ACCOMMODATION WUNDOWIE - 04/05/2022 to 30/06/2022		43.11	

Ordinary Council Meeting Minutes  
17 August 2022



Date: 01/08/2022  
Time: 9:17:37AM

Shire of Northam

USER: Louise Harris  
PAGE: 26 10

Cheque /EFT No	Date	Name	Invoice Description	Bank Code	INV Amount	Amount
INV 370639201	07/2022	SYNERGY	370639230 WUNDOWIE TOWN HALL - 04/05/2022 to 30/06/2022		121.43	
INV 487964001	07/2022	SYNERGY	487964040 WUNDOWIE YAK SHACK - 04/05/2022 to 30/06/2022		110.33	
INV 158509704	07/2022	SYNERGY	158509760 BAKERS HILL BFB FIRE SHED - 27/04/2022 to 27/06/2022		130.39	
INV 135846505	07/2022	SYNERGY	BAKERS HILL FIRE STATION - APR 2022 TO JUNE 2022	1	288.68	
EFT44254	12/07/2022	TENNANT AUSTRALIA	REPAIRS TO T1B FLOOR CLEANING UNIT	1		642.18
INV 918838901	07/2022	TENNANT AUSTRALIA	REPAIRS TO T1B FLOOR CLEANING UNIT	1	642.18	
EFT44255	12/07/2022	THE PRINT SHOP BUNBURY	2000X NORTHAM VISITOR GUIDES FULL COLOUR, DOUBLE SIDED, MATTE FINISH, FOLDED	1		1,469.60
INV 151269005	07/2022	THE PRINT SHOP BUNBURY	2000X NORTHAM VISITOR GUIDES FULL COLOUR, DOUBLE SIDED, MATTE FINISH, FOLDED	1	1,469.60	
EFT44256	12/07/2022	THINKPROJECT AUSTRALIA PTY LTD T-AS RAMM SOFTWARE PTY LTD	RENTAL OF THE POCKET RAMM SOFTWARE FOR THE PERIOD 01 JUL 2021 TO 30 JUN 2022. THIS RENTAL ALLOWS YOU TO USE THIS SOFTWARE FOR ANY NUMBER OF CONTRACTS BUT ONLY ON EACH NAMED DEVICE THAT YOU HAVE PURCHASED. THIS IS NOT A CONCURRENT USER LICENSE AS EACH DEVICE MUST HAVE A LICENSE TO USE THE POCKET SOFTWARE / RAMM ANNUAL SUPPORT & MAINTENANCE FEE FOR THE PERIOD 01/07/2022-30/06/2023	1		10,943.54
INV RSL-18	01/07/2022	THINKPROJECT AUSTRALIA PTY LTD T-AS RAMM SOFTWARE PTY LTD	RENTAL OF THE POCKET RAMM SOFTWARE FOR THE PERIOD 01 JUL 2021 TO 30 JUN 2022. THIS RENTAL ALLOWS YOU TO USE THIS SOFTWARE FOR ANY NUMBER OF CONTRACTS BUT ONLY ON EACH NAMED DEVICE THAT YOU HAVE PURCHASED. THIS IS NOT A CONCURRENT USER LICENSE AS EACH DEVICE MUST HAVE A LICENSE TO USE THE POCKET SOFTWARE / RAMM ANNUAL SUPPORT & MAINTENANCE FEE FOR THE PERIOD 01/07/2022-30/06/2023	1	10,943.54	
EFT44257	12/07/2022	TOLL - IPEC PTY LTD T/AS	TOLL FREIGHT CHARGES TO 03/04/2022 - CESM / HEALTH / LIBRARY / DEPOT	1		129.68

Ordinary Council Meeting Minutes  
17 August 2022



Date: 01/08/2022  
Time: 9:17:37AM

Shire of Northam

USER: Louise Harris  
PAGE: 27 13

Cheque /EFT No	Date	Name	Invoice Description	Bank Code	INV Amount	Amount
INV 0538-S303/04/2022		TOLL - IPEC PTY LTD T/AS	TOLL FREIGHT CHARGES TO 03/04/2022 - CESM / HEALTH / LIBRARY / DEPOT	1	85.79	
INV 0547-S305/06/2022		TOLL - IPEC PTY LTD T/AS	TOLL FREIGHT CHARGES - 05 JUNE 2022 - CESM / DEPOT	1	43.89	
EFT44258	12/07/2022	TREVOR EASTWELL	DRIVING FOR WUNDOWIE TO NORTHAM COMMUNITY TRANSPORT 23/06/2022	1		100.00
INV 94	07/07/2022	TREVOR EASTWELL	DRIVING FOR WUNDOWIE TO NORTHAM COMMUNITY TRANSPORT 23/06/2022	1	50.00	
INV 95	07/07/2022	TREVOR EASTWELL	DRIVING FOR WUNDOWIE TO NORTHAM COMMUNITY TRANSPORT 7 JULY 2022	1	50.00	
EFT44259	12/07/2022	TYREPOWER LTD	REPAIR REAR VEHICLE TYRE THAT IS GOING FLAT	1		31.08
INV 8265-1422/06/2022		TYREPOWER LTD	REPAIR REAR VEHICLE TYRE THAT IS GOING FLAT	1	31.08	
EFT44260	12/07/2022	WA RETICULATION SUPPLIES	RETICULATION ELBOW 63MM TO 50MM	1		35.46
INV M5467 04/05/2022		WA RETICULATION SUPPLIES	RETICULATION ELBOW 63MM TO 50MM	1	35.46	
EFT44261	12/07/2022	WAY SIGNS	6X1200 MM WIDE X 800 MM EXTERIOR HIGH METAL SIGNS FOR THE INKPEN TIP - SOLID BLACK TEXT AND SOLID YELLOW ARROWS - TIP FACE, GREEN WASTE, SCRAP METAL, ETC. \$198 EACH INCL. GST.	1		1,188.00
INV INV-29024/04/2022		WAY SIGNS	6X1200 MM WIDE X 800 MM EXTERIOR HIGH METAL SIGNS FOR THE INKPEN TIP - SOLID BLACK TEXT AND SOLID YELLOW ARROWS - TIP FACE, GREEN WASTE, SCRAP METAL, ETC. \$198 EACH INCL. GST.	1	1,188.00	
EFT44262	12/07/2022	WESTERN AUSTRALIAN LOCAL GOVERNMENT ASSOCIATION	INTRODUCTION TO PLANNING (ELEARNING) BOBBI-JO WISE	1		214.50
INV I30934426/05/2022		WESTERN AUSTRALIAN LOCAL GOVERNMENT ASSOCIATION	INTRODUCTION TO PLANNING (ELEARNING) BOBBI-JO WISE	1	214.50	
EFT44263	12/07/2022	WESTWIDE AUTO ELECTRICS AND AIR CONDITIONING	FN1805 - TEST, SUPPLY AND REPLACE ISOLATOR TO RESPONSE TRUCK	1		880.70
INV INV-13714/06/2022		WESTWIDE AUTO ELECTRICS AND AIR CONDITIONING	FN1511 - REPLACE BATTERY	1	405.70	
INV INV-13730/06/2022		WESTWIDE AUTO ELECTRICS AND AIR CONDITIONING	FN1805 - TEST, SUPPLY AND REPLACE ISOLATOR TO RESPONSE TRUCK	1	475.00	

Ordinary Council Meeting Minutes  
17 August 2022



Date: 01/08/2022  
Time: 9:17:37AM

Shire of Northam

USER: Louise Harris  
PAGE: 28 10

Cheque /EFT No	Date	Name	Invoice Description	Bank Code	INV Amount	Amount
EFT44264	12/07/2022	WREN OIL	ATTEND OLD QUARRY TIP SITE EMPTY WASTE OIL	1		16.50
INV 133348	28/06/2022	WREN OIL	CHARGES FOR ADMIN & COMPLIANCE FEES ATTEND OLD QUARRY TIP SITE EMPTY WASTE OIL CHARGES FOR ADMIN & COMPLIANCE FEES	1	16.50	
EFT44265	14/07/2022	ADEPT PHOTO BOOTHS - COLIN RICHARDSON T/AS	WORKSHOP - SEVEN STEPS TO SPONSORSHIP SUCCESS	1		596.82
INV 000013727	05/2022	ADEPT PHOTO BOOTHS - COLIN RICHARDSON T/AS	WORKSHOP - SEVEN STEPS TO SPONSORSHIP SUCCESS	1	596.82	
EFT44266	14/07/2022	AMPAC DEBT RECOVERY (WA) P/L	DEBT COLLECTION FOR PERIOD ENDING JUNE 2022	1		503.25
INV 85426	30/06/2022	AMPAC DEBT RECOVERY (WA) P/L	DEBT COLLECTION FOR PERIOD ENDING JUNE 2022	1	503.25	
EFT44267	14/07/2022	ANDREW DAMIEN SMITH	RATES CREDIT REFUND FOR ASSESSMENT A15505	1		2,175.96
INV A15505	14/07/2022	ANDREW DAMIEN SMITH	RATES CREDIT REFUND FOR ASSESSMENT A15505		2,175.96	
EFT44268	14/07/2022	ASTROTOURISM WA PTY LTD	ASTRO PHOTOGRAPHY WORKSHOP - 21 APRIL 2022 PROMOTIONAL POSTER & 2 ASTRO TOURISM STAFF	1		2,750.00
INV 1137	22/04/2022	ASTROTOURISM WA PTY LTD	ASTRO PHOTOGRAPHY WORKSHOP - 21 APRIL 2022 PROMOTIONAL POSTER & 2 ASTRO TOURISM STAFF	1	2,750.00	
EFT44269	14/07/2022	AUSTRALIAN TAXATION OFFICE - PAYG	PAYG FOR PAY WEEK ENDING 05/7/2022	1		61,655.32
INV PAYG 008	07/2022	AUSTRALIAN TAXATION OFFICE - PAYG	PAYG FOR PAY WEEK ENDING 05/7/2022	1	61,655.32	
EFT44270	14/07/2022	AVON WASTE	MANAGEMENT AT INKPEN LANDFILL FACILITY - JUNE 2022	1		16,044.60
INV 000509230	06/2022	AVON WASTE	MANAGEMENT AT INKPEN LANDFILL FACILITY - JUNE 2022	1	16,044.60	
EFT44271	14/07/2022	BUSINESS FUEL CARDS PTY LTD (FLEET CARD)	FUEL CHARGES FOR JUNE 2022	1		402.98
INV JUNE 2	30/06/2022	BUSINESS FUEL CARDS PTY LTD (FLEET CARD)	FUEL CHARGES FOR JUNE 2022	1	402.98	
EFT44272	14/07/2022	CENTRAL MOBILE MECHANICAL REPAIRS	PICK UP STEEL DRUM ROLLER FROM NORTHAM DEPOT AND DROP OFF AT PARKER ROAD	1		709.50

Ordinary Council Meeting Minutes  
17 August 2022



Date: 01/08/2022  
Time: 9:17:37AM

Shire of Northam

USER: Louise Harris  
PAGE: 29 13

Cheque /EFT No	Date	Name	Invoice Description	Bank Code	INV Amount	Amount
INV 000040302/06/2022		CENTRAL MOBILE MECHANICAL REPAIRS	PICK UP STEEL DRUM ROLLER FROMNORTHAM DEPOT AND DROP OFF AT PARKER ROAD	1	709.50	
EFT44273	14/07/2022	CLIFFORD JOHN MCLACHLAN	RATES CREDIT REFUND FOR ASSESSMENT A2163	1		736.85
INV A2163	14/07/2022	CLIFFORD JOHN MCLACHLAN	RATES CREDIT REFUND FOR ASSESSMENT A2163		736.85	
EFT44274	14/07/2022	CRYSTAL PRINTING SOLUTIONS PTY LTD T/A WORLWIDE EAST PERTH	2022-23 RESIDENTIAL TIP PASS	1		1,144.00
INV 109769428/06/2022		CRYSTAL PRINTING SOLUTIONS PTY LTD T/A WORLWIDE EAST PERTH	2022-23 RESIDENTIAL TIP PASS	1	1,144.00	
EFT44275	14/07/2022	CYNDY MOODY	CYNDY MOODY FOR NAIDOC PERFORMANCE DONE @ BIL YA KOORT BOODJA 07-07-2022	1		1,000.00
INV 069	28/06/2022	CYNDY MOODY	CYNDY MOODY FOR NAIDOC PERFORMANCE DONE @ BIL YA KOORT BOODJA 07-07-2022	1	1,000.00	
EFT44276	14/07/2022	DCM CARPENTRY & MAINTENANCE	TOWN HALL. REPLACE ARCH DOOR TO THE TOP OF STAIRS.	1		1,580.70
INV 1415	27/06/2022	DCM CARPENTRY & MAINTENANCE	TOWN HALL. REPLACE ARCH DOOR TO THE TOP OF STAIRS.	1	988.90	
INV 1416	28/06/2022	DCM CARPENTRY & MAINTENANCE	SUSPENSION BRIDGE. REPLACE BROKEN BOARD NEAR BKB END.	1	327.80	
INV 1418	05/07/2022	DCM CARPENTRY & MAINTENANCE	KILLARA RESIT CARE. REPAIR TO SLIDING DOOR TO DINING ROOM AFTER FRIDAY NIGHT BREAK IN.	1	192.50	
INV 1417	05/07/2022	DCM CARPENTRY & MAINTENANCE	NORTHAM DEPOT. REPAIR ENTRY DOOR.	1	71.50	
EFT44277	14/07/2022	DEBORAH MOODY	DEBORAH MOODY FOR WELCOMING FAMILY TO NAIDOC @ BIL YA KOORT BOODJA 07-07-2022	1		300.00
INV 1	07/07/2022	DEBORAH MOODY	DEBORAH MOODY FOR WELCOMING FAMILY TO NAIDOC @ BIL YA KOORT BOODJA 07-07-2022	1	300.00	



Ordinary Council Meeting Minutes  
17 August 2022



Date: 01/08/2022  
Time: 9:17:37AM

Shire of Northam

USER: Louise Harris  
PAGE: 30 10

Cheque /EFT No	Date	Name	Invoice Description	Bank Code	INV Amount	Amount
EFT44278	14/07/2022	DMC CLEANING	CLEANING OF NORTHAM FACILITES - CONSUMABLE PRODUCTS - 01/06/2022	1		1,467.65
INV SON20828/06/2022		DMC CLEANING	CLEANING OF NORTHAM FACILITES - CONSUMABLE PRODUCTS - 01/06/2022	1	1,099.18	
INV SON20904/07/2022		DMC CLEANING	CLEANING SHIRE OF NORTHAM FACILITES - CONSUMABLE PRODUCTS PROVIDED - 28/06/2022	1	368.47	
EFT44279	14/07/2022	DUN DIRECT PTY LTD	FUEL CHARGES FOR JUNE 2022	1		34,668.72
INV JUNE 2 30/06/2022		DUN DIRECT PTY LTD	FUEL CHARGES FOR JUNE 2022	1	34,668.72	
EFT44280	14/07/2022	E FIRE & SAFETY	MONTHLY ROUTINE MAINTENANCE CHARGES FOR THE TESTING OF THE FIRE DETECTION SYSTEM AT NORTHAM TOWN HALL 01/06/2022 - 30/06/2022	1		162.80
INV 566577 30/06/2022		E FIRE & SAFETY	MONTHLY ROUTINE MAINTENANCE CHARGES FOR THE TESTING OF THE FIRE DETECTION SYSTEM AT NORTHAM TOWN HALL 01/06/2022 - 30/06/2022	1	162.80	
EFT44281	14/07/2022	EQUIFAX AUSTRALASIA WORKFORCE SOLUTIONS PTY LTD	INDIVIDUAL REPORTS FOR NEW VOLUNTEER FIREFIGHTING MEMBERS - JUNE 2022	1		400.07
INV 150916231/03/2022		EQUIFAX AUSTRALASIA WORKFORCE SOLUTIONS PTY LTD	INDIVIDUAL REPORTS FOR NEW VOLUNTEER FIREFIGHTING MEMBERS - MARCH 2022	1	125.07	
INV 151536830/06/2022		EQUIFAX AUSTRALASIA WORKFORCE SOLUTIONS PTY LTD	INDIVIDUAL REPORTS FOR NEW VOLUNTEER FIREFIGHTING MEMBERS - JUNE 2022	1	275.00	
EFT44282	14/07/2022	EQUITY SETTLEMENTS	RATES CREDIT REFUND FOR ASSESSMENT A12579	1		603.61
INV A12579 14/07/2022		EQUITY SETTLEMENTS	RATES CREDIT REFUND FOR ASSESSMENT A12579		603.61	
EFT44283	14/07/2022	FINISHING WA	BINDING OF COUNCIL MINUTES	1		1,213.30
INV INV -16730/06/2022		FINISHING WA	BINDING OF COUNCIL MINUTES	1	1,213.30	
EFT44284	14/07/2022	FRANK DAVIS	WTC + DIDGERIDOO PLAY + STORY TELLING DONE BY FRANK DAVIS FOR GROWER GROUP ALLIANCE ON 28-06-2022	1		1,500.00
INV 11 28/06/2022		FRANK DAVIS	WTC + DIDGERIDOO PLAY + STORY TELLING DONE BY FRANK DAVIS FOR GROWER GROUP ALLIANCE ON 28-06-2022	1	1,500.00	

Ordinary Council Meeting Minutes  
17 August 2022

Date: 01/08/2022  
Time: 9:17:37AM

Shire of Northam

USER: Louise Harris  
PAGE: 31 13

Cheque /EFT No	Date	Name	Invoice Description	Bank Code	INV Amount	Amount
EFT44285	14/07/2022	GOODYEAR & DUNLOP TYRES (AUST) PTY LTD	FN1805 - SUPPLY AND FIT TWO TYRES TO RESPONSE TRUCK AS PER QUOTE U524362892	1		1,349.16
INV 641264730/06/2022		GOODYEAR & DUNLOP TYRES (AUST) PTY LTD	FN1805 - SUPPLY AND FIT TWO TYRES TO RESPONSE TRUCK AS PER QUOTE U524362892	1	1,349.16	
EFT44286	14/07/2022	GRAFTON ELECTRICS	OLD BAKERS HILL FIRE SHED. REPLACE POWE POLE AS PER INSTRUCTION BY WESTER POWER ON RECORD I111105. QUOTE 137.	1		4,114.00
INV 8564	08/04/2022	GRAFTON ELECTRICS	OLD BAKERS HILL FIRE SHED. REPLACE POWE POLE AS PER INSTRUCTION BY WESTER POWER ON RECORD I111105. QUOTE 137.	1	3,696.00	
INV 8783	21/06/2022	GRAFTON ELECTRICS	REPAIR TO BBQ AREA LIGHTS THAT ARE TRIPPING. RCD CHECKED AND SWITCH WILL NOT GO BACK ON.	1	418.00	
EFT44287	14/07/2022	GROVE WESLEY DESIGN ART	NAME BADGES X 4	1		69.20
INV 7083	30/06/2022	GROVE WESLEY DESIGN ART	NAME BADGES X 4	1	69.20	
EFT44288	14/07/2022	HAWK CONCRETE FLOOR COATINGS - RCJ TRUST T/AS	BERNARD PARK TOILETS. GENERATOR HIRE FOR FLOOR GRINDING.	1		825.00
INV INV-63930/06/2022		HAWK CONCRETE FLOOR COATINGS - RCJ TRUST T/AS	BERNARD PARK TOILETS. GENERATOR HIRE FOR FLOOR GRINDING.	1	825.00	
EFT44289	14/07/2022	IT VISION	RENEW SYNERGYSOFT & UNIVERSE ANNUAL LICENSE FEES 01 JULY 2022-30 JUNE 2023	1		100,699.50
INV 37166	01/07/2022	IT VISION	RENEW SYNERGYSOFT & UNIVERSE ANNUAL LICENSE FEES 01 JULY 2022-30 JUNE 2023	1	100,699.50	
EFT44290	14/07/2022	LANDGATE	GROSS RENTAL VALUES REVALUATION 2021/22 COUNTRY REGION	1		92,689.67
INV 375452	02/06/2022	LANDGATE	COUNTRY URBAN UV REVALUATION 2021/2022	1	164.20	
INV 375657	14/06/2022	LANDGATE	GROSS RENTAL VALUES REVALUATION 2021/22 COUNTRY REGION	1	91,649.70	
INV 375870	23/06/2022	LANDGATE	GROSS RENTAL VALUATIONS CHARGEABLE SCHEDULE G2022/7 FROM 14/05/2022 TO 10/06/2022	1	299.37	
INV 119741401/07/2022		LANDGATE	PURCHASE OF 2021 AERIAL PHOTOGRAPHY FOR THE SHIRE OF NORTHAM	1	576.40	

Ordinary Council Meeting Minutes  
17 August 2022



Date: 01/08/2022  
Time: 9:17:37AM

Shire of Northam

USER: Louise Harris  
PAGE: 32 10

Cheque /EFT No	Date	Name	Invoice Description	Bank Code	INV Amount	Amount
EFT44291	14/07/2022	LFA FIRST RESPONSE	FIRST AID POLY WALL SIGN 225 X 225MM / VENTOLIN INHALER 200 METERED DOSES / LE PETITE SPACER	1		176.90
INV IN2509407/07/2022		LFA FIRST RESPONSE	FIRST AID POLY WALL SIGN 225 X 225MM / VENTOLIN INHALER 200 METERED DOSES / LE PETITE SPACER	1	176.90	
EFT44292	14/07/2022	LGIS - LOCAL GOVERNMENT INSURANCE SERVICES	MARINE CARGO ANNUAL INSURANCE PREMIUMS 30/06/2022-30/06/2023	1		9,992.29
INV 062-21230/06/2022		LGIS - LOCAL GOVERNMENT INSURANCE SERVICES	MARINE CARGO ANNUAL INSURANCE PREMIUMS 30/06/2022-30/06/2023	1	1,039.50	
INV 062-21230/06/2022		LGIS - LOCAL GOVERNMENT INSURANCE SERVICES	MARINE CARGO ANNUAL INSURANCE PREMIUMS 30/06/2022-30/06/2023	1	8,952.79	
EFT44293	14/07/2022	LOCAL GOVERNMENT PROFESSIONALS AUSTRALIA WA	LOCAL GOVERNMENT PROFESSIONALS MEMBERSHIP RENEWAL FOR CHADD HUNT	1		531.00
INV 27027 01/07/2022		LOCAL GOVERNMENT PROFESSIONALS AUSTRALIA WA	LOCAL GOVERNMENT PROFESSIONALS MEMBERSHIP RENEWAL FOR CHADD HUNT	1	531.00	
EFT44294	14/07/2022	LUCY'S TEAROOMS	CATERING (LUNCH) STAFF TRAINING - DEALING WITH DIFFICULT CUSTOMERS (MAY 25TH & MAY 26TH	1		425.00
INV 2716	08/06/2022	LUCY'S TEAROOMS	CATERING (LUNCH) STAFF TRAINING - DEALING WITH DIFFICULT CUSTOMERS (MAY 25TH & MAY 26TH	1	425.00	
EFT44295	14/07/2022	MACRI PARTNERS	FINANCIAL MANAGEMENT REVIEW 21/22	1		19,800.00
INV 48121 30/06/2022		MACRI PARTNERS		1	19,800.00	
EFT44296	14/07/2022	MAYDAY EARTHMOVING / RENTAL - CHIVAS ENTERPRISES T-AS	DOZER DRY HIRE - 23/6 - 30/6/22	1		9,548.00
INV 82361	30/06/2022	MAYDAY EARTHMOVING / RENTAL - CHIVAS ENTERPRISES T-AS	DOZER DRY HIRE - 23/6 - 30/6/22	1	9,548.00	
EFT44297	14/07/2022	NIGEL WILLIAM FEEKE	RATES CREDIT REFUND FOR ASSESSMENT A1763	1		750.17
INV A1763	14/07/2022	NIGEL WILLIAM FEEKE	RATES CREDIT REFUND FOR ASSESSMENT A1763		750.17	
EFT44298	14/07/2022	NORTHAM FEED & HIRE	SWAN FOOD & OTHER MISCELLANEOUS ITEMS - JULY 2022	1		127.00
INV 000043030/06/2022		NORTHAM FEED & HIRE	SWAN FOOD & OTHER MISCELLANEOUS ITEMS - JUNE 2022	1	44.00	
INV 000043006/07/2022		NORTHAM FEED & HIRE	SWAN FOOD & OTHER MISCELLANEOUS ITEMS - JULY 2022	1	36.00	

Ordinary Council Meeting Minutes  
17 August 2022



Date: 01/08/2022  
Time: 9:17:37AM

Shire of Northam

USER: Louise Harris  
PAGE: 33 13

Cheque /EFT No	Date	Name	Invoice Description	Bank Code	INV Amount	Amount
INV 000043107/07/2022		NORTHAM FEED & HIRE	SWAN FOOD & OTHER MISCELLANEOUS ITEMS - JULY 2022	1	47.00	
EFT44299	14/07/2022	OFFICEWORKS SUPERSTORES PTY LTD	PACK & ROLL 35KG TROLLEY CART BLACK / AVERY PRINTABLE TABBIES WHITE 48 PACK	1		198.91
INV 601673005/07/2022		OFFICEWORKS SUPERSTORES PTY LTD	PACK & ROLL 35KG TROLLEY CART BLACK / AVERY PRINTABLE TABBIES WHITE 48 PACK	1	198.91	
EFT44300	14/07/2022	PJ & DE ROBINSON	NORTHAM TOY LIBRARY. TREAT MOULD ON WALLS AND CLEAN AFFECTED AREAS.	1		440.00
INV 600004701/07/2022		PJ & DE ROBINSON	NORTHAM TOY LIBRARY. TREAT MOULD ON WALLS AND CLEAN AFFECTED AREAS.	1	440.00	
EFT44301	14/07/2022	REGIONAL CONCRETE & LANDSCAPE	REFUND FOR THE DEVELOPMENT APPLICATION P22068 FEE AS NOT REQUIRED R/N 155521	1		147.00
INV JJ2906229/06/2022		REGIONAL CONCRETE & LANDSCAPE	REFUND FOR THE DEVELOPMENT APPLICATION P22068 FEE AS NOT REQUIRED R/N 155521	1	147.00	
EFT44302	14/07/2022	SAFE T CARD AUSTRALIA PTY LTD	VISTORS CENTRE / KILLARA / LIBRARY / DEVELOPMENT SERVICES - SAFETCARD DEVICE QUARTLEY MONITORING FEES JULY - SEPT 2022	1		924.00
INV INV -30301/07/2022		SAFE T CARD AUSTRALIA PTY LTD	VISTORS CENTRE / KILLARA / LIBRARY / DEVELOPMENT SERVICES - SAFETCARD DEVICE QUARTLEY MONITORING FEES JULY - SEPT 2022	1	924.00	
EFT44303	14/07/2022	SOUTHERN CROSS AUSTEREO PTY LTD	AROUND THE TOWNS INTERVIEWS - SHIRE PRESIDENT - JUNE 2022	1		198.00
INV 713424830/06/2022		SOUTHERN CROSS AUSTEREO PTY LTD	AROUND THE TOWNS INTERVIEWS - SHIRE PRESIDENT - JUNE 2022	1	198.00	
EFT44304	14/07/2022	SPECIALE SMASH REPAIRS	FN2015 - N11131 - INSURANCE EXCESS	1		1,000.00
INV 20745/217/06/2022		SPECIALE SMASH REPAIRS	FN2015 - N11131 - INSURANCE EXCESS	1	1,000.00	
EFT44305	14/07/2022	ST JOHN AMBULANCE AUSTRALIA (FIRST AID COURSE)	ELIJAH MOOREHEAD USI# KHMCRYHQHY FIRST AT REFRESHER AT NORTHAM FACILITY 23/06/2022	1		160.00
INV FAINV023/06/2022		ST JOHN AMBULANCE AUSTRALIA (FIRST AID COURSE)	ELIJAH MOOREHEAD USI# KHMCRYHQHY FIRST AT REFRESHER AT NORTHAM FACILITY 23/06/2022	1	160.00	

Date: 01/08/2022  
Time: 9:17:37AM

Shire of Northam

USER: Louise Harris  
PAGE: 34 10

Cheque /EFT No	Date	Name	Invoice Description	Bank Code	INV Amount	Amount
EFT44306	14/07/2022	T-QUIP	PN2106 - PERUZZO PANTHER PROFESSIONAL 1800 HI-LIFT MOWER PARTS AND REPAIRS ON SITE AS PER QUOTATION 18437 #9. PLUS EXTRA LABOUR COSTS	1		6,248.70
INV 111670	01/07/2022	T-QUIP	PN2106 - PERUZZO PANTHER PROFESSIONAL 1800 HI-LIFT MOWER PARTS AND REPAIRS ON SITE AS PER QUOTATION 18437 #9. PLUS EXTRA LABOUR COSTS	1	6,248.70	
EFT44307	14/07/2022	TOTALLY WORKWEAR MALAGA	50 X CMK-4 COMMUTER FACE MASKS - BLACK	1		575.00
INV 750014520	04/2022	TOTALLY WORKWEAR MALAGA	50 X CMK-4 COMMUTER FACE MASKS - BLACK	1	575.00	
EFT44308	14/07/2022	TRANSWEST WA AUSTRALIAN STONE COMPANY PTY LTD	19MM GRAVEL MRD SPEC	1		7,182.25
INV INV-28930	06/2022	TRANSWEST WA AUSTRALIAN STONE COMPANY PTY LTD	100 TONNE X 19MM GRAVEL MRD SPEC - DELIVERED TO NORTHAM DEPOT	1	1,955.05	
INV INV-28730	06/2022	TRANSWEST WA AUSTRALIAN STONE COMPANY PTY LTD	19MM GRAVEL MRD SPEC	1	1,267.20	
INV INV-28930	06/2022	TRANSWEST WA AUSTRALIAN STONE COMPANY PTY LTD	19MM GRAVEL MRD SPEC	1	3,960.00	
EFT44309	14/07/2022	TYREPOWER LTD	TYRE REPAIR ON CEO VEHICLE	1		31.08
INV 8265.1401	07/2022	TYREPOWER LTD	TYRE REPAIR ON CEO VEHICLE	1	31.08	
EFT44310	14/07/2022	WARRICKS NEWSAGENCY	LIBRARY - MAGAZINE SUBSCRIPTIONS - JUNE 2022	1		315.77
INV 79533	07/04/2022	WARRICKS NEWSAGENCY	LABEL AVERY LASER L6011 H/DUTY SILVER 27UP PKT20 /MANILLA FOLDERS	1	86.70	
INV SN00	0130/06/2022	WARRICKS NEWSAGENCY	LIBRARY - MAGAZINE SUBSCRIPTIONS - JUNE 2022	1	229.07	
EFT44311	14/07/2022	WESTERN AUSTRALIAN TREASURY CORPORATION	GOVERNMENT GUARANTEE FEE FOR THE PERIOD ENDING 30/06/2022	1		20,092.14
INV GFEE J	30/06/2022	WESTERN AUSTRALIAN TREASURY CORPORATION	GOVERNMENT GUARANTEE FEE FOR THE PERIOD ENDING 30/06/2022	1	20,092.14	
EFT44312	14/07/2022	WESTWIDE AUTO ELECTRICS AND AIR CONDITIONING	PN1003 - JUMPSTART/ DIAGNOSE AND BATTERY REPLACEMENT	1		5,048.00
INV INV-13501	05/2022	WESTWIDE AUTO ELECTRICS AND AIR CONDITIONING	INKPEN 3.4U - ATTEND STATION, DIAGNOSE BATTERY FAULT AND REPLACE AS REQUIRED	1	242.50	

Ordinary Council Meeting Minutes  
17 August 2022

Date: 01/08/2022  
Time: 9:17:37AM

Shire of Northam

USER: Louise Harris  
PAGE: 35 13

Cheque /EFT No	Date	Name	Invoice Description	Bank Code	INV Amount	Amount
INV INV-13501/05/2022		WESTWIDE AUTO ELECTRICS AND AIR CONDITIONING	INKPEN 3.4U - ATTEND STATION, DIAGNOSE BATTERY FAULT AND REPLACE AS REQUIRED	1	712.50	
INV INV-13509/05/2022		WESTWIDE AUTO ELECTRICS AND AIR CONDITIONING	NEW BATTERY - WUNDOWIE LT	1	917.50	
INV INV-13613/06/2022		WESTWIDE AUTO ELECTRICS AND AIR CONDITIONING	FN0916 - BATTERY FOR CLARK BOBCAT	1	505.00	
INV INV-13617/06/2022		WESTWIDE AUTO ELECTRICS AND AIR CONDITIONING	NORTHAM CENTRAL 3.4 - DIAGNOSE AND REPAIR FUSE ISSUE WITH CENTRE CONSOLE, TEST ALL SYSTEMS TO ENSURE AMBER BEACONS AND ALL OTHER SYSTEMS ARE FUNCTIONING AS PER MANUFACTURE SPECS	1	247.50	
INV INV-13730/06/2022		WESTWIDE AUTO ELECTRICS AND AIR CONDITIONING	FN1611 - REPLACE REMOTE AERIEL FOR WATER TRUCK PUMP	1	217.50	
INV INV-13730/06/2022		WESTWIDE AUTO ELECTRICS AND AIR CONDITIONING	REPLACE BATTERY ON IRISHTOWN FIRE APPLIANCE	1	762.50	
INV INV-13730/06/2022		WESTWIDE AUTO ELECTRICS AND AIR CONDITIONING	FN1003 - JUMPSTART/ DIAGNOSE AND BATTERY REPLACEMENT	1	1,097.50	
INV INV-13730/06/2022		WESTWIDE AUTO ELECTRICS AND AIR CONDITIONING	FN2012 - N11254 - INVESTIGATE EMERGENCY LIGHT ISSUE	1	345.50	
EFT44313	14/07/2022	WHEATBELT OFFICE & BUSINESS MACHINES (WOBM)	CREATE298 - MONTHLY PHOTOCOPIER READING - 06/06/2022 - 04/07/2022	1		58.90
INV 214207	04/07/2022	WHEATBELT OFFICE & BUSINESS MACHINES (WOBM)	CREATE298 - MONTHLY PHOTOCOPIER READING - 06/06/2022 - 04/07/2022	1	58.90	
EFT44314	14/07/2022	WRIGHT EXPRESS AUSTRALIA PTY LTD (PUMA ENERGY)	FUEL CHARGES FOR JUNE 2022	1		902.51
INV JUNE 2	30/06/2022	WRIGHT EXPRESS AUSTRALIA PTY LTD (PUMA ENERGY)	FUEL CHARGES FOR JUNE 2022	1	902.51	
EFT44315	22/07/2022	AFM PLASTIC PRODUCTS PTY LTD	6MM CLEAR ACRYLIC DISPLAY CASE FOR NORTHAM ART PRIZE ARTWORK	1		258.50
INV 000385505	07/2022	AFM PLASTIC PRODUCTS PTY LTD	6MM CLEAR ACRYLIC DISPLAY CASE FOR NORTHAM ART PRIZE ARTWORK	1	258.50	
EFT44316	22/07/2022	AMPAC DEBT RECOVERY (WA) P/L	DEBT RECOVERY TO 8TH JULY 2022	1		38.50
INV 85952	14/07/2022	AMPAC DEBT RECOVERY (WA) P/L	DEBT RECOVERY TO 8TH JULY 2022	1	38.50	
EFT44317	22/07/2022	APPLIED INDUSTRIAL TECHNOLOGIES T/A NORTHAM BEARINGS	BEARING FOR MOWER	1		5.86

Ordinary Council Meeting Minutes  
17 August 2022

Date: 01/08/2022  
Time: 9:17:37AM

Shire of Northam

USER: Louise Harris  
PAGE: 36 10

Cheque /EFT No	Date	Name	Invoice Description	Bank Code	INV Amount	Amount
INV 697401218/07/2022		APPLIED INDUSTRIAL TECHNOLOGIES T/A NORTHAM BEARINGS	BEARING FOR MOWER	1	5.86	
EFT44318	22/07/2022	ARLENE BYRNES	REFUND PAYMENT MADE IN ERROR - RECEIVED 04/07/2022	1		120.00
INV CY 2107211/07/2022		ARLENE BYRNES	REFUND PAYMENT MADE IN ERROR - RECEIVED 04/07/2022	1	120.00	
EFT44319	22/07/2022	ASTROTOURISM WA PTY LTD	DARK SKY TOURISM - BILYA FESTIVAL - 12 AUGUST 2022	1		3,300.00
INV 1148	08/06/2022	ASTROTOURISM WA PTY LTD	DARK SKY TOURISM - BILYA FESTIVAL - 12 AUGUST 2022	1	3,300.00	
EFT44320	22/07/2022	AUSTRALIAN SAFETY ENGINEERS	SERVICE BA UNITS	1		201.92
INV 015564208/07/2022		AUSTRALIAN SAFETY ENGINEERS	SERVICE BA UNITS	1	201.92	
EFT44321	22/07/2022	AUSTRALIAN SERVICES UNION	PAYROLL DEDUCTIONS	1		129.50
INV DEDUC19/07/2022		AUSTRALIAN SERVICES UNION	PAYROLL DEDUCTIONS		129.50	
EFT44322	22/07/2022	AUTOPRO NORTHAM	GLOBES FOR PN1213	1		5.17
INV 100201330/06/2022		AUTOPRO NORTHAM	GLOBES FOR PN1213	1	5.17	
EFT44323	22/07/2022	AVON WASTE	C.202122-04 MANAGEMENT OF OLD QUARRY ROAD LANDFILL FACILITY - JUNE 2022	1		122,217.55
INV 50096	06/05/2022	AVON WASTE	DOMESTIC / COMMERCIAL RUBBISH COLLECTION - PERIOD ENDING 6TH MAY 2022	1	37,686.58	
INV 50645	17/06/2022	AVON WASTE	DOMESTIC / COMMERCIAL RUBBISH COLLECTION - PERIOD ENDING 17TH JUNE 2022	1	37,410.27	
INV 000506417/06/2022		AVON WASTE	C.202122-04 MANAGEMENT OF OLD QUARRY ROAD LANDFILL FACILITY - JUNE 2022	1	47,120.70	
EFT44324	22/07/2022	BENARA NURSERIES	WESTRINGEA / ANGOZANTHOS / SEDUM	1		1,950.76
INV 378790	18/07/2022	BENARA NURSERIES	WESTRINGEA / ANGOZANTHOS / SEDUM	1	1,950.76	
EFT44325	22/07/2022	BGC (AUSTRALIA) PTY LTD T/A BGC QUARRIES	DELIVER LOAD TO SHIRE OF NORTHAM OLD QUARRY ROAD WASTE MANAGEMENT FACILITY.	1		1,419.01

Ordinary Council Meeting Minutes  
17 August 2022



Date: 01/08/2022  
Time: 9:17:37AM

Shire of Northam

USER: Louise Harris  
PAGE: 37 13

Cheque /EFT No	Date	Name	Invoice Description	Bank Code	INV Amount	Amount
INV IQ3396010/07/2022		BGC (AUSTRALIA) PTY LTD T/A BGC QUARRIES	7MM BLUE METAL	1	586.89	
INV IQ3395910/07/2022		BGC (AUSTRALIA) PTY LTD T/A BGC QUARRIES	DELIVER LOAD TO SHIRE OF NORTHAM OLD QUARRY ROAD WASTE MANAGEMENT FACILITY.	1	832.12	
EFT44326	22/07/2022	BUCCI HOLDINGS PTY LTD T-AS VISIMAX	MICROCHIP READER - DATAMARS, COMPACT MAX, FDXB & A	1		416.48
INV INV-04522/06/2022		BUCCI HOLDINGS PTY LTD T-AS VISIMAX	MICROCHIP READER - DATAMARS, COMPACT MAX, FDXB & A	1	416.48	
EFT44327	22/07/2022	BUNNINGS BUILDING SUPPLIES P/L	16 X THRYPTOMENE PINK LACE	1		580.54
INV 2182/0007/07/2022		BUNNINGS BUILDING SUPPLIES P/L	19MM POLY WITH FITTINGS	1	99.57	
INV 2182/0012/07/2022		BUNNINGS BUILDING SUPPLIES P/L	TRAILER MESH / SIGN / LUBRICANT / HERBICIDE	1	176.83	
INV 2182/0012/07/2022		BUNNINGS BUILDING SUPPLIES P/L	16 X THRYPTOMENE PINK LACE	1	262.24	
INV 2182/0013/07/2022		BUNNINGS BUILDING SUPPLIES P/L	POLY PIPE AND FITTINGS	1	41.90	
EFT44328	22/07/2022	CADD'S FASHIONS	WORKBOOT ALLOWANCE - SONYA LINDNER	1		170.00
INV 22-000013/07/2022		CADD'S FASHIONS	WORKBOOT ALLOWANCE - SONYA LINDNER	1	170.00	
EFT44329	22/07/2022	CADSULT IDS - FISCUS CONTRACTING T/AS	RETICULATION CONCEPT DESIGN BROOME TERRACE AS PER QUOTE	1		1,287.00
INV INV-18430/06/2022		CADSULT IDS - FISCUS CONTRACTING T/AS	RETICULATION CONCEPT DESIGN BROOME TERRACE AS PER QUOTE	1	1,287.00	
EFT44330	22/07/2022	CENTRAL MOBILE MECHANICAL REPAIRS	5X ROLLER SHIFTS	1		7,408.50
INV 000040730/06/2022		CENTRAL MOBILE MECHANICAL REPAIRS	5X ROLLER SHIFTS	1	3,283.50	
INV 000040730/06/2022		CENTRAL MOBILE MECHANICAL REPAIRS	PICK UP 2X ROLLERS FROM FRENCHES ROAD AND DROP OFF AT HABGOOD ROOD	1	709.50	
INV 000040713/07/2022		CENTRAL MOBILE MECHANICAL REPAIRS	PICK UP STEEL DRUM ROLLER FROM BELMUGGIN RD AND DROP OFF AT HENRY ST OVAL 07/07/2022 / PICK UP MULTI ROLLER FROM BELMUGGIN RD AND DROP OFF AT HENRY ST OVAL 07/07/2022 / PICK UP MULTI ROLLER FROM CNR HITCHCOCK & CLYDESDALE RDS AND DROP OFF AT CNR SCOTT AND SOUTHERN BROOK RDS 11/07/2022	1	2,128.50	



Ordinary Council Meeting Minutes  
17 August 2022



Date: 01/08/2022  
Time: 9:17:37AM

Shire of Northam

USER: Louise Harris  
PAGE: 38 10

Cheque /EFT No	Date	Name	Invoice Description	Bank Code	INV Amount	Amount
INV 000040814/07/2022		CENTRAL MOBILE MECHANICAL REPAIRS	PICK UP STEEL DRUM ROLLER FROM HENRY ST AND DROP OFF AT ENRIGHT PARK	1	577.50	
INV 000040814/07/2022		CENTRAL MOBILE MECHANICAL REPAIRS	PICK UP STEEL DRUM ROLLER FROM ENRIGHT PARK AND DROP OFF AT EADINE RD (JUST BEFORE SMITH RD)	1	709.50	
EFT44331	22/07/2022	CHADSON ENGINEERING	3 X SERVICING PALINTEST INCLUDING DELIVERY	1		1,244.10
INV A00984	07/07/2022	CHADSON ENGINEERING	3 X SERVICING PALINTEST INCLUDING DELIVERY	1	951.50	
INV A00984	07/07/2022	CHADSON ENGINEERING	PALINTEST KIT, SERIAL NO. PT709P0814370 - SERVICE AND CALIBRATION (FREIGHT INC)	1	292.60	
EFT44332	22/07/2022	CHILD SUPPORT AGENCY	PAYROLL DEDUCTIONS	1		429.54
INV DEDUC19/07/2022		CHILD SUPPORT AGENCY	PAYROLL DEDUCTIONS		429.54	
EFT44333	22/07/2022	CLEANAWAY DANIEL S SERVICES PTY LTD	BERNARD PARK PUBLIC TOILETS X 3 SHARPS DISPOSAL SERVICE 27/06/2022	1		618.82
INV 209180830/06/2022		CLEANAWAY DANIEL S SERVICES PTY LTD	BAKERS HILL HOOPER PARK PUBLIC TOILETS X 2 SHARPS DISPOSAL SERVICE 09/06/2022 & 27/06/2022	1	103.14	
INV 209180930/06/2022		CLEANAWAY DANIELS SERVICES PTY LTD	BERNARD PARK PUBLIC TOILETS X 3 SHARPS DISPOSAL SERVICE 27/06/2022	1	206.27	
INV 209181030/06/2022		CLEANAWAY DANIEL S SERVICES PTY LTD	APEX PARK PUBLIC TOILETS X 4 SHARPS DISPOSAL SERVICE 9/6/22 & 27/6/22	1	206.27	
INV 209181130/06/2022		CLEANAWAY DANIEL S SERVICES PTY LTD	WUNDOWIE PUBLIC TOILETS X 2 SHARPS DISPOSAL SERVICE 09/06/2022	1	103.14	
EFT44334	22/07/2022	COLES SUPERMARKETS PTY LTD	COLES PURCHASES - JUNE 2022 - KILLARA / REC CENTRE / DEPOT / LIBRARY / COMMUNITY DEVELOPMENT / ADMIN / COUNCILLOR MEETINGS / DEVELOPMENT SERVICES	1		2,915.42
INV 180	30/06/2022	COLES SUPERMARKETS PTY LTD	COLES PURCHASES - JUNE 2022 - KILLARA / REC CENTRE / DEPOT / LIBRARY / COMMUNITY DEVELOPMENT / ADMIN / COUNCILLOR MEETINGS / DEVELOPMENT SERVICES	1	2,915.42	
EFT44335	22/07/2022	COMBINED TYRES PTY LTD	FN1806 - 2 x COASTER BUS TYRES. 17701851 - 215/70R17.5 YOKOHAMA, INCLUDING DISPOSAL	1		1,094.50
INV INV -24513/07/2022		COMBINED TYRES PTY LTD	FN1806 - 2 x COASTER BUS TYRES. 17701851 - 215/70R17.5 YOKOHAMA, INCLUDING DISPOSAL	1	1,094.50	

Date: 01/08/2022  
Time: 9:17:37AM

Shire of Northam

USER: Louise Harris  
PAGE: 39 13

Cheque /EFT No	Date	Name	Invoice Description	Bank Code	INV Amount	Amount
EFT44336	22/07/2022	COUNTRY COPIERS NORTHAM	DYMO LABEL WRITERS	1		718.55
INV 45034	31/05/2022	COUNTRY COPIERS NORTHAM	DYMO LABEL WRITERS	1	336.65	
INV 45034	31/05/2022	COUNTRY COPIERS NORTHAM	STICKERS FOR NATIVE PLANT GIVEAWAY	1	74.75	
INV 45034	31/05/2022	COUNTRY COPIERS NORTHAM	INK CARTRIDGES COLOUR (C,M,Y) VALUE PACK @ \$109.45 EACH X 2 = \$218.90	1	218.90	
INV 45034	31/05/2022	COUNTRY COPIERS NORTHAM	USB	1	15.80	
INV 45034	31/05/2022	COUNTRY COPIERS NORTHAM	POSTER CARDS	1	10.65	
INV 45034	31/05/2022	COUNTRY COPIERS NORTHAM	89X62 AVERY LABELS	1	43.20	
INV 45034	31/05/2022	COUNTRY COPIERS NORTHAM	POSTER CARDS	1	18.60	
EFT44337	22/07/2022	COUNTRYWIDE GROUP	T435 CHAINSAW REPAIRS	1		978.49
INV ACC00104/07/2022		COUNTRYWIDE GROUP	ACCELERATOR CABLE FOR A ROTARY HOE	1	33.63	
INV ACC00113/07/2022		COUNTRYWIDE GROUP	T435 CHAINSAW REPAIRS	1	30.00	
INV ACC00113/07/2022		COUNTRYWIDE GROUP	T435 CHAINSAW REPAIRS	1	77.99	
INV ACC00113/07/2022		COUNTRYWIDE GROUP	T435 CHAINSAW REPAIRS	1	209.99	
INV ACC00113/07/2022		COUNTRYWIDE GROUP	T435 CHAINSAW REPAIRS	1	117.80	
INV ACC00113/07/2022		COUNTRYWIDE GROUP	T435 CHAINSAW REPAIRS	1	359.99	
INV ACC00114/07/2022		COUNTRYWIDE GROUP	PN1903 -HUSQVANA MOWER REPAIRS	1	149.09	
EFT44338	22/07/2022	DCM CARPENTRY & MAINTENANCE	VISITORS CENTRE. REPLACE DAMAGED DECKING BOARD NEAR CAFE.	1		328.90
INV 1400	21/06/2022	DCM CARPENTRY & MAINTENANCE	VISITORS CENTRE. REPLACE DAMAGED DECKING BOARD NEAR CAFE.	1	328.90	
EFT44339	22/07/2022	DEPARTMENT OF WATER & ENVIRONMENT REGULATION	ANNUAL DWER LICENCE FEE FOR 2022 2023 - OLD QUARRY ROAD WASTE FACILITY - LICENCE L6977/1997/10.	1		6,952.00
INV W-L697	12/07/2022	DEPARTMENT OF WATER & ENVIRONMENT REGULATION	ANNUAL DWER LICENCE FEE FOR 2022 2023 - OLD QUARRY ROAD WASTE FACILITY - LICENCE L6977/1997/10.	1	6,952.00	

Ordinary Council Meeting Minutes  
17 August 2022

Date: 01/08/2022  
Time: 9:17:37AM

Shire of Northam

USER: Louise Harris  
PAGE: 40 10

Cheque /EFT No	Date	Name	Invoice Description	Bank Code	INV Amount	Amount
EFT44340	22/07/2022	DIANA MARIE SPENCER	RATES CREDIT REFUND FOR ASSESSMENT A10935 70 FORREST STREET NORTHAM WA 6401	1		200.00
INV A10935	22/07/2022	DIANA MARIE SPENCER	RATES CREDIT REFUND FOR ASSESSMENT A10935 70 FORREST STREET NORTHAM WA 6401		200.00	
EFT44341	22/07/2022	DMC CLEANING	CLEANING OF SHIRE OF NORTHAM FACILITIES - C202021-05 - 1/6/2022 - 30/6/2022	1		8,694.41
INV SON20930	06/2022	DMC CLEANING	CLEANING OF SHIRE OF NORTHAM FACILITIES - C202021-05 - 1/6/2022 - 30/6/2022	1	8,694.41	
EFT44342	22/07/2022	DOREEN STACK	RETURN BOND FOR PAMENT ON BOOKING 5284	1		100.00
INV 13274	13/07/2022	DOREEN STACK	RETURN BOND FOR PAMENT ON BOOKING 5284	1	100.00	
EFT44343	22/07/2022	EASIFLEET	PAYROLL DEDUCTIONS	1		1,853.35
INV DEDUC	19/07/2022	EASIFLEET	PAYROLL DEDUCTIONS		1,054.26	
INV DEDUC	19/07/2022	EASIFLEET	PAYROLL DEDUCTIONS		799.09	
EFT44344	22/07/2022	ECOMIST SWAN	3 X SANITARY (ECOMIST) BINS YEARLY SERVICE / 5 X FRAGRANCE YEARLY SERVICE / 1 X INSECT CONTROL YEARLY SERVICE	1		1,663.31
INV 00061	1808/07/2022	ECOMIST SWAN	3 X SANITARY (ECOMIST) BINS YEARLY SERVICE / 5 X FRAGRANCE YEARLY SERVICE / 1 X INSECT CONTROL YEARLY SERVICE	1	1,663.31	
EFT44345	22/07/2022	GHD PTY LTD	C.202122-10 SHIRE OF NORTHAM REUSE WATER SCHEME UPGRADE	1		3,680.60
INV 112-01207	07/2022	GHD PTY LTD	C.202122-10 SHIRE OF NORTHAM REUSE WATER SCHEME UPGRADE	1	3,680.60	
EFT44346	22/07/2022	GOODYEAR & DUNLOP TYRES (AUST) PTY LTD	FN1602 - MITSU UTE, SUPPLY AND FIT 4 TYRES INCLUDING DISPOSAL. AS PER QUOTE U524107540	1		1,375.49
INV 641265808	07/2022	GOODYEAR & DUNLOP TYRES (AUST) PTY LTD	FN1502 - REPLACE ROLLER TYRE ON SITE, HITCHCOCK RD	1	321.55	
INV 641266614	07/2022	GOODYEAR & DUNLOP TYRES (AUST) PTY LTD	FN1705 - MOWER PUNCTURE REPAIR	1	53.72	
INV 641266514	07/2022	GOODYEAR & DUNLOP TYRES (AUST) PTY LTD	FN1602 - MITSU UTE, SUPPLY AND FIT 4 TYRES INCLUDING DISPOSAL. AS PER QUOTE U524107540	1	758.54	

Ordinary Council Meeting Minutes  
17 August 2022

Date: 01/08/2022  
Time: 9:17:37AM

Shire of Northam

USER: Louise Harris  
PAGE: 41 13

Cheque /EFT No	Date	Name	Invoice Description	Bank Code	INV Amount	Amount
INV 641267018/07/2022		GOODYEAR & DUNLOP TYRES (AUST) PTY LTD	FN1802- REGO 1TTO41. REPLACE WOODCHIPPER TYRE	1	241.68	
EFT44347	22/07/2022	GRAFTON ELECTRICS	AERODROME. REPAIR/REPLACE RUNWAY LIGHT 44 THAT HAS BEEN DAMAGED.	1		110.00
INV 8768	23/06/2022	GRAFTON ELECTRICS	AERODROME. REPAIR/REPLACE RUNWAY LIGHT 44 THAT HAS BEEN DAMAGED.	1	110.00	
EFT44348	22/07/2022	HER MAJESTY BALLROOM	REIMBURSE BOND FO BOOKING 5281	1		100.00
INV 13278	19/07/2022	HER MAJESTY BALLROOM	REIMBURSE BOND FO BOOKING 5281	1	100.00	
EFT44349	22/07/2022	IRRIGATION AUSTRALIA LTD	MEMBERSHIP FEE FOR PERIOD 01/07/2022 TO 30/06/2023	1		780.00
INV 307516212/07/2022		IRRIGATION AUSTRALIA LTD	MEMBERSHIP FEE FOR PERIOD 01/07/2022 TO 30/06/2023	1	780.00	
EFT44350	22/07/2022	IW PROJECTS ATF THE CARMEL TRUST	NORTHAM OLD LANDFILL CAPPING INVESTIGATION AND REPORTING AS PER QUOTE PROVIDED.	1		11,440.00
INV 1451	30/06/2022	IW PROJECTS ATF THE CARMEL TRUST	NORTHAM OLD LANDFILL CAPPING INVESTIGATION AND REPORTING AS PER QUOTE PROVIDED.	1	11,440.00	
EFT44351	22/07/2022	IXOM OPERATIONS PTY LTD	CLORINE MONTHLY SERVICE FEE FOR JUNE 2022	1		505.89
INV 654374730/06/2022		IXOM OPERATIONS PTY LTD	CLORINE MONTHLY SERVICE FEE FOR JUNE 2022	1	337.26	
INV 654374730/06/2022		IXOM OPERATIONS PTY LTD	CLORINE MONTHLY SERVICE FEE FOR NORTHAM AQUATIC FACILITY - JUNE 2022	1	168.63	
EFT44352	22/07/2022	J & A BUILDING PTY LTD	PROGRESS CLAIM 7 - COMPLETION OF CONCRETE WORKS - FOOTING EXCAVATION / STEEL REINFORCING / FOTTING AND CONCRETE POURS	1		42,177.08
INV 000032925/05/2022		J & A BUILDING PTY LTD	PROGRESS CLAIM 7 - COMPLETION OF CONCRETE WORKS - FOOTING EXCAVATION / STEEL REINFORCING / FOTTING AND CONCRETE POURS	1	41,157.08	
INV T1610	22/07/2022	J & A BUILDING PTY LTD	REFUND OF INFRASTRUCTURE BOND - NO DAMAGE	1	1,020.00	
EFT44353	22/07/2022	JULIE WYNNE	FACEPAINTING DONE BY JASMINE WYNNE FOR NAIDOC CELEBRATIONS @ BILYA KOORT BOODJA 07-07-2022	1		200.00

Ordinary Council Meeting Minutes  
17 August 2022



Date: 01/08/2022  
Time: 9:17:37AM

Shire of Northam

USER: Louise Harris  
PAGE: 42 10

Cheque /EFT No	Date	Name	Invoice Description	Bank Code	INV Amount	Amount
INV 13	07/07/2022	JULIE WYNNE	FACEPAINTING DONE BY JASMINE WYNNE FOR NAIDOC CELEBRATIONS @ BILYA KOORT BOODJA 07-07-2022	1	200.00	
EFT44354	22/07/2022	KLEENWEST DISTRIBUTORS	CHEMICALS, MEDIUM GLOVES, PLASTIC CONTAINERS AND TOILET PAPER FOR KILLARA	1		398.59
INV 000704706/07/2022		KLEENWEST DISTRIBUTORS	CHEMICALS, MEDIUM GLOVES, PLASTIC CONTAINERS AND TOILET PAPER FOR KILLARA	1	398.59	
EFT44355	22/07/2022	LOCAL GOVERNMENT PROFESSIONALS AUSTRALIA WA	LOCAL GOVERNMENT PROFESSIONALS MEMBERSHIP RENEWAL FOR JASON WHITAKER	1		531.00
INV 27015 01/07/2022		LOCAL GOVERNMENT PROFESSIONALS AUSTRALIA WA	LOCAL GOVERNMENT PROFESSIONALS MEMBERSHIP RENEWAL FOR JASON WHITAKER	1	531.00	
EFT44356	22/07/2022	LUCY'S TEAROOMS	CATERING - ORDINARY COUNCIL MEETING - 16/02/2022 / CATERING - AVON MIDLAND ZONE MEETING - 18/02/2022	1		1,626.50
INV 2675	02/03/2022	LUCY'S TEAROOMS	CATERING - ORDINARY COUNCIL MEETING - 16/02/2022 / CATERING - AVON MIDLAND ZONE MEETING - 18/02/2022	1	945.00	
INV 2679	02/03/2022	LUCY'S TEAROOMS	CATERING - REGIONAL ROAD GROUP MEETING 28/02/2022	1	212.50	
INV 2658	02/03/2022	LUCY'S TEAROOMS	CATERING - ORDINARY COUNCIL MEETING 19/01/2022	1	334.00	
INV 2689	02/05/2022	LUCY'S TEAROOMS	CATERING FOR CITIZENSHIP CEREMONY ON 25 MARCH 2022	1	135.00	
EFT44357	22/07/2022	MAD DOG PROMOTIONS	TITAN TORCH KEY RING / HOUSE PVC KEYTAG K15 / CAR/VAN PVC KEYTAG K13	1		3,509.00
INV INV -40206/07/2022		MAD DOG PROMOTIONS	TITAN TORCH KEY RING / HOUSE PVC KEYTAG K15 / CAR/VAN PVC KEYTAG K13	1	3,509.00	
EFT44358	22/07/2022	MENTAL MEDIA PTY LTD	GUIDE ID (PODCATCHER) SUBSCRIPTION SERVICE JULY - SEPTEMBER 2022	1		1,938.42
INV 1321	05/07/2022	MENTAL MEDIA PTY LTD	GUIDE ID (PODCATCHER) SUBSCRIPTION SERVICE JULY - SEPTEMBER 2022	1	1,938.42	
EFT44359	22/07/2022	MIRANDA CHORLTON	RETURN OF BOND FOR HIRE OF WUNDOWIE HALL #5178	1		100.00
INV 5178	14/07/2022	MIRANDA CHORLTON	RETURN OF BOND FOR HIRE OF WUNDOWIE HALL #5178	1	100.00	
EFT44360	22/07/2022	NORTHAM BETTA HOME LIVING	3X HELLER HEATERS	1		209.85

Ordinary Council Meeting Minutes  
17 August 2022

Date: 01/08/2022  
Time: 9:17:37AM

Shire of Northam

USER: Louise Harris  
PAGE: 43 13

Cheque /EFT No	Date	Name	Invoice Description	Bank Code	INV Amount	Amount
INV 200100412/07/2022		NORTHAM BETTA HOME LIVING	3X HELLER HEATERS	1	209.85	
EFT44361	22/07/2022	NORTHAM FEED & HIRE	SWAN FOOD & OTHER MISCELLANEOUS ITEMS - JULY 2022	1		24.50
INV 000043212/07/2022		NORTHAM FEED & HIRE	SWAN FOOD & OTHER MISCELLANEOUS ITEMS - JULY 2022	1	24.50	
EFT44362	22/07/2022	PERTH ENERGY PTY LTD	ELECTRICITY CHARGES FOR ACCOUNT 601148 - 182 FITZGERALD ST, NORTHAM (POP UP SHOP) - STATEMENT NO: 2286500	1		189.90
INV 228650015/07/2022		PERTH ENERGY PTY LTD	ELECTRICITY CHARGES FOR ACCOUNT 601148 - 182 FITZGERALD ST, NORTHAM (POP UP SHOP) - STATEMENT NO: 2286500	1	189.90	
EFT44363	22/07/2022	POOL AND PUMP SERVICE AND REPAIRS	CHLORINE GAS TREATMENT SYSTEM - - INSPECTION, - REMOVE FAULTY COMPONENTS, - PROVIDE TECHNICAL SERVICE REQUIREMENTS FOR (RFQ), - PROVIDE QUOTATION ON REPAIR OR REPAcement OF CHLORINE GAS COMPONENT FAULTS	1		1,069.20
INV PPS006	12/07/2022	POOL AND PUMP SERVICE AND REPAIRS	CHLORINE GAS TREATMENT SYSTEM - - INSPECTION, - REMOVE FAULTY COMPONENTS, - PROVIDE TECHNICAL SERVICE REQUIREMENTS FOR (RFQ), - PROVIDE QUOTATION ON REPAIR OR REPAcement OF CHLORINE GAS COMPONENT FAULTS	1	1,069.20	
EFT44364	22/07/2022	SAFETY BARRIERS WA PTY LTD	C.202122-12 MITCHELL AVE GUARD RAIL INSALLATION AND ASSOC WORKS.	1		87,318.00
INV 000058930/06/2022		SAFETY BARRIERS WA PTY LTD	C.202122-12 MITCHELL AVE GUARD RAIL INSALLATION AND ASSOC WORKS.	1	87,318.00	
EFT44365	22/07/2022	SIGMA CHEMICALS	ELECTROLYTE GEL / FREIGHT	1		182.60
INV 157960/25/05/2022		SIGMA CHEMICALS	ELECTROLYTE GEL / FREIGHT	1	155.10	
INV 158262/31/05/2022		SIGMA CHEMICALS	DELIVERY FROM SIGMA	1	27.50	

Date: 01/08/2022  
Time: 9:17:37AM

Shire of Northam

USER: Louise Harris  
PAGE: 44 10

Cheque /EFT No	Date	Name	Invoice Description	Bank Code	INV Amount	Amount
EFT44366	22/07/2022	SIMON PAYNE T/A ROOF ACCESS WA	ROOF ACECESS AUDIT AND REPORT - 2022 - ADMIN / AQUATIC / BAKER HILL REC/ BKB / OLD PO / NORTH REC CENTRE / OLD TOWN HALL	1		2,640.00
INV 220516	07/07/2022	SIMON PAYNE T/A ROOF ACCESS WA	ROOF ACECESS AUDIT AND REPORT - 2022 - ADMIN / AQUATIC / BAKER HILL REC/ BKB / OLD PO / NORTH REC CENTRE / OLD TOWN HALL	1	2,640.00	
EFT44367	22/07/2022	SNAP PRINTING NORTHBRIDGE T/AS ML SN PTY LTD	1000x A5 FRIDGE MAGNETS	1		2,379.99
INV F040-3329/06/2022		SNAP PRINTING NORTHBRIDGE T/AS ML SN PTY LTD	1000x A5 FRIDGE MAGNETS	1	1,638.11	
INV F040-3329/06/2022		SNAP PRINTING NORTHBRIDGE T/AS ML SN PTY LTD	500x A6 FRIDGE MAGNETS (250 X TWO KINDS)	1	741.88	
EFT44368	22/07/2022	SPECIALISED TREE SERVICE	150 YILGARN AVE NORTHAM. ALONG FENCE LINE OF NORTHAM CARAVAN PARK. SAFELY DISMANTLE TO GROUND LEVEL 4 LARGE AND 1 SMALL DEAD TREE. ALL MATERIAL REMOVED FROM SITE. SAFELY COMPLETE MAJOR DEAD WOOD REMOVAL FROM TWIN TRUNK TREE, ALL MATERIAL REMOVED FROM SITE. AS PER QUOTE 1038	1		3,135.00
INV 3892	14/07/2022	SPECIALISED TREE SERVICE	150 YILGARN AVE NORTHAM. ALONG FENCE LINE OF NORTHAM CARAVAN PARK. SAFELY DISMANTLE TO GROUND LEVEL 4 LARGE AND 1 SMALL DEAD TREE. ALL MATERIAL REMOVED FROM SITE. SAFELY COMPLETE MAJOR DEAD WOOD REMOVAL FROM TWIN TRUNK TREE, ALL MATERIAL REMOVED FROM SITE. AS PER QUOTE 1038	1	3,135.00	
EFT44369	22/07/2022	SPORTSPOWER NORTHAM H & H JOUBERT	NETBALL BIBS	1		130.00
INV 22-000011/07/2022		SPORTSPOWER NORTHAM H & H JOUBERT	NETBALL BIBS	1	130.00	

Ordinary Council Meeting Minutes  
17 August 2022



Date: 01/08/2022  
Time: 9:17:37AM

Shire of Northam

USER: Louise Harris  
PAGE: 45 13

Cheque /EFT No	Date	Name	Invoice Description	Bank Code	INV Amount	Amount
EFT44370	22/07/2022	ST JOHN AMBULANCE AUSTRALIA (FIRST AID COURSE)	FIRST AID - 2 DAY COURSE - 28/29 JUNE 2022 TIM EDMONDS, RUSSELL FITZGERALD, ROB SMITH, COLIN MCPHERSON, JOSEPH WILLIAMS, SUSAN CLAYTON, ERROL GARLETT, PHILLIP WHITE, CHARLES CARR	1		1,944.00
INV FAINV029/06/2022		ST JOHN AMBULANCE AUSTRALIA (FIRST AID COURSE)	FIRST AID - 2 DAY COURSE - 28/29 JUNE 2022 TIM EDMONDS, RUSSELL FITZGERALD, ROB SMITH, COLIN MCPHERSON, JOSEPH WILLIAMS, SUSAN CLAYTON, ERROL GARLETT, PHILLIP WHITE, CHARLES CARR	1	1,944.00	
EFT44371	22/07/2022	STALLION BUILDING CO PTY LTD T/A STALLION HOMES	FINAL RELEASE OF DEFECTS LIABILITY RETENTION FOR C.202021-03 NORTHAM YOUTH PRECINCT PUBLIC TOILET AMENITY	1		4,380.01
INV T1578	22/07/2022	STALLION BUILDING CO PTY LTD T/A STALLION HOMES	FINAL RELEASE OF DEFECTS LIABILITY RETENTION FOR C.202021-03 NORTHAM YOUTH PRECINCT PUBLIC TOILET AMENITY	1	4,380.01	
EFT44372	22/07/2022	STATE LIBRARY OF WESTERN AUSTRALIA	BETTER BEGINNINGS INVOICE 2022 -23	1		638.00
INV RI0327513/07/2022		STATE LIBRARY OF WESTERN AUSTRALIA	BETTER BEGINNINGS INVOICE 2022 -23	1	638.00	
EFT44373	22/07/2022	STEPHEN RALPH CRANE	REBATE FOR CROSSOVER CONSTRUCTION AT 8 ORCHID TERRACE	1		1,000.00
INV SP 010701/07/2022		STEPHEN RALPH CRANE	REBATE FOR CROSSOVER CONSTRUCTION AT 8 ORCHID TERRACE	1	1,000.00	
EFT44374	22/07/2022	SYNERGY	335820940 CREATE 298 - 18/05/2022 to 14/06/2022	1		1,872.27
INV 335820915/06/2022		SYNERGY	335820940 CREATE 298 - 18/05/2022 to 14/06/2022		702.45	
INV 444997329/06/2022		SYNERGY	444997300 WUNDOWIE LIBRARY & GARDENS - 29/04/2022 to 28/06/2022		453.06	
INV 353464104/07/2022		SYNERGY	035346410 HOOOPER PARK - 04/05/2022 to 30/06/2022		170.50	
INV 361333412/07/2022		SYNERGY	361333420 AVON MALL - 12/05/2022 to 11/07/2022		546.26	



Ordinary Council Meeting Minutes  
17 August 2022

Date: 01/08/2022  
Time: 9:17:37AM

Shire of Northam

USER: Louise Harris  
PAGE: 46 10

Cheque /EFT No	Date	Name	Invoice Description	Bank Code	INV Amount	Amount
EFT44375	22/07/2022	TALIS CONSULTANTS PTY LTD	DAMAGE PICKUP OF ENTIRE NETWORK AND PROJECT MANAGEMENT AS PER CONTRACT C.202021-24. 1VEHICLE, 2PERSONS INCL MEALS AND ACCOMODATION. STORM EVENT 2-4MARCH2021 - AGRN962 - CONSULTANCE SERVICE FOR PERIOD ENDING 30 JUNE 2022	1		5,486.25
INV 25791	30/06/2022	TALIS CONSULTANTS PTY LTD	DAMAGE PICKUP OF ENTIRE NETWORK AND PROJECT MANAGEMENT AS PER CONTRACT C.202021-24. 1VEHICLE, 2PERSONS INCL MEALS AND ACCOMODATION. STORM EVENT 2-4MARCH2021 - AGRN962 - CONSULTANCE SERVICE FOR PERIOD ENDING 30 JUNE 2022	1	5,486.25	
EFT44376	22/07/2022	TAMIKA VAN BEEK	FOOD AND PARKING FOR LICENSING TRAINING / RECOUP FROM DEPT OF TRAINING	1		102.83
INV CY 150715/07/2022	07/2022	TAMIKA VAN BEEK	FOOD AND PARKING FOR LICENSING TRAINING / RECOUP FROM DEPT OF TRAINING	1	102.83	
EFT44377	22/07/2022	TELSTRA CORPORATION	TELSTRA CHARGES - JUNE 2022 - ADMIN INTERNET	1		7,631.42
INV 272600904/07/2022	07/2022	TELSTRA CORPORATION	TELSTRA CHARGES - JUNE 2022 - HARVEST BAN	1	1.25	
INV 272600810/07/2022	07/2022	TELSTRA CORPORATION	TELSTRA CHARGES - JUNE 2022 - COUNCILLOR IPADS / ADMIN / FINANCE / CESM / BUSHFIRES / RANGER SERVICES / CCTV / HEATH / KILLARA / LANDFILL / PLANNING / WUNDOWIE POOL / NORTHAM LIBRARY / BKB / ENGINEERING / BUILDING / VISITORS CENTRE / REC CENTRE / SES	1	2,637.68	
INV 225839814/07/2022	07/2022	TELSTRA CORPORATION	TELSTRA CHARGES - JUNE 2022 - ADMIN INTERNET	1	4,071.10	
INV 272600916/07/2022	07/2022	TELSTRA CORPORATION	TELSTRA CHARGES - JUNE 2022 - ENGINEERING	1	4.41	
INV 902607517/07/2022	07/2022	TELSTRA CORPORATION	TELSTRA CHARGES - JUNE 2022 - ADMIN / FINANCE / INTERNET / HARVEST BAN / KILLARA INTERNET / LANDFILL / WUNDOWIE POOL / WUNDOWIE LIBRARY / CREATE 298 / ENGINEERING / LANDFILL INTERNET / REC CENTRE / CESM / BUSHFIRES	1	916.98	
EFT44378	22/07/2022	TENNANT AUSTRALIA	3 X YEARLY SERVICE OF FLOOR SCRUBBERS. T1 AND T7 MACHINES - JUNE 2022	1		608.30

Ordinary Council Meeting Minutes  
17 August 2022

Date: 01/08/2022  
Time: 9:17:37AM

Shire of Northam

USER: Louise Harris  
PAGE: 47 13

Cheque /EFT No	Date	Name	Invoice Description	Bank Code	INV Amount	Amount
INV 918838901	07/2022	TENNANT AUSTRALIA	3 X YEARLY SERVICE OF FLOOR SCRUBBERS. T1 AND T7 MACHINES - JUNE 2022	1	608.30	
EFT44379	22/07/2022	TOLL - IPEC PTY LTD T/AS	TOLL FREIGHT CHARGES - JULY 2022 - REC CENTRE / DEPOT	1		69.53
INV 0551-S303	07/2022	TOLL - IPEC PTY LTD T/AS	FREIGHT CHARGES - JULY 2022 - HEALTH	1	13.05	
INV 0552-S310	07/2022	TOLL - IPEC PTY LTD T/AS	TOLL FREIGHT CHARGES - JULY 2022 - REC CENTRE / HEALTH	1	28.07	
INV 0553-S317	07/2022	TOLL - IPEC PTY LTD T/AS	TOLL FREIGHT CHARGES - JULY 2022 - REC CENTRE / DEPOT	1	28.41	
EFT44380	22/07/2022	TOTAL TRAINING GROUP PTY LTD	AHCPGD305 - OPERATION INSPECTION - LEVEL 2 ONLINE TRAINING FOR JASON LINDNER USI 2MF55K2QCH AND TIM EDMONDS USI NL T9Y8AMXC	1		3,100.00
INV INV-C7706	07/2022	TOTAL TRAINING GROUP PTY LTD	AHCPGD305 - OPERATION INSPECTION - LEVEL 2 ONLINE TRAINING FOR JASON LINDNER USI 2MF55K2QCH AND TIM EDMONDS USI NL T9Y8AMXC	1	3,100.00	
EFT44381	22/07/2022	TPG TELECOM	TPG CHARGES - JUNE 2022 - ADMIN / FINANCE / BKB / CESM / CREATE 298 / ENGINEERING / HEALTH / BUILDING / KILLARA / LIBRARY NORTHAM / LIBRARY WUNDOWIE / PLANNING / RANGER SERVICES / REC CENTRE / VISITORS CENTRE / IT	1		8,502.54
INV 179306001	07/2022	TPG TELECOM	TPG CHARGES - JUNE 2022 - CREATE 298 / SES / BFB	1	705.52	
INV 179332401	07/2022	TPG TELECOM	TPG CHARGES - JUNE 2022 - ADMIN / FINANCE / BKB / CESM / CREATE 298 / ENGINEERING / HEALTH / BUILDING / KILLARA / LIBRARY NORTHAM / LIBRARY WUNDOWIE / PLANNING / RANGER SERVICES / REC CENTRE / VISITORS CENTRE / IT	1	7,797.02	
EFT44382	22/07/2022	VINCELEC	VISITORS CENTRE. REPLACE BROKEN FLOODLIGHT AT VIS CENTRE WITH CHERRY PICKER.	1		1,416.40
INV IV1361	12/07/2022	VINCELEC	VISITORS CENTRE. REPLACE BROKEN FLOODLIGHT AT VIS CENTRE WITH CHERRY PICKER.	1	1,416.40	
EFT44383	22/07/2022	WA CONTRACT RANGER SERVICES	C.201920-09 - MANAGMENT OF SHIRE OF NORTHAM DOG IMPOUND FACILITY 27/6/22 - 10/7/22	1		1,705.00
INV 000040614	07/2022	WA CONTRACT RANGER SERVICES	CAT MANAGEMENT EXPENSES FOR JUNE 2022	1	200.00	

Ordinary Council Meeting Minutes  
17 August 2022

Date: 01/08/2022  
Time: 9:17:37AM

Shire of Northam

USER: Louise Harris  
PAGE: 48 10

Cheque /EFT No	Date	Name	Invoice Description	Bank Code	INV Amount	Amount
INV 000040614/07/2022		WA CONTRACT RANGER SERVICES	CAT MANAGEMENT EXPNCES FOR JUNE 2022	1	185.00	
INV 000040614/07/2022		WA CONTRACT RANGER SERVICES	C.201920-09 - MANAGMENT OF SHIRE OF NORTHAM DOG IMPOUND FACILITY 27/6/22 - 10/7/22	1	1,320.00	
EFT44384	22/07/2022	WARRICKS NEWSAGENCY	STATIONERY SUPPLIES - ADMIN OFFICE	1		246.37
INV SN00 0130/06/2022		WARRICKS NEWSAGENCY	NEWSPAPERS FOR KILLARA - JUNE 2022	1	35.70	
INV 67108 11/07/2022		WARRICKS NEWSAGENCY	STATIONERY SUPPLIES - ADMIN OFFICE	1	210.67	
EFT44385	22/07/2022	WESTLINE PLUMBING & DRAINAGE PTY LTD	NORTHAM DEPOT REDEVELOPMENT. INSTALL SEWER EXTENSION AS PER WATERCORP SPECIFICATIONS AND QUOTE Q10168-21REV3	1		76,156.31
INV 1835	28/06/2022	WESTLINE PLUMBING & DRAINAGE PTY LTD	NORTHAM DEPOT REDEVELOPMENT. INSTALL SEWER EXTENSION AS PER WATERCORP SPECIFICATIONS AND QUOTE Q10168-21REV3	1	76,156.31	
EFT44386	22/07/2022	WESTWIDE AUTO ELECTRICS AND AIR CONDITIONING	FN1906 - N10734 REMOVE INTERNAL AMBER BEACON LIGHTS	1		577.25
INV INV -13730/06/2022		WESTWIDE AUTO ELECTRICS AND AIR CONDITIONING	FN1906 - N10734 REMOVE INTERNAL AMBER BEACON LIGHTS	1	577.25	
EFT44387	22/07/2022	WHEATBELT NATURAL RESOURCE MANAGEMENT	MAINTENANCE OF NORTHAM CEMETERY AS PER C.201920-17, 21/06 - 30/6/2022	1		3,658.13
INV 003013604/07/2022		WHEATBELT NATURAL RESOURCE MANAGEMENT	MAINTENANCE OF NORTHAM CEMETERY AS PER C.201920-17, 21/06 - 30/6/2022	1	3,658.13	
EFT44388	22/07/2022	WOODLANDS DISTRIBUTORS PTY LTD	EPI-OXO300 - DEGRADABLE SINGLE/GUSSETT BAG - 5 x CARTONS, 300 BAGS PER ROLL	1		632.50
INV NTM1-014/07/2022		WOODLANDS DISTRIBUTORS PTY LTD	EPI-OXO300 - DEGRADABLE SINGLE/GUSSETT BAG - 5 x CARTONS, 300 BAGS PER ROLL	1	632.50	
EFT44389	26/07/2022	WCP CIVIL PTY LTD	RESEALING WORK OF PARKER STREET / FORWARD ST, NORTHAM AS PER CONTRACT C.202122-05. - PROGRESS CLAIM 2	1		176,497.29
INV 27204 30/06/2022		WCP CIVIL PTY LTD	RESEALING WORK OF PARKER STREET / FORWARD ST, NORTHAM AS PER CONTRACT C.202122-05. - PROGRESS CLAIM 2	1	176,497.29	
EFT44390	28/07/2022	ABBOTTS FORGE	REPAIR DECK OF JOHN DEERE MOWER	1		125.00

Ordinary Council Meeting Minutes  
17 August 2022

Date: 01/08/2022  
Time: 9:17:37AM

Shire of Northam

USER: Louise Harris  
PAGE: 49/13

Cheque /EFT No	Date	Name	Invoice Description	Bank Code	INV Amount	Amount
INV 000052121	07/2022	ABBOTTS FORGE	REPAIR DECK OF JOHN DEERE MOWER	1	125.00	
EFT44391	28/07/2022	ALEXANDRA LEE MACKENZIE	REFUND OF INFRASTRUCTURE BOND - NO DAMAGE	1		1,000.00
INV T1333	28/07/2022	ALEXANDRA LEE MACKENZIE	REFUND OF INFRASTRUCTURE BOND - NO DAMAGE	1	1,000.00	
EFT44392	28/07/2022	AMPAC DEBT RECOVERY (WA) P/L	DEBT RECOVERY FOR PERIOD ENDING 15 JULY 2022	1		989.87
INV 85979	21/07/2022	AMPAC DEBT RECOVERY (WA) P/L	DEBT RECOVERY FOR PERIOD ENDING 15 JULY 2022	1	989.87	
EFT44393	28/07/2022	ANDY'S PLUMBING SERVICE	BAKERS HILL HOOPER PARK. REPAIR LEAKING TAP AT FRONT OF PARK.	1		4,010.60
INV A19351	19/07/2022	ANDY'S PLUMBING SERVICE	KILLARA. INVESTIGATE SEWER LEAK AND CLEAN UP.	1	258.50	
INV A19350	19/07/2022	ANDY'S PLUMBING SERVICE	KURINGAI VILLAGE UNIT 2. REPAIR BATHROOM DRAIN NOT DRAINING PROPERLY..	1	499.40	
INV A19349	19/07/2022	ANDY'S PLUMBING SERVICE	KILLARA RESPITE CARE. BOARD UP DOOR AFTER BREAK IN FRIDAY NIGHT.	1	317.90	
INV A19352	19/07/2022	ANDY'S PLUMBING SERVICE	YOUTH PARK TOILETS. REPAIR BROKEN SINK IN ACCESSIBLE TOILETS AND UNBLOCK OTHER SINK.	1	1,413.50	
INV A19353	25/07/2022	ANDY'S PLUMBING SERVICE	BAKERS HILL HOOPER PARK. REPAIR LEAKING TAP AT FRONT OF PARK.	1	1,521.30	
EFT44394	28/07/2022	APPLIED INDUSTRIAL TECHNOLOGIES T/A NORTHAM BEARINGS	SILVER GRAFE A/SEIZE LB8150 LOCTITE	1		47.60
INV 697804225	07/2022	APPLIED INDUSTRIAL TECHNOLOGIES T/A NORTHAM BEARINGS	SILVER GRAFE A/SEIZE LB8150 LOCTITE	1	47.60	
EFT44395	28/07/2022	AUSTRALASIAN PERFORMING RIGHT ASSOCIATION LTD T/A S ONEMUSIC AUSTRALIA	MUSIC FOR COUNCIL S - RURAL	1		1,586.68
INV 262528	02/07/2022	AUSTRALASIAN PERFORMING RIGHT ASSOCIATION LTD T/A S ONEMUSIC AUSTRALIA	MUSIC FOR COUNCIL S - RURAL	1	1,586.68	
EFT44396	28/07/2022	AUSTRALIAN TAXATION OFFICE - PAYG	PAYG FOR PAY WEEK ENDING 19/07/2022	1		60,999.70
INV PAYG 121	07/2022	AUSTRALIAN TAXATION OFFICE - PAYG	PAYG FOR PAY WEEK ENDING 19/07/2022	1	60,097.70	
INV PAYG 1	25/07/2022	AUSTRALIAN TAXATION OFFICE - PAYG	PAYG FOR PAY WEEK ENDING 19/07/2022 INTERIM (DAVID EMERY)	1	902.00	

Ordinary Council Meeting Minutes  
17 August 2022



Date: 01/08/2022  
Time: 9:17:37AM

Shire of Northam

USER: Louise Harris  
PAGE: 50 10

Cheque /EFT No	Date	Name	Invoice Description	Bank Code	INV Amount	Amount
EFT44397	28/07/2022	AVON SERVICE SPECIALISTS	CHECK AND SERVICE VEHICLE - FORD RANGER N79 - 115,400KM	1		373.45
INV 23597	11/07/2022	AVON SERVICE SPECIALISTS	CHECK AND SERVICE VEHICLE - FORD RANGER N79 - 115,400KM	1	373.45	
EFT44398	28/07/2022	AVON VALLEY ARTS SOCIETY (INC)	ART WORKS SOLD FOR COMMISSION - VISITORS CENTRE	1		923.81
INV 1028	19/07/2022	AVON VALLEY ARTS SOCIETY (INC)	ART WORKS SOLD FOR COMMISSION - VISITORS CENTRE	1	923.81	
EFT44399	28/07/2022	AVON VALLEY TOYOTA	PN2018 - N10938 - VIN - MR0CB3DB005660578 - PLEASE CONDUCT THE 20,000KM SERVICE	1		394.89
INV JC1400623/06/2022	28/07/2022	AVON VALLEY TOYOTA	PN2018 - N10938 - VIN - MR0CB3DB005660578 - PLEASE CONDUCT THE 20,000KM SERVICE	1	394.89	
EFT44400	28/07/2022	BEAZLEY FENCING - DE JEZERSKI T/AS	TO SUPPLY AND INSTALL 48M OF CHAIN MESH FENCING AT 1800MM HIGH TO ENCLOSE LEAN-TO AND YARD, INCLUDING SINGLE ACCESS GATE AT 1200MM WIDE AND DOUBLE GATES AT 3.5M WIDE. CHAIN MESH PLAIN KNUCKLE/BARB MESH (SPIKE TOP MESH), GALVANIZED POSTS, CAPS, FITTINGS AND HORIZONTAL STAYS FOR THE GATES. CUSTOM GATES WITH KNUCKLE/BARB MESH, BLACK PVC COATED MESH AND WIRE ON FENCE AND GATES WITH GALVANIZED POSTS AND FITTINGS. AS PER QUOTE 00000087	1		8,360.00
INV 000000922/07/2022	28/07/2022	BEAZLEY FENCING - DE JEZERSKI T/AS	TO SUPPLY AND INSTALL 48M OF CHAIN MESH FENCING AT 1800MM HIGH TO ENCLOSE LEAN-TO AND YARD, INCLUDING SINGLE ACCESS GATE AT 1200MM WIDE AND DOUBLE GATES AT 3.5M WIDE. CHAIN MESH PLAIN KNUCKLE/BARB MESH (SPIKE TOP MESH), GALVANIZED POSTS, CAPS, FITTINGS AND HORIZONTAL STAYS FOR THE GATES. CUSTOM GATES WITH KNUCKLE/BARB MESH, BLACK PVC COATED MESH AND WIRE ON FENCE AND GATES WITH GALVANIZED POSTS AND FITTINGS. AS PER QUOTE 00000087	1	8,360.00	
EFT44401	28/07/2022	BOYLE INDUSTRIES PTY LTD	STOCK PURCHASES MUN	1		350.29
INV 333784	14/07/2022	BOYLE INDUSTRIES PTY LTD	STOCK PURCHASES MUN	1	350.29	

Ordinary Council Meeting Minutes  
17 August 2022



Date: 01/08/2022  
Time: 9:17:37AM

Shire of Northam

USER: Louise Harris  
PAGE: 51 13

Cheque /EFT No	Date	Name	Invoice Description	Bank Code	INV Amount	Amount
EFT44402	28/07/2022	BUNNINGS BUILDING SUPPLIES P/L	PLANT-LAVENDER 175MM WINTER LACE	1		727.96
			PLANT-LAVENDER 140MM WINTER LACE			
INV 2182/9918/07/2022		BUNNINGS BUILDING SUPPLIES P/L	5 X BOLLARDS AND 30M ORANGE FLAG ROPING	1	115.00	
INV 2182/9918/07/2022		BUNNINGS BUILDING SUPPLIES P/L	5 x BOLLARDS	1	113.58	
INV 2182/0019/07/2022		BUNNINGS BUILDING SUPPLIES P/L	30M X ORANGE ROPE FLAGGING			
INV 2182/0019/07/2022		BUNNINGS BUILDING SUPPLIES P/L	4MM ADAPTORS FOR RETIC	1	22.45	
INV 2182/0019/07/2022		BUNNINGS BUILDING SUPPLIES P/L	FLUG KINETIC 50MM BASIN BATH BRASS 403104 CHAIN	1	19.12	
INV 2182/0019/07/2022		BUNNINGS BUILDING SUPPLIES P/L	TWIST ZENITH 1.6MMX2.5M MATTE BLACK JTL1630			
INV 2182/0019/07/2022		BUNNINGS BUILDING SUPPLIES P/L	ADMIN BUILDING. SUPPLY 3 X TOILET SEATS.	1	126.60	
INV 2182/0020/07/2022		BUNNINGS BUILDING SUPPLIES P/L	DISC CUTTING MAKITA 115X1X22.23 INOX CUT 12PK x 2	1	28.32	
INV 2182/0020/07/2022		BUNNINGS BUILDING SUPPLIES P/L	PLANT-LAVENDER 175MM WINTER LACE	1	302.89	
			PLANT-LAVENDER 140MM WINTER LACE			
EFT44403	28/07/2022	CENTRAL MOBILE MECHANICAL REPAIRS	FLOAT HIRE	1		1,419.00
INV 000040819/07/2022		CENTRAL MOBILE MECHANICAL REPAIRS	FLOAT HIRE	1	1,419.00	
EFT44404	28/07/2022	CHARLES SERVICE COMPANY	CLEANING OF SHIRE OF NORTHAM FACILITIES C.2021-04	1		7,294.74
			- 20/6/2022 - 17/7/2022			
INV 000348820/04/2022		CHARLES SERVICE COMPANY	C.202021-04- VO1 - WEEKLY CLEANING FOR WUNDOWIE	1	1,736.35	
			OVAL TOILETS 7X A WEEK AS PER QUOTE - 21/3/2022 -			
			17/4/2022			
INV 000349722/05/2022		CHARLES SERVICE COMPANY	C.202021-04- VO1 - WEEKLY CLEANING FOR WUNDOWIE	1	1,916.75	
			OVAL TOILETS 7X A WEEK AS PER QUOTE - 18/04/2022 -			
			22/05/2022			
INV 000350520/06/2022		CHARLES SERVICE COMPANY	C.202021-04- VO1 - WEEKLY CLEANING FOR WUNDOWIE	1	1,533.40	
			OVAL TOILETS 7X A WEEK AS PER QUOTE - 23 MAY 2022			
			- 19 JUNE 2022			
INV 000351130/06/2022		CHARLES SERVICE COMPANY	CREDIT DUPLICATE INVOICE 00034555 / CREDIT	1	-6,516.95	
			OVERCHARGE ON INVOICE 00034597 / 00034679 / 00034794			
INV 000351520/07/2022		CHARLES SERVICE COMPANY	CLEANING OF SHIRE OF NORTHAM FACILITIES C.2021-04	1	8,625.19	
			- 20/6/2022 - 17/7/2022			
EFT44405	28/07/2022	CLARK EQUIPMENT	FN0916 - CROWD BUCKET RAM - PART NUMBER 7117174	1		2,192.91
			CYLINDER AS QUOTED			
INV 082454130/05/2022		CLARK EQUIPMENT	FN0916 - CROWD BUCKET RAM - PART NUMBER 7117174	1	2,192.91	
			CYLINDER AS QUOTED			

Ordinary Council Meeting Minutes  
17 August 2022



Date: 01/08/2022  
Time: 9:17:37AM

Shire of Northam

USER: Louise Harris  
PAGE: 52/10

Cheque /EFT No	Date	Name	Invoice Description	Bank Code	INV Amount	Amount
EFT44406	28/07/2022	CLOUD COLLECTIONS PTY LTD	REFUND OF PAYMENT MADE IN ERROR	1		350.00
INV CY 210721	07/2022	CLOUD COLLECTIONS PTY LTD	REFUND OF PAYMENT MADE IN ERROR	1	350.00	
EFT44407	28/07/2022	COMISKEY'S CONTRACTING PTY LTD	CONSTRUCITON OF NORTHAM WASTE TRANSFER FACILITY AS PER CONTRACT C.202021-26. - PROGRESS CLAIM 10	1		51,977.08
INV 220702	08/07/2022	COMISKEY'S CONTRACTING PTY LTD	CONSTRUCITON OF NORTHAM WASTE TRANSFER FACILITY AS PER CONTRACT C.202021-26. - PROGRESS CLAIM 10	1	51,977.08	
EFT44408	28/07/2022	COUNTRY COMFORT STYLE NORTHAM	ENTERPRISE OFFICE CHAIR BLACK & ARAGON MESH BACK CHAIR WITH ARMS BLACK	1		948.00
INV 17646	21/07/2022	COUNTRY COMFORT STYLE NORTHAM	ENTERPRISE OFFICE CHAIR BLACK & ARAGON MESH BACK CHAIR WITH ARMS BLACK	1	948.00	
EFT44409	28/07/2022	COUNTRYWIDE GROUP	CATCHER FOR HONDA MOWER	1		599.56
INV ACC00120	07/2022	COUNTRYWIDE GROUP	SPRING FOR PN1903	1	9.52	
INV ACC00120	07/2022	COUNTRYWIDE GROUP	CHAINS FOR POLES AW AND CHAINSAW	1	197.00	
INV ACC00122	07/2022	COUNTRYWIDE GROUP	CHAINSAW FULL SERVICE	1	183.04	
INV ACC00123	07/2022	COUNTRYWIDE GROUP	CATCHER FOR HONDA MOWER	1	210.00	
EFT44410	28/07/2022	COUNTRYWIDE POOLS	REFUND OF INFRASTRUCTURE BOND - NO DAMAGE	1		1,020.00
INV T1638	28/07/2022	COUNTRYWIDE POOLS	REFUND OF INFRASTRUCTURE BOND - NO DAMAGE	1	1,020.00	
EFT44411	28/07/2022	CTI SECURITY SERVICES PTY LTD	SHIRE OF NORTHAM SITES - SECURITY ALARM MONITORING FROM 01/08/2022 - 31/08/2022	1		798.07
INV CINS31	19/07/2022	CTI SECURITY SERVICES PTY LTD	SHIRE OF NORTHAM SITES - SECURITY ALARM MONITORING FROM 01/08/2022 - 31/08/2022	1	798.07	
EFT44412	28/07/2022	DCM CARPENTRY & MAINTENANCE	SUPPLY, INSTALL AND PAINTING OF 3 POLES WITH CONCRETE FOOTING AT THE VILLAGE GREEN	1		4,295.50
INV 1421	29/06/2022	DCM CARPENTRY & MAINTENANCE	INSTALL TV INTO FRONT RECEPTION - ADDITIONAL WALL MOUNTING REQUIRED FOR SAFETY AND TO HOLD TV.	1	1,644.50	

Ordinary Council Meeting Minutes  
17 August 2022

Date: 01/08/2022  
Time: 9:17:37AM

Shire of Northam

USER: Louise Harris  
PAGE: 53 13

Cheque /EFT No	Date	Name	Invoice Description	Bank Code	INV Amount	Amount
INV 1420	30/06/2022	DCM CARPENTRY & MAINTENANCE	SUPPLY, INSTALL AND PAINTING OF 3 POLES WITH CONCRETE FOOTING AT THE VILLAGE GREEN	1	2,651.00	
EFT44413	28/07/2022	DRACO AIR PTY LTD	BERT HAWKE PAVILION. REPAIR HEATING IN AIRCONDITIONERS.	1		264.00
INV 14737	19/07/2022	DRACO AIR PTY LTD	BERT HAWKE PAVILION. REPAIR HEATING IN AIRCONDITIONERS.	1	264.00	
EFT44414	28/07/2022	EASTERN METROPOLITAN REGIONAL COUNCIL	EMRC - AVON DESCENT FAMILY FUN DAYS 2022	1		5,500.00
INV EMRC418/07/2022	28/07/2022	EASTERN METROPOLITAN REGIONAL COUNCIL	EMRC - AVON DESCENT FAMILY FUN DAYS 2022	1	5,500.00	
EFT44415	28/07/2022	EQUIFAX AUSTRALASIA WORKFORCE SOLUTIONS PTY LTD	INDIVIDUAL REPORTS FOR NEW VOLUNTEER FIREFIGHTING MEMBERS - AUGUST 2021	1		41.69
INV 149478631/08/2021	28/07/2022	EQUIFAX AUSTRALASIA WORKFORCE SOLUTIONS PTY LTD	INDIVIDUAL REPORTS FOR NEW VOLUNTEER FIREFIGHTING MEMBERS - AUGUST 2021	1	41.69	
EFT44416	28/07/2022	GOODYEAR & DUNLOP TYRES (AUST) PTY LTD	FN1608 - MULTI ROLLER PUNCTURE REPAIR ON SITE WOOTTATING RD	1		430.12
INV 641267420/07/2022	28/07/2022	GOODYEAR & DUNLOP TYRES (AUST) PTY LTD	SUPPLY TUBE FOR MOWER	1	20.00	
INV 641267822/07/2022	28/07/2022	GOODYEAR & DUNLOP TYRES (AUST) PTY LTD	FN1608 - MULTI ROLLER PUNCTURE REPAIR ON SITE WOOTTATING RD	1	376.65	
INV 641267925/07/2022	28/07/2022	GOODYEAR & DUNLOP TYRES (AUST) PTY LTD	FN1307 - REPAIR PUNCTURE	1	33.47	
EFT44417	28/07/2022	GRAFTON ELECTRICS	MINSON AVE STREET LIGHTS. REPLACE BROKEN LIGHTS WITH LED AND GLOBES AS PER QUOTE 122.	1		9,599.70
INV 8822	19/07/2022	GRAFTON ELECTRICS	OLD TOWN ADMIN. INVESTIGATE/REPAIR FRONT AUTOMATIC DOOR OPENING RANDOMLY.	1	209.00	
INV 8798	22/07/2022	GRAFTON ELECTRICS	MINSON AVE STREET LIGHTS. REPLACE BROKEN LIGHTS WITH LED AND GLOBES AS PER QUOTE 122.	1	8,444.70	
INV 8831	22/07/2022	GRAFTON ELECTRICS	MINSON AVE STREET LIGHTS. REPAIR EXTRA LLIGHTS FROM INSPECTION.	1	946.00	
EFT44418	28/07/2022	ID CONSULTING PTY LTD	PROFILE.ID / ATLAS.ID / ECONOMY.ID - SUBSCRIPTION FEE 01/07/2022-30/06/2023	1		19,965.00
INV 000143207/07/2022	28/07/2022	ID CONSULTING PTY LTD	PROFILE.ID / ATLAS.ID / ECONOMY.ID - SUBSCRIPTION FEE 01/07/2022-30/06/2023	1	19,965.00	



Ordinary Council Meeting Minutes  
17 August 2022



Date: 01/08/2022  
Time: 9:17:37AM

Shire of Northam

USER: Louise Harris  
PAGE: 54 10

Cheque /EFT No	Date	Name	Invoice Description	Bank Code	INV Amount	Amount
EFT44419	28/07/2022	INTERFIRE AGENCIES PTY LTD T/A LOVETT FAMILY TRUST	PACIFIC EASION SLIDE TORCH HOLDER B2066146 NIGHTSTICK X-SERIES SAFETY RATED LED TORCH	1		1,522.95
INV 10925	21/07/2022	INTERFIRE AGENCIES PTY LTD T/A LOVETT FAMILY TRUST	PACIFIC EASION SLIDE TORCH HOLDER B2066146 NIGHTSTICK X-SERIES SAFETY RATED LED TORCH	1	1,522.95	
EFT44420	28/07/2022	JEF SALES & SERVICE	HEDGE TRIMMER SERVICE STIHL HS82T	1		84.42
INV 41	21/07/2022	JEF SALES & SERVICE	HEDGE TRIMMER SERVICE STIHL HS82T	1	84.42	
EFT44421	28/07/2022	KAREN ANNBLURTON	CATERING KANGEROO STEW AND DAMPER-NAIDOC EVENT 2022- INGREDIENTS AND LABOUR	1		500.00
INV 15	07/07/2022	KAREN ANNBLURTON	CATERING KANGEROO STEW AND DAMPER-NAIDOC EVENT 2022- INGREDIENTS AND LABOUR	1	500.00	
EFT44422	28/07/2022	KATHY DAVIS	PAYMENT FOR COLLECTION OF STORY - BKB STAGE 2	1		300.00
INV 16	12/07/2022	KATHY DAVIS	PAYMENT FOR COLLECTION OF STORY - BKB STAGE 2	1	300.00	
EFT44423	28/07/2022	KLEENHEAT GAS	GAS FOR NORTHAM SWIMMING POOL - JULY 2022	1		214.20
INV 219693714/07/2022		KLEENHEAT GAS	GAS FOR NORTHAM SWIMMING POOL - JULY 2022	1	214.20	
EFT44424	28/07/2022	LFA FIRST RESPONSE	VENTOLIN INHALER 200 METERED DOSES	1		203.01
INV IN2514612/07/2022		LFA FIRST RESPONSE	VENTOLIN INHALER 200 METERED DOSES	1	203.01	
EFT44425	28/07/2022	LIGHT APPLICATION PTY LTD	SUSPENSION BRIDGE LIGHTING. 5 YEAR RENEWAL FOR PHAROS CLOUD AND 4G CONNECTION.	1		3,573.63
INV 85464	20/07/2022	LIGHT APPLICATION PTY LTD	SUSPENSION BRIDGE LIGHTING. 5 YEAR RENEWAL FOR PHAROS CLOUD AND 4G CONNECTION.	1	3,573.63	
EFT44426	28/07/2022	LOCAL GOVERNMENT PROFESSIONALS AUSTRALIA WA	LOCAL GOVERNMENT PROFESSIONALS MEMBERSHIP RENEWAL FOR COLIN YOUNG	1		531.00
INV 27083	01/07/2022	LOCAL GOVERNMENT PROFESSIONALS AUSTRALIA WA	LOCAL GOVERNMENT PROFESSIONALS MEMBERSHIP RENEWAL FOR COLIN YOUNG	1	531.00	
EFT44427	28/07/2022	LUME BRASSERIE - MADEELA PL T/AS	CATERING - ORDINARY COUNCIL MEETING 20 JULY 2022	1		520.00
INV SHIRE 220/07/2022		LUME BRASSERIE - MADEELA PL T/AS	CATERING - ORDINARY COUNCIL MEETING 20 JULY 2022	1	520.00	
EFT44428	28/07/2022	MALINOWSKI HOLDINGS PTY LTD	RENT FOR 174 FITZGERAL ST (AVON MALL) 01/07/2022-31/07/2022	1		1,145.84

Ordinary Council Meeting Minutes  
17 August 2022



Date: 01/08/2022  
Time: 9:17:37AM

Shire of Northam

USER: Louise Harris  
PAGE: 55 13

Cheque /EFT No	Date	Name	Invoice Description	Bank Code	INV Amount	Amount
INV 000005727/06/2022		MALINOWSKI HOLDINGS PTY LTD	RENT FOR 174 FITZGERAL ST (AVON MALL) 01/07/2022-31/07/2022	1	1,145.84	
EFT44429	28/07/2022	MAYBERRY HAMMOND & CO	LEASE FOR PISTOL CLUB	1		1,302.60
INV 44370	16/06/2022	MAYBERRY HAMMOND & CO	TRANSFER OF LEASE HANGAR 12 TO DAMIAN ODRISCOLL	1	572.00	
INV 44420	13/07/2022	MAYBERRY HAMMOND & CO	LEASE FOR PISTOL CLUB	1	730.60	
EFT44430	28/07/2022	MAYDAY EARTHMOVING / RENTAL - CHIVAS ENTERPRISES T-AS	1 DAY DOZER DRY HIRE / DEMOB	1		2,398.00
INV 82405	01/07/2022	MAYDAY EARTHMOVING / RENTAL - CHIVAS ENTERPRISES T-AS	1 DAY DOZER DRY HIRE / DEMOB	1	2,398.00	
EFT44431	28/07/2022	MINT CIVIL PTY LTD T/AS IMMACU SWEEP	C.201819-12 STREET SWEEPING & GULLY EDUCATION SERVICES (CLEANING TOWN ROADS) / FOOTPATH & VERGE SWEEPING OF CBD FROM 27/6/2022 - 3/7/2022	1		7,801.20
INV N3029	11/07/2022	MINT CIVIL PTY LTD T/AS IMMACU SWEEP	C.201819-12 STREET SWEEPING & GULLY EDUCATION SERVICES (CLEANING TOWN ROADS) / FOOTPATH & VERGE SWEEPING OF CBD FROM 27/6/2022 - 3/7/2022	1	3,900.60	
INV N3030	11/07/2022	MINT CIVIL PTY LTD T/AS IMMACU SWEEP	C.201819-12 STREET SWEEPING & GULLY EDUCATION SERVICES (CLEANING TOWN ROADS) / FOOTPATH & VERGE SWEEPING OF CBD FROM 4/7/2022 - 10/7/2022	1	3,900.60	
EFT44432	28/07/2022	NORTHAM AUTOS PTY LTD T/AS NORTHAM MAZDA & NORTHAM HOLDEN	PN2019 - N9467 - VIN - TSMLYD21S00907326 - PLEASE CONDUCT 20,000KM SERVICE	1		329.00
INV 137842	23/06/2022	NORTHAM AUTOS PTY LTD T/AS NORTHAM MAZDA & NORTHAM HOLDEN	PN2019 - N9467 - VIN - TSMLYD21S00907326 - PLEASE CONDUCT 20,000KM SERVICE	1	329.00	
EFT44433	28/07/2022	NORTHAM DISTRICTS GLASS PTY LTD	PN1305 - 1GZQ718 - ISUZU 2014 TRUCK REQUIRES DRIVERS SIDE WINDOW REPLACEMENT	1		550.00
INV INV-26328/06/2022		NORTHAM DISTRICTS GLASS PTY LTD	PN1305 - 1GZQ718 - ISUZU 2014 TRUCK REQUIRES DRIVERS SIDE WINDOW REPLACEMENT	1	550.00	
EFT44434	28/07/2022	NORTHAM LIQUOR BARONS	STOCK FOR COUNCIL CHAMBERS	1		351.93
INV 385944	20/07/2022	NORTHAM LIQUOR BARONS	STOCK FOR COUNCIL CHAMBERS	1	351.93	
EFT44435	28/07/2022	NORTHAM MOTORS PTY LTD	PN1915 - N11206 - 60,000KM SERVICE	1		610.01
INV 14234661/10/7/2022		NORTHAM MOTORS PTY LTD	PN1915 - N11206 - 60,000KM SERVICE	1	610.01	

Ordinary Council Meeting Minutes  
17 August 2022



Date: 01/08/2022  
Time: 9:17:37AM

Shire of Northam

USER: Louise Harris  
PAGE: 56 10

Cheque /EFT No	Date	Name	Invoice Description	Bank Code	INV Amount	Amount
EFT44436	28/07/2022	NORTHAM TOWING SERVICE	PN2013 - N.4098 - TOYOTA RAV4 PICKUP FROM 86 CHIDLLOW ST NORTHAM, DROP OFF AT AVON VALLEY TOYOTA 32 FITZGERALD ST NORTHAM.	1		80.00
INV 211577	12/07/2022	NORTHAM TOWING SERVICE	PN2013 - N.4098 - TOYOTA RAV4 PICKUP FROM 86 CHIDLLOW ST NORTHAM, DROP OFF AT AVON VALLEY TOYOTA 32 FITZGERALD ST NORTHAM.	1	80.00	
EFT44437	28/07/2022	OFFICEWORKS SUPERSTORES PTY LTD	2 X ACER 15.6" ASPIRE 3 NOTEBOOK CORE I5 8/256GB WIN11 / 2 X JBURROWS 15.6" LAPTOP BAG WITH EXTERNAL ZIP POCKET BLACK / 2 X KEJI 2.4G WIRELESS KEYBOARD AND MOUSE COMBO	1		1,536.95
INV 601305015/06/2022	06/2022	OFFICEWORKS SUPERSTORES PTY LTD	2 X ACER 15.6" ASPIRE 3 NOTEBOOK CORE I5 8/256GB WIN11 / 2 X JBURROWS 15.6" LAPTOP BAG WITH EXTERNAL ZIP POCKET BLACK / 2 X KEJI 2.4G WIRELESS KEYBOARD AND MOUSE COMBO	1	1,536.95	
EFT44438	28/07/2022	PRESTIGE ALARMS	ADMIN BUILDING. SUPPLY AND POST TO SITE 10 X SECURITY FOBS TO REPLACE BROKEN AND LOST UNITS.	1		189.53
INV 519510	20/07/2022	PRESTIGE ALARMS	ADMIN BUILDING. SUPPLY AND POST TO SITE 10 X SECURITY FOBS TO REPLACE BROKEN AND LOST UNITS.	1	189.53	
EFT44439	28/07/2022	PROMOPAL PTY LTD	UMBRELLA CANOPY VILLAGE GREEN BILYA FESTIVAL 2022-MELBOURNE UMBRELLAS-MIX OF COLOURS-DELIVERY BY AUGUST	1		6,377.80
INV INV-14714/06/2022	06/2022	PROMOPAL PTY LTD	UMBRELLA CANOPY VILLAGE GREEN BILYA FESTIVAL 2022-MELBOURNE UMBRELLAS-MIX OF COLOURS-DELIVERY BY AUGUST	1	6,377.80	
EFT44440	28/07/2022	PUBLIC TRANSPORT AUTHORITY	TRAIN TICKET SALES FOR JUNE 2022	1		41.75
INV 399930	30/06/2022	PUBLIC TRANSPORT AUTHORITY	TRAIN TICKET SALES FOR JUNE 2022	1	41.75	
EFT44441	28/07/2022	RONLIEEH PTY LTD T/AS ALL PARTS WA	PN1518 - BELTS FOR FLAIL MOWER	1		141.90
INV SI-0000	20/07/2022	RONLIEEH PTY LTD T/AS ALL PARTS WA	PN1518 - BELTS FOR FLAIL MOWER	1	141.90	
EFT44442	28/07/2022	S&K SPADACCINI FAMILY HOME BUILDERS PL T/AS SIMON SPADACCINI CONSTRUCTION	REFUND OF INFRASTRUCTURE BOND - NO DAMAGE	1		1,020.00

Ordinary Council Meeting Minutes  
17 August 2022



Date: 01/08/2022  
Time: 9:17:37AM

Shire of Northam

USER: Louise Harris  
PAGE: 57/13

Cheque /EFT No	Date	Name	Invoice Description	Bank Code	INV Amount	Amount
INV T1601	28/07/2022	S&K SPADACCINI FAMILY HOME BUILDERS PL T/AS SIMON SPADACCINI CONSTRUCTION	REFUND OF INFRASTRUCTURE BOND - NO DAMAGE	1	1,020.00	
EFT44443	28/07/2022	SHANE ASHMAN	RATES REFUND FOR ASSESSMENT A15588	1		649.69
INV A15588	20/07/2022	SHANE ASHMAN	RATES REFUND FOR ASSESSMENT A15588		376.59	
INV CY 280728/07/2022	28/07/2022	SHANE ASHMAN	REFUND OF LEASE PAYMENT FOR HANGAR 12 - SOLD ON 8/2/2022	1	273.10	
EFT44444	28/07/2022	SHRED-X PTY LTD	DESTRUCTION OF ARCHIVED BOXES	1		314.52
INV 018372030/06/2022	28/07/2022	SHRED-X PTY LTD	DESTRUCTION OF ARCHIVED BOXES	1	314.52	
EFT44445	28/07/2022	SILVER WINGS SENIOR'S CLUB INC.	REFUND SILVER WINGS GROUP FOR THE PURCHASE OF FUEL - WUNDOWIE COMMUNITY BUS	1		40.08
INV 003910118/07/2022	28/07/2022	SILVER WINGS SENIOR'S CLUB INC.	REFUND SILVER WINGS GROUP FOR THE PURCHASE OF FUEL - WUNDOWIE COMMUNITY BUS	1	40.08	
EFT44446	28/07/2022	SONTEC INTEGRATED SYSTEMS	EMERGENCY REPAIR TO SECURITY DOOR TIMING	1		1,035.21
INV 18896	12/07/2022	SONTEC INTEGRATED SYSTEMS	EMERGENCY REPAIR TO SECURITY DOOR TIMING	1	1,035.21	
EFT44447	28/07/2022	SPORTSPOWER NORTHAM H & H JOUBERT	WHISTLES FOR STAFF TO UMPIRE SOCIAL SPORTS	1		100.00
INV 22-000021/07/2022	28/07/2022	SPORTSPOWER NORTHAM H & H JOUBERT	WHISTLES FOR STAFF TO UMPIRE SOCIAL SPORTS	1	10.00	
INV 22-000021/07/2022	28/07/2022	SPORTSPOWER NORTHAM H & H JOUBERT	WHISTLES FOR STAFF TO UMPIRE SOCIAL SPORTS	1	90.00	
EFT44448	28/07/2022	SYNERGY	168614990 STREETLIGHTING - 25/05/2022 to 24/06/2022	1		42,657.36
INV 915241604/07/2022	28/07/2022	SYNERGY	915241640 AUXILLARY LIGHTING - 28/05/2022 to 27/07/2022	1	144.24	
INV 168614904/07/2022	28/07/2022	SYNERGY	168614990 STREETLIGHTING - 25/05/2022 to 24/06/2022	1	25,395.98	
INV 293110713/07/2022	28/07/2022	SYNERGY	293110730 BILYA KOORT BOODJA - 08/06/2022 to 12/07/2022		1,575.67	
INV 361669313/07/2022	28/07/2022	SYNERGY	361669310 RECREATION PRECINCT - NORTHAM AQUATIC FACILITY - 08/06/2022 to 12/07/2022		10,051.24	
INV 357547718/07/2022	28/07/2022	SYNERGY	357547710 MOUNT OMMANNEY - CCTV - 17/05/2022 to 13/07/2022		132.69	
INV 941453220/07/2022	28/07/2022	SYNERGY	941453230 GRASS VALLEY BFB FIRE SHED - 20/05/2022 to 18/07/2022		301.22	

Ordinary Council Meeting Minutes  
17 August 2022



Date: 01/08/2022  
Time: 9:17:37AM

Shire of Northam

USER: Louise Harris  
PAGE: 58 10

Cheque /EFT No	Date	Name	Invoice Description	Bank Code	INV Amount	Amount
INV 357547321/07/2022		SYNERGY	357547330 APEX PARK TOILETS - 25/05/2022 to 19/07/2022		182.88	
INV 136537721/07/2022		SYNERGY	136537740 AIRPORT - 16/06/2022 to 20/07/2022		1,515.67	
INV 811029421/07/2022		SYNERGY	811029470 WUNDOWIE SWIMMING POOL - 29/06/2022 to 20/07/2022		611.57	
INV 361670221/07/2022		SYNERGY	361670250 NORTHAM LIBRARY - 16/06/2022 to 20/07/2022		521.00	
INV 361333121/07/2022		SYNERGY	361333180 SUSPENSION BRIDGE LIGHTING - 25/05/2022 to 19/07/2022		358.44	
INV 357549621/07/2022		SYNERGY	357549690 KILLARA DAYCARE CENTRE - COTTAGE - 16/06/2022 to 20/07/2022		1,587.75	
INV 357547421/07/2022		SYNERGY	357547470 MORBY COTTAGE - 28/06/2022 to 18/07/2022		113.11	
INV 157822522/07/2022		SYNERGY	157822560 IRISHTOWN BFB - 24/05/2022 to 21/07/2022		165.90	
EFT44449	28/07/2022	THE BOOK SHED	PAINT LETTERING ON TO CONCRETE AT BERNARD PARK	1		1,309.00
INV INV-22130/06/2022		THE BOOK SHED	PAINT LETTERING ON TO CONCRETE AT BERNARD PARK	1	1,309.00	
EFT44450	28/07/2022	THE PRINT SHOP BUNBURY	NO UNAUTHORISED PARKING, PRESS GREEN BUTTON X 2	1		299.20
INV 151447830/06/2022		THE PRINT SHOP BUNBURY	SIGNAGE FOR NORTHAM POOL NO UNAUTHORISED PARKING, PRESS GREEN BUTTON X 2	1	299.20	
EFT44451	28/07/2022	THE WORKWEAR GROUP	UNIFORMS - LOUISE HARRIS	1		1,029.55
INV 137334514/01/2022		THE WORKWEAR GROUP	UNIFORM ITEMS FOR WASTE MANAGEMENT OFFICER ANNEMAREE JENSEN - 1 X SKU CAT3CA SIZE 14 AND IN BLACK	1	121.00	
INV 140657910/06/2022		THE WORKWEAR GROUP	UNIFORMS - BOBBI JO	1	247.59	
INV 140938321/06/2022		THE WORKWEAR GROUP	UNIFORMS - LEE MCLELLAN	1	132.86	
INV 141641708/07/2022		THE WORKWEAR GROUP	UNIFORMS - ALISON QUIN	1	183.49	
INV 141771715/07/2022		THE WORKWEAR GROUP	UNIFORMS - LOUISE HARRIS	1	344.61	

Ordinary Council Meeting Minutes  
17 August 2022



Date: 01/08/2022  
Time: 9:17:37AM

Shire of Northam

USER: Louise Harris  
PAGE: 59 13

Cheque /EFT No	Date	Name	Invoice Description	Bank Code	INV Amount	Amount
EFT44452	28/07/2022	THYLACTINE DESIGN & PROJECT MANAGEMENT	COLLECTION OF STORIES	1		4,400.00
INV 201035030/06/2022		THYLACTINE DESIGN & PROJECT MANAGEMENT	COLLECTION OF STORIES	1	4,400.00	
EFT44453	28/07/2022	TOLL - IPEC PTY LTD T/AS	TOLL FREIGHT - POOL / CESM / HEALTH - JUNE 2022	1		56.54
INV 0550-S326/06/2022		TOLL - IPEC PTY LTD T/AS	TOLL FREIGHT - POOL / CESM / HEALTH - JUNE 2022	1	56.54	
EFT44454	28/07/2022	WA FARM SHOP - TAA GROUP HOLDINGS PTY LTD T/AS	BAILEYS VITA PLANT 200 LITRES	1		2,346.74
INV 100000022/07/2022		WA FARM SHOP - TAA GROUP HOLDINGS PTY LTD T/AS	BAILEYS VITA PLANT 200 LITRES	1	2,346.74	
EFT44455	28/07/2022	WAY SIGNS	WHITE REFLECTIVE 75MM NUMBERS FOR RURAL SIGNAGE - 4, 5 & 8	1		264.00
INV INV-28927/03/2022		WAY SIGNS	WHITE REFLECTIVE 75MM NUMBERS FOR RURAL SIGNAGE - 4, 5 & 8	1	264.00	
EFT44456	28/07/2022	WEST OZ WILDLIFE	WILDLIFE EXHIBIT/STALL BILYA FETSIVAL 12TH AUGUST 2022- 3HRS - 5PM TILL 8PM 2 KEEPERS PYTHONS, BOB TAILED LIZARDS, BLUE TONGUES, FRILLED NECKED LIZARDS, KOALA. SUPPLY OUR BRANDED 6 X 3 MARQUEE, WITH ACTIVITY TABLES AND TOUCH AND FEEL TRAYS.	1		1,127.50
INV 3097	19/07/2022	WEST OZ WILDLIFE	WILDLIFE EXHIBIT/STALL BILYA FETSIVAL 12TH AUGUST 2022- 3HRS - 5PM TILL 8PM 2 KEEPERS PYTHONS, BOB TAILED LIZARDS, BLUE TONGUES, FRILLED NECKED LIZARDS, KOALA. SUPPLY OUR BRANDED 6 X 3 MARQUEE, WITH ACTIVITY TABLES AND TOUCH AND FEEL TRAYS.	1	1,127.50	
EFT44457	28/07/2022	WESTWIDE AUTO ELECTRICS AND AIR CONDITIONING	GRASS VALLEY 4.4 - REPLACE BATTERIES WITH AGM BATTERIES TEST ELECTRICAL AND CHARGING SYSTEM FOR COMPLIANCE	1		2,100.00
INV INV136 17/06/2022		WESTWIDE AUTO ELECTRICS AND AIR CONDITIONING	GRASS VALLEY 4.4 - REPLACE BATTERIES WITH AGM BATTERIES TEST ELECTRICAL AND CHARGING SYSTEM FOR COMPLIANCE	1	1,250.00	

Ordinary Council Meeting Minutes  
17 August 2022



Date: 01/08/2022  
Time: 9:17:37AM

Shire of Northam

USER: Louise Harris  
PAGE: 60/10

Cheque /EFT No	Date	Name	Invoice Description	Bank Code	INV Amount	Amount
INV INV-13617/06/2022		WESTWIDE AUTO ELECTRICS AND AIR CONDITIONING	GRASS VALLEY 4.4 - REPLACE BATTERIES WITH AGM BATTERIES TEST ELECTRICAL AND CHARGING SYSTEM FOR COMPLIANCE	1	87.50	
INV INV-13730/06/2022		WESTWIDE AUTO ELECTRICS AND AIR CONDITIONING	DIAGNOSE AND REPAIR/REPLACE BATTERIES ON 3.4U	1	762.50	
EFT44458	28/07/2022	WHEATBELT OFFICE & BUSINESS MACHINES (WOBM)	1 X MICROSOFT WIRELESS KEYBOARD + MOUSE COMBO	1		87.00
INV 29106	05/07/2022	WHEATBELT OFFICE & BUSINESS MACHINES (WOBM)	1 X MICROSOFT WIRELESS KEYBOARD + MOUSE COMBO	1	43.50	
INV 29114	05/07/2022	WHEATBELT OFFICE & BUSINESS MACHINES (WOBM)	1 X MICROSOFT WIRELESS KEYBOARD + MOUSE COMBO	1	43.50	
EFT44459	28/07/2022	WHEATBELT SERVICES PTY LTD	SIGNAGE - MULUCKINE RD / OLIVER RD / KEEP LEFT / DO NOT FEED BIRDS / BLACK SPOT	1		785.40
INV 000003318/07/2022		WHEATBELT SERVICES PTY LTD	SIGNAGE - MULUCKINE RD / OLIVER RD / KEEP LEFT / DO NOT FEED BIRDS / BLACK SPOT	1	785.40	
EFT44460	28/07/2022	WINPRO ELECTRICAL	SUPPLY/INSTALL CCTV AT NORTHAM ANIMAL POUND	1		2,189.00
INV INV-19327/06/2022		WINPRO ELECTRICAL	SUPPLY/INSTALL CCTV AT NORTHAM ANIMAL POUND	1	2,189.00	
DD17966.1	13/07/2022	BANKWEST	BRENDAN RUTTER MASTERCARD 22/04/2022 TO 23/05/2022	1		605.54
INV B RUTT13/07/2022		BANKWEST	BRENDAN RUTTER MASTERCARD 22/04/2022 TO 23/05/2022	1	605.54	
DD18040.1	13/07/2022	BANKWEST	BRENDAN RUTTER MASTERCARD 22/04/2022 TO 23/05/2022	1		-605.54
INV B RUTT13/07/2022		BANKWEST	BRENDAN RUTTER MASTERCARD 22/04/2022 TO 23/05/2022	1	-605.54	
DD18054.1	01/07/2022	TENNANT AUSTRALIA	RECREATION CENTRE LEASE FEE CLEANING EQUIPMENT JULY 2022 FINANCE & LEASE IW8119996100	1		573.75
INV JULY 2001/07/2022		TENNANT AUSTRALIA	RECREATION CENTRE LEASE FEE CLEANING EQUIPMENT JULY 2022 FINANCE & LEASE IW8119996100	1	573.75	
DD18065.1	05/07/2022	AWARE SUPER	PAYROLL DEDUCTIONS	1		29,157.58
INV SUPER 05/07/2022		AWARE SUPER	SUPERANNUATION CONTRIBUTIONS	1	24,654.64	

Ordinary Council Meeting Minutes  
17 August 2022



Date: 01/08/2022  
Time: 9:17:37AM

Shire of Northam

USER: Louise Harris  
PAGE: 61 13

Cheque /EFT No	Date	Name	Invoice Description	Bank Code	INV Amount	Amount
INV DEDUC	05/07/2022	AWARE SUPER	PAYROLL DEDUCTIONS	1	2,824.89	
INV DEDUC	05/07/2022	AWARE SUPER	PAYROLL DEDUCTIONS	1	40.40	
INV DEDUC	05/07/2022	AWARE SUPER	PAYROLL DEDUCTIONS	1	40.40	
INV DEDUC	05/07/2022	AWARE SUPER	PAYROLL DEDUCTIONS	1	25.00	
INV DEDUC	05/07/2022	AWARE SUPER	PAYROLL DEDUCTIONS	1	1,100.00	
INV DEDUC	05/07/2022	AWARE SUPER	PAYROLL DEDUCTIONS	1	84.69	
INV DEDUC	05/07/2022	AWARE SUPER	PAYROLL DEDUCTIONS	1	146.88	
INV DEDUC	05/07/2022	AWARE SUPER	PAYROLL DEDUCTIONS	1	67.31	
INV DEDUC	05/07/2022	AWARE SUPER	PAYROLL DEDUCTIONS	1	102.37	
INV DEDUC	05/07/2022	AWARE SUPER	PAYROLL DEDUCTIONS	1	71.00	
DD18065.2	05/07/2022	ONEPATH	SUPERANNUATION CONTRIBUTIONS	1		278.76
INV SUPER	05/07/2022	ONEPATH	SUPERANNUATION CONTRIBUTIONS	1	278.76	
DD18065.3	05/07/2022	UNISUPER	PAYROLL DEDUCTIONS	1		1,297.69
INV SUPER	05/07/2022	UNISUPER	SUPERANNUATION CONTRIBUTIONS	1	668.15	
INV DEDUC	05/07/2022	UNISUPER	PAYROLL DEDUCTIONS	1	169.54	
INV DEDUC	05/07/2022	UNISUPER	PAYROLL DEDUCTIONS	1	460.00	
DD18065.4	05/07/2022	THE TRUSTEE FOR A E & DL WILLIAMS SUPER FUND	SUPERANNUATION CONTRIBUTIONS	1		204.51
INV SUPER	05/07/2022	THE TRUSTEE FOR A E & DL WILLIAMS SUPER FUND	SUPERANNUATION CONTRIBUTIONS	1	204.51	
DD18065.5	05/07/2022	PLUM SUPERANNUATION FUND	PAYROLL DEDUCTIONS	1		536.56
INV SUPER	05/07/2022	PLUM SUPERANNUATION FUND	SUPERANNUATION CONTRIBUTIONS	1	405.69	
INV DEDUC	05/07/2022	PLUM SUPERANNUATION FUND	PAYROLL DEDUCTIONS	1	130.87	
DD18065.6	05/07/2022	COLONIAL FIRST STATE SUPERANNUATION	SUPERANNUATION CONTRIBUTIONS	1		253.50



Ordinary Council Meeting Minutes  
17 August 2022



Date: 01/08/2022  
Time: 9:17:37AM

Shire of Northam

USER: Louise Harris  
PAGE: 62 10

Cheque /EFT No	Date	Name	Invoice Description	Bank Code	INV Amount	Amount
INV SUPER	05/07/2022	COLONIAL FIRST STATE SUPERANNUATION	SUPERANNUATION CONTRIBUTIONS	1	253.50	
DD18065.7	05/07/2022	HESTA SUPER FUND	SUPERANNUATION CONTRIBUTIONS	1		471.83
INV SUPER	05/07/2022	HESTA SUPER FUND	SUPERANNUATION CONTRIBUTIONS	1	471.83	
DD18065.8	05/07/2022	CATHOLIC SUPER	SUPERANNUATION CONTRIBUTIONS	1		130.32
INV SUPER	05/07/2022	CATHOLIC SUPER	SUPERANNUATION CONTRIBUTIONS	1	130.32	
DD18065.9	05/07/2022	AUSTRALIAN CATHOLIC SUPPERANNUATION RETIREMENT FUND	SUPERANNUATION CONTRIBUTIONS	1		366.91
INV SUPER	05/07/2022	AUSTRALIAN CATHOLIC SUPPERANNUATION RETIREMENT FUND	SUPERANNUATION CONTRIBUTIONS	1	366.91	
DD18090.1	12/07/2022	BANKWEST	JASON WHITEAKER MASTERCARD 24/05/2022 TO 22/06/2022	1		5,290.52
INV B RUTT	12/07/2022	BANKWEST	ERENDAN RUTTER MASTERCARD 24/05/22 TO 22/06/22	1	79.05	
INV S PATTE	12/07/2022	BANKWEST	SCOTT PATTERSON MASTERCARD 24/05/22 TO 22/06/22	1	159.00	
INV J METC	12/07/2022	BANKWEST	JOANNE METCALF MASTERCARD 24/05/22 TO 22/06/22	1	2,091.99	
INV C YOU	12/07/2022	BANKWEST	COLIN YOUNG MASTERCARD 24/05/2022 TO 22/06/2022	1	2,045.98	
INV C HUNT	12/07/2022	BANKWEST	CHADD HUNT MASTER CARD 24/05/2022 TO 22/06/2022	1	239.00	
INV J WHIT	12/07/2022	BANKWEST	JASON WHITEAKER MASTERCARD 24/05/2022 TO 22/06/2022	1	675.50	
DD18124.1	19/07/2022	AWARE SUPER	PAYROLL DEDUCTIONS	1		28,373.60
INV SUPER	19/07/2022	AWARE SUPER	SUPERANNUATION CONTRIBUTIONS	1	23,604.43	
INV DEDUC	19/07/2022	AWARE SUPER	PAYROLL DEDUCTIONS	1	2,741.98	
INV DEDUC	19/07/2022	AWARE SUPER	PAYROLL DEDUCTIONS	1	41.09	
INV DEDUC	19/07/2022	AWARE SUPER	PAYROLL DEDUCTIONS	1	41.09	
INV DEDUC	19/07/2022	AWARE SUPER	PAYROLL DEDUCTIONS	1	25.00	
INV DEDUC	19/07/2022	AWARE SUPER	PAYROLL DEDUCTIONS	1	1,400.00	
INV DEDUC	19/07/2022	AWARE SUPER	PAYROLL DEDUCTIONS	1	99.29	

Ordinary Council Meeting Minutes  
17 August 2022



Date: 01/08/2022  
Time: 9:17:37AM

Shire of Northam

USER: Louise Harris  
PAGE: 63 13

Cheque /EFT No	Date	Name	Invoice Description	Bank Code	INV Amount	Amount
INV DEDUC	19/07/2022	AWARE SUPER	PAYROLL DEDUCTIONS	1	208.40	
INV DEDUC	19/07/2022	AWARE SUPER	PAYROLL DEDUCTIONS	1	67.31	
INV DEDUC	19/07/2022	AWARE SUPER	PAYROLL DEDUCTIONS	1	114.13	
INV DEDUC	19/07/2022	AWARE SUPER	PAYROLL DEDUCTIONS	1	30.88	
DD18124.2	19/07/2022	ONEPATH	SUPERANNUATION CONTRIBUTIONS	1		276.42
INV SUPER	19/07/2022	ONEPATH	SUPERANNUATION CONTRIBUTIONS	1	276.42	
DD18124.3	19/07/2022	UNISUPER	PAYROLL DEDUCTIONS	1		1,143.24
INV SUPER	19/07/2022	UNISUPER	SUPERANNUATION CONTRIBUTIONS	1	501.04	
INV DEDUC	19/07/2022	UNISUPER	PAYROLL DEDUCTIONS	1	182.20	
INV DEDUC	19/07/2022	UNISUPER	PAYROLL DEDUCTIONS	1	460.00	
DD18124.4	19/07/2022	THE TRUSTEE FOR A E & DL WILLIAMS SUPER FUND	SUPERANNUATION CONTRIBUTIONS	1		235.15
INV SUPER	19/07/2022	THE TRUSTEE FOR A E & DL WILLIAMS SUPER FUND	SUPERANNUATION CONTRIBUTIONS	1	235.15	
DD18124.5	19/07/2022	PLUM SUPERANNUATION FUND	PAYROLL DEDUCTIONS	1		529.07
INV SUPER	19/07/2022	PLUM SUPERANNUATION FUND	SUPERANNUATION CONTRIBUTIONS	1	400.03	
INV DEDUC	19/07/2022	PLUM SUPERANNUATION FUND	PAYROLL DEDUCTIONS	1	129.04	
DD18124.6	19/07/2022	COLONIAL FIRST STATE SUPERANNUATION	SUPERANNUATION CONTRIBUTIONS	1		253.50
INV SUPER	19/07/2022	COLONIAL FIRST STATE SUPERANNUATION	SUPERANNUATION CONTRIBUTIONS	1	253.50	
DD18124.7	19/07/2022	HESTA SUPER FUND	SUPERANNUATION CONTRIBUTIONS	1		483.94
INV SUPER	19/07/2022	HESTA SUPER FUND	SUPERANNUATION CONTRIBUTIONS	1	483.94	
DD18124.8	19/07/2022	CATHOLIC SUPER	SUPERANNUATION CONTRIBUTIONS	1		155.87
INV SUPER	19/07/2022	CATHOLIC SUPER	SUPERANNUATION CONTRIBUTIONS	1	155.87	

Ordinary Council Meeting Minutes  
17 August 2022



Date: 01/08/2022  
Time: 9:17:37AM

Shire of Northam

USER: Louise Harris  
PAGE: 64 10

Cheque /EFT No	Date	Name	Invoice Description	Bank Code	INV Amount	Amount
DD18124.9	19/07/2022	AUSTRALIAN CATHOLIC SUPERANNUATION RETIREMENT FUND	SUPERANNUATION CONTRIBUTIONS	1		370.51
INV SUPER	19/07/2022	AUSTRALIAN CATHOLIC SUPERANNUATION RETIREMENT FUND	SUPERANNUATION CONTRIBUTIONS	1	370.51	
DD18138.1	25/07/2022	AWARE SUPER	SUPERANNUATION CONTRIBUTIONS	1		385.49
INV SUPER	02/08/2022	AWARE SUPER	SUPERANNUATION CONTRIBUTIONS	1	385.49	
DD18065.10	05/07/2022	QSUPER	SUPERANNUATION CONTRIBUTIONS	1		225.25
INV SUPER	05/07/2022	QSUPER	SUPERANNUATION CONTRIBUTIONS	1	225.25	
DD18065.11	05/07/2022	MEDIA SUPER	PAYROLL DEDUCTIONS	1		1,194.90
INV SUPER	05/07/2022	MEDIA SUPER	SUPERANNUATION CONTRIBUTIONS	1	876.26	
INV DEDUC	05/07/2022	MEDIA SUPER	PAYROLL DEDUCTIONS	1	318.64	
DD18065.12	05/07/2022	AUSTRALIAN SUPER PTY LTD	PAYROLL DEDUCTIONS	1		2,763.65
INV SUPER	05/07/2022	AUSTRALIAN SUPER PTY LTD	SUPERANNUATION CONTRIBUTIONS	1	2,606.34	
INV DEDUC	05/07/2022	AUSTRALIAN SUPER PTY LTD	PAYROLL DEDUCTIONS	1	139.78	
INV DEDUC	05/07/2022	AUSTRALIAN SUPER PTY LTD	PAYROLL DEDUCTIONS	1	17.53	
DD18065.13	05/07/2022	ANZ SMART CHOICE SUPER (ONEPATH MASTERFUND)	SUPERANNUATION CONTRIBUTIONS	1		263.22
INV SUPER	05/07/2022	ANZ SMART CHOICE SUPER (ONEPATH MASTERFUND)	SUPERANNUATION CONTRIBUTIONS	1	263.22	
DD18065.14	05/07/2022	AUSTRALIAN RETIREMENT TRUST	SUPERANNUATION CONTRIBUTIONS	1		153.01
INV SUPER	05/07/2022	AUSTRALIAN RETIREMENT TRUST	SUPERANNUATION CONTRIBUTIONS	1	153.01	
DD18065.15	05/07/2022	YKC SUPERFUND	PAYROLL DEDUCTIONS	1		865.39
INV SUPER	05/07/2022	YKC SUPERFUND	SUPERANNUATION CONTRIBUTIONS	1	634.62	
INV DEDUC	05/07/2022	YKC SUPERFUND	PAYROLL DEDUCTIONS	1	230.77	
DD18065.16	05/07/2022	MACQUARIE SUPER CONSOLIDATOR	SUPERANNUATION CONTRIBUTIONS	1		196.79

Ordinary Council Meeting Minutes  
17 August 2022



Date: 01/08/2022  
Time: 9:17:37AM

Shire of Northam

USER: Louise Harris  
PAGE: 65 13

Cheque /EFT No	Date	Name	Invoice Description	Bank Code	INV Amount	Amount
INV SUPER 05/07/2022		MACQUARIE SUPER CONSOLIDATOR	SUPERANNUATION CONTRIBUTIONS	1	196.79	
DD18065.17 05/07/2022		ZURICH AUSTRALIA LIMITED	PAYROLL DEDUCTIONS	1		662.52
INV SUPER 05/07/2022		ZURICH AUSTRALIA LIMITED	SUPERANNUATION CONTRIBUTIONS	1	485.85	
INV DEDUC05/07/2022		ZURICH AUSTRALIA LIMITED	PAYROLL DEDUCTIONS	1	176.67	
DD18065.18 05/07/2022		REST INDUSTRY SUPER	SUPERANNUATION CONTRIBUTIONS	1		1,320.00
INV DEDUC05/07/2022		REST INDUSTRY SUPER	PAYROLL DEDUCTIONS	1	287.45	
INV SUPER 05/07/2022		REST INDUSTRY SUPER	SUPERANNUATION CONTRIBUTIONS	1	1,032.55	
DD18065.19 05/07/2022		PRIME SUPER	SUPERANNUATION CONTRIBUTIONS	1		527.06
INV DEDUC05/07/2022		PRIME SUPER	PAYROLL DEDUCTIONS	1	140.55	
INV SUPER 05/07/2022		PRIME SUPER	SUPERANNUATION CONTRIBUTIONS	1	386.51	
DD18065.20 05/07/2022		NETWEALTH SUPERANNUATION	SUPERANNUATION CONTRIBUTIONS	1		312.62
INV SUPER 05/07/2022		NETWEALTH SUPERANNUATION	SUPERANNUATION CONTRIBUTIONS	1	312.62	
DD18065.21 05/07/2022		HOSIPLUS SUPER	SUPERANNUATION CONTRIBUTIONS	1		564.64
INV DEDUC05/07/2022		HOSIPLUS SUPER	PAYROLL DEDUCTIONS	1	50.00	
INV SUPER 05/07/2022		HOSIPLUS SUPER	SUPERANNUATION CONTRIBUTIONS	1	514.64	
DD18065.22 05/07/2022		SUNSUPER	SUPERANNUATION CONTRIBUTIONS	1		235.08
INV SUPER 05/07/2022		SUNSUPER	SUPERANNUATION CONTRIBUTIONS	1	235.08	
DD18065.23 05/07/2022		AMP LIFE LIMITED	SUPERANNUATION CONTRIBUTIONS	1		230.55
INV SUPER 05/07/2022		AMP LIFE LIMITED	SUPERANNUATION CONTRIBUTIONS	1	230.55	
DD18124.10 19/07/2022		QSUPER	SUPERANNUATION CONTRIBUTIONS	1		234.07
INV SUPER 19/07/2022		QSUPER	SUPERANNUATION CONTRIBUTIONS	1	234.07	
DD18124.11 19/07/2022		MEDIA SUPER	PAYROLL DEDUCTIONS	1		1,194.90

Ordinary Council Meeting Minutes  
17 August 2022



Date: 01/08/2022  
Time: 9:17:37AM

Shire of Northam

USER: Louise Harris  
PAGE: 66 10

Cheque /EFT No	Date	Name	Invoice Description	Bank Code	INV Amount	Amount
INV SUPER	19/07/2022	MEDIA SUPER	SUPERANNUATION CONTRIBUTIONS	1	876.26	
INV DEDUC	19/07/2022	MEDIA SUPER	PAYROLL DEDUCTIONS	1	318.64	
DD18124.12	19/07/2022	AUSTRALIAN SUPER PTY LTD	PAYROLL DEDUCTIONS	1		4,977.35
INV SUPER	19/07/2022	AUSTRALIAN SUPER PTY LTD	SUPERANNUATION CONTRIBUTIONS	1	4,504.79	
INV DEDUC	19/07/2022	AUSTRALIAN SUPER PTY LTD	PAYROLL DEDUCTIONS	1	367.38	
INV DEDUC	19/07/2022	AUSTRALIAN SUPER PTY LTD	PAYROLL DEDUCTIONS	1	105.18	
DD18124.13	19/07/2022	ANZ SMART CHOICE SUPER (ONEPATH MASTERFUND)	SUPERANNUATION CONTRIBUTIONS	1		267.18
INV SUPER	19/07/2022	ANZ SMART CHOICE SUPER (ONEPATH MASTERFUND)	SUPERANNUATION CONTRIBUTIONS	1	267.18	
DD18124.14	19/07/2022	AUSTRALIAN RETIREMENT TRUST	SUPERANNUATION CONTRIBUTIONS	1		207.88
INV SUPER	19/07/2022	AUSTRALIAN RETIREMENT TRUST	SUPERANNUATION CONTRIBUTIONS	1	207.88	
DD18124.15	19/07/2022	YKC SUPERFUND	PAYROLL DEDUCTIONS	1		865.39
INV SUPER	19/07/2022	YKC SUPERFUND	SUPERANNUATION CONTRIBUTIONS	1	634.62	
INV DEDUC	19/07/2022	YKC SUPERFUND	PAYROLL DEDUCTIONS	1	230.77	
DD18124.16	19/07/2022	MACQUARIE SUPER CONSOLIDATOR	SUPERANNUATION CONTRIBUTIONS	1		253.50
INV SUPER	19/07/2022	MACQUARIE SUPER CONSOLIDATOR	SUPERANNUATION CONTRIBUTIONS	1	253.50	
DD18124.17	19/07/2022	ZURICH AUSTRALIA LIMITED	PAYROLL DEDUCTIONS	1		724.19
INV SUPER	19/07/2022	ZURICH AUSTRALIA LIMITED	SUPERANNUATION CONTRIBUTIONS	1	531.07	
INV DEDUC	19/07/2022	ZURICH AUSTRALIA LIMITED	PAYROLL DEDUCTIONS	1	193.12	
DD18124.18	19/07/2022	REST INDUSTRY SUPER	SUPERANNUATION CONTRIBUTIONS	1		1,360.79
INV DEDUC	19/07/2022	REST INDUSTRY SUPER	PAYROLL DEDUCTIONS	1	298.33	
INV SUPER	19/07/2022	REST INDUSTRY SUPER	SUPERANNUATION CONTRIBUTIONS	1	1,062.46	

Date: 01/08/2022  
Time: 9:17:37AM

Shire of Northam

USER: Louise Harris  
PAGE: 67 13

Cheque /EFT No	Date	Name	Invoice Description	Bank Code	INV Amount	Amount
DD18124.19	19/07/2022	PRIME SUPER	SUPERANNUATION CONTRIBUTIONS	1		543.26
INV DEDUC	19/07/2022	PRIME SUPER	PAYROLL DEDUCTIONS	1	144.87	
INV SUPER	19/07/2022	PRIME SUPER	SUPERANNUATION CONTRIBUTIONS	1	398.39	
DD18124.20	19/07/2022	NETWEALTH SUPERANNUATION	SUPERANNUATION CONTRIBUTIONS	1		312.62
INV SUPER	19/07/2022	NETWEALTH SUPERANNUATION	SUPERANNUATION CONTRIBUTIONS	1	312.62	
DD18124.21	19/07/2022	HOSTPLUS SUPER	SUPERANNUATION CONTRIBUTIONS	1		571.57
INV DEDUC	19/07/2022	HOSTPLUS SUPER	PAYROLL DEDUCTIONS	1	50.00	
INV SUPER	19/07/2022	HOSTPLUS SUPER	SUPERANNUATION CONTRIBUTIONS	1	521.57	
DD18124.22	19/07/2022	SUNSUPER	SUPERANNUATION CONTRIBUTIONS	1		214.97
INV SUPER	19/07/2022	SUNSUPER	SUPERANNUATION CONTRIBUTIONS	1	214.97	
DD18124.23	19/07/2022	AMP LIFE LIMITED	SUPERANNUATION CONTRIBUTIONS	1		230.15
INV SUPER	19/07/2022	AMP LIFE LIMITED	SUPERANNUATION CONTRIBUTIONS	1	230.15	

REPORT TOTALS

Bank Code	Bank Name	TOTAL
1	MUNIFUND	2,049,564.92
TOTAL		2,049,564.92

## Attachment 2: Declaration

### Payment dates 1<sup>st</sup> July 2022 – 31<sup>st</sup> July 2022

- Municipal Fund payment cheque numbers 35509 to 35515 Total \$35,158.28.

#### Electronic Funds Transfer

- Municipal Fund EFT44134 to EFT44460 Total \$1,922,165.42.
- Direct Debits Total \$92,241.22.

All have been made in accordance with delegated authority reference number (M/F/F/Regs LGA 1995 S5.42).

Month	Cheques 2022/2023	EFT Payments 2022/2023	Direct Debits 2022/2023	Payroll 2022/2023	Total Payments 2022/2023
July	\$ 35,158.28	\$ 1,922,165.42	\$ 92,241.22	\$ 450,983.16	\$ 2,500,548.08
August					\$ -
September					\$ -
October					\$ -
November					\$ -
December					\$ -
January					\$ -
February					\$ -
March					\$ -
April					\$ -
May					\$ -
June					\$ -
<b>Total</b>	<b>\$ 35,158.28</b>	<b>\$ 1,922,165.42</b>	<b>\$ 92,241.22</b>	<b>\$ 450,983.16</b>	<b>\$ 2,500,548.08</b>

The following table presents all payments made for the month from Council credit cards paid by direct debit DD18090.1 - \$5,290.52

Summary Credit Card Payments	\$	Total
<b>CEO</b>		
PERSONAL PURCHASE - REFUNDED NEXT MONTH	500.00	
DOMINOS NORTHAM - CATERING FOR COUNCIL MEETING	175.50	
		<b>\$ 675.50</b>

<b>Executive Manager of Community Services</b>	
SQUARESPACE INC - BKB WEBSITE ANNUAL SUBSCRIPTION	300.00
HARVEY NORTHAM - CRICUT CUTTING MACHINE AND TOOLS	468.00
COLES - BKB NATIONAL RECONCILIATION	149.26
CRIME CHECK AUSTRALIA - DONNA MOODY CLEARANCE	99.00
CRIME CHECK AUSTRALIA - JULIE WYNNE CLEARANCE	99.00
FACEBOOK - JOB AD- BKB MANAGER	539.53
BETTA HOME AND LIVING NORTHAM - CREATE 298 KETTLE	109.00
DOMINOS NORTHAM - PIZZA REC CENTRE	122.00
DOMINOS NORTHAM - PIZZA REC CENTRE	96.85
DOME NORTHAM - JO & JASON COFFEE WITH SUPERINTENDENT	15.20
DOMINOS NORTHAM - PIZZA REC CENTRE	94.15
	<b>\$ 2,091.99</b>
<b>Executive Manager of Corporate Services</b>	
CPP CONVENTION CENTRE - FINANCIAL REPORT WORKSHOP (PARKING)	23.22
AMAYSIM MOBILE PTY LTD - LIBRARY LIFT PHONE DATA	10.00
ADOBE ID CREATIVE CLOUD - MONTHLY FEES	213.99
SOFTWARE MART AUS - WINDOWS LICENCE KEYS * 15	550.00
CLASSIC IT SUPPORT - SSD HARD DRIVES * 15	1125.00
CREDIT CARD FOREIGN TRANSACTION FEE	123.77
	<b>\$ 2,045.98</b>
<b>Executive Manager of Development Services</b>	
SOFTWARE MART AUS - WINDOWS 10 LICENCES KEYS X 5	200.00
CREDIT CARD - ANNUAL FEE	39.00
	<b>\$ 239.00</b>
<b>Executive Manager of Engineering Services</b>	
RLSSWA - POOL LIFE GAURD REQUALIFICATION - DAVID EMERY	159.00
	<b>\$ 159.00</b>
<b>Community Emergency Services Manager</b>	
HOME BAKE SHOP - TRAINING REFRESHMENTS	49.40



COLES - WELFARE FOR TRAINING NIGHT	29.65	
		\$ 79.05
<b>Total Credit Card Expenditure</b>		<b>\$ 5,290.52</b>

CERTIFICATION OF THE PRESIDENT

I hereby certify that this schedule of account covering vouchers and electronic fund transfer payments as per above and totalling \$2,500,548.08 was submitted to the Ordinary Meeting of Council on Wednesday, 17 August 2022.



CERTIFICATION OF THE PRESIDENT

CERTIFICATE OF THE CHIEF EXECUTIVE OFFICER

This schedule of accounts paid covering vouchers \$2,500,548.08 was submitted to each member of the Council on Wednesday, 17 August 2022, has been checked and is fully supported by vouchers and invoices which are submitted herewith, and which have been duly certified as to the receipt of goods and the rendition of services and as to prices, computations and casting and the amounts shown are due for payment.

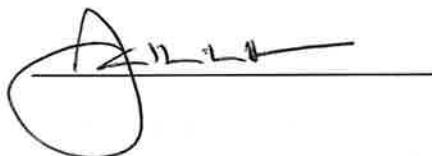

CHIEF EXECUTIVE OFFICER



## 13.5 COMMUNITY SERVICES

### 13.5.1 Nyoongar Cultural Advisory Group

<b>File Reference:</b>	2.1.3.8
<b>Reporting Officer:</b>	Cheryl Greenough, Manager Bilya Koort Boodja
<b>Responsible Officer:</b>	Jo Metcalf, Executive Manager Community Services
<b>Officer Declaration of Interest:</b>	Nil
<b>Voting Requirement:</b>	Simple Majority
<b>Press release to be issued:</b>	No

#### BRIEF

This report is for Council to consider the recommendations and actions from the Nyoongar Cultural Advisory Group (NCAG).

#### ATTACHMENTS

- Attachment 1: Diagram of some proposed changes.  
Attachment 2: notes from the meeting.

#### A. BACKGROUND / DETAILS

Council has had a Nyoongar Cultural Advisory Group Committee in place for some time. A report was provided to Council in July 2022 highlighting officer concern at the level of engagement from the committee. It is the officers view this disengagement has been influenced largely by the following factors

- Formal structure of the committee;
- Level of detail provided in committee agendas;
- Increased requirement for complying with standing orders and other local government frameworks, such as declarations of interest; and
- Inability for members to raise general business during the meeting.

Council resolved as follows at its July 2022 meeting

#### RECOMMENDATION #2

**That Council:**

- 1. Direct the Chief Executive Officer to establish a Nyoongar Cultural Advisory Group.**
- 2. Advisory Group membership to include a representative of the following families:**

- a. **Ryder**
  - b. **Garlett**
  - c. **Stack**
  - d. **Slater**
  - e. **McGuire**
  - f. **Kickett**
  - g. **Moody**
  - h. **Davis**
  - i. **Any other family groups as agreed by majority of the above-mentioned families**
3. **Matters to be discussed at the Group meetings to include**
    - a. **Bilya Koort Boodja operations**
    - b. **Matters raised by the Shire of Northam pertaining to aboriginal culture**
    - c. **Matters raised by working group**
  4. **Direct the Chief Executive Officer to provide a report to Full Council outlining discussions held at the working group meetings and making any recommendations to Council as deemed appropriate.**

The newly formed working group has now held its first meeting, the subject of this item is to report to Council the outcomes and items for discussion at the meeting.

## **B. CONSIDERATIONS**

### **B.1 Strategic Community / Corporate Business Plan**

Theme Area 1: Economic Growth.

Outcome 4.2: Northam honours, and is recognised for, its unique heritage and cultural identity.

Objectives:

There is a strong, respected and valued Aboriginal community and culture in the Shire of Northam

### **B.2 Financial / Resource Implications**

TBA – Possible costs for Elder attendance.

Possible costs for alterations to exhibition space.

### **B.3 Legislative Compliance**

Nil.

### **B.4 Policy Implications**

Nil.

### **B.5 Stakeholder Engagement / Consultation**

Advisory Group consultation.

### B.6 Risk Implications

Risk Category	Description	Rating (likelihood x consequence)	Mitigation Action
Financial	Without the Advisory Group and Elder input the BKB could suffer financially	Possible (3) x Medium (3) = Moderate (9)	Ensure continuity in working with the Elders and Advisory Group
Health & Safety	Nil		
Reputation			
Service Interruption	Nil		
Compliance			
Property			
Environment			

### B.7 Natural Environment Considerations

N/A.

## C. OFFICER'S COMMENT

The Advisory Group meetings are structured into three sections, which will form the structure of reporting to Council.

The following people were in attendance:

- Cr. Attila Mencshelyi – Councillor, Shire of Northam
- Jason Whiteaker – CEO, Shire of Northam
- Cheryl Greenough - BKB Centre Manager
- Jaime Hawkins – Community Development Officer, Shire of Northam
- Kathy Davis – Elder
- Liz Stack – Stack family representative
- Shirley Slater – Slater family representative
- Donna Moody – Moody family representative
- Brenda DeAtta – Other Nyoongar representative

Brenda DeAtta did an acknowledgement to country. It was agreed either a welcome or acknowledgment to country should be done at the start of each meeting.

Bilya Koort Boodja operations

- i. Welcome provided to Cheryl Greenough as the new Centre Manager. Cheryl provided a background on herself to the working group, including her heritage as a Koori woman. All family representatives extended a strong welcome to Cheryl.
- ii. Discussion around opening hours. It was agreed that it would be a positive outcome to have the centre hours of opening put back to 9am to 4pm, acknowledging the staff issues the Centre has experienced.
- iii. Cheryl provided an update on the renewal works which are being undertaken in the BKB exhibition space. The group decided to do a walk through with Cheryl to gain a better understanding of the upgrades and provide some input;
  - The text on the wall at the entry to “Welcome to Country” is too small and needs to be enlarged
  - The quote on the wall by Veronica McGuire is not to be changed.
  - The map on the wall as you exit Welcome to Country is too small and should be enlarged to show the entire Nyoongar Nation.
  - QR codes should be incorporated into the map table to allow more immersive interaction and to provide viewers with coordinates/directions to look at landmarks on country.
  - Allow a drone to take pictures to identify the landscapes shown on the map table and obtain Nyoongar names for the landscapes. Jermaine Davis from WNRM may already have suitable photos.
  - The suggested Wargyl trail on the map table should depict a serpent with bright colours.
  - More stories are to be collected from Ballardong people outside of the Northam area so the centre is more inclusive of all Ballardong.
  - Two of the season names are spelt in the Whadjuk spelling, can these be changed to the Ballardong spelling.
  - There will also be a pictorial display of a burning Balga tree.
- iv. There were discussions around the use of the meeting rooms. It was agreed that the meeting rooms should be made available to anyone, however there should be a condition for attendees to receive a welcome to country or be required to make an acknowledgement to country and also go through the BKB interpretive centre. The desire of the group was that anyone using the building should leave more culturally aware.

Matters raised by the Shire of Northam pertaining to aboriginal culture:

- i. It was discussed that more family names should be included in the Advisory Group with the possibility of proxies being included in the event one of the families cannot be represented on that day.

Valery and Rod Garlett were to be approached to attend as Kirk Garlett is often not available. Others families to be approached to attend are the Winmar family, Yvonne Kickett can represent the Winmar family and the Yarran family, Michelle or Karren.

- ii. Spoke about the challenge around getting elders and family representatives to attend meeting. There was a feeling that come members were having trouble attending due to work pressures. A suggestion was made that as some of the members work, the Shire may be able to speak to employers and advise how important this meeting is so they will allow the family member to attend.
- iii. Discussion around getting a list of people who can do welcome to country and didgeridoo playing etc. The group are to advise the names of people who can provide various services such as Welcome to Country and Didgeridoo playing to the BKB manager to ensure bookings can be fulfilled.
- iv. Discussion around the opportunity to share cultural sites with other members of the community. Once such site is the birthing site on Katrine Road. Was agreed that places such as the birthing site could be used as tourist opportunities however we needed to be careful with cultural sensitivities for example the Birthing Site is a place for women's business and as such men are not able to attend. This being the case it may be an opportunity to do organised tours of the site at regular interval under the guidance of a local female elder.
- v. Discussions were held about the Aboriginal Reserve and the CEO advised the Shire is working with the Aboriginal Lands Trust to resolve the issue. The attendees at the meeting indicated there desire to not have people staying at the site as it is currently a place which can not be accessed or shared by the entire community as it once was. There was support for the Shire to continue to work to address the issues currently being experienced.
- vi. Co-naming of sites. It was agreed this was a strong desire of the committee. The first name to be agreed was for the Avon River. More information will be provided to the next meeting where a name will be agreed and recommended to Council for adoption.

Matters raised by working group:

Payments for Elders attending Advisory Group meetings was an issue raised. It was agreed that this would be put on as a dot point item for the next meeting

(Latest update post meeting) The plan for the Lullabies project participants could perform as part of the Bilya Festival cannot go ahead as key facilitators are not available on that date however a display and some of their songs will be played on CD at the VIP function.

**RECOMMENDATION / COUNCIL DECISION**

**Minute No: C.4539**

**Moved: Cr Ryan**  
**Seconded: Cr Girak**

**That Council:**

- 1. Accept the report as presented.**
- 2. That the following families be approached to attend the meetings:**
  - **Garlett family.**
  - **Winmar family.**
  - **Yarran family.**

**CARRIED 10/0**

### Attachment 1

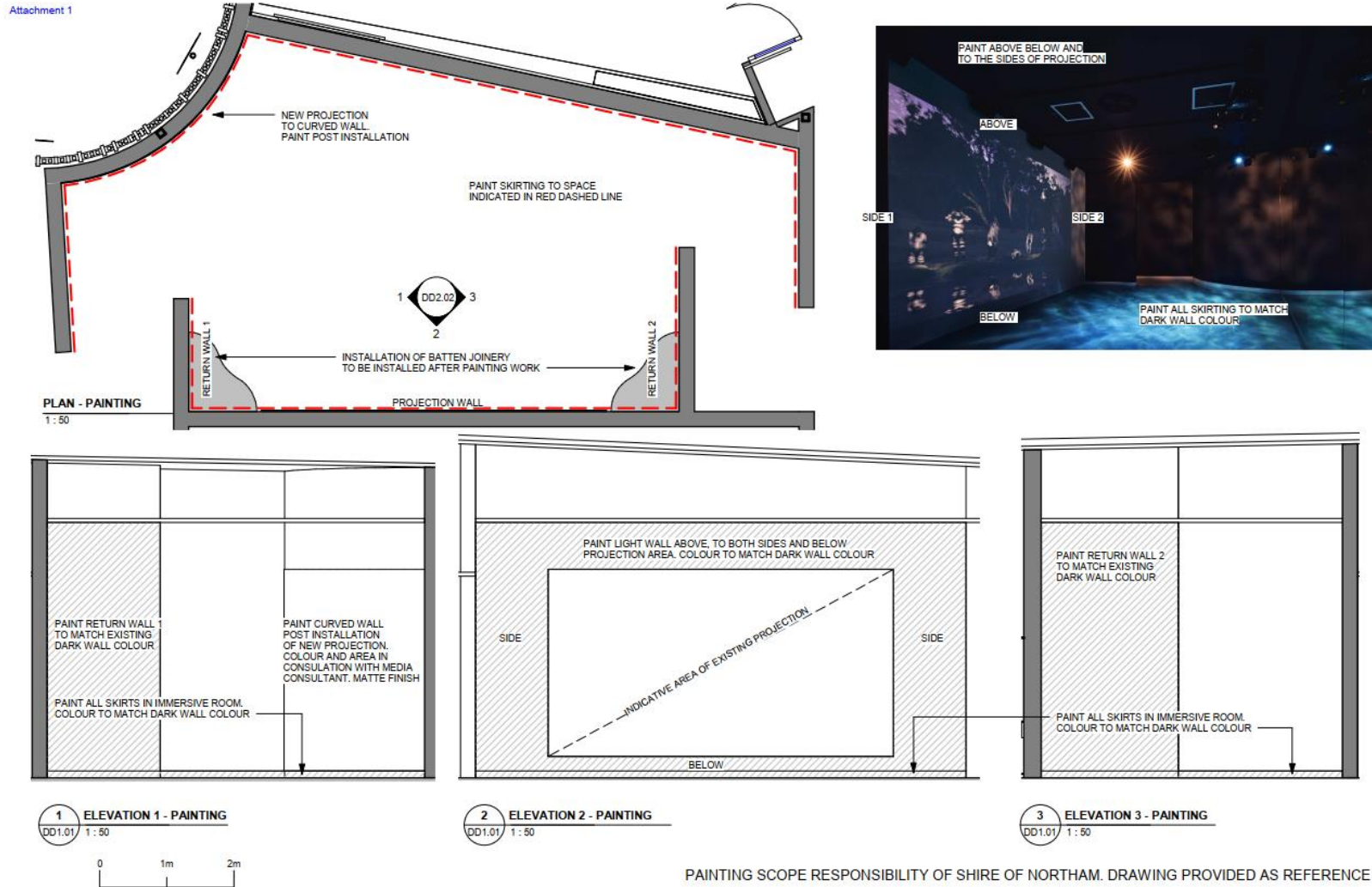

CANBERRA:  
16 Stephens Road  
Queanbeyan, 2620  
P: +61 2 6299 7340  
E: canb@thylacine.com.au

MELBOURNE:  
7/311 St. Place, 1 Trisovick St  
Brunswick VIC 3066  
P: +61 3 9427 9779  
E: melb@thylacine.com.au

REV	DATE	AMENDMENT
1	16/02/22	Information for painting

SHIRE OF NORTHAM  
BKB Stage 2  
D466

DRAWING NAME  
PAINTING Immersive Space

AUTHOR: CW  
CHECKED: CM

DRAWING NUMBER  
DD2.02 - 1

DATE: 16/02/22  
SCALE: 1:50





## Nyoongar Cultural Advisory Group Meeting 27 July 2022

### MINUTES

#### ATTENDANCE:

Cr. Attila Mencshelyi – Councillor, Shire of Northam  
Jason Whiteaker – CEO, Shire of Northam  
Cheryl Greenough - BKB Centre Manager  
Jaime Hawkins – Community Development Officer, Shire of Northam  
Kathy Davis – Elder  
Liz Stack – Stack family representative  
Shirley Slater – Slater family representative  
Donna Moody – Moody family representative  
Brenda De Atta – Other Nyoongar representative

#### Meeting Opened at 3:45pm

Committee update from CEO Jason Whiteaker:

- Council has disbanded the formal committee. This allows the meeting structure to be more informal. The outcomes of the advisory group meetings will still be reported to Council.

Brenda De Atta said an Acknowledgement to Country. This was initially missed. **ACTION:** Ensure that each meeting open with an Acknowledgement or Welcome to Country and 1 minutes silence for Sorry Time.

The Group observed 1 minutes silence for Sorry Time.



## Update on BKB

### Appointment of Centre Manager:

- New manager Cheryl Greenough introduced herself as a proud Koori woman from the New South Wales South Coast. She has been living in the Northam area for the past 30 years and has worked at the Shire in a governance role for the past 7 years. She is really excited to be learning about culture through the role.

### BKB opening hours:

- Kathy Davis requested the opening hours go back to being 9am – 4pm. The group agreed.
- Cheryl has been helping on weekends and will do as necessary.
- Kathy Davis said we need to work as a community to make this place work.
- **ACTION:** Kathy Davis is available to work Sundays and Liz Stack said she will be available for weekends in the summertime.

### Bilya Festival (Avon Descent):

- VIP function to be held at the BKB on 12 August. Cyndy Moody and the Northam Nyoongar Lullabies will be performing.
- A Welcome to Country will be performed at the start of the street parade.
- A large Wargal street puppet is being built and decorated by Kirk Garlett. Daniel Garlett will play the didgeridoo and his dancers will lead the Wargal which will meander through the street.
- A Blessing of the River will be performed before the race.
- **ACTION:** Jaime Hawkins to find out who is doing the Blessing of the River and inform Kathy Davis. **RESPONSE:** Daniel Garlett has been organised. Kathy informed.
- Kathy suggested that it should be Liz Stack or Shirley Slater. Liz Stack said Pat Davis should be asked first, as she was the Elder to start the tradition.

### Changes to the exhibition:

- Group agreed the text on the wall as you enter the exhibition is too small.
- The quote from Veronica McGuire cannot be changed.
- The map of Nyoongar Country is too small. The map should be enlarged and show the entire Nyoongar Nation.
- QR codes to be incorporated into the map table to allow more immersive interaction.
- Take drone pictures to identify the landscapes on the map table and obtain the Nyoongar names for them. **ACTION:** Talk to Jermaine Davis at Wheatbelt NRM, as they have photos and videos already collected.
- **ACTION:** The Wargal trail on the map table to be depicted as a serpent with bright colours.



- More stories are to be collected from Ballardong people outside of Northam, so the centre is more inclusive of all Ballardong.
- Liz Stack asked if the seasons could be changed as some of the panels contain Whadjuk spelling instead of Ballardong. **ACTION:** Cheryl to investigate.
- There is to be a representation of a burning balga stem. **ACTION:** Cheryl to clarify where this will be positioned.
- Shirley Slater shared how they would light the balga stem to make fire.

### Items for Council

Family representation on the NCAG:

- Winmar and Yarran families should be also represented. Yvonne Kickett can represent the Winmar family. **ACTION:** Karren and Michelle should be approached to represent the Yarran families.
- **ACTION:** Valerie and Rod Garlett to be approached to attend meetings. Kirk Garlett currently represents the Garlett family however, struggles to attend meetings and already contributes a lot to the community.
- Under the Committee of Council structure only one person could represent each family, under the new structure we can have more representatives.
- Donna Moody suggested that not everyone is able to get released from work to attend, so the Shire could speak to those employers to ask if they could release them for the meetings.

Who can perform Welcome to Country:

- Deborah Moody
- Pat Davis
- Liz Stack
- Shirley Slater

**ACTION:** Group to advise Cheryl if there are any others.

For the playing of the didgeridoo:

- Frank Davis
- Trevor Davis
- Daniel Garlett
- Phillip Walley Stack

Kathy Davis spoke of the Youth at Risk Group she started, she would like to see the boys taught how to make didgeridoos as well as play them. She encouraged the other group members to attend the youth at risk meetings.



#### Dual naming of the Avon River:

- **ACTION:** Liz Stack will inform Cheryl of the Ballardong name for the Avon River. It is in a book at Northam Primary School.
- Donna Moody has a story of her uncle that refers to the Nyoongar name for the Mortlock River as Ngaarin (unsure of spelling).

#### Birthing Site:

- **ACTION:** Kathy Davis requested female Shire workers conduct a clean-up of the birthing site. The weeds are overgrown. Wheatbelt NRM can provide a female ranger to accompany the Shire workers.
- Discussion about whether there is signage and if the site should be promoted. BKB can promote it and do tour groups for women, but not advertise its location as this might tempt men to go out there. There are also some men's sites behind Yongah Hill and Mt Ommaney.

#### General Discussion

- Discussion about the Aboriginal Reserve. Jason Whiteaker informed the group that the Shire is working with Aboriginal Lands Trust regarding the Reserve. It requires a whole of community approach, and he will keep the group updated on any developments.
- Shirley Slater inquired about the whereabouts of posters that were at the Visitors Centre of family trees of people that were at the Reserve. Jason Whiteaker said they were removed and put in storage out of respect after some families had issues with the information contained on them, saying it was wrong. **ACTION:** Locate the posters and bring them to the next meeting for the group to view.
- There should be conditions placed on the hire of meeting rooms for non-cultural purposes at the BKB that the hirer has to engage in some form of cultural awareness, such as a tour of the exhibition space, have Elder do a Welcome to Country etc.
- Group approve of Yolanda from Headspace attending the next meeting to yarn about having a mental health and having a professional working from the centre once a month.
- The Aboriginal Cultural Heritage Act 2021 (Dept Planning Lands and Heritage) meeting held at the BKB. They want to get Nyoongar people involved in the design of the Act. There will be another meeting held next month.
- **ACTION:** Meeting payments be included in the agenda for discussion at the next meeting.

**Meeting Closed at 5:15pm**

## 14. MATTERS BEHIND CLOSED DOORS

### RECOMMENDATION / COUNCIL DECISION

Minute No: C.4540

Moved: Cr Ryan  
Seconded: Cr Girak

That Council, in accordance with section 11.1(i) of the Shire of Northam Standing Orders Local Law 2018 and Section 5.23 (2) (b) (c) (d) of the Local Government Act 1995, meet behind closed doors to consider agenda items:

- 14.1 Lease of a portion of Reserve 44700 - as the matter relates to a contract which may be entered into.
- 14.2 Unauthorised Structure – A72 – as the matter relates to the personal affairs of a person and legal advice obtained or which may be obtained.

CARRIED 10/0





The Gallery left the meeting at 6:12pm.

### 14.1 LEASE OF A PORTION OF RESERVE 44700

#### PART 1

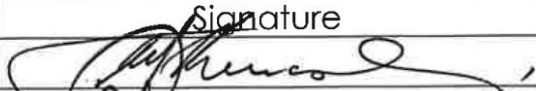
Councillors will be requested to indicate if they support a motion to revoke the decision made. This is to be inclusive of Cr Mencshelyi as the mover of C.4431.

Notice is hereby given by the following:

	Councillor Name	Signature
1.	Cr Attila Mencshelyi	
2.	Cr Michael Ryan	
3.	Cr Des Hughes	
4.	Cr Hayden Appleton	

Acting Governance Coordinator left the meeting at 6:12pm

To revoke or change the following decision

Meeting / Date	16 March 2022
Agenda Item No	14.4
Agenda Item Name	Lease of Lot 29081 Aphylla Road, Burlong
File Reference	A2380
Resolution No	C.4431

#### RECOMMENDATION / COUNCIL DECISION

**Minute No: C.4431**

**Moved: Cr Mencshelyi**

**Seconded: Cr Curtis**

**That Council authorise:**

- 1. Disposal of 21 ha of Lot 29081 Aphylla Road, Burlong by lease agreement for a period of three (3) years with a further option of two (2) years at the cost of \$2,016 per annum.**
- 2. The Lessee to maintain firebreaks and fences to the satisfaction of the Shire.**
- 3. Advertisement of the property in accordance with s3.58 of the Local Government Act 1995.**
- 4. The CEO and Shire President to affix the common seal to the lease agreement.**

**CARRIED 9/0**

#### PART 2

With the support of the required number of Councillors it is recommended that the decision made at the Ordinary Council Meeting on 16 March 2022 be revoked.

#### RECOMMENDATION / COUNCIL DECISION

**Minute No: C.4541**

**Moved: Cr Ryan**

**Seconded: Cr Hughes**

**That Council revoke decision C.4431 which was made at the Ordinary Council Meeting held on 16 March 2022.**

**CARRIED 10/0**

Acting Governance Coordinator returned to the meeting at 6:14pm.

PART 3

Councillors will be invited to move an alternative motion for the disposal of a portion of Reserve 44700.

**RECOMMENDATION / COUNCIL DECISION**

**Minute No: C.4542**

**Moved: Cr Ryan**

**Seconded: Cr Mencshelyi**

**That Council:**

1. In accordance with section 3.58 of the *Local Government Act 1995*, give local public notice of the proposed disposal of a portion of Reserve 44700 comprising of 41.8 hectares (as highlighted on Attachment 1) to Mr David Painter and Mrs Elissa Painter for a period of three (3) years with a renewal option of two (2) years at the cost of \$2,016 per annum.
2. Declares that the valuation which was carried out more than 6 months before the proposed disposition is believed to be a true indication of the value at the time of the proposed disposal.
3. Subject to there being no objections to the proposed disposal, dispose of a portion of Reserve 44700 comprising of 41.8 hectares (as highlighted on Attachment 1) to Mr David Painter and Mrs Elissa Painter for a period of three (3) years with a renewal option of two (2) years at the cost of \$2,016 per annum, in accordance with section 5.0 of Council Policy A 8.5 Management of Council Property Leases and subject to:
  - a. Section 18 approval under the *Land Administration Act 1997* being provided by the Minister for Planning, Lands and Heritage.

**CARRIED 10/0**

*Cr J E G Williams declared a "Proximity" interest in item 14.2 – Unauthorised Structure – A72 as a property that Cr Williams co-owns is located directly across a thoroughfare from the subject property.*

*Cr J E G Williams left the meeting at 6:15pm.*

## **14.2 UNAUTHORISED STRUCTURE – A72**

### **RECOMMENDATION / COUNCIL DECISION**

**Minute No: C.4543**

**Moved: Cr Mencshelyi**

**Seconded: Cr Galloway**

**That Council authorise the CEO to:**

- 1. Correspond with the owner of 4 Hovea Crescent, Wundowie requesting removal of the structure and of Council's intent to initiate legal proceedings under section 214 of the Planning and Development Act 2005 should the owner fail to comply.**
- 2. Initiate legal action under the provisions of section 214 of the Planning and Development Act 2005 for unauthorised development should the building not be removed or a satisfactory response is not received within 21 days.**

**CARRIED 9/0**

### **RECOMMENDATION / COUNCIL DECISION**

**Minute No: C.4544**

**Moved: Cr Ryan**

**Seconded: Cr Appleton**

**That Council move out from behind closed doors.**

**CARRIED 9/0**

Cr Williams returned to the meeting at 6:17pm.

The Gallery returned to the meeting at 6:17pm.



## 15. MOTIONS OF WHICH PREVIOUS NOTICE HAS BEEN GIVEN

### 15.1 FENCED DOG PARK

#### MOTION / COUNCIL DECISION

Minute No: C.4545

Moved: Cr Antonio

Seconded: Cr Girak

That Council request the Chief Executive Officer to investigate the various options and associated costs of establishing a fenced area for a dog park based on the request from ratepayers and report back to Council.

**CARRIED 10/0**

Calm Canines  
61 Wood Drive, Northam  
WA 6401  
M: 0434 078 533  
E: [ktr1965eagle@hotmail.com](mailto:ktr1965eagle@hotmail.com)

9<sup>th</sup> June 2022

Shire of Northam  
395 Fitzgerald St, Northam  
WA 6401

### **Re Fenced Dog Exercise Area in Northam**

To whom it may concern,

I am writing in support of a fully fenced dog exercise area within the Shire of Northam. Off-leash dog parks such as Bert Hawke Oval have many benefits for dogs and their owners. They provide the opportunity for dogs to exercise, socialise with other dogs, enjoy the fresh air, practice training techniques, play games and generally race around and burn off energy.

These activities are important for physical health because they prevent problems such as obesity and joint disfunction. They also provide essential mental stimulation and prevent the development of problem behaviours such as destructiveness or excessive barking.

For owners, it's fun to meet other owners, swap tips and even make new friends.

Despite their growing popularity, off-leash dog parks are not however suitable for all dogs. To ensure that owners, their dogs and others can safely enjoy the experience of an off-leash park, there are several important considerations to keep in mind.

Off-leash parks are public areas that are not supervised by trained staff in a controlled environment. There is no screening process to determine which dogs (or owners) may visit. This means the safety of both people and dogs depends on owners being responsible and adhering to good dog park etiquette.

It is highly inadvisable to take a dog to an off-leash park until they have undergone basic training, such as the training offered at puppy preschools, followed by more advanced training. Owners need to be confident that their dog will reliably come to them when called (the 'recall' command). If owners feel unable to keep their dog under control, he or she is not ready for an off-leash park. As an alternative, dogs may benefit from a fenced off area with small, medium and large areas within an off-leash park where they can safely run off leash.

Owners also need to be confident that their dog will relate to other dogs without becoming fearful or aggressive. Dog parks such as Bert Hawke Oval or Henry Street Oval are highly arousing to all dogs due to the physical environment and the presence of other dogs. The stimulation of sudden contact with unfamiliar dogs of varying breeds, sizes and temperaments can be overwhelming for nervous dogs, especially where there is no easy escape from the situation. Dogs have four options available to them flight, fight, freeze or submit. Being on leash reduces their options and often exacerbates the problem. Being off leash increases the owners anxiety which the dog mirrors.

If the dog has not learned to socialise with other dogs, the interactions in an off-leash park, such as being approached by a group, or exposed to rough and tumble play,

mounting, sniffing, chasing and barking, can be perceived as threats rather than sources of enjoyment. Unknown humans approaching can also be over stimulating. Another risk is that the dog may fail to read warning cues from other dogs to 'back off', which can lead to being bitten. A negative experience in an off-leash park has the potential to reinforce behaviour problems, especially for dogs who are not well socialised or have had traumatic experiences.

For these reasons, I support a fully fenced dog exercise area with double gates and a small, medium and large dog area. This way, dogs can have a slow and gentle initial meeting with others through double gates and the opportunity to interact with dogs of a similar size as opposed to a free for all.

Signage would be beneficial asking owners not to enter if their dog is:

- Unvaccinated
- Not wormed
- Unwell
- Not Desexed

It is important owners collect their dogs waste to prevent spread of disease. It is also important to include adequate shade and water to reduce risk of heat stroke, particularly to flat faced breeds. I would also encourage seating areas for owners, so they can relax and demonstrate calm energy as dogs mirror our energy.

Although I couldn't find any current regulation of off-leash dog parks, The Dog and Cat Management Board of South Australia has developed a resource to assist local governments to design and manage these effectively and safely. This resource has suggestions for good planning that may assist you in your choice of fenced off-leash area, including: the provision of different activity zones (to allow both high running areas and quieter areas for one-on-one play between dogs or interactions with owners), secure fencing, multiple entry and exit points to prevent dogs converging at once, adequate water and shade, signage with rules for owners to observe, and dog equipment for enrichment and practising natural skills (such as tyres, tunnels, jumps).

(1) Government of South Australia. Dog and Cat Management Board (2013).

<https://cdn.dogandcatboard.com.au/dcmb/docs/Dogs/UnleashedDogParks-B.pdf>

I have trained over 280 dogs in the Wheatbelt to date. By far, the leading trend with dogs exhibiting unwanted behaviour has been a lack of socialisation with people and/or dogs and or lack of physical and/or mental stimulation (particularly working breeds like Kelpies.)

The main reasons people report the absence of these activities, is having no confidence in recall and a fear of other dogs approaching without careful introduction first. And sadly, being time poor to walk around the streets.

Unlike many other trainers I do not offer "lessons" in the park to my clients. Teaching a dog tricks such as jumping through hoops or shaking hands is of little benefit in my opinion. This approach will not stop the dog from barking at home for instance. I am a Behaviorist first and foremost and help owners get the bottom of WHY their dog is exhibiting unwanted behaviors. Very often this has to do with the role the dog is playing and once the owner can communicate to the dog that they can switch off and relax everything changes.

It is helpful though when a dog exhibits fear aggression to people and/or dogs or is timid to the point of stress, to take them NEAR a fenced dog area. Not into, but nearby where the dog can desensitise at a comfortable distance without unsolicited interaction. The owner can then slowly work on reducing reactivity, finish on a high and quit whilst their ahead. Eventually the dog can enter and interact. This has been the case in Merredin and York where fenced off areas have been established.

I hope that this proposal will be considered and am happy to be contacted any time.

Tanya Richardson  
Dog Trainer & Behaviorist



## Calm Canines

Helping dogs and their humans communicate





Tracy Saurin  
A1 Wheatbelt Dog Rescue  
[A1wheatbeltdogrescue@hotmail.com](mailto:A1wheatbeltdogrescue@hotmail.com)  
0408 857 854

Shire of Northam  
425 Fitzgerald St Northam, WA 6401

16<sup>th</sup> June 2022

To Whom it may concern,  
My name is Tracy Saurin and I run A1 Wheatbelt Dog Rescue.  
I am writing this letter in support of the proposed fenced dog exercise area in Northam.  
I believe that having an off-leash dog park would be hugely beneficial for dogs and their owners. To go to a designated area for a dog to run and play in a secure area would be a great advantage in Northam. To have a few sections would be the best way to go so dogs can have a secure way of having a meet & greet before going into the main are for a play with another dog.  
Thank your consideration and time in considering this proposal.

Yours sincerely,

**TSaurin**



**Wheatbelt Health Network Northam**  
ABN: 73 639 952 959  
25 Holtfreter Ave, Northam  
WA 6401  
T: 9621 4444  
F: 9621 4475  
E: [northam@wheatbelt.com.au](mailto:northam@wheatbelt.com.au)  
W: [www.wheatbelt.com.au](http://www.wheatbelt.com.au)

29th June 2022

The Shire of Northam  
PO Box 613  
NORTHAM WA 6401

Ms Terrie WEATHERBY (430968514)  
Unit2/27 Kennedy Street  
Northam  
WA Australia 6401  
[virginia.bell@nhcare.com.au](mailto:virginia.bell@nhcare.com.au)

I am wheelchair bound for mobility, and have a small dog . I would welcome a safe exercise area for my dog to exercise and we both socialise and mingle with other dogs and their owners. I am unable to safely walk my dog outside my unit as a neighbours dog barks through the fence and is intimidating to my small dog.

Yours sincerely



Terrie Weatherby



**Wheatbelt Health Network Northam**  
ABN: 73 639 952 959  
25 Holtfreter Ave, Northam  
WA 6401  
T: 9621 4444  
F: 9621 4475  
E: [northam@wheatbelt.com.au](mailto:northam@wheatbelt.com.au)  
W: [www.wheatbelt.com.au](http://www.wheatbelt.com.au)

6th July 2022

Shire of Northam.

Mrs Jennifer "Jen" STEDMAN (430367673)  
PO Box 1034  
Northam  
WA Australia 6401  
[stedmanjenn@hotmail.com](mailto:stedmanjenn@hotmail.com)

I have my name down to get an assistance dog , and being visually impaired I would appreciate a safe place to bring my dog to socialise and for my safe social interaction also.

Kind regards



Jennifer Stedman

Correct as at 3.31pm 5/7/2022

Assumptions \*\*

\*\* many Australian listed suburbs/postcodes correlate to where the petitioners computer is registered, not where they live

281 Australian signatures

\*\* no duplicates found

\*\* international signatures are signed from internationals

Name	City	Postal Code	Country	Signed On
Tanya Richardson	Northam	6401	Australia	30/05/2022
Keith Richardson	Northam	6000	Australia	30/05/2022
Kaitlyn George	Northam	6401	Australia	30/05/2022
Jamie Har	Perth	6000	Australia	30/05/2022
Justine Clune	Dalwallinu	6000	Australia	30/05/2022
Kim Bassett	Mirrabooka	6061	Australia	30/05/2022
Kerryn Franklin	Northam	6001	Australia	30/05/2022
Kymerlee Natkanski	Perth	6401	Australia	30/05/2022
Tim Natkanski	Northam	6401	Australia	30/05/2022
Shane Sibley	Northam	6401	Australia	30/05/2022
Stephanie Talay	Northam	6407	Australia	30/05/2022
Denise Nicholson	Northam	3363	Australia	30/05/2022
Jenny Lucy	NORTHAM	6401	Australia	30/05/2022
Ann Gibbs	Northam	6401	Australia	30/05/2022
Danni Bradfield	NORTHAM	6401	Australia	30/05/2022
Clare Stephens	Northam	6155	Australia	30/05/2022
Jodie Longmire	Northam	6401	Australia	30/05/2022
lucy McManus	northam	6401	Australia	30/05/2022
Stacie aiken	Clackline	6564	Australia	30/05/2022
Esther Bliss	Northam	6401	Australia	30/05/2022
Wendy Reid	Northam	6401	Australia	30/05/2022
Jo Stephen	Northam	6401	Australia	30/05/2022
Deborah Mcquienn	Perth	6208	Australia	30/05/2022



Kate Hayward-Waller	Northam	6401	Australia	30/05/2022
Rebecca Mulholland	Grass Valley	6105	Australia	30/05/2022
Nathan Hooper	Perth	6000	Australia	30/05/2022
Tracey Gunson	Perth	6060	Australia	30/05/2022
Jean Finnigan	Northam	6000	Australia	30/05/2022
Hayley Hayes		6401	Australia	30/05/2022
Virgil Hinsley	Northam	6401	Australia	30/05/2022
Tina McLean	Northam	6317	Australia	30/05/2022
Ms. Raelene Harris	Northam	6401	Australia	30/05/2022
Melanie Jones	Perth	6000	Australia	30/05/2022
Gwen Mills	Perth	6000	Australia	30/05/2022
Catherine Rostron	Cunderdin	6407	Australia	30/05/2022
Mackenzie Sargeant	Perth	6000	Australia	30/05/2022
Dearnna Byfield	Northam	6401	Australia	30/05/2022
Lisa Hasson	Northam	6401	Australia	30/05/2022
Pam Prater	Northam	6401	Australia	30/05/2022
Kylie Allan	Perth	6000	Australia	30/05/2022
Melissa Wilmott	Perth	6000	Australia	30/05/2022
Marcia Bignell		6401	Australia	30/05/2022
Jeneille Sinclair		6562	Australia	30/05/2022
Johnny MEADS	Bakers Hill	6562	Australia	30/05/2022
Paula Whittington	Northam	6401	Australia	30/05/2022
Billy Meade	Perth	6000	Australia	30/05/2022
Sandra Buttersfield	Northam	6401	Australia	30/05/2022
Shelley Disney	Northam WA	6401	Australia	30/05/2022
Michelle O'Driscoll	Perth	6401	Australia	30/05/2022
Karen Carter	Northam	6401	Australia	30/05/2022
Shelley McLean	Southern Brook	6401	Australia	30/05/2022
Sandra Wood	Perth	6151	Australia	30/05/2022
Rebecca Potocznyj	Northam	6401	Australia	30/05/2022
Clare Arthur	Northam	6401	Australia	30/05/2022
Tina Gunter	Melbourne	3011	Australia	30/05/2022
Aaron Laird	Perth	6148	Australia	30/05/2022

Bernie Swindells	Northam	6401	Australia	30/05/2022
Sue Rodgers	Northam	6401	Australia	30/05/2022
Maria Spark	Northam	6401	Australia	30/05/2022
Jennifer Thompson	Northam	6401	Australia	30/05/2022
Sarah Smith	Northam	6401	Australia	30/05/2022
Clare McAlaney		3195	Australia	30/05/2022
Emily Allan	Northam	6401	Australia	30/05/2022
Amber Balfour-Cunningham	Perth	6000	Australia	30/05/2022
Pip Corteen	Perth	6000	Australia	30/05/2022
Grace Heffernan	Perth	6000	Australia	30/05/2022
Debbie Hughes	Northam	6401	Australia	30/05/2022
Daniel McDonald	Perth	6000	Australia	30/05/2022
Sophia Gobby	Northam	6401	Australia	30/05/2022
Tiffany-Kate DeMarchi	Perth	6000	Australia	30/05/2022
Janine Bell	Northam	6401	Australia	30/05/2022
Hazel King	Perth	6000	Australia	30/05/2022
Patrick Eid	Illawong	2234	Australia	30/05/2022
magdalena niedzielska	Sydney	2000	Australia	30/05/2022
Matthew Kelly	Millendon	6056	Australia	30/05/2022
Paula Cranny	Perth	6000	Australia	30/05/2022
Nadine Clark	Perth	6000	Australia	30/05/2022
Tanya EVANS	WA	6753	Australia	30/05/2022
Jess Smith	Carlton	3053	Australia	30/05/2022
Amanda Abbott	Perth	6401	Australia	30/05/2022
Krischne Swanton	Perth	6000	Australia	31/05/2022
Georgina Critchlow	York	6302	Australia	31/05/2022
Brooke Kujundzic	Perth	6000	Australia	31/05/2022
Patricia Rumjantsev	Bakers Hill	6562	Australia	31/05/2022
Beth Carpenter	Northam	6401	Australia	31/05/2022
Toni Korotschuk-Rose	Northam	6401	Australia	31/05/2022
Marilyn de Beaux	Northam	6401	Australia	31/05/2022
Helen Singh	Perth	6401	Australia	31/05/2022
Stolp Abigail	Northam	6401	Australia	31/05/2022

Emily Purcell	Clackline	6564	Australia	31/05/2022
Katy Harman	Northam	6401	Australia	31/05/2022
Tracy Knappett	Spencers Brook	6000	Australia	31/05/2022
Lois Harman	Perth	6000	Australia	31/05/2022
Annabelle Marlow	Melbourne	3000	Australia	31/05/2022
Joanne Campione	Tweed Heads	2485	Australia	31/05/2022
Kath Boyle	Northam	6401	Australia	31/05/2022
James Fallows	Leschenault	6233	Australia	31/05/2022
Michael Rice	Northam	6401	Australia	31/05/2022
Jill Rice	Northam	6401	Australia	31/05/2022
Andrea Haigh	Northam	6401	Australia	31/05/2022
Thomas Hayes	Northam	6401	Australia	31/05/2022
Tracey Burges	Wundowie	6560	Australia	31/05/2022
Belinda Shaw	Northam	6401	Australia	31/05/2022
Jilly Wegner	Northam	6405	Australia	31/05/2022
Tiffany Cramer	Perth	6000	Australia	31/05/2022
Charissa Harvey	Northam	6401	Australia	31/05/2022
Maree Moore	Perth	6401	Australia	31/05/2022
Steven Brown	Perth	6000	Australia	31/05/2022
Cityrailsaints --	Sydney	2190	Australia	1/06/2022
Rose-Maree Ezeh	Northam	6401	Australia	1/06/2022
Claire Harloe	Karrinyup	6018	Australia	1/06/2022
Azfar Raza	Sydney	2000	Australia	2/06/2022
Joanne Buckley	Gold Coast	4221	Australia	2/06/2022
Lynn Travis	Clackline	6564	Australia	2/06/2022
Tjana Schmidt	Brisbane	4000	Australia	3/06/2022
Suzanne Roper	Northam	6401	Australia	3/06/2022
Anita Hodak	Brisbane	4068	Australia	3/06/2022
Potter Taylor	Northam	6401	Australia	3/06/2022
Mel Rowling	Northam	6401	Australia	3/06/2022
John Reynolds	Sydney	2076	Australia	3/06/2022
Saviz Kohistani	Perth	6000	Australia	4/06/2022
Ronnie Steele	Northam	6401	Australia	4/06/2022

Roma West	Perth	6000	Australia	4/06/2022
Debbie Barrett	Perth	6401	Australia	5/06/2022
Jodie Byers	Northam	6401	Australia	5/06/2022
Katina Baker		2229	Australia	5/06/2022
Harlequin Goodes	traralgon	3844	Australia	5/06/2022
Rebecca Gordon	Northam	6401	Australia	5/06/2022
Steve Lipple	Ringwood	3134	Australia	5/06/2022
Natalie Opitz	Port Macquarie	2444	Australia	6/06/2022
Pam Scamardella	Ravenshoe	4888	Australia	6/06/2022
Finn Brown	Melbourne	3000	Australia	6/06/2022
G Bradbury	Northam	6053	Australia	6/06/2022
Caroline Marriott	Perth	6000	Australia	6/06/2022
Julia Ryan	Northam	6401	Australia	6/06/2022
Alison Quin	Northam	6401	Australia	6/06/2022
Michaela O'DOHERTY	Toodyay	6566	Australia	6/06/2022
Davina Edwards	Perth	6000	Australia	6/06/2022
Genevieve Russ	Northam	6401	Australia	6/06/2022
Myra Hancock			Australia	6/06/2022
Leisha Watt	Northam	6401	Australia	6/06/2022
Cheyenne Bland	Beacon	6472	Australia	6/06/2022
Cara Meeres	Perth	6057	Australia	6/06/2022
Kate Swenson	Northam	6401	Australia	6/06/2022
John Cenna	Northam	6401	Australia	6/06/2022
Sandy Floyd	Northam	6401	Australia	6/06/2022
Josh Hartland	Northam	6401	Australia	6/06/2022
Hayley Hughes	Perth	6000	Australia	6/06/2022
Dana Houzeife	Sydney	2000	Australia	6/06/2022
Joshua Reichert	Northam	6401	Australia	7/06/2022
Emily O'DONNELL	Northam	6000	Australia	7/06/2022
Kira ashworth	Perth	6000	Australia	7/06/2022
Michael Palumbo	York	6302	Australia	7/06/2022
Dempsey quartermaine	Northam	6401	Australia	7/06/2022
Karen ODriscoll	Perth	6000	Australia	7/06/2022

Heather Meiklem	Northam	6403	Australia	7/06/2022
Margi M	Northam	6401	Australia	7/06/2022
Liam Mayo	Northam	6401	Australia	7/06/2022
Alanah Maddeford	Bakers hill	6562	Australia	7/06/2022
Andrea Church	Northam	6401	Australia	7/06/2022
Emma Chivell-O'Lynn	Victoria	3197	Australia	7/06/2022
Megan Glenie	Northam	6401	Australia	7/06/2022
Sheryl Thompson	Perth	6000	Australia	7/06/2022
Vesna AVRAMOSKI	Sydney	2001	Australia	7/06/2022
Jade Burgess	Perth	6000	Australia	7/06/2022
Chantal Hughes	Perth	6403	Australia	7/06/2022
Jessica Ducat	Perth	6000	Australia	7/06/2022
Chloe Bailey	Geraldton	6530	Australia	7/06/2022
Marilyn Hecker	Northam	6401	Australia	7/06/2022
Rowena Nunn			Australia	7/06/2022
Michaela Sandrini	Perth	6001	Australia	7/06/2022
Jordan Davis	Northam	6401	Australia	7/06/2022
Nicky Wille	Perth	6000	Australia	7/06/2022
Annette Gorman	Northam	6401	Australia	7/06/2022
Carolyn Carver			Australia	7/06/2022
Mckayla Young	Perth	6000	Australia	7/06/2022
Phoebe McGuinness	Broome	6725	Australia	7/06/2022
Rebecca Robles	Northam	6401	Australia	7/06/2022
Lorraine Kimberley	Northam	6401	Australia	7/06/2022
Kylie Howard	Perth	6401	Australia	7/06/2022
Rhys K	Perth	6000	Australia	7/06/2022
Paula Pisani	Perth	6000	Australia	7/06/2022
Luke Bidstrup	Perth	6000	Australia	7/06/2022
Josh Cording	Perth	6000	Australia	8/06/2022
Kirra ten Hove-Smith	Perth	6004	Australia	8/06/2022
Adrian Hardy	Perth	6000	Australia	8/06/2022
Aya Danin	Northam	6401	Australia	8/06/2022
Elisha Mayers	Forrestfield	6058	Australia	8/06/2022

Roni Sewell	YORK	6302	Australia	8/06/2022
Beryl Harmer	Western Australia	6490	Australia	8/06/2022
Kai Ashton	Northam	6401	Australia	8/06/2022
Tina Roser	Northam	6401	Australia	8/06/2022
Helen Miller	Northam	6401	Australia	8/06/2022
David Burgin	York	6302	Australia	8/06/2022
Amelia Howell	Melbourne	3338	Australia	8/06/2022
Jenny Josephs	YORK	6302	Australia	8/06/2022
Tamara Miller	Perth	6000	Australia	8/06/2022
Evie O'Brien	Bakers Hill	6562	Australia	8/06/2022
Sandy Boorman	Perth	6147	Australia	8/06/2022
Wesley Sutton	Toodyay	6566	Australia	8/06/2022
Rebecca Fowles	Perth	6000	Australia	8/06/2022
Theresa Tunna	Perth	6166	Australia	8/06/2022
Reny Luisa	Perth	6000	Australia	8/06/2022
Lauren O'Neil		6000	Australia	8/06/2022
Carol Head	Bakers Hill	6562	Australia	8/06/2022
Boorman Sally	Perth	6000	Australia	8/06/2022
Dannielle Cara			Australia	8/06/2022
Annette Hazlewood	Northam	6014	Australia	8/06/2022
Rebecca Hameister	Perth	6000	Australia	8/06/2022
Emily Burrow	Perth	6401	Australia	8/06/2022
Sandra Parry	West Toodyay	6566	Australia	8/06/2022
Justin Saine			Australia	8/06/2022
Kylie Chambers	Northam	6401	Australia	8/06/2022
Lee-Ellen Edmonds		6302	Australia	8/06/2022
Emma Louise	Northam	6401	Australia	8/06/2022
Alysia Holt	Perth	6000	Australia	9/06/2022
Louisa Langford	Perth	6000	Australia	9/06/2022
Kirra Cole		6401	Australia	9/06/2022
Tayla Barnett	Northam	6401	Australia	9/06/2022
Zabrina Dick		6401	Australia	9/06/2022
Julie Letton			Australia	9/06/2022

Ryan Guilfoyle	Perth	6000	Australia	9/06/2022
Krystle Burgess	Northam	6401	Australia	9/06/2022
Jayde Cleasby	Northam	6302	Australia	9/06/2022
Emma Elliott	Meckering	6405	Australia	9/06/2022
Tracy Thomassen	Melbourne	3029	Australia	9/06/2022
Roz Taylor		6054	Australia	9/06/2022
ve i	Sydney	2000	Australia	9/06/2022
Aliyah Abifares	Brisbane	4000	Australia	9/06/2022
Melissa Smith		6106	Australia	9/06/2022
Sonya Lee Lindner	Perth	6000	Australia	10/06/2022
Shagun Sharma		2131	Australia	10/06/2022
Leo :D	Brisbane	4000	Australia	10/06/2022
Gale Webster	Scarborough	6019	Australia	10/06/2022
Tess Bonanni	Brisbane	4000	Australia	10/06/2022
Mansour Gholami	Sydney	2000	Australia	10/06/2022
Darrell Foote	Adelaide	5033	Australia	11/06/2022
Andrea Baker	Northam	6401	Australia	11/06/2022
Alana Weatherly	Northam	6401	Australia	11/06/2022
Nicole Gibson	Northam	6401	Australia	11/06/2022
Alison McNamara		4211	Australia	11/06/2022
Sarah Allum	Perth	6000	Australia	11/06/2022
Michelle Garwood	Perth	6000	Australia	11/06/2022
Peta Wheatley	Gympie	4570	Australia	11/06/2022
Wayne Darley	Northam	6401	Australia	11/06/2022
Cherie Harvey	Perth	6000	Australia	11/06/2022
Kathrynne Grundy	Perth	6372	Australia	11/06/2022
Maddison Clark-Philbey	Northam	6401	Australia	11/06/2022
Jack Pollock	Northam	6401	Australia	12/06/2022
Amelia James	Sydney	2000	Australia	12/06/2022
Saloam Frazer	Ellenbrook	6069	Australia	13/06/2022
David Bradley	Northam	6401	Australia	13/06/2022
Deb Bewley	Townsville	4815	Australia	13/06/2022
Mike Oxchlong	Sydney	2000	Australia	14/06/2022

Lynne Clarke	Dowerin	6461	Australia	14/06/2022
Casey Garlett	Northam	6401	Australia	20/06/2022
Natalie Garlett	Perth	6000	Australia	20/06/2022
Melinda Thorn	Perth	6056	Australia	21/06/2022
Heath Croker			Australia	21/06/2022
Victoria Davis	Northam	6401	Australia	24/06/2022
Emma Hazelden	Perth	6000	Australia	24/06/2022
Dee O'Driscoll	Northam	6401	Australia	25/06/2022
George Elenikovskii	Wollongong	2500	Australia	25/06/2022
Simon. Fiveash		4178	Australia	25/06/2022
Daphne Lobo	Chatswood	2067	Australia	25/06/2022
Fiona Cossart	Toodyay	6566	Australia	29/06/2022
Sherree W	Northam	6401	Australia	29/06/2022
Ratna Knights	Northam	6401	Australia	29/06/2022
Brittany Saulys	Perth	6401	Australia	29/06/2022
Terry Larkin	Northam	6000	Australia	29/06/2022
Peter Larkin	Northam	6000	Australia	29/06/2022
Jan McDonagh	Perth	6000	Australia	30/06/2022
Sharon Mann	Deanmill	6255	Australia	30/06/2022
Amanda Fleming	Perth	6060	Australia	30/06/2022
Amy Zwetsloot	Northam	6401	Australia	1/07/2022
Elisabeth Bechmann	Polten	3100	Austria	7/06/2022
Bambi Mayr			Austria	9/06/2022
Cuisenaire Martine	Heer	5543	Belgium	7/06/2022
Sylvia DRIOULE	Liège		Belgium	8/06/2022
Marc Huysmans	Edegem		Belgium	8/06/2022
Alain Neven	Seraing		Belgium	8/06/2022
simone maes		9000	Belgium	8/06/2022
Andréa Branco	Sao Paulo	4110	Brazil	8/06/2022
Doris Matte	Porto Alegre	90000	Brazil	8/06/2022
Renata Cheferrino	Rio de Janeiro	22785-200	Brazil	9/06/2022
Gerard Goulette	Montréal	H1e3e9	Canada	7/06/2022
Joyce Brown	longueuil	j4l 1r8	Canada	7/06/2022



Mike Andrews	Hamilton	L8N1M2	Canada	8/06/2022
sylvie auger	Trois-Rivières	G8Y 6S9	Canada	8/06/2022
Luc Beaulieu	Montréal	H3G	Canada	8/06/2022
Cindy Janzen	Niagara Falls	L2G	Canada	11/06/2022
Kristina Sedic	Zagreb	10000	Croatia	8/06/2022
Niina Anttinen	Espoo		Finland	7/06/2022
Nina Lättilä	Rajamäki		Finland	8/06/2022
Ulbrich Christiane	Moyeuivre-grande	57250	France	7/06/2022
Caroline Sévilla	Paris	75001	France	7/06/2022
Veronique Dick		57700	France	7/06/2022
cathala corine	Pierrelatte	26700	France	7/06/2022
jade ALF	Blois	41000	France	7/06/2022
Frédéric Jaubert	Pont de Chéruy	38230	France	7/06/2022
Raphaël PONCE	TOULOUSE	31140	France	7/06/2022
Djamila grouci	Paris	75011	France	7/06/2022
Dominique LANG	Vaison-la-Romaine	84110	France	7/06/2022
Chantal Thomas	Frejus	83600	France	8/06/2022
alan henry	Tours	37100	France	8/06/2022
Nelly PRESTAT	Mouroux	77120	France	8/06/2022
vie.espoir	La Suze	72210	France	8/06/2022
Francine Sandras	Annoeullin	59112	France	8/06/2022
Shayna Tyler	Vallentigny	10500	France	8/06/2022
Sabine Möhler	Esselbach	97839	Germany	7/06/2022
Petra Achtzehnter	Kaiserslautern	67663	Germany	7/06/2022
Marion Piepenbrink	Dusseldorf	40472	Germany	7/06/2022
Anne Montarou	Ahrensburg	22926	Germany	7/06/2022
A. Otto	Auerbach	8209	Germany	7/06/2022
Petra Hegenscheidt	Essen		Germany	7/06/2022
christa lohrig	Petersberg	41352	Germany	7/06/2022
Uwe Vietzke			Germany	7/06/2022
Claudia Neuhalfen	Bonn	53117	Germany	7/06/2022
Rosi Zang	Aschaffenburg	63743	Germany	7/06/2022
marion jurchen	Berlin	13409	Germany	7/06/2022

holger meyer	Weyhe	28844	Germany	7/06/2022
Ana Gruber	Wolfratshausen	82515	Germany	7/06/2022
R S	Koln	51069	Germany	7/06/2022
Ellen Gurtner	Mönchengladbach	41189	Germany	7/06/2022
Nadine Baldi	Karlsdorf-Neuthard	76709	Germany	8/06/2022
Janina Grage		44649	Germany	8/06/2022
Theresia Maria	Deutschland	66957	Germany	8/06/2022
Jasmin Porschen	München		Germany	8/06/2022
Karin Zimmermann	Hersbruck	91217	Germany	13/06/2022
Brian McCabe			Ireland	6/06/2022
Graham Duncan	Dublin	D02	Ireland	8/06/2022
Consuelo Serena Velasco	Strambino Fr Cerone	10019	Italy	8/06/2022
Tiziana Dordoni	Corsico milano	20094	Italy	9/06/2022
Christna Frutuoso	Esch	4069	Luxembourg	7/06/2022
hortencia mendoza		44260	Mexico	7/06/2022
Maria Van Geel	Hoogerheide	4631 TB	Netherlands	7/06/2022
Anneke Andries	Raamsdonksveer	4941JT	Netherlands	7/06/2022
Mirjam Talma	Buitenpost	9285VZ	Netherlands	7/06/2022
Astrid V.d. Geest	Stadskanaal	9502	Netherlands	7/06/2022
Koeno van der Schuur	Apeldoorn	7203	Netherlands	8/06/2022
marlie scholten	Daarlerveen	7687	Netherlands	8/06/2022
Andre Ferro	Helmond	5707RN	Netherlands	9/06/2022
Chantal Martin	Koné	98807	New Caledonia	8/06/2022
L Saunders	Masterton		New Zealand	7/06/2022
THERESE ANN DURANO	Manila		Philippines	9/06/2022
Robert Nowak			Poland	7/06/2022
Oleg Kobets	Kemerovo	650001	Russia	7/06/2022
rolf wiesler	Johannesburg	2041	South Africa	12/06/2022
Susana Muñoz	Madrid	28019	Spain	30/05/2022
Rosa Cabrerizo	L'Hospitalet de Llobregat	8906	Spain	8/06/2022
catherine cheneval	LYON	73000	Spain	8/06/2022
Christine Thörnwall	Norrköping	602 22	Sweden	8/06/2022
Jacqueline Lavanchy	Martigny	1920	Switzerland	7/06/2022

Eva Maria Genovese	MuttENZ		Switzerland	12/06/2022
Sue Cone	Hull	HU13 9DS	UK	7/06/2022
Joyce Alexander	Edinburgh	EH11	UK	7/06/2022
Julie Port	Slough	SL1	UK	7/06/2022
Andrew Vallender	Ventnor	PO38 1BH	UK	8/06/2022
Bruce Forster	Gateshead	NE9	UK	8/06/2022
Alexandra Scott	Newcastle-u-Lyme	ST5 8BE	UK	9/06/2022
dave cotterell	Birmingham	b280uw	UK	15/06/2022
yolanda schultes	Wittenbach	9300	US	7/06/2022
Robbie Hacha	New York	10009	US	7/06/2022
Kate Kenner	Guilford	5301	US	7/06/2022
sara sang	los angeles	91601	US	7/06/2022
sarika arora	Alpharetta	30022	US	7/06/2022
jocelyne lapointe	Terrebonne	j6w0b5	US	7/06/2022
Maryann Staron	Hometown	60456-1035	US	7/06/2022
Christeen Anderson	Crestview	32539	US	7/06/2022
Carmen Guillemette	Palatine	60074	US	8/06/2022
Tabitha Totten	Cliffside Park	07010-1721	US	8/06/2022
Pam Miller	Tolar	76046	US	8/06/2022
SHIRLEY AUSTIN	London	E6 2EX	US	9/06/2022
Janis Millu	Franklin	16323	US	9/06/2022
Greg Ratkovsky	Oakland	94619	US	9/06/2022
Lisa Salazar	Shasta Lake	96089	US	10/06/2022
Nancy Petersen	Claremont	91711	US	15/06/2022

### SHIRE OF NORTHAM

### DOG LOVERS PETITION FOR A FENCED DOG PARK

Please sign your name below with your address and mobile contact numbers to petition the Shire for a fenced dog park.

Optimally a fully fenced, off leash dog park large enough for small dog and large dog designated areas.

The goal is to avoid unwanted dog and human, and dog and dog interactions, increase opportunities for residents to mingle and can be used to promote responsible dog ownership.

The petition asks for two separate areas to accommodate small and big dogs in addition to adequate shade, water points, seating, public amenities notified of closest available, and suitable parking.

NAME	ADDRESS	MOBILE	SIGNATURE
Toni Hotker	4 Rainford Way	0439211211	[Signature]
Kaelle O'Brien	Northam	0417137149	[Signature]
Bomb Sager	GP	0439834019	[Signature]
Rose Nanger	NORTHAM	9622228	[Signature]
Suzanne Roper	Jame st, Northam	0429111880	[Signature]
Marilyn de Beaux	19 Lockyer Ave, Northam	0497689080	[Signature]
MIKH TOCK	402 FRENCHES RD	0456614123	[Signature]
JOHN HAYTON	30 OLD YORK RD	040612002	[Signature]
TONY HUMPHREY	30 OLD YORK RD	0417905506	[Signature]
LUCY HUMPHREY	30 OLD YORK RD	045074570	[Signature]
Ryneth Hayes	21 Old York Rd,	0406255864	[Signature]
J + G.	NORTHAM	0407995091	[Signature]
K Tatham	NORTHAM	0439370164	[Signature]
M. NEWEN DARR	WORK NORTHAM	0401149603	[Signature]
Jade Richards	Northam	044983472	[Signature]
MATT STORCEVICH	WINDGOLIE	0419961178	[Signature]
Jacob Ferguson	Northam	0491182815	[Signature]
WATTS	W. JARVIS		[Signature]
Georgia Stanley	17 Battery Street	0479166062	[Signature]

**16. URGENT BUSINESS APPROVED BY DECISION**

Nil.

**17. DECLARATION OF CLOSURE**

There being no further business, the Shire President, Cr C R Antonio declared the meeting closed at 6:18pm.

"I certify that the Minutes of the Ordinary Meeting of Council held on Wednesday, 17 August 2022 have been confirmed as a true and correct record."



\_\_\_\_\_  
President

21/9/2022

\_\_\_\_\_  
Date